

## Vehicular Swing Gate Operator

**Nice**  
Gate Operators

**Titan**  
**912L**



*The Titan 912L Gate Operator is intended for use with vehicular swing gates. The Titan 912L Gate Operator can be used in Class I, Class II and Class III applications.*

# TABLE OF CONTENTS

---

<b>CAUTIONS AND NOTES</b>	1	<b>6 - ACCESSORY INPUTS AND OUTPUTS</b>	12
<b>EXTREMELY IMPORTANT</b>	1	6.1 - Outputs	12
<b>ETL DEFINITIONS COMPLIANT TO UL325</b>	1	6.2 - Inputs	12
		6.3 - Communication busses	13
<b>1- OVERVIEW</b>	1	<b>7 - 120VAC POWER WIRING</b>	14
1.1 - 936 Control board	1	<b>8 - SOLAR PANEL CHART</b>	14
1.2 - Main control board specifics	1	<b>9 - OPTIONAL INPUTS</b>	15
<b>2 - GATE INFORMATION</b>	1	9.1 - Fire department connection	15
2.1 - ASTM F2200	1	9.2 - Magnetic lock connection	15
2.2 - Gate latches	2	9.3 - Guard station	15
2.3 - Specific applications	2	9.4 - Exit and edge inputs wiring diagram	15
2.4 - Swing gates	2	<b>10 - RADIO RECEIVER CONNECTION (THIRD PARTY)</b>	16
2.5 - General requirements	2	<b>11 - INSPECTION AND OPERATION</b>	16
<b>3 - SAFETY AND CAUTIONS</b>	2	<b>12 - GENERAL LAYOUT AND SAFETY ACCESS</b>	17
3.1 - Properly installed safety devices	2	<b>13 - ACCESSORIES AND SENSORS</b>	18
3.2 - Safety signs, notices to personnel warning signs	2	<b>14 - MANUAL RELEASE/MANUAL OPERATION</b>	19
3.3 - Gate system safety devices	3	<b>15 - 1050 PROGRAMMING</b>	20
3.4 - Infrared beams and warning signs	3	15.1 - Force	20
3.5 - Establish the location	3	15.2 - Speed	20
3.6 - Read and follow all instructions	3	15.3 - Acceleration	20
3.7 - Keep children away	3	15.4 - Delay	20
3.8 - Test the gate system	3	15.5 - Function	20
3.9 - Keep gates properly maintained	3	15.6 - Display	21
<b>4 - PRE-INSTALLATION NOTES</b>	3	<b>16 - EMERGENCY VEHICLE ACCESS</b>	22
4.1 - Follow instructions	3	<b>17 - GLOSSARY</b>	22
4.2 - Intended usage	3		
4.3 - Warnings, cautions and notes	3		
<b>5 - INSTALLATION PROCEDURES</b>	5		
5.1 - Pivot arm installation	5		
5.2 - Push to open installation	6		
5.3 - Actuator mounting	6		
5.4 - Control box mounting	7		
5.5 - Incoming power wiring	7		
5.6 - Titan actuator wiring	8		
5.7 - Limit and Motor connections to the board	9		
5.8 - Limit switch adjustment	10		
5.9 - 1050 controller learning procedure	11		

# LIST OF FIGURES

---

<b>Figure 5-1</b> Left And Right Hand Swing Pivot Point	5
<b>Figure 5-2</b> Vertical Pivot Position	5
<b>Figure 5-3</b> Pivot Arm Installation	6
<b>Figure 5-4</b> Hinge Post	6
<b>Figure 5-5</b> Actuator Mounting	6
<b>Figure 5-6</b> Control Box Mounting	7
<b>Figure 5- 7</b> Incoming Power Wiring	7
<b>Figure 5-8</b> Manual Release Handle	8
<b>Figure 5-9</b> Titan Actuator Wiring	8
<b>Figure 5-10</b> Titan Actuator Wiring	8
<b>Figure 5-11</b> Titan Actuator Wiring (Standard)	8
<b>Figure 5-12</b> Titan Actuator Wiring (Push To Open)	8
<b>Figure 5-13</b> Actuator Motor Leads	9
<b>Figure 5-14</b> Actuator Motor Leads	9
<b>Figure 5-15</b> Limit And Motor Connection To The Board	9
<b>Figure 5-16</b> Gate Bracket Mounting	10
<b>Figure 5-17</b> Limit Switch Adjustment	10
<b>Figure 5-19</b> Learning Mode - Open Limit	10
<b>Figure 5-20</b> Learning Mode - Closed Limit	10
<b>Figure 6-1</b> Board Outputs	12
<b>Figure 6-2</b> Board Inputs	12
<b>Figure 6-3</b> Communication Buses	13
<b>Figure 7-1</b> Equipment Safety Warnings	14
<b>Figure 9-1</b> Fire Department Input	15
<b>Figure 9-2</b> Magnetic Lock Wiring (Example)	15
<b>Figure 9-3</b> Guard Station Inputs	15
<b>Figure 9-4</b> Exit And Edge Inputs	15
<b>Figure 10-1</b> Radio Receiver	16
<b>Figure 12-1</b> Layout For Inground Loops	17
<b>Figure 12-2</b> Layout For Photocells	17
<b>Figure 14 -1</b> Manual Release	19
<b>Figure 13-3</b> Manual Release Disable	19

## CAUTIONS AND NOTES

This instruction manual is intended to aid the installer in the overall process of correct installation at the desired location. Periodically, the manual will illustrate "warnings, cautions and notes" which are items the installer should carefully read to prevent damage to the gate, gate system or personal injury to yourself or others.

### EXTREMELY IMPORTANT

Anyone who installs, assists with installation or otherwise facilitates the installation in any manner should thoroughly read and understand this manual in its entirety before any attempt is made to actually begin the installation process.

### ETL DEFINITIONS COMPLIANT TO UL325

- Vehicular Swing-Gate Operator (or system) - A vehicular gate operator (or system) that controls a gate which swings or rotates in a direction that is intended for use for vehicular entrance or exit to a drive, parking lot, or the like.
- Gate - A moving barrier such as a Swinging, sliding, raising, lowering, rolling, or like barrier that is a stand-alone passage barrier or is that portion of a wall or fence system that controls entrance and/or egress by persons or vehicles and completes the perimeter of a defined area.
- Residential Vehicular Gate Operator - Class I - A vehicular gate operator (or system) intended for use in a home of one to four single family dwellings, or a garage or parking area associated therewith.
- Commercial / General Access Vehicular Gate Operator - Class II - A vehicular gate operator (or system) intended for use in a commercial location or building such as a multi-family housing unit (five or more single family units), hotel, garages, retail store, or other buildings servicing the general public.
- Commercial / General Access Vehicular Gate Operator - Class III - A vehicular gate operator (or system) intended for use in an industrial location, loading dock area, or other location not intended to service the general public.

## 1 - OVERVIEW

This manual provides documentation for mechanical installation and electrical wiring of the Titan swing gate opener with the Nice-brand 1050 gate operator. The Titan swing gate opener is intended for residential gate installations only. Please consult your Nice distributor or Nice dealer/installer for more information regarding installations or questions not specifically covered in this manual.



**DO NOT CONNECT  
A/C POWER TO THIS  
CIRCUIT BOARD!**

This circuit board is designed for  
10VDC - 35VDC power input only.

## 1.1 - Titan Swing Gate Opener

The Titan 912L swing gate operator delivers the next generation of easily installed, configured and maintained swing gate operators from Nice. With a maximum gate capacity of 600 lbs and 20 ft, this operator has a key lockable manual release, easily accessible limit switch settings as well as simple in-the-field maintenance and repair. The Titan gives dealers, installers and homeowners the ability to take control of their access and security systems. Combining the Titan with Nice brand control boards like the 1050 will bring solid performance for hundreds of thousands of open and close cycles. This operator includes a 2-year factory warranty against manufacturing defects and lifetime customer support.

## 1.2 - Titan Swing Gate Opener Specifications

<b>Operator Specifications</b>	<b>912L (+12VDC)</b>
Maximum Swing Gate Length	20ft.
Maximum Swing Gate Weight	600lbs.
Solar Compatible	Yes
Manual Release with Key-lock	Yes
Motor Encoder	Yes
Maximum Degree of Opening	120°
Easily Positioned Limit Switches	Yes
Drive Mechanism	Stainless Steel Screw
Operating Temperature	-4°F to 122°F
Weight	19.75lbs.
Dimensions - Fully Retracted	43"(L) x 4"(W) x 6.75"(D)
Push to Open Installation	Yes
Pull to Open Installation	Yes
UL 325 Certified/Listed	Yes

## 2 - GATE INFORMATION

### 2.1 - ASTM F2200

Gates shall be constructed in accordance with the provisions given for the appropriate gate type listed, refer to ASTM F2200 for additional gate types. Protrusions shall not be permitted on any gate, refer to ASTM F2200 for exceptions, if any.

Any non-automated gate that is to be automated in any manner should be upgraded to conform to the provisions contained within the provisions of this document and ASTM F2200 as applicable.

## 2.2 - Gate latches

In association with this gate controller and these swing gate operators, at no time should manual gate latches or locks be used. The forces applied to a swing gate operator could be in excess of those forces which are safe for bystanders. Should unnecessary forces be applied to a gate system which is in the locked position, the catastrophic failure of the gate or locking mechanism could result in substantial damage, extensive physical injury and or death.

## 2.3 - Specific applications

This swing gate operators are intended for those locations where vehicle traffic is intended to be controlled through the use of an entryway obstruction (gate). The gate system should be made of closed material types which prevent any body part from entering, becoming entangled or otherwise entering the gate in any manner. If the gate is not fully closed off from access, the opening or closing of the gate system may result in severe damage, injury or death.

## 2.4 - Swing and slide gates

Swing and slide gates are designed to move across an entry control point to prevent or allow controlled access by authorized persons or equipment. Swing or slide gate systems are not necessarily completely autonomous systems, and require regular maintenance and inspection on a periodic schedule. Although with certain safety devices in place the gate system could operate as a completely independent system free from human interaction for a defined period of time, human inspection and testing is required to ensure longevity and safe operation over long periods of time.

## 2.5 - General requirements

- Safety and security are obviously a number one priority for both the manufacturer and the end user. As a result this manual has been written to make all persons fully aware of the responsibilities required to ensure constant safety, security and longevity are acquired throughout the life of the system.
- The manufacturer of this swing gate system has performed countless hours of testing, analysis and statistical control analysis to ensure that this operator performs its intended function for extended periods of time. The installer should ensure and verify that all required safety devices are installed correctly and in a manner consistent with the requirements of this manual. Additionally, all devices, security devices, safety devices, sensors and other affiliated attachments are installed in a robust manner that will prevent their accidental damage, removal or incidental tampering.
- A basic requirement for this system to operate correctly is that at any time a sensor is triggered, covered, disconnected or otherwise tampered with, that the entire system ceases to function. If any part of the gate safety system is removed or triggered, an immediate safety action by the gate operator is expected (retraction or stoppage). If the gate safety system is not functional, or fails to operate within these guidelines, the gate should be immediately removed from service until repairs can be made.
- Any gate system that is open or has slats, bars or other material which allows an individual to stick their hands, head, or feet through the material, must be converted or covered in such a manner so as to prevent such future actions. Application of materials, and how to modify the gate system is up to the end user or installer, however care should be taken to prevent such human interaction into the moving gate system. No entry into the gate is ever authorized and should be prevented by whatever measures are required for that specific installation. Care should always be used during installation!
- Loops and loop detectors, photo-cells or other equivalent devices must be installed with this gate operator to prevent the gate from closing on vehicular traffic
- The speed limit for vehicular traffic through the gate area is 5 MPH. Install speed bumps and signs to keep vehicular traffic from speeding through the gate area. Failure to adhere to posted speed limits can result in damage to the gate, gate operator, and to the vehicle.
- Be sure that all residents are familiar with the proper use of the gate and gate operator. Be sure that all residents are familiar with the possible hazards associated with the gate system.
- Be sure that all warning signs are permanently installed on both sides of the gate in an area where they are fully visible to traffic
- It is your responsibility to periodically check all reversing devices. If any of these devices are observed to function improperly, remove the operator from service immediately and contact your installing or servicing dealer.

- Follow the recommended maintenance schedule of one inspection per every 180 days of use.
- Do not allow children to play in the area of the operator or to play with any gate-operating device.
- Be sure that all activating devices are installed a minimum distance of 8 feet away from the gate and gate operator, or in such a way that a person cannot touch the gate or gate operator while using the activating device. If activating devices are installed in violation of these restrictions, immediately remove the gate operator from service and contact your installing dealer.
- To remove the gate operator from service, operate the gate to the full open position, shut off power to the operator at the service panel, and disconnect batteries.



### **AUTOMATIC GATES ARE NOT FOR PEDESTRIANS!**



Automatic gate openers are designed for vehicular traffic. They are powerful and can cause serious bodily injury or death. Accordingly, direct all pedestrian traffic to a separate walk-through gate.

## 3 - SAFETY AND CAUTIONS



### **WARNING**

#### **IMPORTANT SAFETY INSTRUCTIONS**

#### **WARNING - TO REDUCE THE RISK OF INJURY OR DEATH READ AND FOLLOW ALL INSTRUCTIONS.**

- Never let children operate or play with gate controls. Keep the remote control away from children.
- Always keep people and objects away from gate. **NO ONE SHOULD CROSS THE PATH OF THE MOVING GATE.**
- Test the operator periodically. The gate **MUST** reverse on contact with a rigid object or stop or reverse when an object activates the non-contact sensors. After adjusting the force or the limit of travel, retest the gate operator. Failure to adjust and retest the gate operator properly can increase the risk of injury or death.
- Use the emergency release only when the gate is not moving.
- **KEEP GATES PROPERLY MAINTAINED.** Read the owner's manual. Have a qualified service person make repairs to gate hardware.
- The entrance is for vehicles only. Pedestrians must use separate entrance.
- **SAVE THESE INSTRUCTIONS!**

### **3.1 - Properly installed safety devices**

Safety devices are used to sense, register and prevent damage to vehicular traffic which may block the path of the gate system. If properly installed and inspected for functionality within the prescribed maintenance procedures, the safety devices should prevent the gate system from inflicting harm or damage as a result of its opening and closing action.

### **3.2 - Safety signs, notices to personnel warning signs**

Safety devices must alert all who may enter the gate system area, as to the danger posed by moving equipment. Safety features must be installed and work correctly, such as the infrared beam. This safety device prevents serious injury or death as a result of the gate closing while an object or person blocks the gate operating pathway. An optional flashing lamp that is activated anytime the gate is moving should be added in addition to the aforementioned safety features.

### 3.3 - Gate system safety devices

Automatic gate operators are designed to move a heavy steel gate. Great amounts of force are sometimes used to move these heavy systems. The automatic gate system may cause significant damage or injury if the path of the gate is obstructed. All sensors, safety devices and warning notices must be in place and operable in order for this system to operate properly. It is the installer's responsibility to install this system properly and to ensure its correct and safe operation.

### 3.4 - Infrared beams and warning signs

Infrared beams are used to inform the control board that an obstruction is present. Safety devices must be installed properly and inspected periodically to ensure continued reliability and safety. Safety devices, safety sensors, warning signs and notices of moving equipment danger must be installed and readily visible by all paths of approach to the gate system. Failure to post warnings could result in loss of life, damage or physical injury.

### 3.5 - Establish the location

The installer of this system needs to establish the location of the opener in accordance with instructions contained within this manual. A typical layout is provided at the end of this manual with a nominal basic drawing. It is the installer's responsibility to ensure that the opener is installed in such a fashion so as to prevent binding, pinching or improper articulation of the system throughout its actuation cycle.

### 3.6 - Read and follow all instructions

### 3.7 - Keep children away

Never let children operate or play with gate controls. Keep the remote control away from children.

### 3.8 - Test the gate system

The gate must reverse on contact with a rigid object or stop when an object activates the non-contact sensors. After adjusting the force or the limit of travel, retest the gate operator. Failure to adjust and retest the gate operator properly can increase the risk of injury or death. Test force and correct functionality for photo-eyes and other safety devices at least every 6 months. ONLY USE the MANUAL RELEASE when the gate is not moving or when the unit fails or in case of power outage.

- Turn the power to the gate controller OFF AND REMOVE BATTERIES before using the emergency release.

### 3.9 - Keep gates properly maintained

Have only a qualified service person make repairs. Unqualified service technicians are not recommended.

## 4 - PRE-INSTALLATION NOTES

Before installing and/or operating the gate opener, installers and/or users should do the following:

- Confirm the gate operator being installed is appropriate for the application.
- Confirm the gate is designed and built according to current applicable published industry standards.
- Confirm all appropriate features and accessory devices are being incorporated, including both primary and secondary entrapment protection devices.
- Make sure the gate works freely before installing the operator.
- Repair or service worn or damaged gate hardware before installing the operator.
- Adjust the FORCE device to the minimum force setting that allows reliable gate operation.
- Install operator inside fence line (DO NOT install operator on public side of fence line).
- Swinging gates shall not open into public access areas.
- Install a proper electrical ground to a gate operator.
- Install keypad controls where users cannot touch, or reach through gate while operating controls, which is a minimum of 8 feet from the gate.
- Install controls where user has full view of gate operation.
- Install all warning signs (In accordance with UL 325) on both sides of the gate to warn persons in the area of potential hazards associated with automatic vehicular gate operation.

- A minimum of two (2) WARNING SIGNS shall be installed, one on each side of the gate where easily visible.
- Test all features for proper functions before placing the automatic vehicular gate opener into service.
- Demonstrate the basic functions and safety features of the gate system to owners/end users/general contractors, including how to turn off power and how to operate the manual release feature.
- Leave safety instructions, product literature, installation manual and maintenance instructions with end user.
- Explain to the owners/users the importance of a service contract that includes a routine testing of the entire system including the entrapment protection devices, and explain the need for the owners to insure that this testing is performed routinely.
- Offer the owner/end user a maintenance contract, or contact them regularly to offer maintenance.
- See instructions on the placement of non-contact sensors for each type of application.

### 4.1 - Follow Instructions

Always follow all instructions included in this manual to ensure safety and the longevity of the operator.

### 4.2 - Intended usage

THIS CIRCUIT BOARD IS INTENDED FOR USE WITH VEHICULAR SWING AND SLIDE GATES ONLY.

### 4.3 - Warnings, cautions and notes

- 4.3.1 Gate terms "system", "gate operator", "gate system", and "gate operator system" for these warnings, cautions, and notes is intended to cover the gate controller, gate controller software, the gate actuator, and all safety accessories included within a typical installation.
- 4.3.2 Gate system designers, installers and users must take into consideration the inherent hazards associated with each installation, since no two installations will be exactly alike.
- 4.3.3 Improperly designed, constructed, installed or maintained systems can and may introduce hazards which may or may not be readily seen or identified by users, bystanders, installers or inspectors
- 4.3.3 Improperly designed, constructed, installed or maintained systems can and may introduce hazards which may or may not be readily seen or identified by users, bystanders, installers or inspectors
- 4.3.4 All pinch points must be guarded or eliminated.
- 4.3.5 Only install this gate system opener in appropriate manners in which the operation is safe and secure.
- 4.3.6 A gate operator exerts a great amount of force in order to move the gate system in normal operation, therefore appropriate safety sensors, measures, notices and appropriate safety features must be incorporated in all installations.
- 4.3.7 The gate must be installed correctly and no binding or resistance should be present throughout its movement in either direction.
- 4.3.8 The gate system must be installed in an area and in such a manner in which the gate has sufficient clearance to open, close and move without striking or contacting any structures and/or other obstructions.
- 4.3.9 The gate system is designed for vehicular traffic only, and should never, under any situation be used for pedestrian traffic
- 4.3.10 Pedestrian prohibited signs, warning signs or other suitable measures must be used at minimum, to warn pedestrians to stay away from, and to not use this system under any circumstances.
- 4.3.11 Pedestrians should be encouraged to use a pedestrian entry/exit only.
- 4.3.12 Pedestrians should never cross the path of a moving gate. The sensors are designed to prevent contact with a vehicle and are not necessarily capable of preventing contact with a pedestrian. Care should be taken to prevent pedestrian usage under any circumstances.
- 4.3.13 One or more non-contact sensors must be used in any situation or area where entrapment may have the possibility of occurring.
- 4.3.14 Gates shall be constructed in accordance with the provisions given for the appropriate gate type listed, refer to ASTM F2200 for additional gate types.
- 4.3.15 Any existing manual gate latches shall be removed or disabled when an automatic gate system is installed. Use only mag-locks controlled

- 4.3.16 Protrusions shall not be permitted on any gate, refer to ASTM F2200 for exceptions, if any.
- 4.3.17 Gates shall not be designed, constructed and installed in such a manner that gravity will cause or initiate movement in any direction whether the operator is attached or not.
- 4.3.18 A pedestrian gate shall not, under any circumstances, be attached to, or incorporated into, any vehicular gate system in manner. This also applies to any fence or wall, or any portion thereof, that the gate may cover in the open or closed position.
- 4.3.19 Any non automated gate that is to be automated in any manner should be upgraded to conform to the provisions contained within the provisions of this document and ASTM F2200 as applicable.
- 4.3.20 To reduce the risk of severe injury or death please read and understand this entire manual and your local code requirements prior to starting installation. Additionally, understanding the ASTM standards will assist you in the proper assembly, installation and operation of your gate opening system.
- 4.3.21 Disconnect all electricity and/or all sources of power before performing any maintenance.
- 4.3.22 To reduce the risks of fire or injury always contact the installer or distributor prior to performing any repairs or maintenance.
- 4.3.23 Never operate gate with obstructions present.
- 4.3.24 No one should ever cross the operative path of the gate.
- 4.3.25 Never let children play or linger in the vicinity of the gate or opener equipment.
- 4.3.26 Never operate the gate or the opener when the opener is not operating or adjusted correctly.
- 4.3.27 Never allow children to play with or manipulate gate controls. Keep all remotes away from children.
- 4.3.28 Only use the MANUAL RELEASE when gate is completely stationary. Untrained persons should never touch the gate or any releases if any are installed or applicable.
- 4.3.29 Test the gate operator periodically (once every 6 months minimum). Gate must reverse course or stop immediately upon contact with any source in its path. Gate must stop and reverse course at any time any object or other item crosses the path of the gate. Should the safety sensors not stop and/or reverse the gates travel, immediately investigate and repair the inoperative condition. Gate should not be used under any circumstances, if all sensors and safety devices are not performing to standards illustrated within this manual.
- 4.3.30 Gate should not be used if safety devices are not performing to all local, state and federal guidelines.
- 4.3.31 Replace fuse only with fuse of same type and rating.
- 4.3.32 Installation of this gate system in a manner inconsistent with the manufacturer's recommended instructions, local, State or Federal law transfers the liability unto the installer. Careful consideration has been taken by the manufacturer's to devise safe measures, safe design and incorporate safety measures to prevent injury, death or property damage. By circumventing, ignoring or modifying any safety system or the exclusion thereof, the installer is creating a new untested process outside the purview of the manufacturer and therefore assumes all risk.
- 4.3.33 This unit is not to be installed on any gate, door or other structure which serves to block, secure, close off or otherwise control a pedestrian entry point or access point.
- 4.3.34 Vehicular swing gates shall be designed, constructed and installed in accordance with security related parameters specific to the application in question, with absolute safety in all considerations.
- 4.3.35 Never mount any device that operates the gate opener where the user can reach around, over or through the gate to operate the controls. Controls should be mounted at minimum, 8 feet away from any moving part of the gate or gate system.
- 4.3.36 A hard wired control shall be located in such a manner so that electronic communication between the two is never interrupted or the wires damaged.
- 4.3.37 Any controls used to reset the device after obstruction/entrapment protection incidents should be located within view of the gate and should have safety features that prevent unauthorized use.
- 4.3.38 Never allow anyone to ride, hang on or otherwise touch the gate.
- 4.3.39 Safety sensors must be present at all times. The hard wired safety sensors must be arranged and installed in such a manner so that the communication between gate operator and sensor(s) are never interrupted or severed by mechanical damage or movement. All items which have sensors or safety devices installed must be constructed or installed in such a manner so as to prevent removal or damage. All subsequent sensors must be suitable for the system installed and approved for use.
- 4.3.40 Never increase the force used to move the gate, beyond the absolute minimum required.
- 4.3.41 Never use force adjustments to compensate for binding, sticking or resistant operation. These situations should be addressed and corrected before installation of the gate operator. Gate systems should swing freely in all directions prior to installation of this gate operator.
- 4.3.42 After any adjustment is made, all safety modes/features must be tested. Gate must stop or reverse upon any object crossing the path of the gate or the gate comes into contact with any object.
- 4.3.43 Activate gate only when the gate is in clear view of the user, the gate system is properly adjusted, tested and verified, and there are no obstructions present.
- 4.3.44 Keep gate and gate system properly maintained and properly inspected at all times.
- 4.3.45 This operator is intended for installation only on swing and slide gates used to control vehicular traffic.
- 4.3.46 The gate must be installed in a location so that sufficient clearance is provided between the gate and adjacent structures when opening and closing to reduce the risk of entrapment.
- 4.3.47 The gate must be properly installed and work freely in both directions prior to the installation of the gate operator.
- 4.3.48 Install the gate operator only when the operator is appropriate for the construction and the usage class of the gate.
- 4.3.49 The gate must be properly installed and work freely in both directions prior to the installation of the gate operator.
- 4.3.50 Controls must be far enough from the gate so that the user is prevented from coming in contact with the gate while operating the controls. Controls intended to be used to reset an operator after two sequential activations of the entrapment protection device(s) must be located in the line of sight of the outdoor gate or easily accessible controls shall have a security feature to prevent unauthorized use.
- 4.3.51 All warning signs and placards must be installed where visible in the area of the gate.
- 4.3.52 Care shall be given to reduce the risk of nuisance tripping such as when a vehicle trips the sensor while the gate is still moving.
- 4.3.53 Gate operators must utilize a contact sensor such as an edge sensor.
- 4.3.54 A hardwired contact sensor shall be located and its wiring arranged so that the communication between the sensor and the gate operator is not subject to mechanical damage.
- 4.3.55 A wireless contact sensor such as one that transmits radio frequency (RF) signals to the gate operator for entrapment protection functions are recommended.

## 5 - INSTALLATION PROCEDURES

### 5.1 - Pivot Arm Installation

**IMPORTANT** - Never weld parts to the gate or posts when the operator circuit board is powered. Doing so may damage the board beyond repair.

#### **PULL TO OPEN INSTALLATION - PIVOT ARM INSTALLATION - Location of Pivot Point**

The following instructions provide up to 105° of swing.

Measurements are taken from the center of pivot of the gate hinge.

The pivot arm needs to be securely mounted to the hinge post or equivalent mounting surface. It is recommended to weld the pivot arm to a metal post. In order to achieve the correct articulation, geometry and rate of speed of the gate it is critical that the measurements below are followed. The pivot arm may need to be cut to achieve the correct placement of the actuator mounting hole. Measurements are taken from the center of pivot of the gate hinge.

#### **NOTE**

If you have columns built around your gate hinge post, check these measurements for proper clearance before proceeding with this pull to open installation.

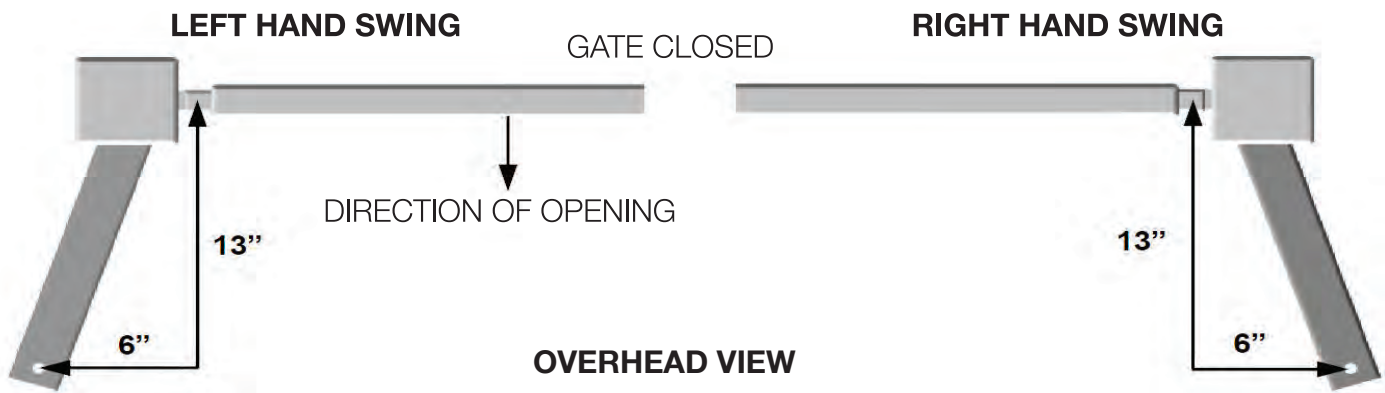


FIGURE 5 - 1 PULL TO OPEN INSTALLATION - LEFT AND RIGHT HAND SWING PIVOT POINT

#### **VERTICAL POSITION OF PIVOT ARM**

The top edge of the Pivot Arm will be located 1/2" below the center line for the gate bracket. The Pivot Arm must be level when secured.

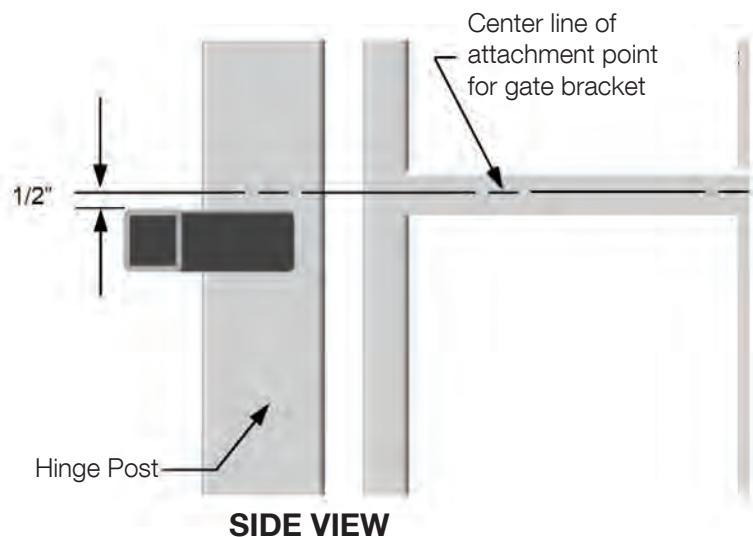


FIGURE 5 - 2 VERTICAL PIVOT POSITION



## 5.2 - Push to open installation

### PIVOT ARM INSTALLATION - Location of Pivot Point

Measurements are taken from the center of pivot of the gate hinge.

The pivot arm needs to be securely mounted to the hinge post or equivalent mounting surface. It is recommended to weld the pivot arm to a metal post. In order to achieve the correct articulation, geometry and rate of speed of the gate it is critical that the measurements below are followed. The pivot arm may need to be cut to achieve the correct placement of the actuator mounting hole. Measurements are taken from the center of pivot of the gate hinge.

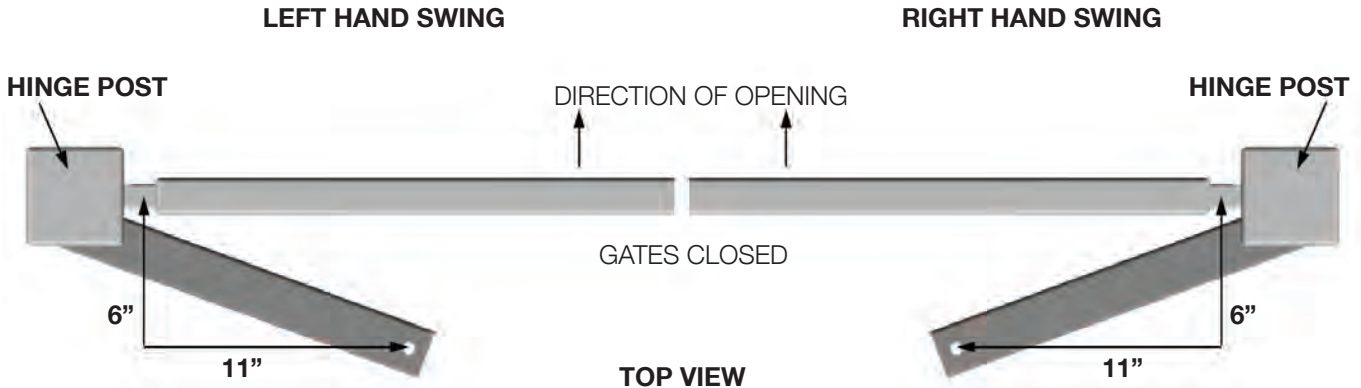


FIGURE 5 - 3 PIVOT ARM INSTALLATION

### Vertical Position Of Pivot Arm

The top edge of the Pivot Arm will be located 1/2" below the center line for the gate bracket. The Pivot Arm must be level when secured.

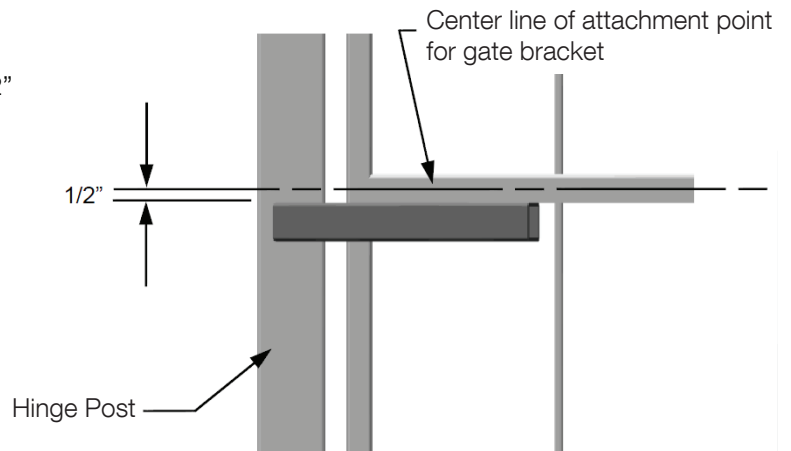


FIGURE 5 - 4 HINGE POST

## 5.3 - Actuator mounting

Mount the actuator to the pivot arm as shown.

Please notice the washer goes below the actuator flange.

The lock nut should be tight to prevent movement or shifting when the actuator is running. This will also prevent excessive "bounce" or "wobble" when the gate stops moving.

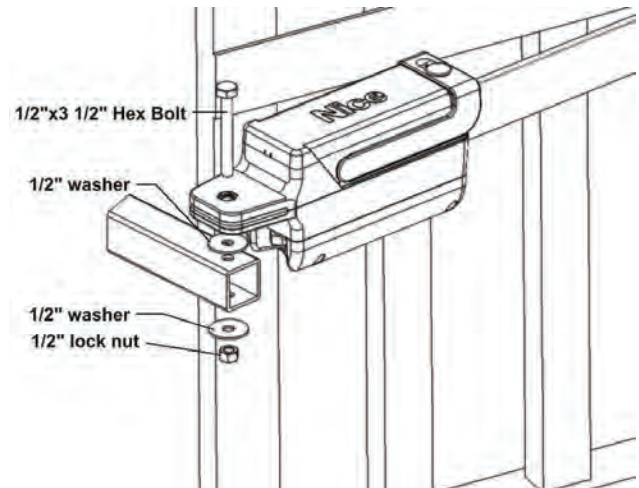


FIGURE 5 - 5 ACTUATOR MOUNTING

### 5.4 - Control box mounting

Mount the control box within 4 feet of the pivot arm. Use mounting hardware capable of supporting the weight of the control box with the battery installed. Do not mount the control box where the person using the push button on side of the box can come in contact with the gate.

Set battery inside of control box with terminals toward the front (Do not use any battery with side terminals).

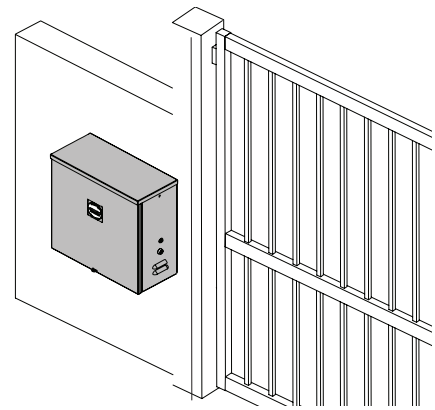


FIGURE 5 - 6 CONTROL BOX MOUNTING

### 5.5 - Incoming power wiring

Power input connections should be wired as follows:

#### Solar Panel

Connect wires to the solar panel terminal block. The positive wire of the panel connects to the left terminal marked “+”.

Note: If the panel is connected backwards a red LED will illuminate below the terminal. If solar power is to be used it will be necessary to program control board for STANDBY operation.

#### Battery

Connect wires to the battery terminal block. The positive wire of the battery connects to the left terminal marked “+”.

**NOTE**

If the battery is connected backwards a red LED will illuminate below the terminal.

#### Main Power - This terminal block is for incoming 10-35VDC power only!

Connect wires to the main power terminal block. Positive of the power supply connects to the left terminal marked “+”. This input should only be used with a power supply capable of supplying 10-35VDC at 20 amps.

**NOTE**

If supply is connected backwards, a red LED will illuminate below the terminal. If supply is connected properly, a green LED will illuminate.

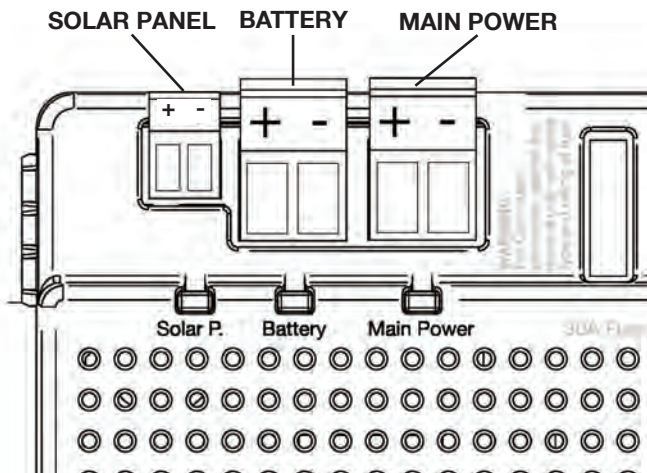
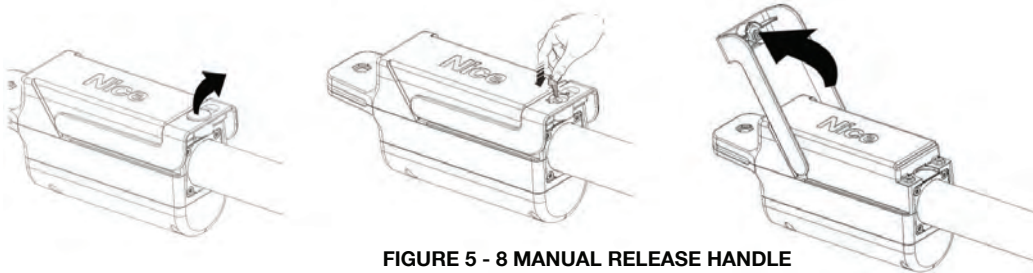


FIGURE 5 - 7 INCOMING POWER WIRING

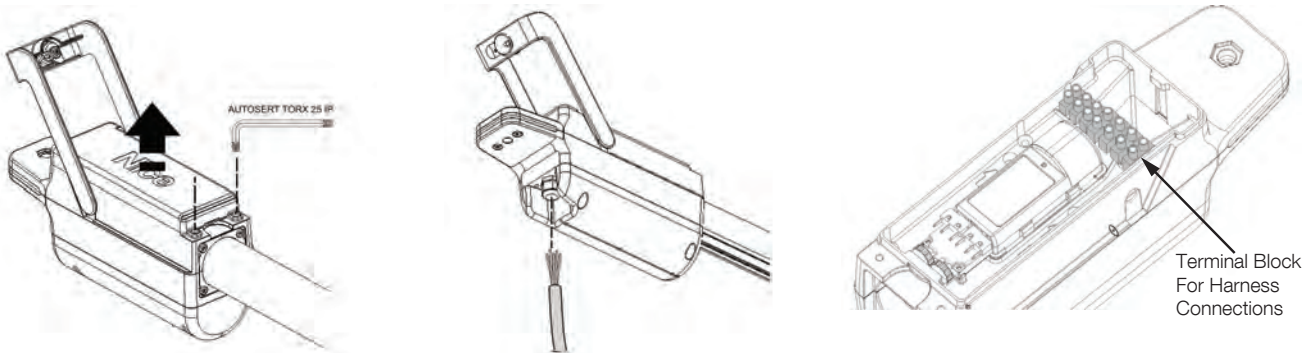
## 5.6 - Titan actuator wiring

Using the supplied key, unlock the manual release handle. Lift upwards on the release handle as shown.

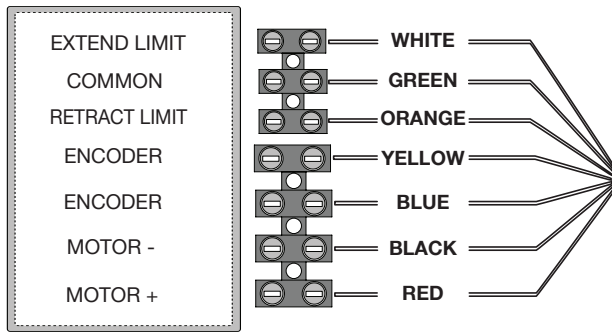


**FIGURE 5 - 8 MANUAL RELEASE HANDLE**

With the release handle up, remove the screws from the limit cover and remove the cover. On the bottom of the actuator loosen the strain relief nut and insert the wire into the actuator housing. The connections are on the top of the atuator behind the limit assembly.



**FIGURE 5 - 9 TITAN ACTUATOR WIRING**



**FIGURE 5 - 10 TITAN ACTUATOR WIRING**

Connect the wiring to the actuator terminal block as shown.

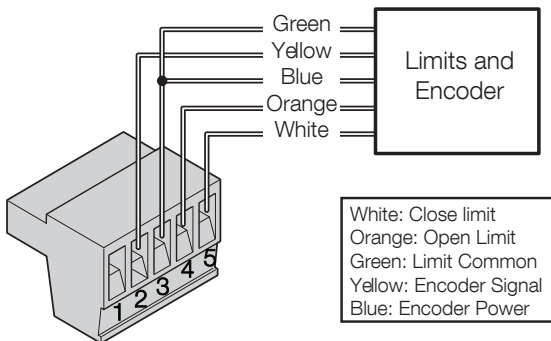
**NOTE**

These units are still in Beta production and wiring may not match exactly as shown. If you experience problems during the installation or programming, please contact technical support at 800-226-0178 for assistance.

### TITAN ACTUATOR WIRING (STANDARD)

#### Actuator Limit Switch And Smart Sensor Wiring

Connect the actuator cable to the 5-pin connector as shown below. These connections enable the limit switch and smart sensor inputs into the gate controller.

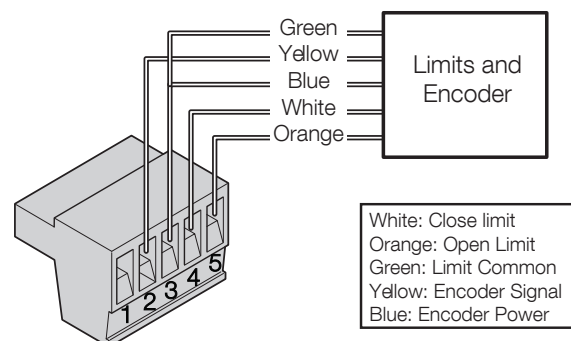


**FIGURE 5 - 11 TITAN ACTUATOR WIRING (STANDARD)**

### TITAN ACTUATOR WIRING (PUSH TO OPEN)

#### Actuator Limit Switch And Smart Sensor Wiring

Connect the actuator cable to the 5-pin connector as shown below. These connections enable the limit switch and smart sensor inputs into the gate controller.



**FIGURE 5 - 12 TITAN ACTUATOR WIRING (PUSH TO OPEN)**

### Actuator Motor Wiring

Connect the actuator motor leads to the 3-pin connector as shown below.

#### NOTE

If the gate moves in the opposite direction from what is expected, reverse the actuator wiring from what is shown. (Red to Pin 3, Black to Pin 1)

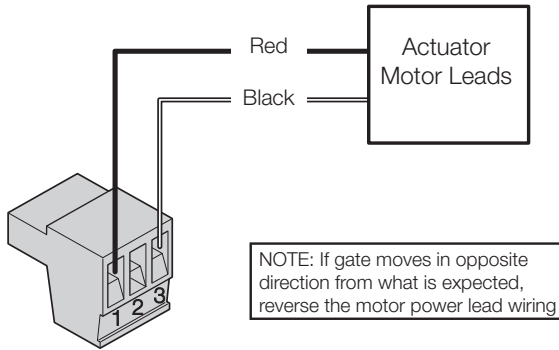


FIGURE 5 - 13 ACTUATOR MOTOR LEADS

### Actuator Motor Wiring

Connect the actuator motor leads to the 3-pin connector as shown below.

#### NOTE

If the gate moves in the opposite direction from what is expected, reverse the actuator wiring from what is shown. (Red to Pin 3, Black to Pin 1)

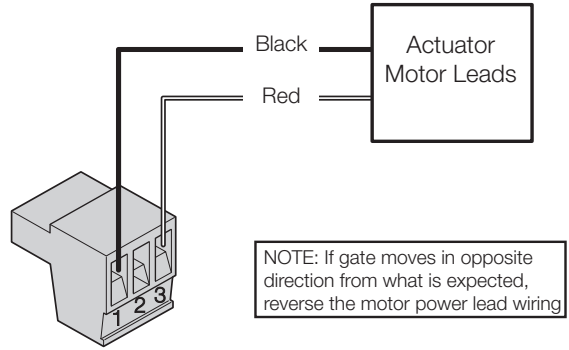


FIGURE 5 - 14 ACTUATOR MOTOR LEADS

## 5.7 - Limit and motor connections to the board

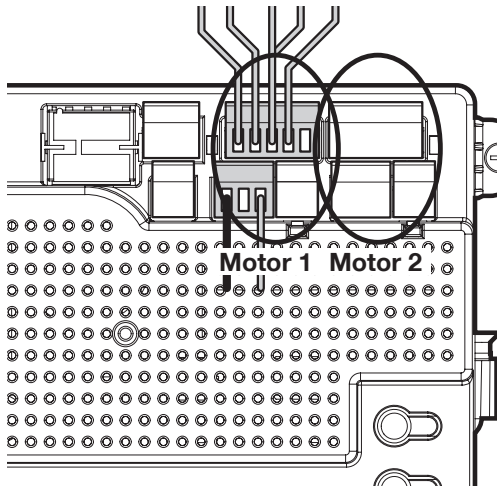


FIGURE 5 - 15 LIMIT AND MOTOR CONNECTION TO THE BOARD

Install the 5 and 3-pin connector for motor 1 into the connection labeled "Motor 1" on the controller as shown.

For a dual gate installation, install the 5 and 3-pin connector for the second operator into the connection labeled "Motor 2".

#### NOTE

**Motor 1:** Make sure the motor lead connector is plugged in below the limit 5 pin terminal connector.

## 5.8 - Limit switch adjustment

1. From the manufacturer, these units will be in the fully retracted position.
2. If the actuator is not mounted to the pivot arm, do so at this time, before proceeding (see Sec. 5.3).
  - a. For a standard **pull to open** application, bring the gate leaf to the fully open position.
  - b. For a reversed **push to open** application, bring the gate leaf to the fully closed position.
3. Bring the bracket end of the actuator (with the gate bracket attached) into contact with the gate and mark placement.
4. Remove the extension tube from the bracket and weld or bolt the bracket to the gate using 3/8" bolts, lock washers and nuts.
5. Bolt the extension tube of the operator to the gate bracket.
6. Engage the manual release for the operator to allow for manual operation (see figure 5-8).
7. Remove the top cover to expose the limit assembly.
8. Manually move the gate to the:
  - a. Fully closed position for **pull to open** applications
  - b. Fully open position for **push to open** applications

**A clicking sound will be heard as this manual operation is performed. This sound is the extend limit cog (blue) self-adjusting.**

9. Manually move the gate back to the:
  - a. Fully open position for **pull to open** applications
  - b. Fully closed position for **push to open** applications
10. Disengage the manual release for the operator to engage the drive train.
11. Plug the actuator into the control board (see Sec. 5.9)
12. Put the control board in "LEARN MODE" by pressing the FUNCTION button, select "LEARN", press the OK button, select "Swing", press OK, select "LIGHT", "AVERAGE" or "HEAVY" (depending on the gate) and press OK a last time. If done correctly the display should read "LEARN" with "ENTER" flashing below.
13. Turn the knob controlling the linear motion of the retract limit cog (white) to bring it into contact with the limit switch. If this is done correctly you will see:
  - a. The LED below the motor connection port being used, illuminate green indicating the open limit is active for a **pull to open** application.
  - b. The LED below the motor connection port being used, illuminate red indicating the closed limit is active for a **push to open** application.
14. Press and hold:
  - a. The close button until the close limit is activated for a **pull to open** application.
  - b. The open button until the open limit is activated for a **push to open** application.
15. If the location of the gate is not the location desired, engage the manual release, move the gate to the position desired and disengage the manual release.
16. Turn the knob controlling the linear motion of the extend limit cog (blue) to bring it into contact with the limit switch. If this is done correctly you will see:
  - a. The LED below the motor connection port being used, illuminate red indicating the close limit is active for a **pull to open** application.
  - b. The LED below the motor connection port being used, illuminate green indicating the open limit is active for a **push to open** application.
17. Press and hold:
  - a. The open button until the open limit is activated for a **pull to open** application.
  - b. The close button until the close limit is activated for a **push to open** application.
18. If the location of the gate is not the location desired, engage the manual release, move the gate to the position desired and disengage the manual release. Then repeat step 13 above.

**Steps 14 thru 18 above may need to be repeated if the open and close positions established during the learn cycle need adjustment.**

**\*Once the operator has been learned and the location of the limits is correct, replace the top cover.**

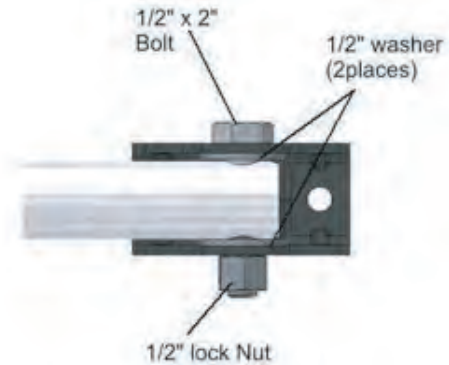


FIGURE 5 - 16 GATE BRACKET MOUNTING

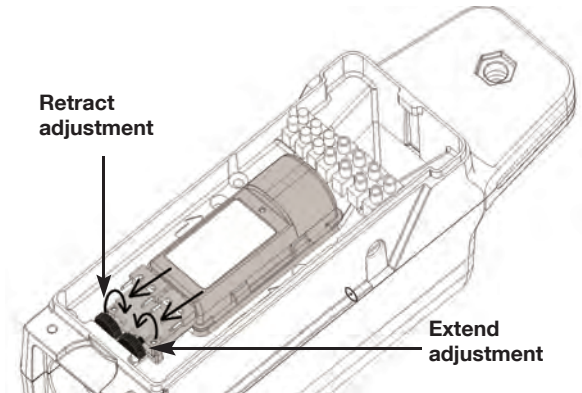


FIGURE 5 - 17 LIMIT SWITCH ADJUSTMENT

### NOTE

Turning the knob in the direction shown above will move the limit cog toward the limit switch

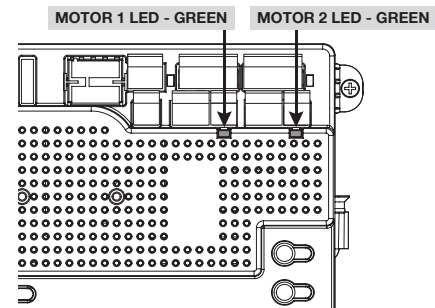


FIGURE 5 - 18 LEARNING MODE - OPEN LIMIT

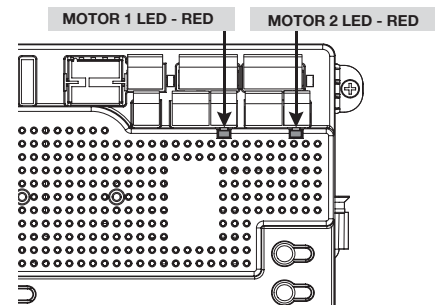
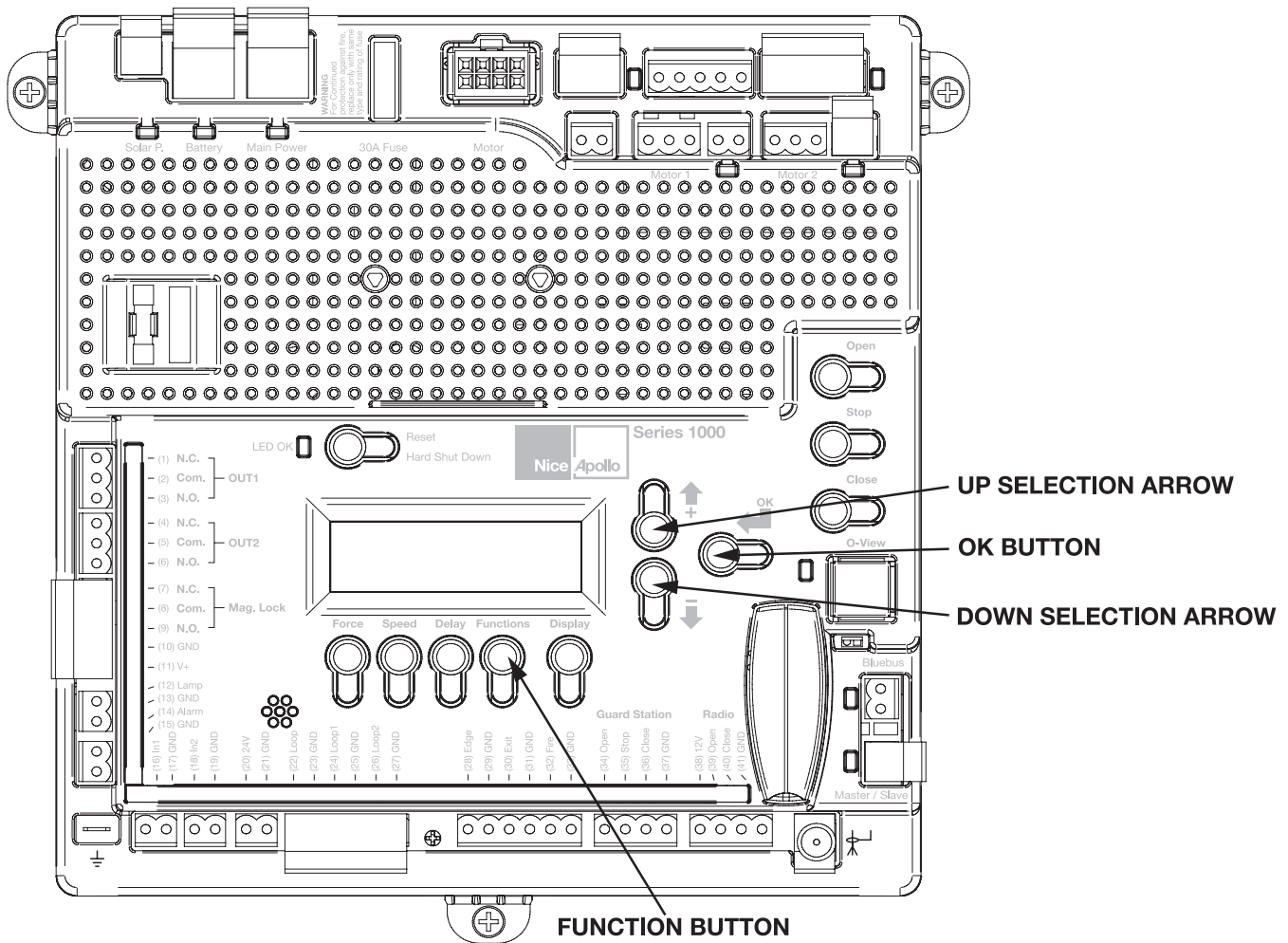


FIGURE 5 - 19 LEARNING MODE - CLOSED LIMIT

## 5.9 - 1050 Controller learning procedure

Nice has taken great care to simplify the installation, operation and safety of this device and to ensure longevity and reliability of the unit over time. The learning procedure consists of the following steps shown below:



**NOTE**

The control board is already in **LEARNING MODE** when shipped.

**If not in learning mode:**

1. Press FUNCTION then press OK.
  2. Using the arrow buttons select SWING then press OK.
  3. Select LIGHT, AVERAGE OR HEAVY, then press OK
1. Test the motor direction by pressing and holding CLOSE. If the gate instead OPENS swap the RED and BLACK motor leads and retest to verify correct operation. Set limits according to the operators installation manual. **Limits and motor direction MUST be set prior to learning the board!**
  2. Press and hold the Open or Close button on the gate controller until the gate is 50% open.
  3. Press ENTER to allow the control board to scan for attached items, such as sensors, photo-eyes and other safety devices and start the learning sequence. The gate will open partially then stop. This is being done, so that the control board can sense the type and operational condition of the drive motor. The gate will then run to the closing limit (one leaf at a time in case of dual application: "slave" closes first then "master" follows), so that it can properly sense the close limit switch. The gate will then fully open to test the open limit switch then fully close at high speed. The gate should be fully learned by the control board at this point.

The gate opener is now programmed for basic usage.

## 6 - ACCESSORY INPUTS AND OUTPUTS

### 6.1 - OUTPUTS

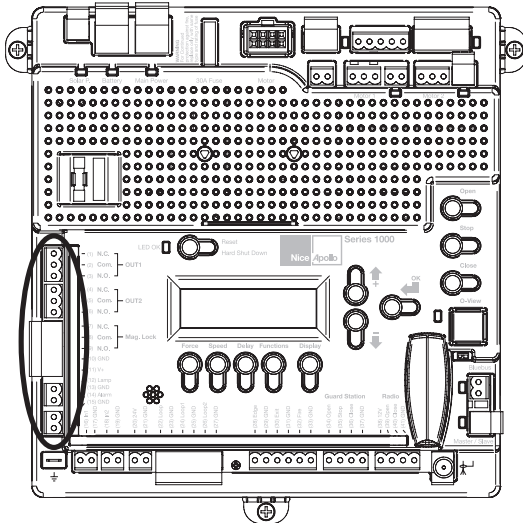


FIGURE 6 -1 BOARD OUTPUTS

#### GATE OPERATOR ACCESSORY OUTPUTS:

**OUT1 and OUT2:** Individual, isolated relays provide COMMON, NORMALLY OPEN, and NORMALLY CLOSED dry contacts for switching accessories based on programming of the "Auxiliary IO" function. These outputs are programmed in the "FUNCTION Auxiliary I/O" menu.

**Magnetic Lock:** Provides fused power (1.85A max) and isolated relay COMMON, NORMALLY OPEN, and NORMALLY CLOSED dry contacts for electrically powered and maintained magnetic locks. The output time for magnetic lock deactivation may be adjusted using Warning Lamps.

#### Lamp:

to indicate gate operation. This output is active when the gate is operating (Opening and Closing). Lamp Delay sets the amount of time the lamp accessory output is activated prior to gate movement. Settings from 0 to 5 seconds with a step of 0.5 seconds.

**Alarm:** Provides fused power (0.5A @ 12VDC) to drive an alarm siren to signal the occurrence of a hard shutdown, caused by 2 consecutive entrapment events (signals). This alarm output is reset by pressing the "Reset Hard Shutdown" button on the front panel or activating the "FIRE" input.

### 6.2 - INPUTS

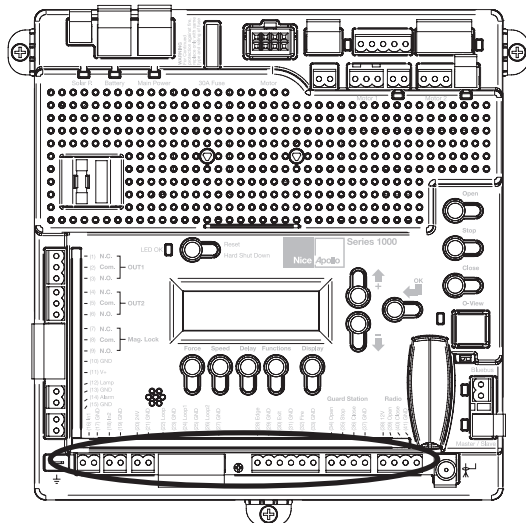


FIGURE 6 -2 BOARD INPUTS

#### GATE OPERATOR ACCESSORY INPUTS:

**Auxiliary Inputs 1 (16) and 2 (18):** These digital inputs may be connected to the digital outputs of accessories and programmed to activate or control the gate operator in a number of different modes. Shorting the pins through a dry contact activates the programmed settings for these inputs. These inputs are programmed in the "FUNCTION Auxiliary I/O" menu.

**SAFETY LOOP Input:** (22) Dry contact input that can be programmed for an inductive safety loop or photo-eye detector. Shorting pin 22 to GND reverses a closing gate to the full open position. The opened gate is held open for as long as the LOOP input is active.

**SHADOW (LOOP 1) Input:** (24) Dry contact input that can be programmed for an inductive safety loop or photo-eye detector. Shorting the LOOP 1 input (24) to GND maintains an OPEN gate fully open and a CLOSED gate fully closed until deactivated.

Setting the LOOP1 input to "Photo Mode" causes the moving gate to stop, then reopens the gate when the LOOP1 input is deactivated.

**ENTRAPMENT (LOOP 2) Input:** (26) Dry contact input that can be programmed for an inductive safety loop or photo-eye detector. Shorting the LOOP2 input (26) to GND while the gate is opening cause the gate to close to the fully closed position. This loop input is intended for use with safety sensors to prevent entrapment between the opening gate and an adjacent wall or structure.

**Edge Input:** (28) This input may be configured as "DIGITAL" or "ANALOG" as required by the sensor type. When configured as "DIGITAL", this is a dry contact input; otherwise when configured as "ANALOG", the input must measure 8200ohms. When the input is activated it stops the gate regardless of direction of travel, momentarily reverses it then stops.

**Exit Input:** (30) Dry contact input for a vehicle exit sensor. Shorting this input to GND opens gate from the closed position and holds gate open with maintained input or reverses gate if closing.

**Fire Input:** (32) Dry contact input for a fire department control switch. Opens the gate and holds the gate open until the control switch is deactivated. This input is "hold to run". Auto-close is disabled when this input is activated. Also clears hard shutdown.

#### GUARD STATION

**Guard Station Open:** (34) Dry contact input for a guard station open switch. Momentarily shorting the digital input to GND opens the gate to the full open position with the subsequent auto-close feature enabled.

**Guard Station Stop:** (35) Dry contact input (Normally Closed) for a guard station stop switch. Momentarily opening this input stops the opening gate at its current position. While this input is activated, all other inputs are disabled and are not functional.

**Guard Station Close:** (36) Dry contact input for a guard station close switch. Momentarily shorting the digital input to GND closes the gate (master and slave).

#### RADIO

**Radio Open:** (39) Dry contact input for an accessory radio open switch. Momentarily shorting the digital input to GND opens the gate to the full open position with the subsequent auto-close feature enabled.

**Radio Close:** (40) Dry contact input for an accessory radio close switch. Momentarily shorting the digital input to GND closes the gate.

**Radio Input:** Open/Close: (39 and 40) If you tie open and close together the unit will operate as a Step by Step command each time the input is shorted to GND, it will either OPEN, STOP or CLOSE.

## 6.3 - COMMUNICATION BUSES

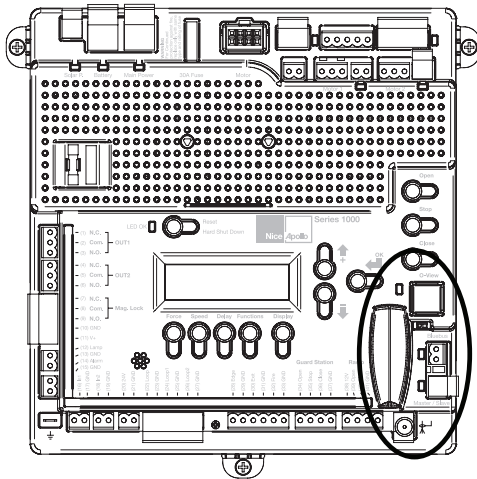


FIGURE 6.3 COMMUNICATION BUSES

### OVIEW

Programming and diagnostic unit which connects directly to the gate controller and is part of the Nice "Opera" control system. The unit can be used in "stand-alone" mode via its front-panel keypad, or it may be accessed via a Bluetooth or cellular-enabled PDA, PC, or Smartphone when used with the O-View Software Suite. This unit, when matched with the OVIEW Bluetooth or GSM modules, enables remote control and management of the gate controller. Remote control functions include most of the programming functions that are available at the front panel LCD on the control board as well as software updates.

**OVBT:** Bluetooth module for OVIEW and the "O-View Software Suite" application for PC, PDA, or Smartphone for localized wireless control of the gate controller.

**OVBTGSM:** Combination GSM and Bluetooth module that plugs into the OVIEW and provides cellular phone access through the "O-View Software Suite" application for PC, PDA, or Smartphone, for wireless local, national, and international control of the gate controller.

**O-VIEW Software Suite:** Provides desktop or Smartphone level control of the gate controller. Other benefits include software updates that can be made as new versions of software are made available.

### BLUEBUS ACCESSORIES

**MOTB:** Moon Touch programmable keypad with secure codes (up to 9 digits per code if required) to control gate opening and closing. Connects to the 2-wire BlueBUS connector with inexpensive unshielded twisted-pair wire.

**MOFB:** Photocell transmitter and receiver pair that connects to the 2-wire BlueBUS connector with inexpensive unshielded twisted-pair wire and is a non-contact sensor for entrapment protection as specified in UL325, Section 31.1 "General Entrapment Protection Provisions".

### MASTER/SLAVE - ONLY USED IN 24V COMMERCIAL OPERATORS

The gate operator includes a two-pin connector designed to link two separate gate operators together as a Master/Slave pair. The Master/Slave configuration is enabled by connecting two gate operators with simple, unshielded twisted-pair wire (Max.100 ft.). All entrapment sensors, switch inputs, receiver controls, and outputs must be wired to the gate operator designated as the "Master". The following procedure outlines the process for configuring the Master/Slave pair.

Perform the "Learn" process to configure open and close limits with the gate for each operator. See the "Programming Quick Start" procedures in this manual for a description of the gate learning process.

On the Master operator, select Function -> Adv. Settings -> Remote Mst. Slv. Then select On -> Master. The red LED associated with the Master/Slave connector will illuminate.

On the Slave operator, select Function -> Adv. Settings -> Remote Mst. Slv. Then select On -> Slave. The red LED associated with the Master/Slave connector will illuminate.

The Master/Slave pair is now configured. The Slave gate operator will perform identical open/close/stop functions in tandem with the Master gate operator.

### Programming the plug-in receiver and remote controls Nice

**Plug in Receiver:** The Nice 433Plug-In Receiver provides up to 15 channels for specific control of individual gate functions. The receiver includes built-in programming functions for adding or removing Nice wireless remote controls to/from a gate installation. The following procedures detail the steps to assign a remote control, add a new remote control, delete a single remote control, or remove all remote controls from the receiver memory.

### Programming the Nice 2-Button or 4-Button Remote Control with the Nice Plug-In Receiver.

These procedures apply to the Nice wireless remote control. These procedures assign factory default controls automatically to the remote control.

1. Have a functioning Nice 2-button or 4-button remote control with a battery installed prior to programming the remote control.
2. Press and hold the button on the side of the Nice receiver until the led illuminates green on the Nice receiver, then release the button.
3. Within 10 seconds, press and hold any key on the Nice remote control until the led in the Nice receiver blinks green 3 times, indicating that the Nice is programmed to control the receiver.
4. After the led on the Nice receiver blinks green 3 times, another 10 second interval is started to program another Nice remote control if desired. Repeat step 3 to program the additional Nice remote control. Step 3 may be repeated as many times as necessary to program all available Nice remote controls.
5. Verify that the Nice remote control(s) can control the gate by pressing one or more buttons individually on the remote control(s).

### Add new remote control to the Nice Plug-In Receiver

A Nice remote control that has been programmed to control a Nice receiver may be used to create other Nice remote controls for the same receiver. This procedure needs to be performed within 10 to 20m (30 to 60 feet) of the Nice receiver, but the Nice receiver does not need to be physically accessed.

1. Press and hold any button on the non programmed Nice remote control for at least 5 seconds, then release the button, taking note of the button that was pressed.
2. Press the same button on the programmed Nice remote control three times.
3. Press the same button in step 1 on the non programmed Nice remote control and release.
4. It is recommended to test the new copy of the Nice remote control with the assigned gate controller.

**NOTE: This procedure will affect all Nice receivers within radio range.**

### Deleting a Single Nice Remote Control from the Nice Plug-In Receiver Memory

A Nice remote control that has been programmed to control a Nice receiver may be removed from the Nice receiver memory without affecting other assigned remote controls. This procedure needs to be performed at the Nice Plug-In Receiver with the affected Nice remote control.

1. Press and hold the button on the side of the Nice receiver until the led on the Nice receiver illuminates green and keep the button pressed. The led will illuminate after approximately 4 seconds.
2. Press and hold any button on the Nice remote control until the led on the Nice receiver blinks 5 green flashes
3. Release the button on the side of the Nice receiver.
4. It is recommended to verify that the non programmed Nice remote control no longer controls the gate.



**Deleting all Nice transmitters from the Nice Plug-In Receiver Memory.**

All programmed remote controls may be removed from the Nice plug in receiver memory . This procedures need to be performed at the gate controller.

1. Press and hold the button on the side of the Nice receiver until the led on the Nice receiver illuminates green and keep the button pressed.
2. Watch the led and on the receiver and verify the following sequence in the led.
3. Within 4 seconds after pressing the button (approx.) the green led illuminates.
4. Within 8 seconds after pressing the button (approx.) the green led turns off.
5. Within 12 seconds after pressing the button (approx.) the green led starts flashing
6. Count the green led flashes on the Nice receiver. On EXACTLY the 3<sup>rd</sup> flash, release the button on the Nice receiver.
7. It is recommended to test the Nice remote controls, if available, with Nice plug in receiver to verify that it no longer affects the gate controller.

**7 - 120VAC POWER WIRING**

**DO NOT WIRE AC POWER TO THE 1050 CONTROL BOARD!**

**THE CONTROL BOARD OPERATES ON 10 - 35 VDC ONLY!**

**This section intended for residential systems where a 120VAC transformer will be used**

To reduce the risk of SEVERE INJURY or DEATH:

- Disconnect power to the gate operator by manually opening its dedicated circuit breaker before making any mechanical or electrical adjustments.
- Use a 20 Amp dedicated circuit breaker for each installed gate operator.
- Open dedicated circuit breaker supplying power to this gate operator BEFORE a new installation or making any modifications to an existing installation of this gate operator.
- All wiring connections MUST be made by a qualified individual
- Run individual circuits in separate U.L. listed conduits. Do not combine high voltage (120VAC) power wiring and low voltage (+12VDC to +24VDC) control wiring in the same conduits.
- Use the information in table 1 to determine high voltage wire size requirements. The distance shown in the chart is measured in feet from the operator to the power source. If power wiring is greater than the maximum distance shown, it is recommended that a service feeder be installed. When large gauge wire is used, a separate junction box must be installed for the operator connection. The wire table is based on stranded copper wire. Wire run calculations are based on a 110 VAC power source with a 3% voltage drop on the power line, plus an additional 10% reduction in distance to allow for other losses in the system.

**Table 1 - MAXIMUM RUN (FT) PER WIRE GAUGE**

110V AWG	14	12	10	8	6	4
MAX RUN (ft)	180	280	460	700	1150	1800

The gate operator system should be grounded through the earth ground in the AC mains wiring system (GREEN WIRE). This ground connection will prevent dangerous currents from appearing on the metal control box, the actuator, or the gate itself.

**DO NOT WIRE AC MAINS POWER TO THE METAL CONTROL BOX WITHOUT AN EARTH GROUND CONNECTION!**



FIGURE 7-1 EQUIPMENT SAFETY WARNINGS

**8 - SOLAR PANEL CHART**

This Apollo Gate Operator is 12 Volt DC (Direct Current) powered. A 12 Volt sealed battery (33 ampere hour minimum for AC charged systems, 70 ampere hour minimum for solar charged systems) with connecting posts located on the top is recommended.

The following table should be used as a guide for capacity of operation of operators only, additional options and accessories may reduce the daily usage. Please note that the charge capability of solar panels will vary with different geographical locations.

Daily cycles	1-10	1-20	1-40	1-60	1-80	80+
5 watt solar panel	*					
10 watt solar panel		*				
20 watt solar panel (requires regulator)			*			
30 watt solar panel (requires regulator)				*		
40 watt solar panel (requires regulator)					*	
1.5 amp battery charger					*	
10 amp battery charger						*

**Note: Double the amount of solar wattage for dual gate operators**

Nice Apollo operators with the 1050 board that are used in solar applications need to be put into "Standby" mode.

To do this, press Functions – scroll to #8 "Standby" – Press OK – Scroll to desired amount of time before system enters Standby mode – Press OK. Once this is done, the operator will enter a Standby mode after the set time when the operator is not moving or in the auto-close countdown.

Things to note in Standby:

1. Display will be off and only a "heartbeat" will be present at the LED OK
2. Voltage at #20 (24 volts) and #38 (12 volts) will turn off - **DO NOT CONNECT ENTRY OR EXIT DEVICES HERE**
3. BlueBus connection is non functional
4. Master/Slave syncing is non functional (used for commercial operators only)

Connection of the solar panel(s) may be made at the top left corner of the board at "Solar P" (regulated charging to the "Battery" via the controller in the board) – note that the maximum output of the regulator in the 1050 board is 1.5A. If the installation requires larger than a 30W solar panel – an off-board regulator should be used and connected directly to the battery.

## 9 - OPTIONAL INPUTS

### 9.1 - FIRE DEPARTMENT CONNECTION

32 FIRE  
33 GND

Dry contact input for a fire department control switch. Normally Open (NO) contact must be shorted to ground through a switch to open the gate. The FAIL SAFE connector which is shorted at the factory with a jumper (Normally Closed NC), may be wired in parallel with the Fire input to release the motor in the event of an emergency entry by the fire department during a power failure. Opening the FAIL SAFE contacts allows the gate to be pushed open by hand.

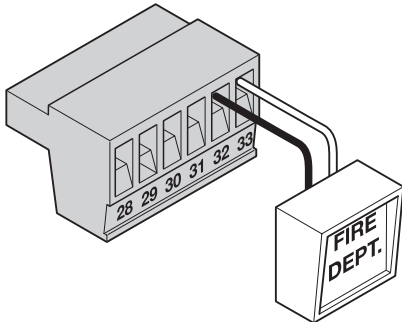


FIGURE 9 - 1 FIRE DEPARTMENT INPUT

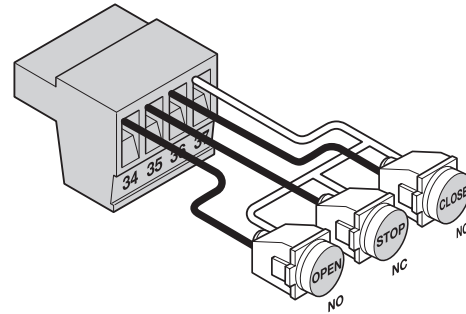


FIGURE 9 - 3 GUARD STATION INPUTS

### 9.4 - EXIT & EDGE INPUTS WIRING DIAGRAM

28 EDGE  
29 GND  
30 EXIT  
31 GND

The EDGE input may be configured as a monitored ANALOG input, or DIGITAL (NC or NO) input. The EDGE sensor input is intended for ANSI/UL 325 listed gate edge sensors to protect against entrapment and hazardous pinch points along the moving edge of the closing gate. The EXIT sensor input is provided to activate to open the gate, or re-open a closing gate, upon sensing an exiting vehicle.

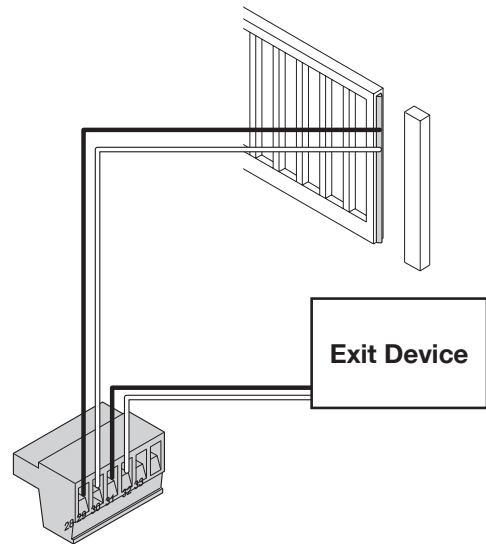


FIGURE 9 - 4 EXIT AND EDGE INPUTS

### 9.2 - MAGNETIC LOCK CONNECTION

7 NC  
8 Com (Common)  
9 NO  
10 GND  
11 V+ (Voltage is determined by incoming power supply)

This connection is used to install the magnetic lock. In this instance a gate can be locked magnetically to prevent a forced opening. Consult lock manual for specifics on installation and wiring

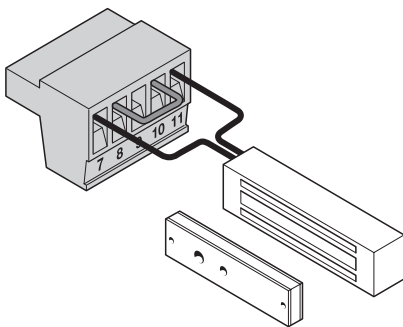


FIGURE 9 - 2 MAGNETIC LOCK WIRING (EXAMPLE)

### 9.3 - GUARD STATION

34 OPEN  
35 STOP  
36 CLOSE  
37 GND

With the Guard Station switches installed, the user can operate the gate by pushing the respective buttons for the command that is desired. Gate Open and Close are controlled by NORMALLY OPEN (NO) and Stop is controlled by NORMALLY CLOSED (NC) momentary switches.

**NOTE:** If the guard station inputs are not used STOP (35) and GND (37) need to be tied together

## 10- RADIO RECEIVER CONNECTION (THIRD PARTY)

38 12V  
39 OPEN  
40 CLOSE  
41 GND

The customer supplied radio receiver allows the gate operator to be operated via remote, such as wireless key-card readers or user remote controls.

Connecting the Open (39) and Close (40) pins together with a receiver enables single-button gate control. This configuration allows a single button to control the gate in the following sequence:

Press - Gate Open  
Press - Gate Stop  
Press - Gate Close  
Press - Gate Stop

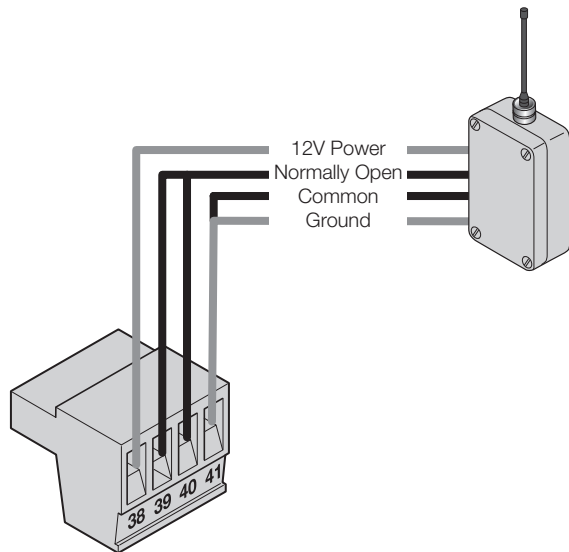


FIGURE 10-1 RADIO RECEIVER

## 11 - INSPECTION AND OPERATION

Proper inspection of all equipment is required to ensure continuous functionality, safety and to ensure reliable operation in all weather conditions. Inspect electrical assemblies and wiring installations for damage, general condition, and proper functioning to ensure the continued satisfactory operation of the electrical system. Adjust, repair, overhaul, and test electrical equipment and systems in accordance with the recommendations and procedures in the gate operator system and/or component manufacturer's maintenance instructions.

Replace components of the electrical system that are damaged or defective with identical parts, with manufacturer's approved equipment, or its equivalent to the original in operating characteristics, mechanical strength, and environmental specifications. A partial list of suggested problems to look for and checks to be performed are listed below:

- 11.1 Damaged, discolored, or overheated equipment, connections, wiring, bearing caps and installations.
- 11.2 Excessive heat or discoloration at high current carrying connections. (look for bluing or heat affected metal).
- 11.3 Misalignment of electrically driven equipment. (Causes strain on pulley assemblies and bearings).
- 11.4 Poor electrical bonding (broken, disconnected or corroded bonding strap) and grounding, including evidence of corrosion.
- 11.5 Dirty equipment and connections. Clean equipment and connections.
- 11.6 Improper, broken, inadequately supported equipment, wiring and conduit, loose connections of terminals, and loose ferrules.
- 11.7 Poor mechanical or weld joints. Broken welds.
- 11.8 Condition of circuit breaker and fuses. Ensure that they are of the correct type and amperage.
- 11.9 Insufficient clearance between exposed current carrying parts and ground or poor insulation of exposed terminals. All exposed connections must be covered (prevent arcing between exposed parts, and electrical shock).
- 11.10 Broken or missing wire, connectors, etc.
- 11.11 Operational check of electrically operated equipment such as motors, inverters, generators, batteries, lights, protective devices, etc. Ensure proper functionality of all systems during inspections.
- 11.12 Ensure safety placards and warning signs are present as specified within this document. Ensure proper functionality of all safety devices as specified. Non-functioning or malfunctioning safety devices should be replaced immediately.

**12 - GENERAL LAYOUT AND SAFETY ACCESS**

Entrapment Protection Inputs - Typical Installation Diagram Utilizing Loop Sensors and Photocells

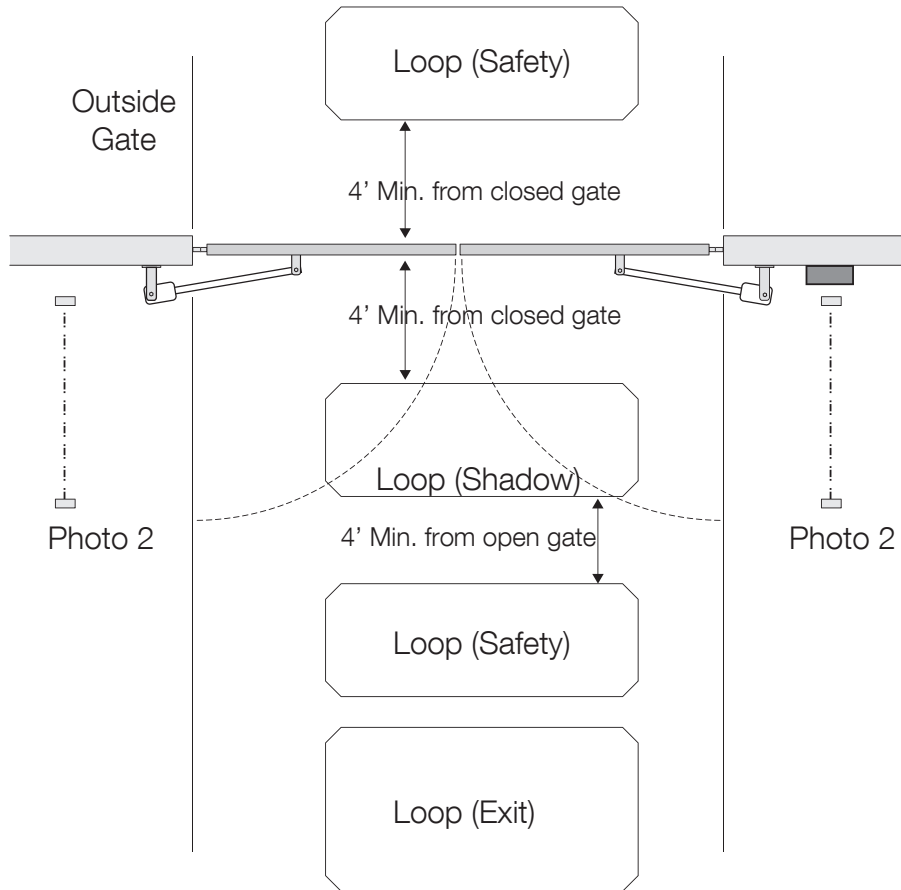


FIGURE 12 -1 LAYOUT FOR IN-GROUND LOOPS

Entrapment Protection Inputs - Typical Installation Diagram Utilizing Photocells

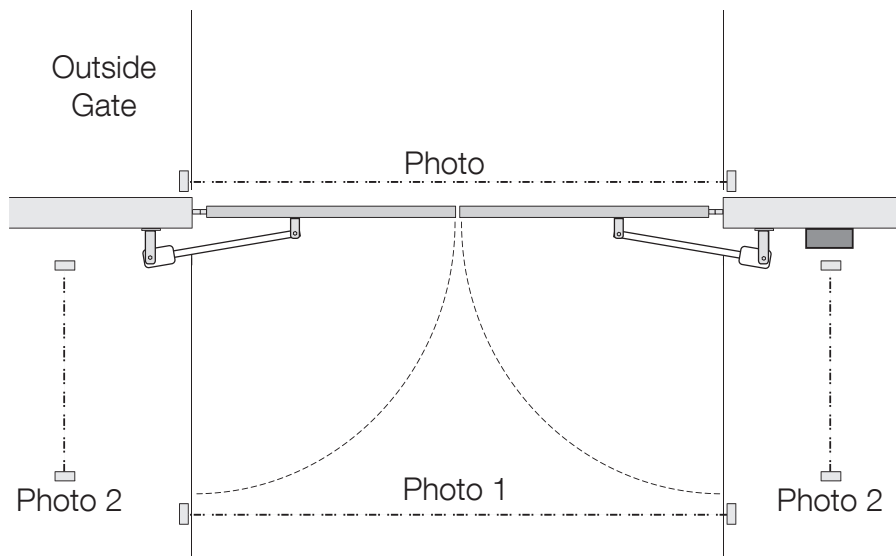


FIGURE 12 -2 LAYOUT FOR PHOTOCELLS

## SECTION 13 - ACCESSORIES AND SENSORS

### EXTERNAL ENTRAPMENT PROTECTION

Non-contact and contact sensors must be installed individually or in combination with each other to provide external entrapment protection.

Care should be exercised to reduce the risk of nuisance tripping, such as when a vehicle trips the sensor while the gate is still moving, and one or more contact sensors shall be located where the risk of entrapment or obstruction exists, such as the perimeter reachable by a moving gate or barrier

A hardwired contact sensor shall be located and its wiring arranged so that the communication between the sensor and the gate operator is not subjected to mechanical damage.

A wireless contact sensor such as one that transmits radio frequency (RF) signals to the gate operator for entrapment protection functions shall be located where the transmission of the signals are not obstructed or impeded by building structures, natural landscaping or similar obstruction.

### DURING INSTALLATION

- DISCONNECT POWER at the control panel before making any electric service power connection.
- Be aware of all moving parts and avoid close proximity to any pinch points.
- Know how to operate the manual release.
- Adjust the unit to use the minimum force required to operate the gate smoothly even during mid-travel reversing.
- Place controls a minimum of 8 feet away from the gate so that the user can see the gate and operate controls but cannot touch the gate or gate operator while operating the controls.
- Warning signs must be placed on each side of the gate or in high-visibility areas to alert of automatic gate operations.

**⚠ WARNING  
AVERTISSEMENT**

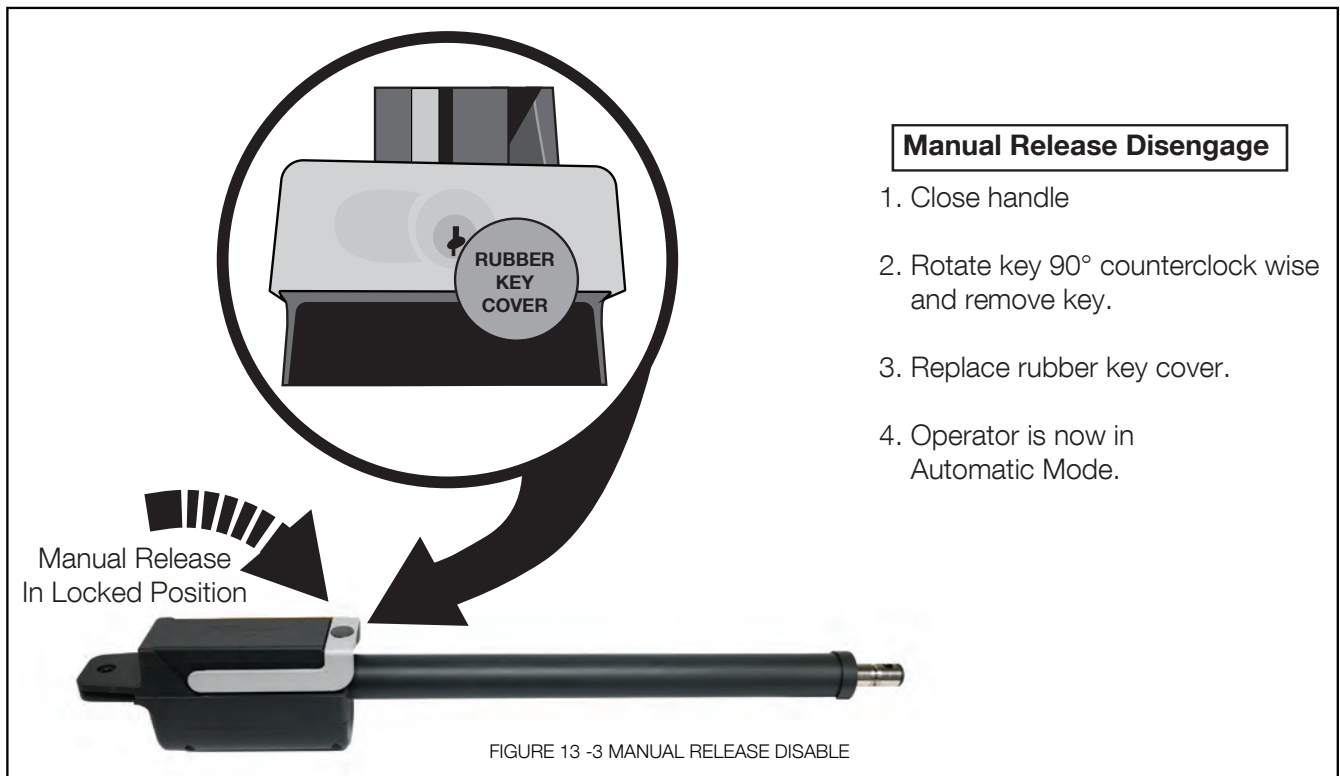
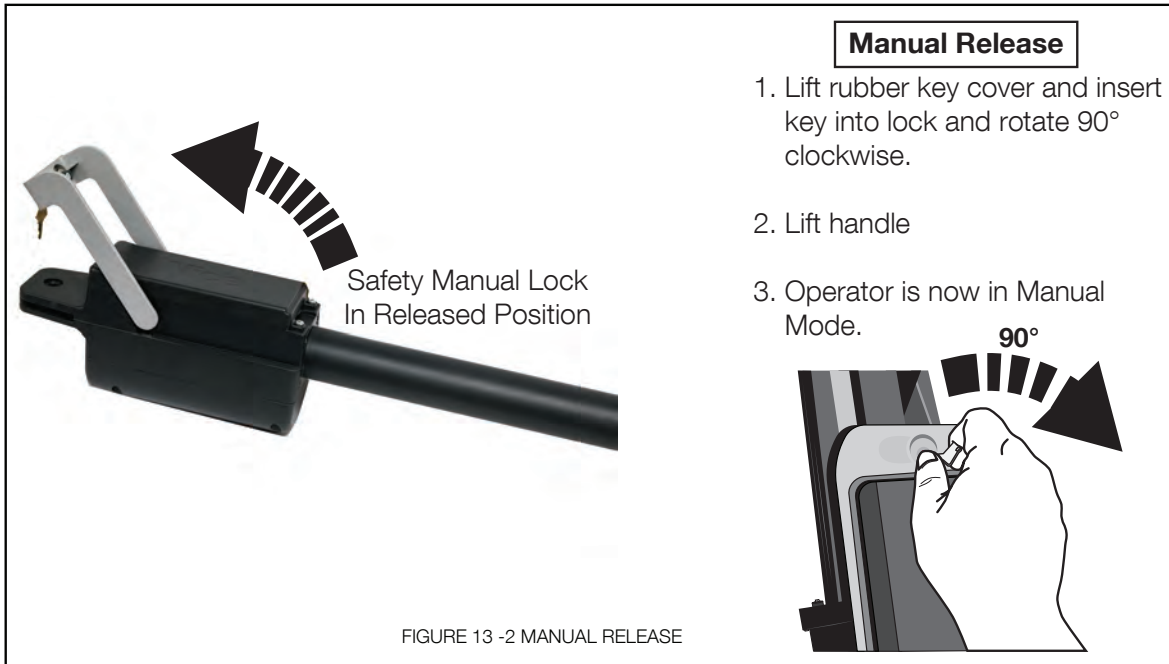
ES096100

**Moving Gate can cause Serious Injury or Death.**

Persons are to keep clear! The gate is able to be moved without prior warning.  
Do not allow children to operate gate or play in gate area.  
This entrance is for vehicles only. Pedestrians must use separate entrance.  
Persons are to read the owner's manual and safety instructions.

**Le portail en mouvement peut causer des blessures graves ou la mort.**

Les personnes ne doivent pas s'approcher!  
Le portail est capable d'être bougé sans avertissement préalable.  
Ne pas laisser les enfants utiliser le portail ou jouer dans le domaine du portail.  
Cette entrée est réservée aux véhicules.  
Les piétons devront utiliser une entrée séparée.  
L'utilisateur doit lire le manuel d'utilisation et les instructions de sécurité.



## 15 - 1050 PROGRAMMING

### 15.1 - FORCE

**Static:** Set sensitivity to constant force on a scale of 1 to 10 (1 being the most sensitive).

**Dynamic:** Set sensitivity of sudden impact force to the moving gate on a scale of 1 to 10 (1 being most sensitive).

**ESC:** Exit the FORCE menu.

### 15.2 - SPEED

**Max:** Sets the limit of maximum allowed gate speed on a scale of 20% to 100% (20% being the lowest setting).

**Standard:** Sets the limit of the gate speed during normal movement (not stop/start) on a scale of 20% to MAX (20% being the lowest setting).

**Low:** Sets the limit of the gate speed while in LEARNING mode and when moving in SLOW, on a scale of 20% to 100% (20% being the lowest setting).

**Slowdown:** Set gate speed when going into approaching the open or close limits on a scale of 20% to 100% (20% being the lowest setting).

### 15.3 - ACCELERATION

**Max:** Sets the limit of gate acceleration when reversing the gate after an obstacle has been detected by the UL/Edge or current sense feature (Force). Settings from 3 to 10, with 10 being the highest rate of gate acceleration. \*

**Standard:** Sets the limit of the gate acceleration in normal operation. Settings from 1 to MAX, with MAX being the highest rate of gate acceleration. \* \*TO PREVENT DAMAGE TO THE GATE OR THE CONTROLLER USE LOWER ACCELERATION SETTINGS FOR HEAVIER GATES.

**ESC:** Exit the SPEED menu.

### 15.4 - DELAY

**Auto Close:** Sets the timeout before the gate closes automatically from the fully open position. Settings from 0 (off) to 90 seconds. Setting this to 0 will disable the auto close timer.

**Slave:** Sets the delay for opening the slave gate leaf in a Master/Slave (Motor 1 and Motor 2 operation), (dual gate) system. Settings from 0 to 5 seconds with a step of 0.5 seconds.

**Lamp/Strobe:** Sets the amount of time the Lamp accessory output is activated prior to gate movement. Settings from 0 to 5 seconds with a step of 0.5 seconds.

**Lock:** Sets the amount of time the Magnetic Lock accessory output is activated to disable the lock when opening the gate. Settings from 0 to 5 seconds with a step of 0.5 seconds.

**Run Time:** Sets the maximum run time for the gate. Used in case the gate doesn't reach its limits. Settings from 15 to 120 seconds with a step of 1 second.

**ESC:** Exit the DELAY menu.

### 15.5 - FUNCTION

**Learn:** Puts the gate operator into learning mode for a Swing or Slide gate, and Blue BUS peripherals. Learning mode for a Swing or Slide style gate involves selecting the gate type (Light, Average, Heavy), then fully opening and closing the gate to sense the limits. Selecting the gate type selects pre-calculated values for the FORCE, SPEED, and ACCELERATION settings. Learning the Blue BUS peripherals enables the gate operator to discover and integrate accessory devices like Blue BUS access control and safety devices.

**Positions:** Configures the points in the gate open, close, and partial cycles at which deceleration occurs.

- Slow Down – Open: Sets the point in the % of gate opening when the gate begins deceleration to the fully open position.

- Slow Down – Close: Sets the % of gate opening when the gate begins deceleration to the fully close position.
- Partial: Sets the point in the % of gate opening when the gate begins when given a PARTIAL command.

**Auxiliary Inputs:** Auxiliary inputs IN AUX1 (16) and IN AUX2 (18) can be programmed with one of the following options:

- No program No Function used
- OPEN the Gate
- CLOSE the Gate
- STEP Cycling Step (Open-Stop-Close-Stop)
- PARTIAL opening
- PARTIAL 1 Partial Opening 1 (open one leaf in dual gate applications)
- STOP the gate and Auto-closing
- HOLD TO OPEN Input must be maintain active for Opening
- HOLD TO CLOSE Input must be maintain active for Closing
- FIRE Reset Hard Shut Down and Open the Gate
- TIMER 1 Start Count Down TIMER1
- TIMER 2 Start Count Down TIMER2
- PHOTO Photocell PHOTO input: reverse to opening when closing
- PHOTO1 Photocell PHOTO1 input: Stop Gate when activated
- PHOTO2 Photocell PHOTO2 input: reverse to closing when opening
- SHADOW Loop input: prevent closing gate when completely open
- LOCK system from other command (only STEP H overrides the lock)
- UNLOCK Unlock the system if locked
- OPEN and LOCK Open the Gate and inhibit further commands (except STEP H)
- CLOSE and LOCK Close the Gate and inhibit further commands (except STEP H)
- OPEN and UNLOCK Open the Gate and un-inhibit further commands
- CLOSE and UNLOCK Close the Gate and un-inhibit further commands
- STEP H Command high priority Step cycling (open-stop-close-stop)

**Auxiliary Outputs:** Auxiliary outputs OUT AUX1 (1,2,3,) and OUT AUX2 (4,5,6,) can be programmed with one of the following options:

- NO PROGRAM Output not used
- OPEN Output is activated when Gate is open
- CLOSE Output is activated when Gate is closed
- MOVING Output is activated when Gate is moving
- TIMER 1 Output is activated when TIMER1 is counting down
- TIMER 2 Output is activated when TIMER2 is counting down

**Radio Channel:** For the Plug-in On board Receiver, 15 radio channels may be programmed with one of the following options:

- NO PROGRAM
- OPEN (Default CH. 2)
- CLOSE
- STEP (Default CH. 1)
- PARTIAL
- PARTIAL 1
- STOP
- HOLD TO OPEN
- HOLD TO CLOSE
- TIMER 1
- TIMER 2
- PHOTO
- LOCK
- UNLOCK
- OPEN and LOCK
- CLOSE and LOCK
- OPEN and UNLOCK
- CLOSE and UNLOCK
- STEP H
- TOGGLE & LATCH

**Timers:** Set time for count down timers Timer 1 and Timer 2. Settings between 1 second and 9 hours in 1 second increments.

**Events:** Up to 8 weekly events (EV1 through EV8) can be programmed and stored. Each event can be programmed to trigger at a specific time and can

be assigned to any combination of days of the week (Monday through Sunday). Events that are already programmed into the system may be suspended temporarily, or removed permanently from memory. The following actions can be assigned to events:

- No program
- Open
- Close
- Partial
- Partial 1
- AxOut1 On
- AxOut1 Off
- AxOut2 On
- AxOut2 Off
- Open and Lock
- Close and Lock
- Open and Unlock
- Close and Unlock
- Timer 1
- Timer 2

**To program weekly events EV1 through EV8, perform the following steps:**

1. Press FUNCTION -> Events.
2. Press and hold OK to display EV1 (display will blink "EV1").
3. Press UP or DOWN to toggle between events, then press OK to make a selection. The display changes to hours.
4. Press UP or DOWN to toggle between hours, then press OK to make a selection. The display changes to minutes.
5. Press UP or DOWN to toggle between minutes, then press OK to make a selection. The display changes to individual days of the week.
6. Press UP or DOWN to toggle between days of the week. Press OK to toggle between ON and OFF for each day of the week. Continue toggling through the days of the week until ESC is displayed. Press OK to advance to the next event.
7. Repeat step 2 through 6 for event EV2 through EV8.

**To temporarily suspend one or more weekly events (EV1 through EV8), perform the following steps:**

1. Press FUNCTION -> Events.
2. Press OK quickly to display EV1 active days.
3. Press OK quickly again to display "Suspend". Event EV1 is now suspended and will not run until re-enabled.
4. Press UP or DOWN to toggle through the events EV1 – EV8 and repeat steps 2 through 3 to suspend or enable other weekly events.

**Charger:** A battery charger is built-in with the Control board for use with a backup battery. The charger may be manually programmed for customized charge settings or set to "Auto" to provide a battery charging profile that automatically compensates for temperature and current during the charging process. The following parameters are available for programming the battery charger:

- Charger On/Off
- Select Max current for charging (from 0.1A to 1.5A step 0.05A)
- Cycling Time (1 second off charging every cycling time)
- Auto (best charge considering temperature)

**Standby:** Programs the timeout for the gate operator to go into low power standby mode. Low power standby is Settings from 5 to 120 seconds, or may be disabled with "OFF". During low power standby there is no data displayed on the gate operator LCD and it consumes a minimum amount of power to extend the life of the backup battery. All the outputs are switched off and the LED OK blinks to show this standby status of the system.

**Advance Settings:** The following settings are available for customizing the gate operator as required by the customer's installation requirements:

- Set Language (English Spanish French)
- Set clock 12H/24H
- Set LCD Contrast
- Direction Motor (Changes main motor direction) (Can only be performed in learn mode)
- Auto Close Option (Allows auto close timer to close from any open position)
- Exit Option (Disables free exit input when partially open)

- Set Anti-tailgate (Closes gate immediately after vehicle has cleared safety sensors)
- Select inputs LOOP or PHOTO
- Select UL/EDGE input type (NO, NC, Analog)
- Select Master / Slave Motor1 or Motor2
- Activate link for remote Master/Slave (Enables control of an additional gate operator board)
- Power Fail Open (Opens gate automatically on batter backup power if main AC power input loss is detected)
- Motor 12V (Forces motor control voltage to +12VDC even if the supply voltage varies from +9.5VDC up to +35VDC)
- Set Virtual Encoder (Used for motors without built-in encoders)

**Default:** This setting gives the installer/user the option of returning some or all settings of the gate operator to the original factory settings:

- System settings
- Radio Channel settings
- Event settings
- Charger settings

**ESC:** Exit the FUNCTION menu.

## 15.6 - DISPLAY

**ESC:** Exit the DISPLAY menu.

**Info:** Displays the manufacturer name, product name/model, software versions, and serial number.

**Clock:** Displays the calendar date and time in the real time clock. Pressing and holding the "OK" button for 5 seconds enables the date and time settings to be updated manually.

**Main Volt:** Displays the gate operator main control voltage in volts DC.

**Battery Volt:** Displays the gate operator backup battery voltage in volts DC.

**Sun Volt:** Displays the solar panel input voltage in volts DC.

**Motor Volt:** Displays the voltage at the motor in volts DC.

**UL Volt:** Displays the voltage at the UL/Edge sensor input in volts DC.

**Temperature:** Displays the temperature of the gate controller board in degrees Centigrade or Fahrenheit (press OK and hold 5 seconds to change scale).

**Service:** The following information is recorded and viewable about the operating history of the gate:

- Total: Displays the total number of open-close cycles (non- Settings ).
- Partial: Display the total number of partial cycles. Reset by pressing the "OK" button for several seconds.
- Maint. Display the number of cycles before service is required. Settings from 1000 to 50000 cycles in increments of 1000 cycles.

**Motor:** Displays the Motor position, voltage, and current.

**Motor 1:** Displays the Motor1 position, voltage, and current.

**Motor 2:** Displays the Motor2 position, voltage, and current.

**Charger:** Displays the battery charger voltage and current.

**Last Reset:** Displays the code for diagnostic review. Used for diagnostic and troubleshooting.

**ESC:** Exit the DISPLAY menu.



## 16 - EMERGENCY VEHICLE ACCESS

- 16.1** The automatic vehicular gate system must be designed to allow access to emergency vehicles under different operating conditions.
- 16.2** During normal powered operation, emergency vehicles access the gate by use of the emergency vehicle access device installed on your gate system. The type of device that is used in your community is dependent on your city codes. These devices may include (but are not limited to) Fire Department lock boxes, Click-2-Enter radio receivers, strobe light sensors, siren sensors, etc.
- 16.3** Check with your installer to determine if your gate system is equipped with a back-up power system. In the event of a primary (AC) power failure and a back-up system (DC) power failure (low charged or dead batteries for example), the system must have a release system to allow the gate to be manually operated. The release device must be accessible from either side of the gate and must be present so that emergency personnel can gain access through the gate under this condition.
- 16.4** If applicable, this system is equipped with a manual release system that will allow the gate to be pushed open in the event of a power outage or equipment failure.
- 16.5** NOTE: Never attempt to manually push open any gate with an operator attached to it until you have verified that power to the operator has been shut-off.
- 16.6** The automatic vehicular gate system must be designed to allow access to emergency vehicles under different operating conditions.
- 16.7** In the event of a power failure, the emergency vehicle access device may not be functional because the gate operator is not powered. NOTE: DC powered back-up systems are optional and your gate system may or may not be equipped with one. Check with your installer to determine if your gate system is equipped with a back-up power system.
- 16.8** For manual fail-safe gate operation, turn power to the operator OFF. If a backup power system is in use, be sure that this power is turned OFF also or disconnected. Once power is OFF, the gate can be manually operated, by disconnecting the gate attachment bracket (816).

## 17 - GLOSSARY

**LOCK-** Ceases all operator function except HIGH PRIORITY inputs.

**COMMERCIAL / GENERAL ACCESS VEHICULAR GATE OPERATOR-CLASS II** - A vehicular gate operator (or system) intended for use in a commercial location or building such as a multi-family housing unit (five or more single family units), hotels, garages, retail store, or other building servicing the general public.

**ENTRAPMENT** - The condition when an object is caught or held in a position that increases the risk of injury.

**FORCE STATIC** - Constant load threshold for sensitivity setting.

**FORCE DYNAMIC** - Impact sensitivity setting.

**GATE** - A moving barrier such as a swinging, sliding, raising, lowering, or the like, barrier, that is a stand-alone passage barrier or is that portion of a wall or fence system that controls entrance and/or egress by persons or vehicles and completes the perimeter of a defined area.

**(STEP H) HIGH PRIORITY** - Step by step control.

**INHERENT ENTRAPMENT SENSOR SYSTEM** - An automatic sensor system which senses entrapment of a solid object and is incorporated as a permanent and integral part of the operator.

**INDUSTRIAL / LIMITED ACCESS VEHICULAR GATE OPERATOR-CLASS III** - A vehicular gate operator (or system) intended for use in an industrial location or building such as a factory or loading dock area or other locations not intended to service the general public.

**RESTRICTED ACCESS VEHICULAR GATE OPERATOR-CLASS IV** - A vehicular gate operator (or system) intended for use in a guarded industrial location or building such as an airport security area or other restricted access locations not servicing the general public, in which unauthorized access is prevented via supervision by security personnel.

**RESIDENTIAL VEHICULAR GATE OPERATOR-CLASS I** - A vehicular gate operator (or system) intended for use in a home of one-to four single family dwelling, or garage or parking area associated therewith.

**STEP BY STEP** - Command that opens-stops-closes-stops the gate with each press of the button.

**SYSTEM** - In the context of these requirements, a system refers to a group of interacting devices intended to perform a common function.

**UNLOCK** - Resumes normal operation after a blocked condition.

**WIRED CONTROL** - A control implemented in a form of fixed physical interconnections between the control, the associated devices, and an operator to perform predetermined functions in response to input signals.

**WIRELESS CONTROL** - A control implemented in means other than fixed physical interconnections (such as radio waves or infrared beams) between the control, the associated devices, and an operator to perform predetermined functions in response to input signals.

### Contact us

Nice Group USA Inc.  
12625 Wetmore Road Suite 218  
San Antonio, TX 78247  
Ph. +1.210.545.2900  
Fax +1.210.545.2915

[www.niceapollo.com](http://www.niceapollo.com)  
[www.facebook.com/NiceApollo](https://www.facebook.com/NiceApollo)

