

# SlideDriver™ II

SlideDriver II

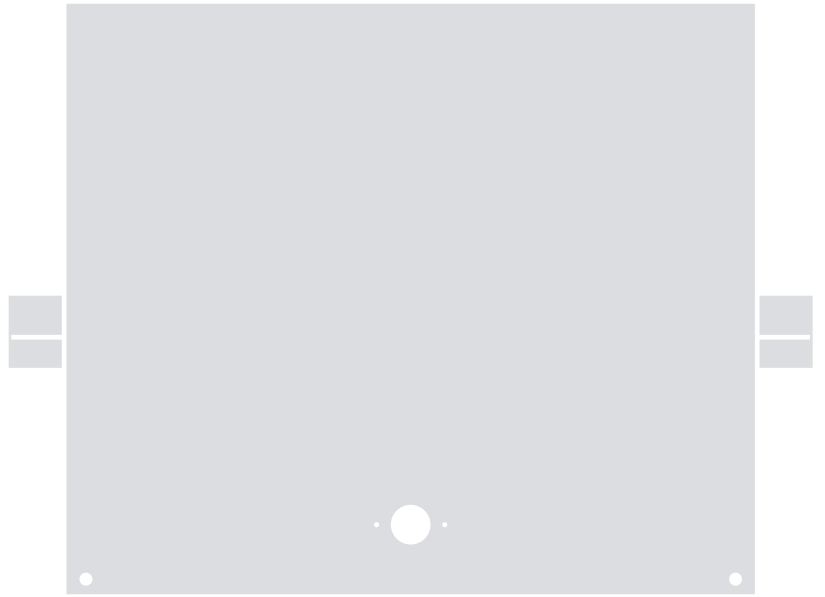

**Slide gate operator**

EN - Digital installation manual

# TABLE OF CONTENTS

---

## SlideDriver II All Models

Table of Contents.....	2	List of Entrapment Sensors .....	57
Safety Requirements.....	3-9	Approved Sensor Wiring.....	58-61
Features .....	10	Entrapment Sensor Response .....	62-63
Components .....	11-14	IES Sensitivity and Wind Load Factor .....	64
Plan Site Design .....	15	User Relay Outputs .....	66-70
Prepare an Installation Site .....	16-19	Relay Outputs - Basic.....	71
Install the Operator .....	20-21	Relay Outputs - Mechanical .....	72
Assemble, Align, and Install Drive Rail .....	22-24	Relay Outputs - Solid State .....	73
Install and Secure Limits .....	25-27	Loop Options .....	74-76
Flanged Drive Rail and Limit Flags.....	28	SmartTouch 720/725 - Hy5B Module.....	77
Wiring AC Power .....	29-30	SmartTouch 720/725 - Hy5B Loop Diagnostics .....	78-79
Wire Sizing and Runs .....	31-33	External Communications.....	80-83
Controller Connections .....	34	Connect to The Smart Installer App.....	84
User Interface .....	35	OXI Installation and Programming.....	85
Initial Setup.....	36-37	Firmware Updates and Debug Data .....	86
SD50F Emergency Fast Operate (EFO) ...	38	I/O Expansion Module Inputs .....	88-89
SmartTouch 720/725 Controller Menus .....	39	Diagnostics Menu .....	90
Operator Configurations .....	40-41	Clock and Timer.....	91-92
Operator Functions.....	42-43	Maintenance .....	93-98
Operator Communications.....	44-45	Additional Safety Information.....	99
Dual and Sequenced Gate Setup.....	46	Troubleshooting/Alerts/Faults/Errors .....	100-106
Vehicle Detector Loop Layouts.....	47	Appendix A - French Translations.....	107-110
Sequenced Gate: Loop View #1 .....	48	Appendix B - Accessory Instructions .....	111-126
Sequenced Gate: Loop View #2.....	49	Appendix C - Wiring Diagrams .....	127-135
Sequenced Gate: Loop View #3.....	50	SlideDriver II Installer Checklist.....	136-137
Sequenced Gate: Loop View #4.....	51	Warranty .....	138
Programmable Inputs .....	52-53	Specifications .....	139
Controller Inputs .....	54		
Entrapment Sensor Wiring - BlueBUS.....	55		
Entrapment Sensor Wiring .....	56		

## SAFETY MESSAGES

The safety messages below inform you about potential hazards that can result in injury. Safety messages specifically address level of exposure to operator and are preceded by one of four words: **DANGER**, **WARNING**, **CAUTION** or **NOTICE**.

 **DANGER**

Indicates a hazardous situation which, if not avoided, **WILL** result in **DEATH** or **SERIOUS INJURY**.

 **WARNING**

Indicates a hazardous situation which, if not avoided, **COULD** result in **DEATH** or **SERIOUS INJURY**.

 **CAUTION**



Indicates a hazardous situation which, if not avoided, **COULD** result in **MINOR** or **MODERATE INJURY**.

**NOTICE**

Addresses practices not related to personal injury. Indicates damage to equipment is probable if the hazardous situation is not avoided.

## COMMON INDUSTRIAL SYMBOLS

These international safety symbols may appear on product or in its literature to alert of potential personal injury hazards. Obey all safety messages that follow these symbols to avoid possible injury or death.

Symbol	Safety Hazard
	Attention - Take Notice
	Danger - Keep Away
	Entrapment Zone
	Possible Pinch Point

## IMPORTANT SAFETY INSTRUCTIONS

Hazards, associated with automatic gates, can be reduced with proper site design, installation, and use. Installers, maintenance crews, and owners/users must read and follow the safety requirements found in HySecurity® product manuals.



It is important that only qualified installers handle installation of HySecurity Gate vehicular gate operators. A “qualified” installer has one of the following:



1. A minimum of three years experience installing similar equipment.
2. Proof of attending a HySecurity Technical Training seminar within the past three years.
3. Significant manufacturer endorsements of technical aptitude in gate operator installation and operation.

Underwriter Laboratories (UL) and the American Society for Testing and Materials (ASTM) are responsible for current safety standards and regulations regarding gate operators and automated gates. All aspects of gate installation must comply with the appropriate safety standard. For the most up-to-date ASTM F2200 Gate and Fence Standards, refer to [www.astm.org](http://www.astm.org). For UL 325 Safety Standard, refer to [www.ul.com](http://www.ul.com). Consult local government agencies for up-to-date rules and regulations as certain municipalities have established licensing, codes or regulations that regulate automated gate system design and installation.

## GENERAL SAFETY INFORMATION

A gate operator is only a component in a gate system. The other parts of the gate system can include the gate, the external safety sensors, access controls, and vehicle detectors. To have a gate system that provides for safety, security, and reliable operation it is essential these components operate together as a system. It is the responsibility of the system designer and/or installer to ensure any safety or operational issues have been addressed.

# SAFETY REQUIREMENTS

## **WARNING**

To reduce the risk of injury or death:

1. READ AND FOLLOW ALL INSTRUCTIONS.
2. Never let children operate or play with gate controls. Keep the remote control away from children.
3. Always keep people and objects away from the gate. **NO ONE SHOULD CROSS THE PATH OF THE MOVING GATE.**
4. Test the gate operator monthly. The gate **MUST** reverse on contact with a rigid object or stop when an object activates the non-contact sensors. After adjusting the force or the limit of travel, retest the gate operator. Failure to adjust and retest the gate operator properly can increase the risk of injury or death.
5. Use the emergency release only when the gate is not moving.
6. **KEEP GATES PROPERLY MAINTAINED.** Read the user's manual. Have a qualified service person make repairs to gate hardware.
7. The entrance is for vehicles only. Pedestrians must use separate entrance.
8. **SAVE THESE INSTRUCTIONS.**

## **IDENTIFYING GATE OPERATOR CATEGORY AND UL 325 USAGE CLASS**

The UL 325 standard covers gate operators. Within this safety standard several Usage Classes are described that define different types of installations where gate operators can be applied. Some operators are restricted in their usage application. Appropriate Usage Classes are shown in the Specifications.

Class I



Class I: Intended for use in a location of one to four single family dwellings or a parking area associated with one to four single family dwellings.

Class II



Class II: Intended for use in a commercial location or building such as a multi-family housing units (five or more single family units) hotels, garages, retail stores or other buildings servicing general public.

Class III

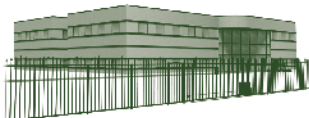

Class III: Intended for use in an industrial location or building such as factories or loading docks or other locations not accessible by the general public.

Class IV



Class IV: Intended for use in guarded industrial locations or buildings such as an airport security area or other restricted access location, not servicing general public, in which access is monitored by security personnel or via closed circuitry.



## VEHICULAR TRAFFIC ONLY



### WARNING

This automatic gate operator is not designed nor is it intended for pedestrian traffic. Vehicular gate operators must by their nature be powerful to function reliably. This power can cause injury or death. Accordingly, direct all pedestrian traffic to a separate walk-through gate.

#### Install this gate operator only when:

- The operator is appropriate for the construction of the gate and the Usage Class of the site.
- All openings of a horizontal slide gate are guarded or screened from the bottom of the gate to a minimum of 1.83 m (6 ft) above the ground to prevent a 57.2 mm (2-1/4 in) diameter sphere from passing through the openings anywhere in the gate, and in that portion of the adjacent fence that the gate covers in the open position.
- All exposed pinch points are eliminated or guarded.
- Guarding is supplied for exposed rollers.

The operator is intended for installation only on gates used for vehicles. Pedestrians must be supplied with a separate access opening. The pedestrian access opening shall be designed to promote pedestrian usage. Locate the gate such that persons will not come in contact with the vehicular gate during the entire path of travel of the vehicular gate.

The gate must be installed in a location so that enough clearance is supplied between the gate and adjacent structures when opening and closing to reduce the risk of entrapment. Swinging gates shall not open into public access areas.

The gate must be properly installed and work freely in both directions prior to the installation of the gate operator. Do not over-tighten the operator clutch or pressure relief valve to compensate for an improperly installed, improperly functioning, or damaged gate.

Permanently mounted controls intended for user activation must be located at least 1.83 m (6 ft) away from any moving part of the gate and where the user is prevented from reaching over, under, around or through the gate to operate the controls.

- Exception: Emergency access controls only accessible by authorized personnel (e.g. fire, police, EMS) may be placed at any location in the line-of-sight of the gate.

The Stop and/or Reset button must be located in the line-of-sight of the gate. Activation of the reset control shall not cause the operator to start.

A minimum of two (2) WARNING SIGNS shall be installed, in the area of the gate. Each placard is to be visible by persons located on the side of the gate on which the placard is installed.

#### For gate operators utilizing a non-contact sensor (Photo Eye):

- See instructions on the placement of non-contact sensors for each type of application.
- Care shall be exercised to reduce the risk of nuisance tripping, such as when a vehicle trips the sensor while the gate is still moving.
- One or more non-contact sensors shall be located where the risk of entrapment or obstruction exists, such as the perimeter reachable by a moving gate or barrier.

#### For a gate operator utilizing a contact sensor (Edge):

- One or more contact sensors shall be located where the risk of entrapment or obstruction exists, such as at the leading edge, trailing edge, and postmounted both inside and outside of a vehicular horizontal slide gate.
- A hardwired contact sensor shall be located and its wiring arranged so that the communication between the sensor and the gate operator is not subjected to mechanical damage.
- A wireless device that transmits radio frequency (RF) signals to the gate operator for entrapment protection functions shall be located where the transmission of the signals are not obstructed or impeded by building structures, natural landscaping or similar obstruction. A wireless device shall function under the intended end-use conditions.
- One or more contact sensors shall be located on the inside and outside leading edge of a swing gate. Additionally, if the bottom edge of a swing gate is greater than 152 mm (6 in) but less than 406 mm (16 in) above the ground at any point in its arc of travel, one or more contact sensors shall be located on the bottom edge.

## USE OF VEHICLE DETECTORS

Use of vehicle detectors (loop detectors) is strongly encouraged to prevent damage to vehicles caused by gates closing on them. This is not considered to be a safety item as most vehicle detectors cannot provide protection to pedestrians. In some situations, photoelectric devices may be used as vehicle detectors, but should be wired accordingly.

## GATE CONSTRUCTION AND SAFETY

Gate construction plays a very important role in ensuring the safety of any automated gate system. The standard for gate construction is ASTM F2200. Below are key areas to address in gate design for safety. For complete information consult the standard. Copies of the standard are available at: <https://www.astm.org/Standards/F2200.htm>.

# SAFETY REQUIREMENTS

---

Another source of information is available from DASMA, the Door and Access System Manufacturer's Association. The Association publishes Technical Data Sheets, one of which concerns ASTM F2200. For more information, see:

<http://www.dasma.com/PDF/Publications>

## General Requirements for gate construction:

- Gates shall be constructed in accordance with the provisions given for the appropriate gate type listed. Refer to ASTM F2200 for additional gate types.
- Gates shall be designed, constructed and installed to not fall over more than 45 degrees from the vertical plane, when a gate is detached from the supporting hardware.
- Gates shall have smooth bottom edges, with vertical bottom edged protrusions not exceeding 0.50 in (12.7 mm) other than the Exceptions listed ASTM F2200.
- The minimum height for barbed wire shall not be less than 6 ft (1.83 m) above grade. The minimum height for barbed tape shall not be less than 8 ft (2.44 m) above grade.
- An existing gate latch shall be disabled when a manually operated gate is retrofitted with a powered gate operator.
- A gate latch shall not be installed on an automatically operated gate.
- Protrusions shall not be permitted on any gate. Consult ASTM F2200 for exceptions.
- Gates shall be designed, constructed and installed such that their movement shall not be initiated by gravity when an automatic operator is disconnected.
- For pedestrian access in the vicinity of an automated vehicular gate, a separate pedestrian gate shall be provided. The pedestrian gate shall be installed in a location such that a pedestrian shall not come in contact with a moving vehicular access gate. A pedestrian gate shall not be incorporated into an automated vehicular gate panel.
- Any non-automated gate that is to be automated shall be upgraded to conform to the provisions of this specification.
- This specification shall not apply to gates generally used for pedestrian access and to vehicular gates not to be automated.
- Any existing automated gate, when the operator requires replacement, shall be upgraded to conform to the provisions of this specification in effect at that time.

## The following provisions shall apply to Class I, Class II, Class III, and Class IV vehicular horizontal slide gates:

All weight bearing exposed rollers 8 ft (2.44 m), or less, above grade shall be guarded or covered.

All openings shall be designed, guarded, or screened from the bottom of the gate to the top of the gate or a minimum of 72 inch (1.83 m) above grade, whichever is less, to prevent a 2-1/4 inch (57 mm) diameter sphere from passing through the openings anywhere in the gate, and in that portion of the adjacent fence that the gate covers in the open position. The gate panel shall include the entire section of the moving gate, including any back frame or counterbalance portion of the gate.

A gap, measured in the horizontal plane parallel to the roadway, between a fixed stationary object nearest the roadway (such as a gate support post) and the gate frame when the gate is in either the fully open position or the fully closed position, shall not exceed 2-1/4 inches (57 mm).

Exception: All other fixed stationary objects greater than 16 inches (406 mm) from the gate frame shall not be required to comply with this section.

Positive stops are provided to limit travel to the designed fully open and fully closed positions. These stops shall be installed at either the top of the gate, or at the bottom of the gate where such stops shall horizontally or vertically project no more than is required to perform their intended function.

All gates shall be designed with sufficient lateral stability to assure that the gate will enter a receiver guide. Consult ASTM F2200 for details on various gate panel types.

## EXTERNAL ENTRAPMENT PROTECTION SENSORS

Most HySecurity gate operators are equipped with a Type A, Inherent Entrapment Sensor (IES). UL 325 Safety Standard compliance requires installation of external entrapment protection sensors, the number of which, depends on entrapment hazards that exist at each particular installation.

To comply with UL 325, the following external sensors may be used:

- Contact sensors, such as edge sensors
- Non-contact sensors, such as photo eyes

Site designer or installer can choose either photo eyes, edge sensors, or a combination of these devices.

UL 325 Safety Standard for automatic sliding gates specifically requires that edge sensors, photo eyes, or a combination of both devices be installed to protect against pedestrian entrapment in BOTH directions of gate travel and wherever entrapment hazards exist.

**UL 325 LISTING:** Edge sensors and photo eyes must be tested and labeled as “Recognized Components” or otherwise certified to UL 325 requirements in order to be deemed acceptable for use in a gate operator. Study Important Safety Instructions and consider your specific installation to determine where greatest entrapment risks exist. Locate edge sensors and/or photo sensors accordingly. Be certain that a sufficient number of sensors are used so that pedestrians are protected from entrapment in both directions of gate travel and all hazard areas are fully protected. Most HySecurity gate operators require external entrapment sensors that utilize Normally Closed (NC) contact means of monitoring. HySecurity gate operators utilizing the SmartCNX Controller or the SmartTouch 720/725 Controller require external entrapment sensors that have a 10k Ohm or 4-wire pulsed monitoring scheme. Refer to UL website at [www.ul.com](http://www.ul.com) for most up-to-date list of gate operator safety standards (UL 325). Refer to [www.astm.org](http://www.astm.org) for a complete list of ASTM F2200 Gate and Fence Standards.



## Recommended External Entrapment Protection Sensors List

The following sensors have been tested with Nice | HySecurity gate operators by an independent laboratory and certified to comply with UL 325 7th Edition. Select sensors from this list for UL compliant gate automation solutions. Contact the sensor manufacturer for specific recommendations for use.

### UL 325 Standard:

- The operator shall monitor for the presence of every device at least once during each open and close cycle (32.1.8)
- It shall not be possible to make simple modifications in the field by adding, suppressing or changing, either on the operator or external entrapment protection device(s), to bypass, interfere with, or otherwise defeat the monitoring function. (32.1.10)
- Entrapment zones are now defined for each gate type (4.23, 4.24, 4.29, 4.34)

**Slide Gates:** To enable fully automatic operation, all SLIDE gate operators will require a minimum of TWO monitored external entrapment protection sensors (one for each direction) to protect entrapment zones in both the open and close direction of travel.

Preferred solution for slide gates: A photo eye for the close direction and a hard-wired edge sensor for the open direction that is mounted to the face of the leading post of the fence behind the gate. (Reach through injuries are the most common hazard associated with automatic sliding gates)

**Swing Gates:** To enable fully automatic operation, all SWING gate operators will require a minimum of ONE monitored external entrapment protection sensor to protect entrapment zones in either the open or close direction of travel. However, an additional monitored sensor is required if there is a risk of entrapment in both directions of gate travel.

Preferred solution for swing gates: A photo eye for the close direction and/or a hard-wired wraparound edge sensor on the leading edge of the gate, which protects for both directions of gate travel.

# SAFETY REQUIREMENTS

	Mfg. Part # or Model	Brand	Nice   Hysecurity Part #	Max Range	Smart Touch	Smart DC	SmartCNX / SmartTouch 725	1050	Mercury 310
<b>Photo Eyes (Retro-reflective)</b>	E3K-R10K4-NR-1	Omron	MX000999	40 ft	•	•	•		
	NIR-50-325	EMX	-	45 ft	•	•	•	•	•
	IRB-RET	EMX	-	53 ft	•	•	•	•	•
	E-931-S50RRGQ	Seco-Larm	-	46 ft	•	•	•		•
<b>Photo Eyes (Thru-Beam)</b>	Blue Bus Era Photo Eyes	Nice   HySecurity	EPMB/A EPMOB/A EPLOB/A EPMAB/A EMBORB/A	45 ft			•	•	•
	OVS-50TNR	Optex	-	33 ft	•	•			
	IRB-MON*	EMX	MX3990	65 ft	•	•	•		•
	E-960-D90GQ	Seco-Larm	-	90 ft	•	•	•		•
<b>Edge Sensors</b>	Sentir Series**	ASO Safety	"AS1502-" AS1501-"		•	•	•	•	•
	CPT210-2U-#-T2	Miller Edge	-		•	•	•	•	•
<b>Edge Sensor Converters</b>	Hy2NC (Converts 10K to NC Monitoring)	HySecurity	MX4018		•	•			
	GEM103 (Converts 10K to Pulsed Monitoring)	Miller Edge	-					•	
<b>Edge Wireless Kits</b>	iGAZE RE Kit	Transmitter Solutions	-		•	•	•	•	•
	WEL-200	EMX	-		•	•	•	•	•
<b>Multi-Input Module</b>	The Solution - MIM-62	Miller Edge	-		•	•	•		•

**Installers must assess each specific site and install sensors that protect all potential entrapment zones.**

For more information visit Safety or see latest operator manuals at [support.hysecurity.com](http://support.hysecurity.com)

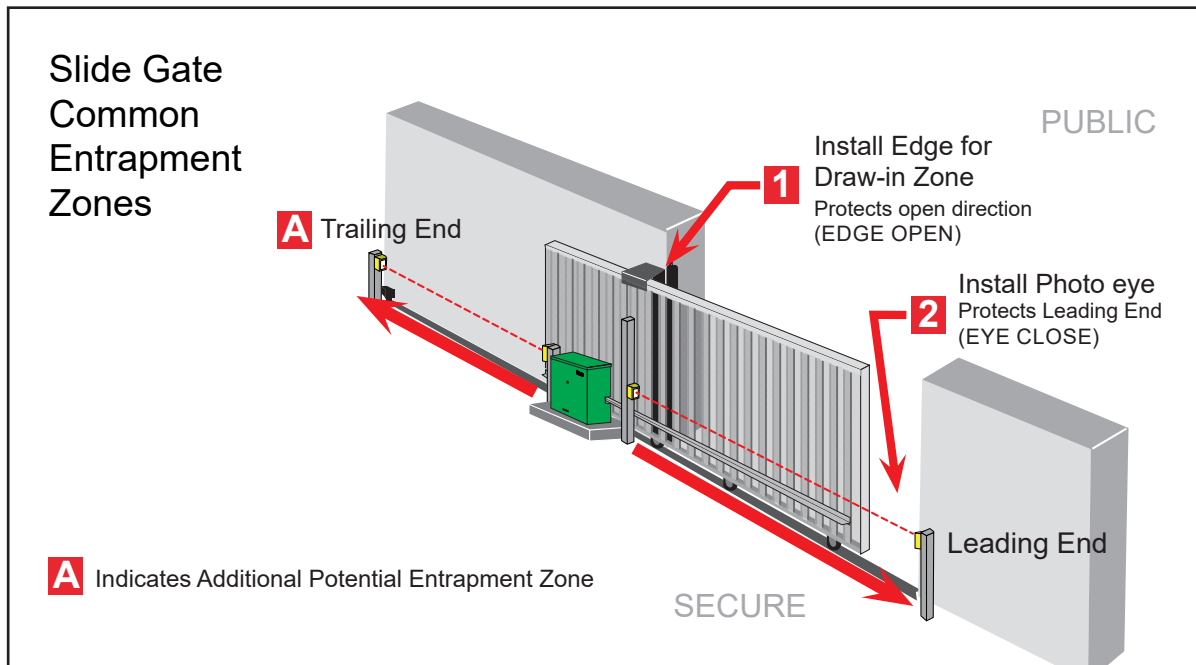

## STOP BUTTON

The stop button clears entrapment mode and resets some faults, errors, and alarms.

The external stop button for the SlideDriver II is located on the right side of the chassis.

Press the stop button while the gate is opening or closing to stop gate travel and disable the automatic close timer. The operator requires a new open or close command to resume function.

Inform all users of the location of the stop button and its function.

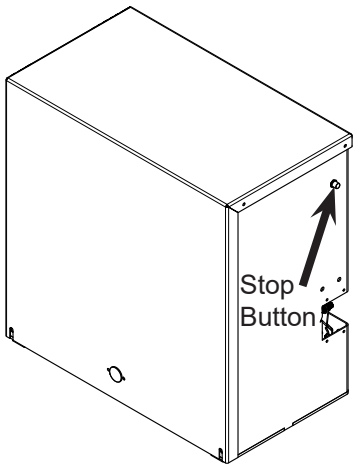

Figure 1. Stop Button

## EMERGENCY RELEASE

Teach all users how to turn off electric power, release the toggle handle, and manually move the gate.

**To manually move the gate:**

1. Remove the cover.

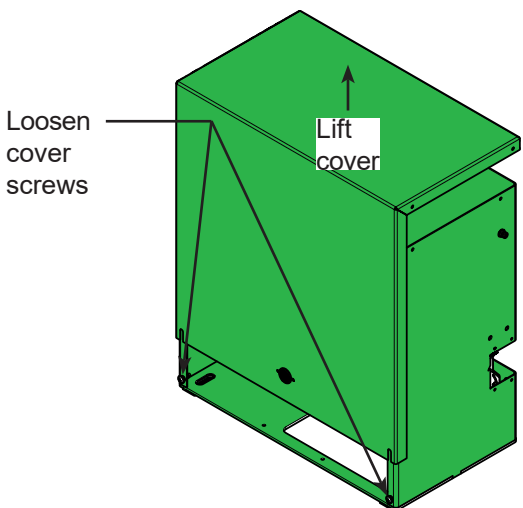

Figure 2. Cover Removal

2. Set the power switch to OFF.
3. Unclamp the toggle handle and secure it in the unclamped position.
4. Manually push the gate open or close.

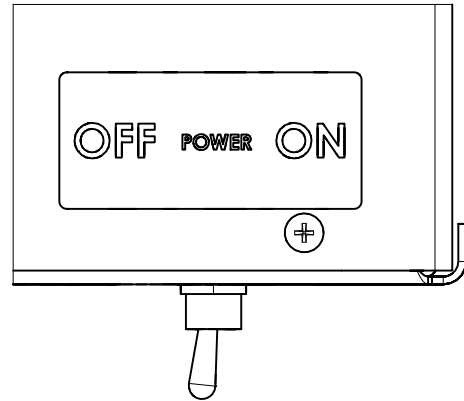

Figure 3. Power Switch Set to OFF

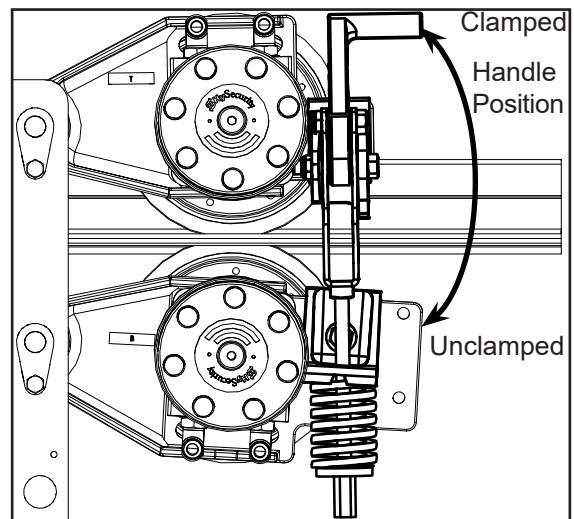

Figure 4. Slide the Gate Manually

## TO RETURN SLIDEDRIVER II TO AUTOMATIC OPERATION, FOLLOW THESE STEPS:

1. Clamp the toggle handle.
2. Set the power switch to ON.
3. Press STOP or RESET to clear any faults.
4. Attach the front cover.

### **⚠ WARNING**

When releasing the handle inside the chassis, be careful as the mechanism is spring-loaded and drops rapidly. Grasp the toggle handle firmly so your fingers do not get pinched, hit, or crushed.

# FEATURES

---

## INTELLIGENT FEATURES: SmartTouch™ 720/725 Controller

**Smart Installer App** for full control from your phone via Bluetooth.\*

**Save operator configurations** and troubleshoot system via installer smartphone app or USB.\*

**User Interface – The SmartTouch 720/725 Controller** manages 70+ configurable items in a simple menu driven interface. The controller includes a library of dozens of solutions for relay logic applications.

**Three configurable user relays** plus SmartTouch I/O Expansion module for 5 additional relay outputs on non-VFD models or (optional) 8 additional relay outputs on VFD models.

**OLED display** – A 32-character OLED provides increased readability for programming and troubleshooting.

**Intelligent Inherent Entrapment Sensor (IES)** - Any impediment to gate travel is sensed by the system, stopping gate movement per UL 325 Safety Standards. The intelligent system monitors gate power then adapts the IES to trip at an adjustable threshold above normal power.

**Hy5B™ 2.0 vehicle detector** – Four ports for HySecurity Hy5B 2.0 vehicle detectors, enabling advanced features like automatic gate compensation and loop diagnostics.

**Integrated HyNet™ technology** provides remote management capabilities over Ethernet: Securely report gate system status, vehicle tailgating, gate hits, failure to operate, and more, in real time to maintain perimeter security. Additionally, configure email alerts to communicate issues to installer, facility or security responders.\*

**Compatible with Nice accessories.** OXI receiver, ERA and INTI transmitters and BlueBUS photo eyes.\*

**Digital pressure gauge** stores peak pressure for past cycles in controller memory for easy troubleshooting.

**Solid state contactless limits** improve reliability and performance in blowing snow and freezing rain.

**VFD Speed Control** added to SD80V and SD200V models for lower mechanical stress on gates and longer service life.

\* Some features not available on SmartTouch 720.



SLIDEDRIVER II MAJOR PARTS DIAGRAM

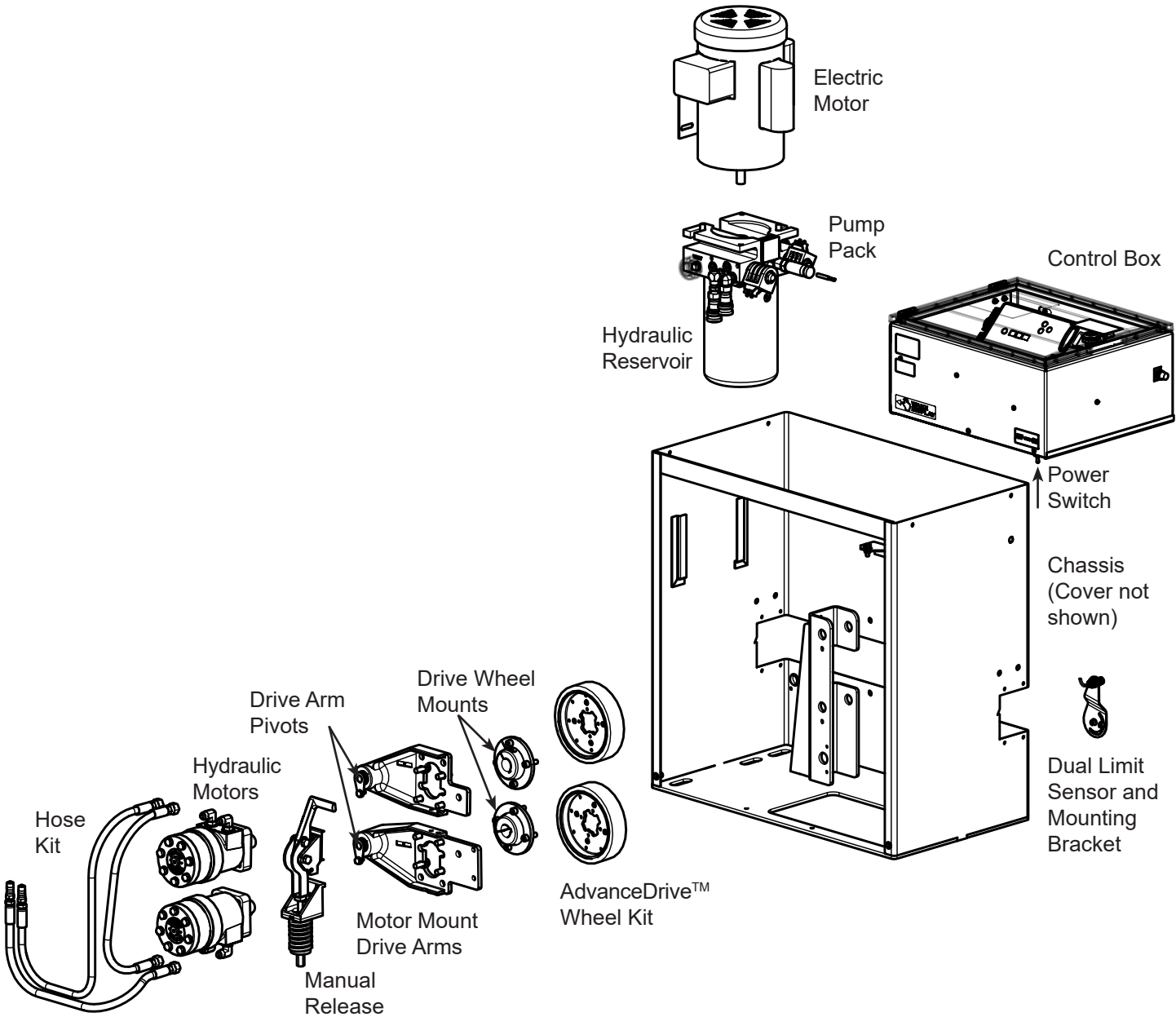



# COMPONENTS

## SLIDEDRIVER II 15, 40 AC MOTOR ELECTRICAL BOX

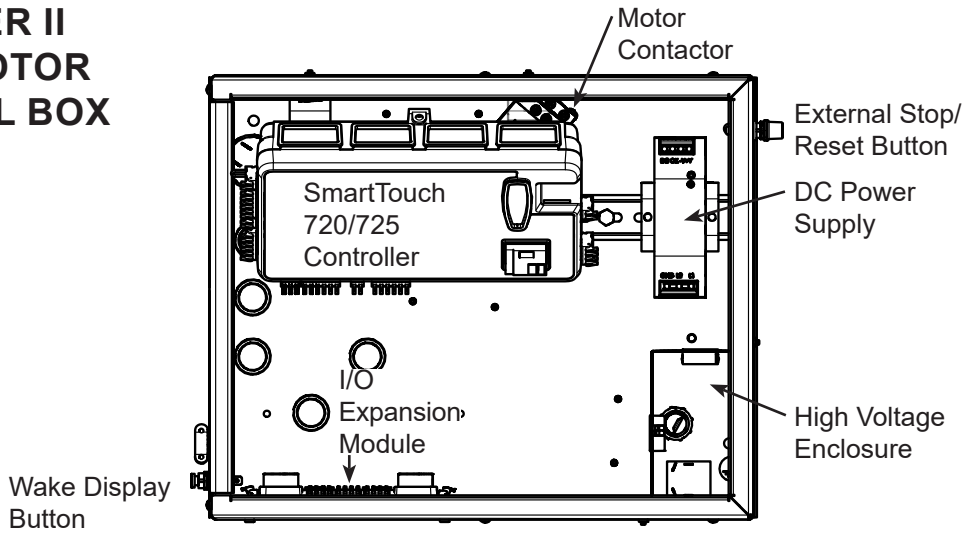

## SLIDEDRIVER II VFD (EXAMPLE) ELECTRICAL BOX

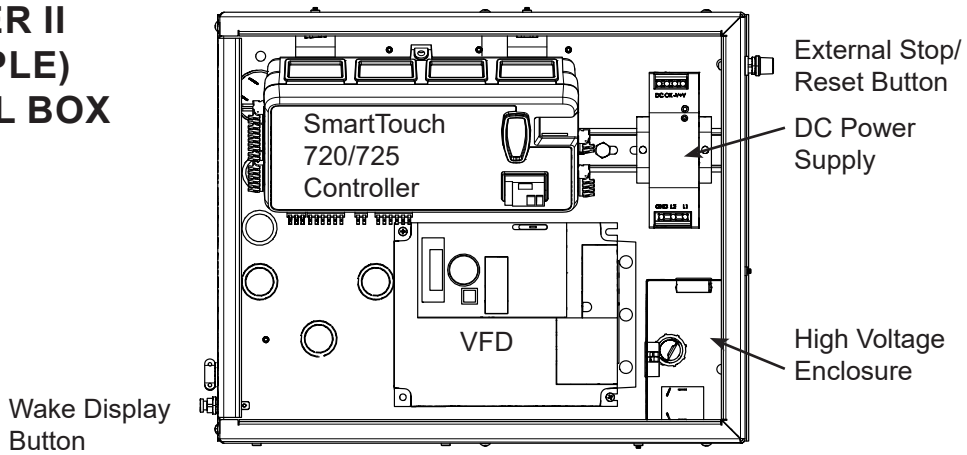

## SLIDEDRIVER II 200V DC EXTERNAL POWER ELECTRICAL BOX

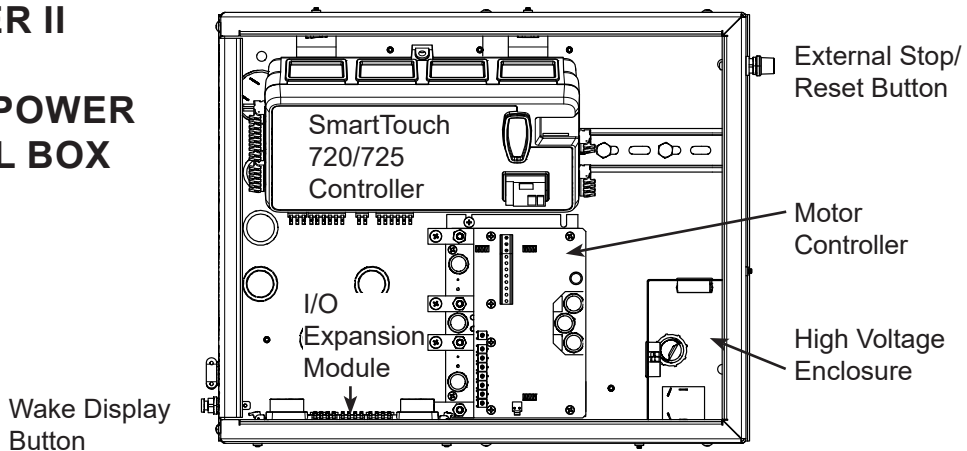

1Ø AC MOTOR

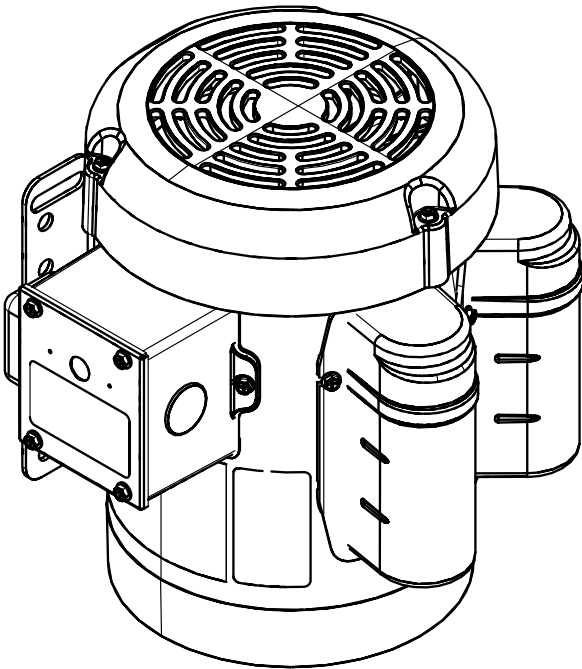

3Ø AC MOTOR

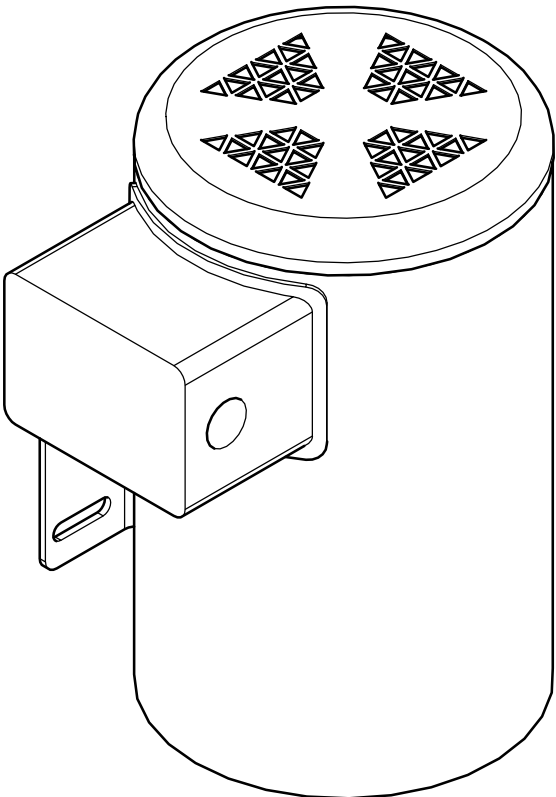

DC MOTOR

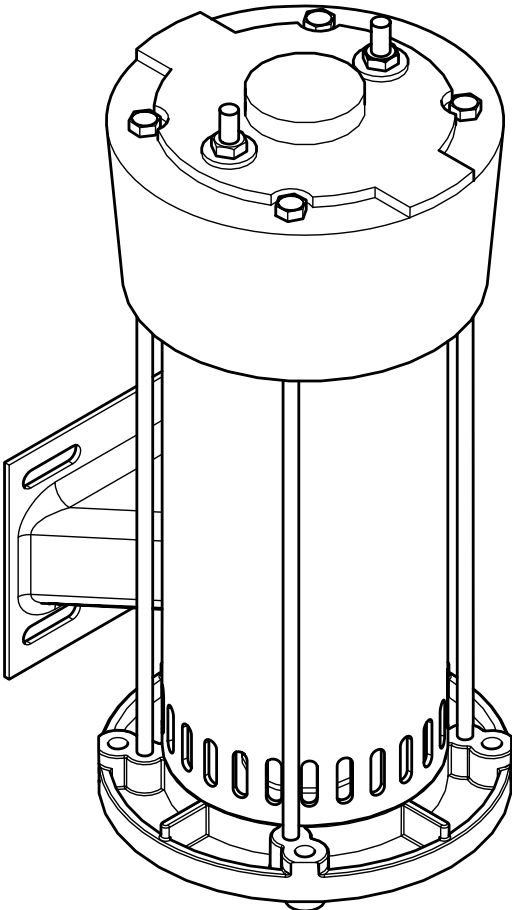

# COMPONENTS

## SD15 PUMP PACK

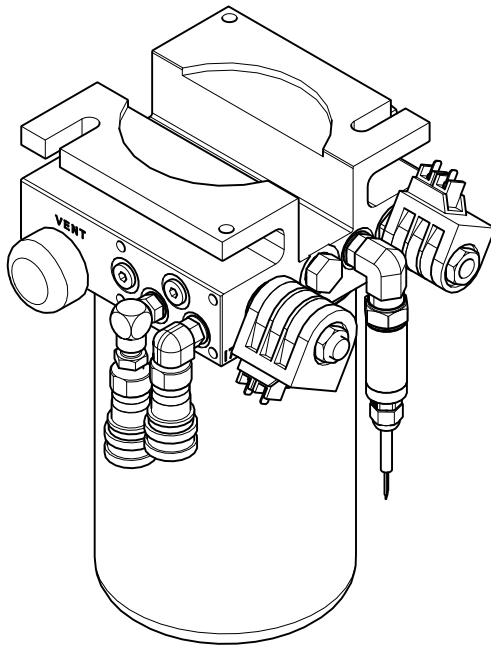

## SD40 PUMP PACK

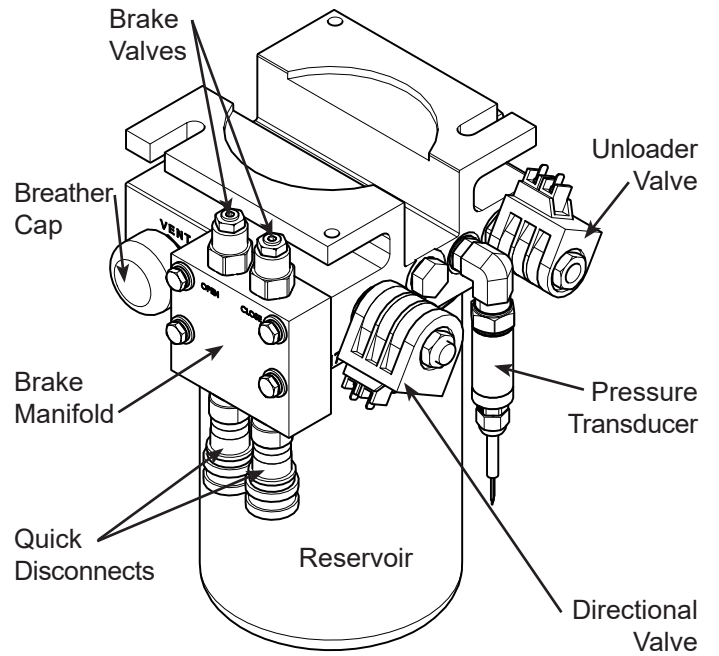

## SD50F, 80V, 200V PUMP PACK

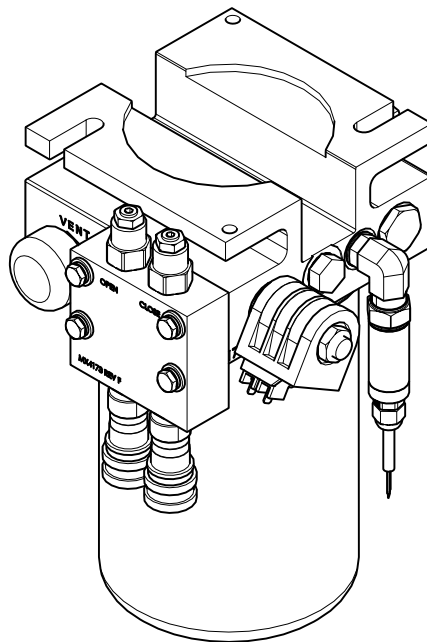

## WARNING

Be sure the WARNING signs are visible from either side of the gate in clear view of approaching vehicles. For your records, take a photograph of the completed installation site.

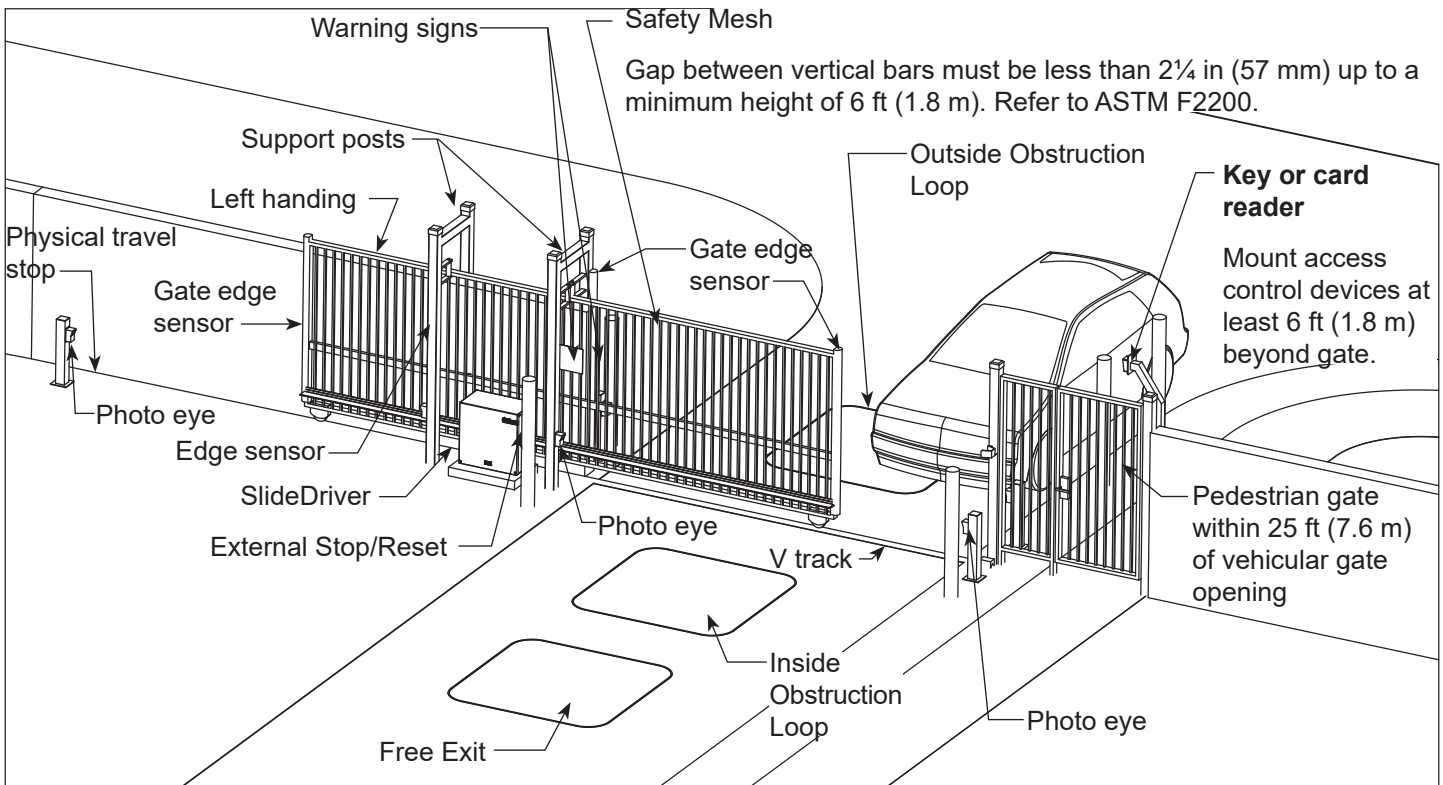

Example site for reference only. Follow UL325, ASTM F2200, and all local codes during planning and installation of gates and gate operators.

## Ship with kit contents:

- Quick Start Guide
- User Guide
- DASMA brochure
- Roll pins
- Wire ties
- Warning signs
- Limit flags (varies by model)
- Photo eye
- Edge sensor (except SD200V models)
- (200V only) Double sided tape
- (XtremeDrive only) Rack kit

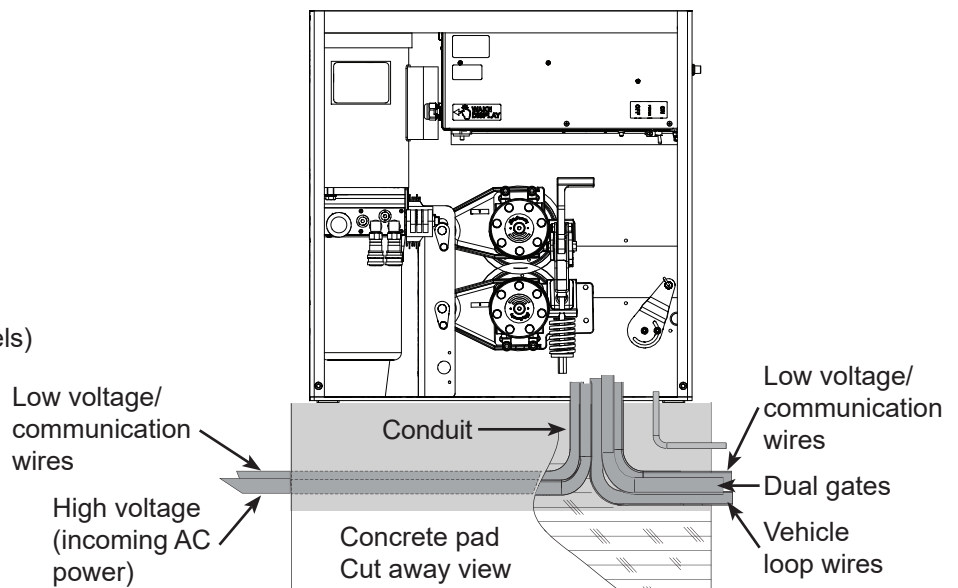

# PREPARE AN INSTALLATION SITE

Minimum conduit required	No.	Min. Size
AC Mains power (incoming)	1	1 in (25 mm)
Low voltage accessory wires	1	¾ in (20 mm)
Ground	1	¾ in (20 mm)
Loop wires	1	¾ in (20 mm)

Add'l conduit may be needed for:	No.	Min. Size
DC cables	1	2 in (50 mm)
Hydraulic hoses	1	2 in (50 mm)
Dual gate connection for low voltage wiring	1	1 in (25 mm)
Emergency release options	1	¾ in (20 mm)

**⚠ DANGER**

Know what's below! Many states subscribe to 811. Call the local utility number so underground utility lines can be marked before excavating.

**⚠ CAUTION**

If you cut, drill or alter the chassis, you may void the Warranty.

## SLIDEDRIVER SERIES TYPICAL

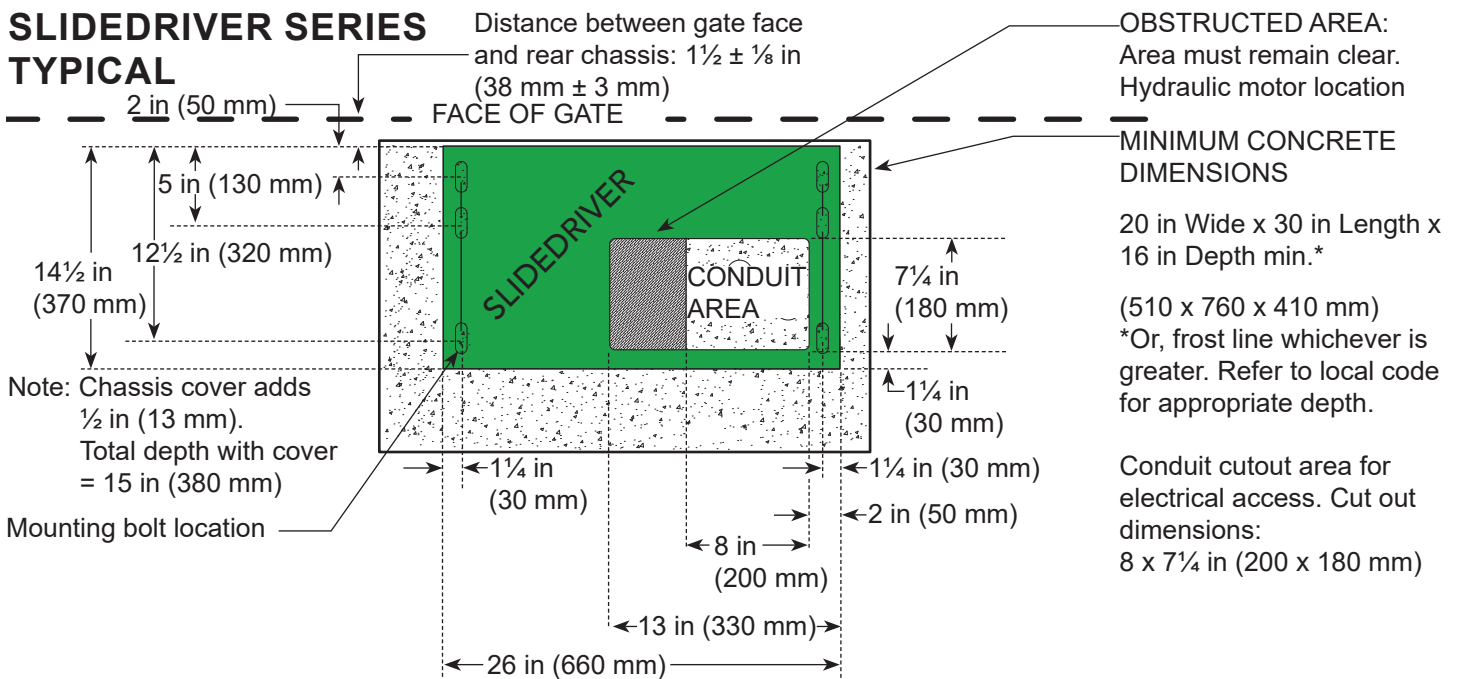

## SLIDEDRIVER 200 SERIES

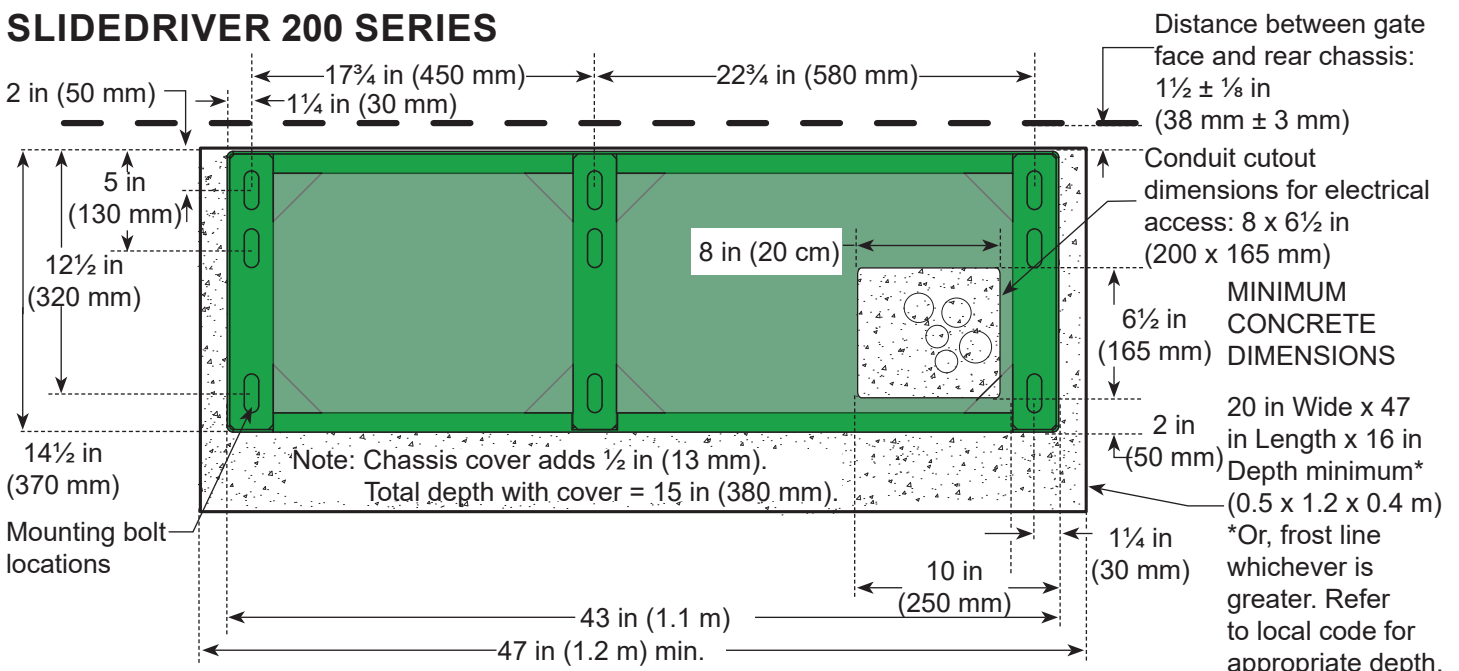

**NOTE:** Design shown for illustrative purposes only. Drawings are NOT TO SCALE.

# PREPARE AN INSTALLATION SITE

## CLEARANCES

### SlideDriver:

Side Access: Min. 24 in (0.6 m)

Front Access: Allow 30 in (0.8 m)

### Cabinet (Modular):

Front Access: Min. 36 in (0.9 m)

Rear Access: Allow 24 in (0.6 m)

### Cabinet (DC / UPS):

Door Swing: Min. 30 in (0.8 m)

Rear Access: Allow 24 in (0.6 m)

## NOTICE

Instructions and illustrations are for a right hand gate. For a left hand gate, mirror the orientation right to left.

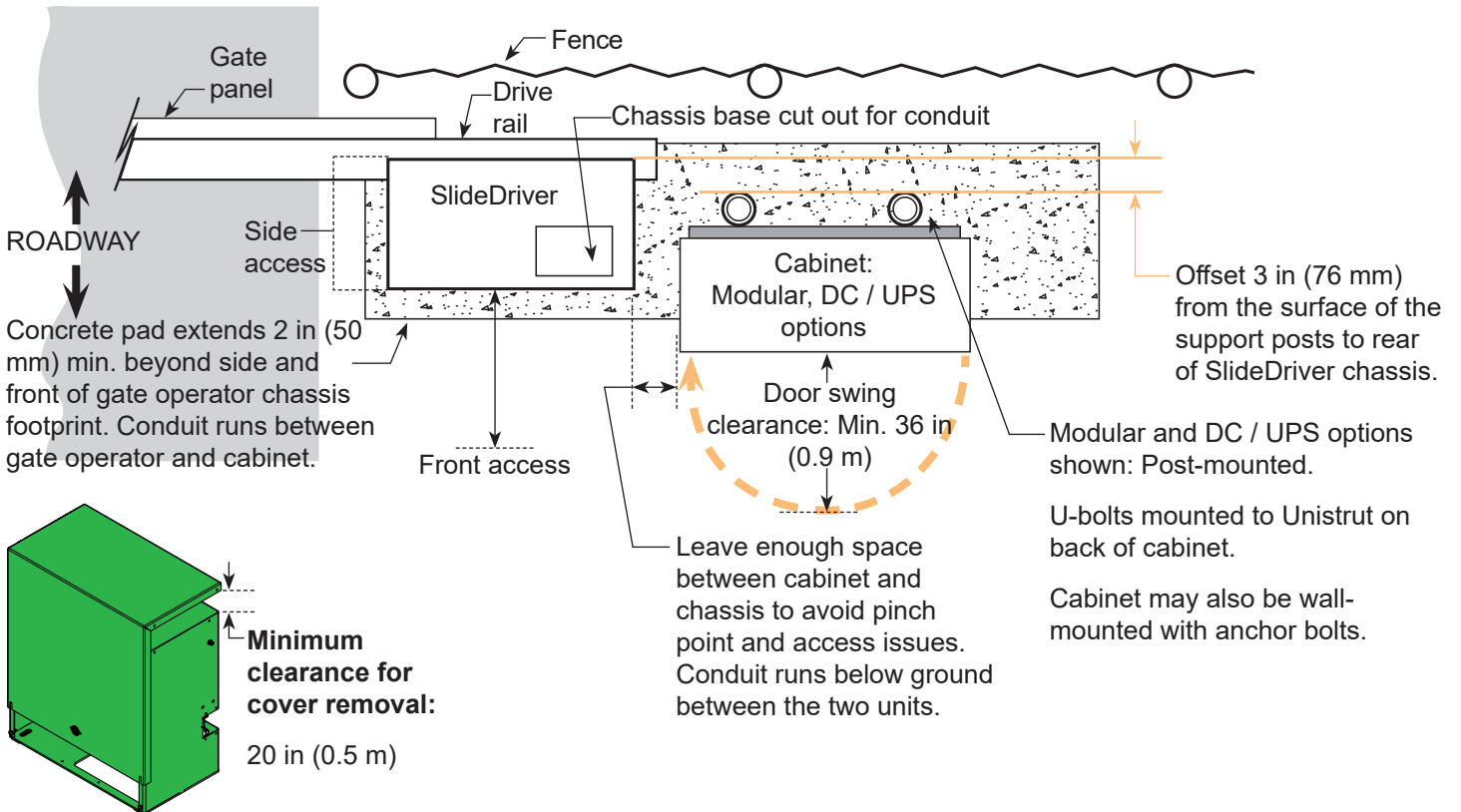

## OPERATOR AND GATE HANDING

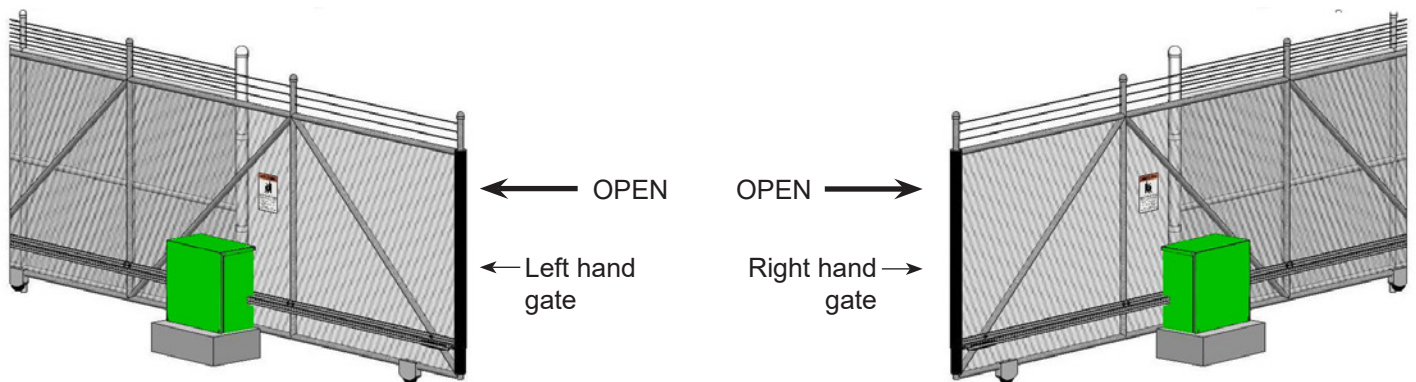

# PREPARE AN INSTALLATION SITE

## MARK THE ANCHOR BOLT LOCATIONS

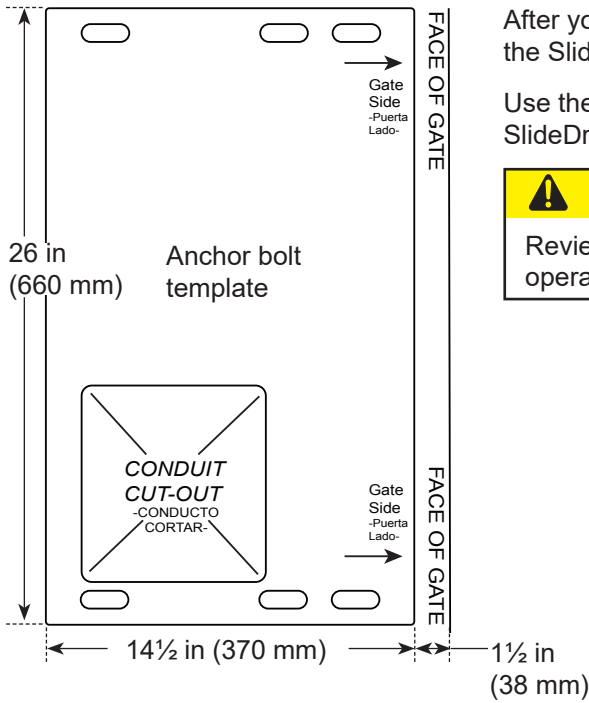

After you remove the operator, cut out the anchor bolt template on the side of the SlideDriver II box.

Use the template to mark the location of the anchor bolts that will secure the SlideDriver II to the concrete pad.

### **CAUTION**

Review the dimensions on page 16. Proper alignment of the SlideDriver II operator and the drive rail is critical.

## REPLACE THE VENT PLUG

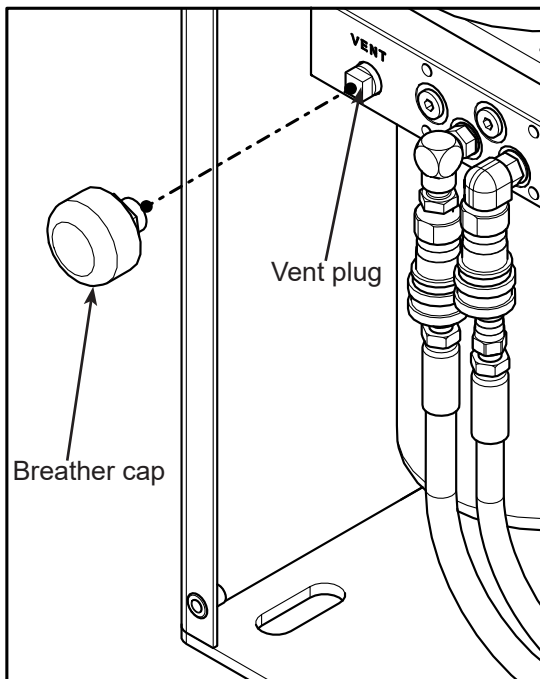

### **CAUTION**

Replace the vent plug with the breather cap before operating the SlideDriver II. Air pressure vents through the cap instead of through the pump seal and prevents rust by allowing condensation to evaporate. If you do not replace the vent plug with the breather cap, you will void the Warranty.

Drawings NOT to Scale



## EDGE SENSOR INSTALLATION

1. Attach channel segments to gate draw-in post.
2. Install one screw in the bottom channel segment.
3. Slide edge sensor into channel segments.

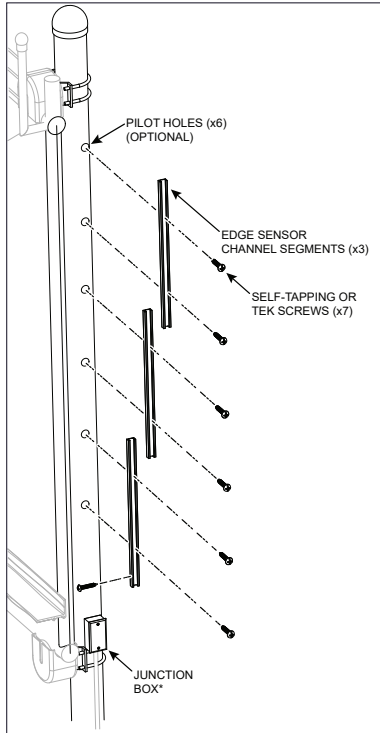

4. Connect edge sensor wires to conduit wires. Use a junction box to protect the splice.
5. Connect edge sensor to SmartTouch 720/725 Controller. See Digital Installation Manual for additional info.

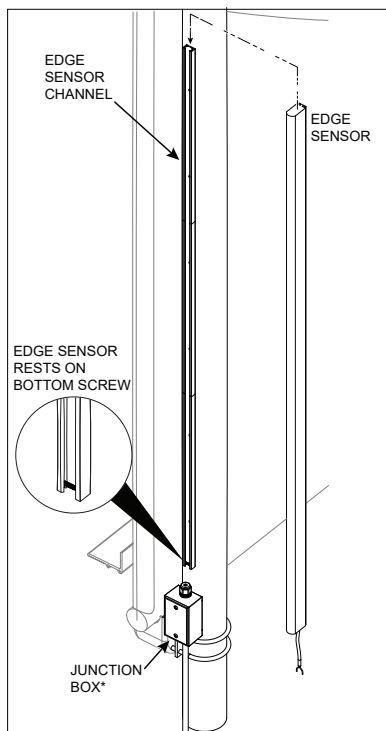
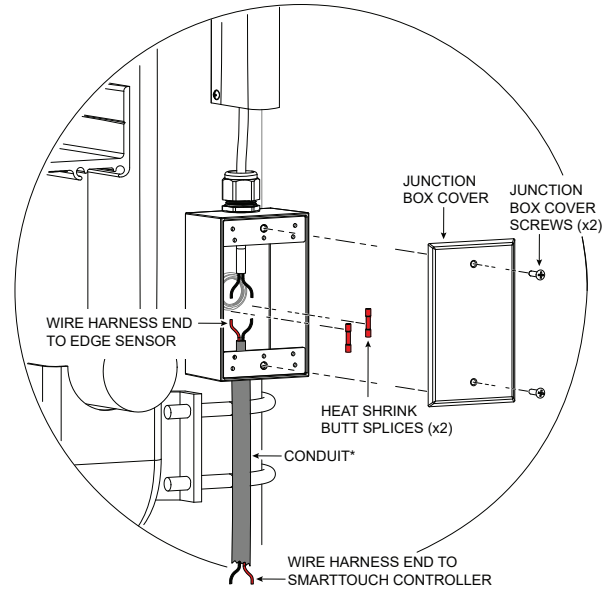

# INSTALL THE OPERATOR

## INSTALL THE CHASSIS

### **WARNING**

Obtain help before lifting or moving the operator. SlideDriver II models can weigh over 260 lbs (118 kg). Failure to comply may result in serious injury to personnel, damage to the equipment, or both.

1. Align the operator. Locate rear panel 1½ in from the face of vertical uprights.
2. Install concrete anchors (½ x 4 in min.). 2 anchor bolts required per cross support. 3 anchor bolts required per cross support for heavy gates (SD80V and SD200V).
3. Tighten the nuts, but leave room for adjustments.
4. Level the operator. Shim with a corrosion resistant material such as aluminum or plastic.

### **CAUTION**

Do NOT fully tighten the anchor bolts until after the drive rail is installed.

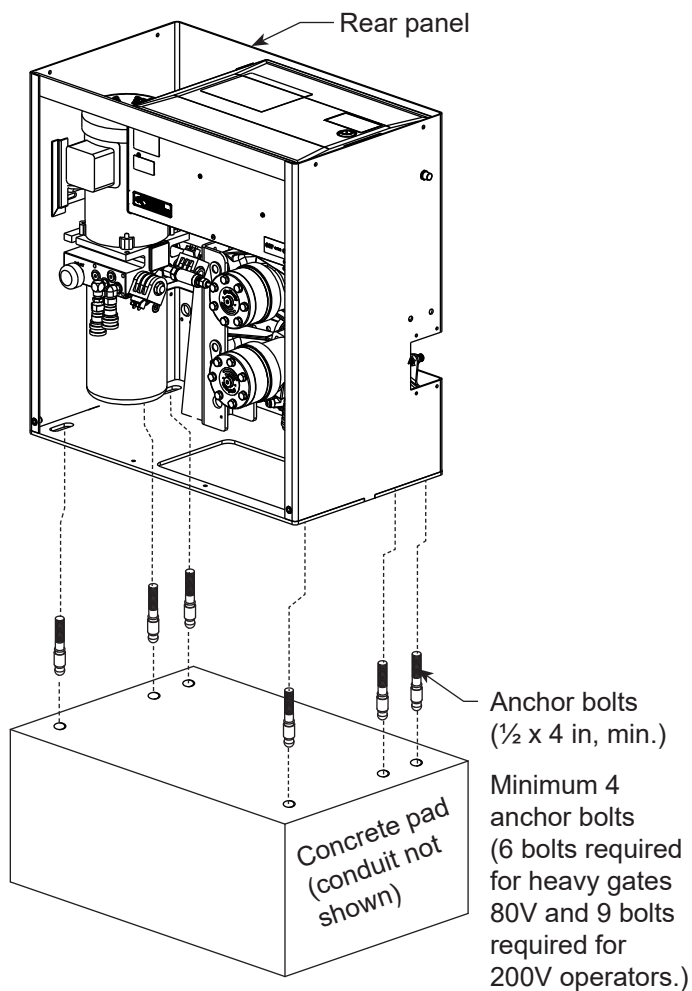

## Base Riser Installation and Dimensions

### Option:

SlideDriver II Base Riser (most models)

Inches: 26W x 12H x 14½D

Millimeters: 660W x 300H x 368D

### Option:

SlideDriver II Base Riser (200 series)

Same H & D

47 in W (1090 mm)

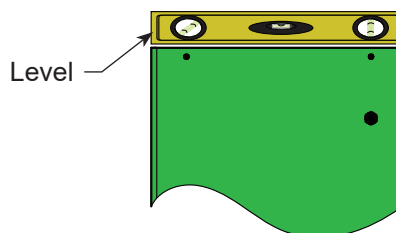
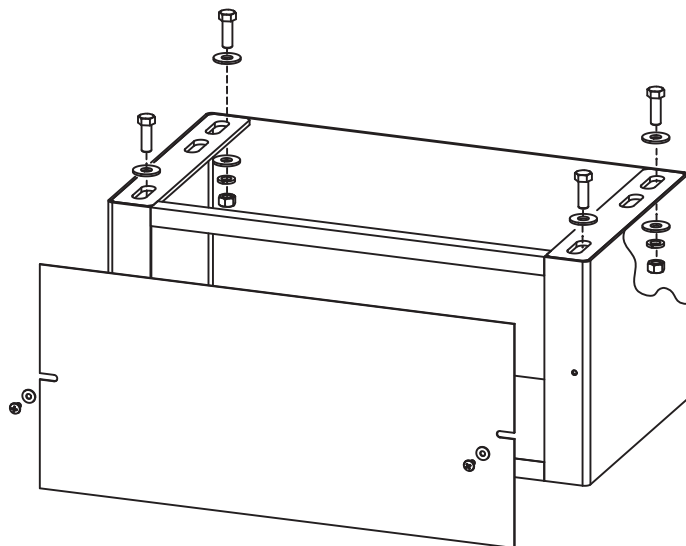

Side view

## INSTALL THE EARTH GROUND

### DANGER

The potential for lightning discharge exists with all gates, fences, and gate operators. National Electric Code (NEC) - Article 250 requires a separate earth ground in addition to the required equipment ground. Ga. 6 minimum.

The gate operator must be grounded per NEC, NFPA 780 and local building standards and codes.

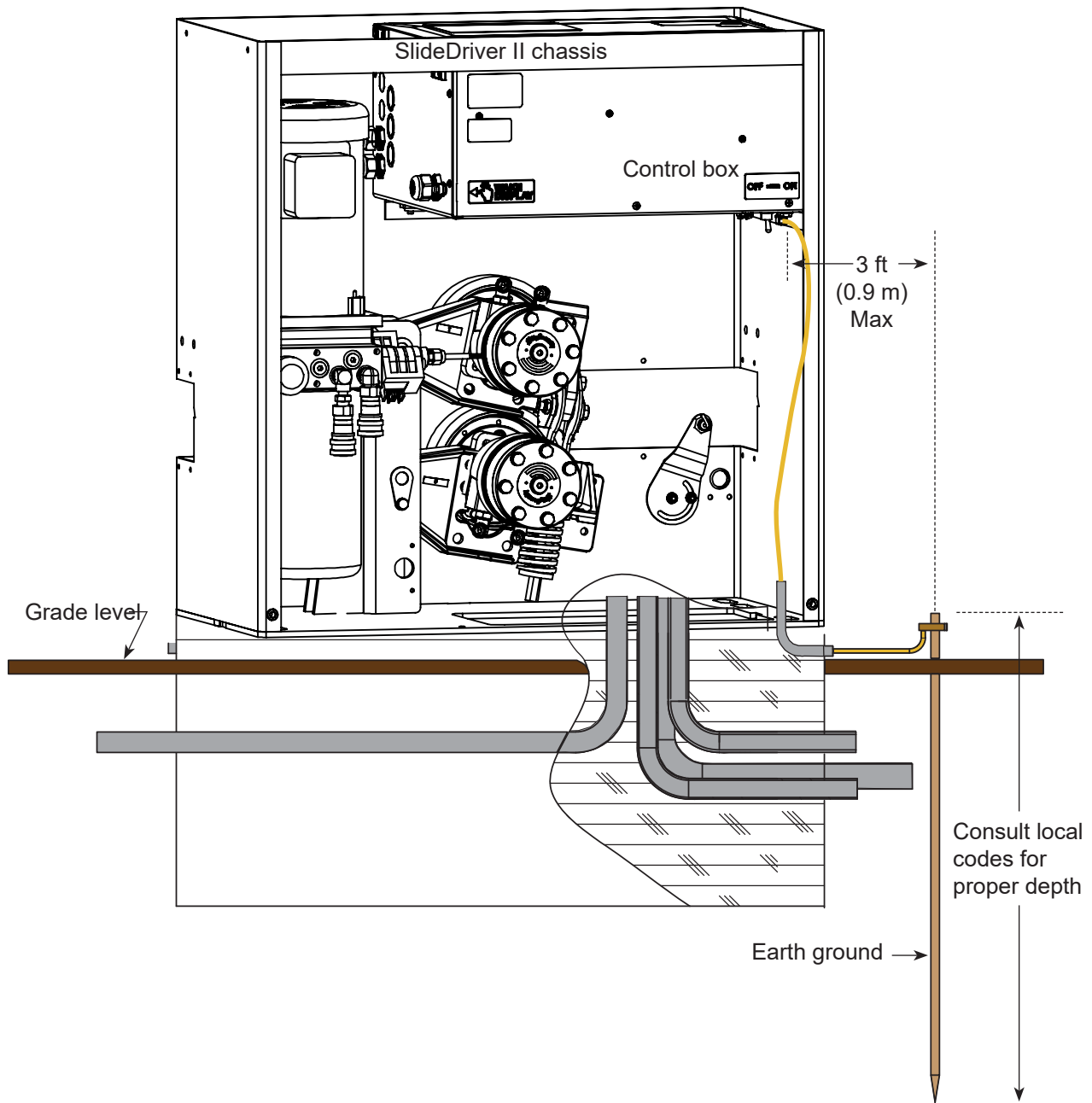

# ASSEMBLE, ALIGN, AND INSTALL DRIVE RAIL

## NOTICE

SlideDriver II is designed for use with HySecurity drive rail. Failure to use HySecurity drive rail could decrease performance, reduce durability, and may void the warranty.

### Connect Sections of the Drive Rail

1. Use roll pins to join the sections of the drive rail. To prevent the pins from moving during assembly, crimp the pin channels with pliers (Figure 5).

### Secure the Toggle Handle

2. Disengage the drive wheels by firmly grasping and pulling on the toggle handle (Figure 6).

## WARNING

Be careful where you place your hands and fingers when you disengage the drive wheels. The compression spring at the base of the clamp causes the handle to drop suddenly which can cause serious injury.

3. Secure the toggle handle clamp in the open position so the upper wheel does not fall closed when you insert the drive rail through the chassis.

## CAUTION

When drive rail is installed, the drive rail must be aligned and the operator chassis secure before clamping the drive wheels and adjusting the compression spring.

## CAUTION

When sliding the drive rail through the cut out in the chassis, DO NOT damage the limit sensor. Damage to the limit sensor during installation is not covered by the Warranty.

### Clamp Drive Rail to Gate

4. Identify the gate structure nearest the operator and temporarily clamp the drive rail onto the gate.

### Set Drive Rail Depth with a Laser

5. For reference, run a string line or laser along the entire length of the drive rail. Compare the edge of the drive rail with the string line or laser. Place shims between the upright support structure and drive rail to keep the drive rail straight (Figure 7).

### Set Drive Rail Height with the Notches in the Chassis

6. Align the top of the drive rail with the notch on each side of the operator's chassis. If necessary, loosen the clamps and move the drive rail up or down along the length of the gate (Figure 9). Manually move the gate and repeat this step at each gate upright.

## NOTICE

The drive rail must not sag in the center or it will rub against dual limit sensors.

### Secure Drive Rail

7. Drill holes through the vertical drive rail flange and install U bolts along the upright support structure, as needed. HySecurity recommends that you attach a minimum of 3 supports per length of drive rail. Keep drive rail spans straight and level. Distance between attachment points should be less than 10 ft (3 m).

8. Remove the temporary clamps.

9. When the drive rail is fully secure, manually open and close the gate.

10. Check and adjust the height of the drive rail, as necessary.

Note: Over its entire length, the drive rail must be level and aligned with the label on the chassis to within + ¼ in (6 mm).

11. Install additional U bolts, as necessary.

Note: Move the operator as necessary to make sure the drive wheels will be centered on the drive track when placed under load.

12. With the drive rail secure, tighten the chassis anchor bolts.

# ASSEMBLE, ALIGN, AND INSTALL DRIVE RAIL

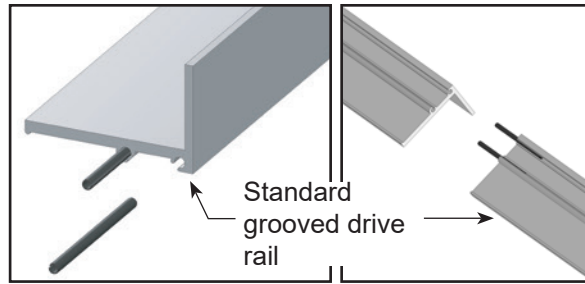
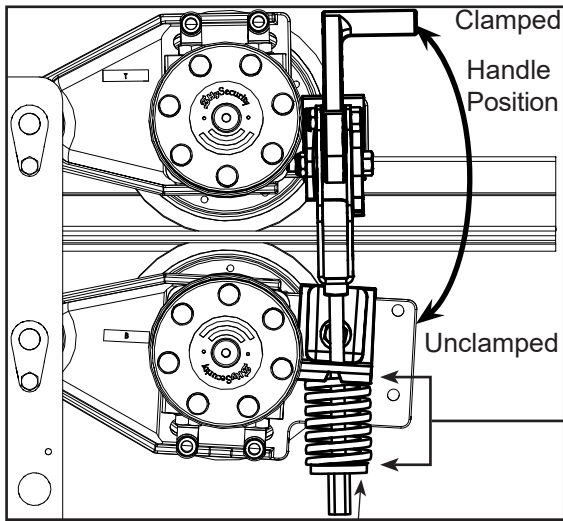

Figure 5. Assemble Drive Rail



Compression spring controls drive wheel gripping force

When clamped on the drive rail, the red spring should be compressed to a height of 2 in (50 mm). Adjust the nut at the base of the spring to set the proper tension.

Use wire to secure the toggle handle so the clamp remains open and the drive wheel does not fall closed.

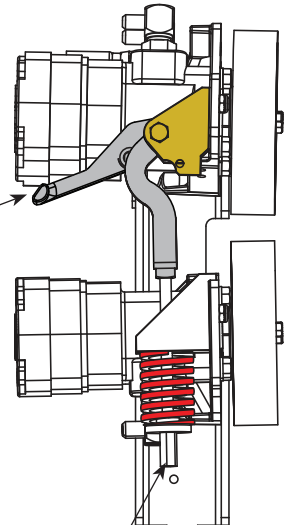

Nut adjusts tension

Figure 6. Secure Toggle Handle in Unclamped Position

Note: DO NOT use through bolts or self-tapping screws because you will not be able to adjust the drive rail at a later date.

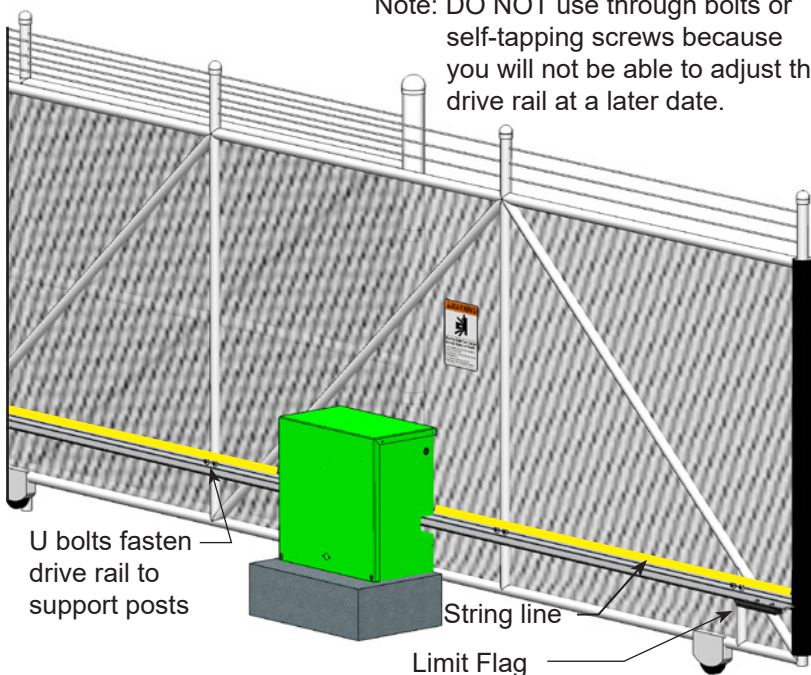

Figure 7. Set Drive Rail Depth

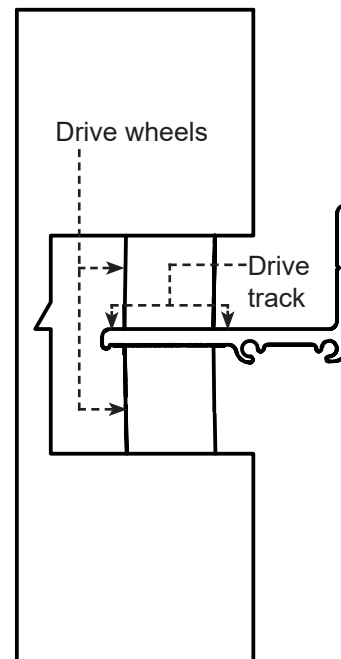

Figure 8. Center Drive Wheels

Drawings NOT to Scale

# ASSEMBLE, ALIGN, AND INSTALL DRIVE RAIL

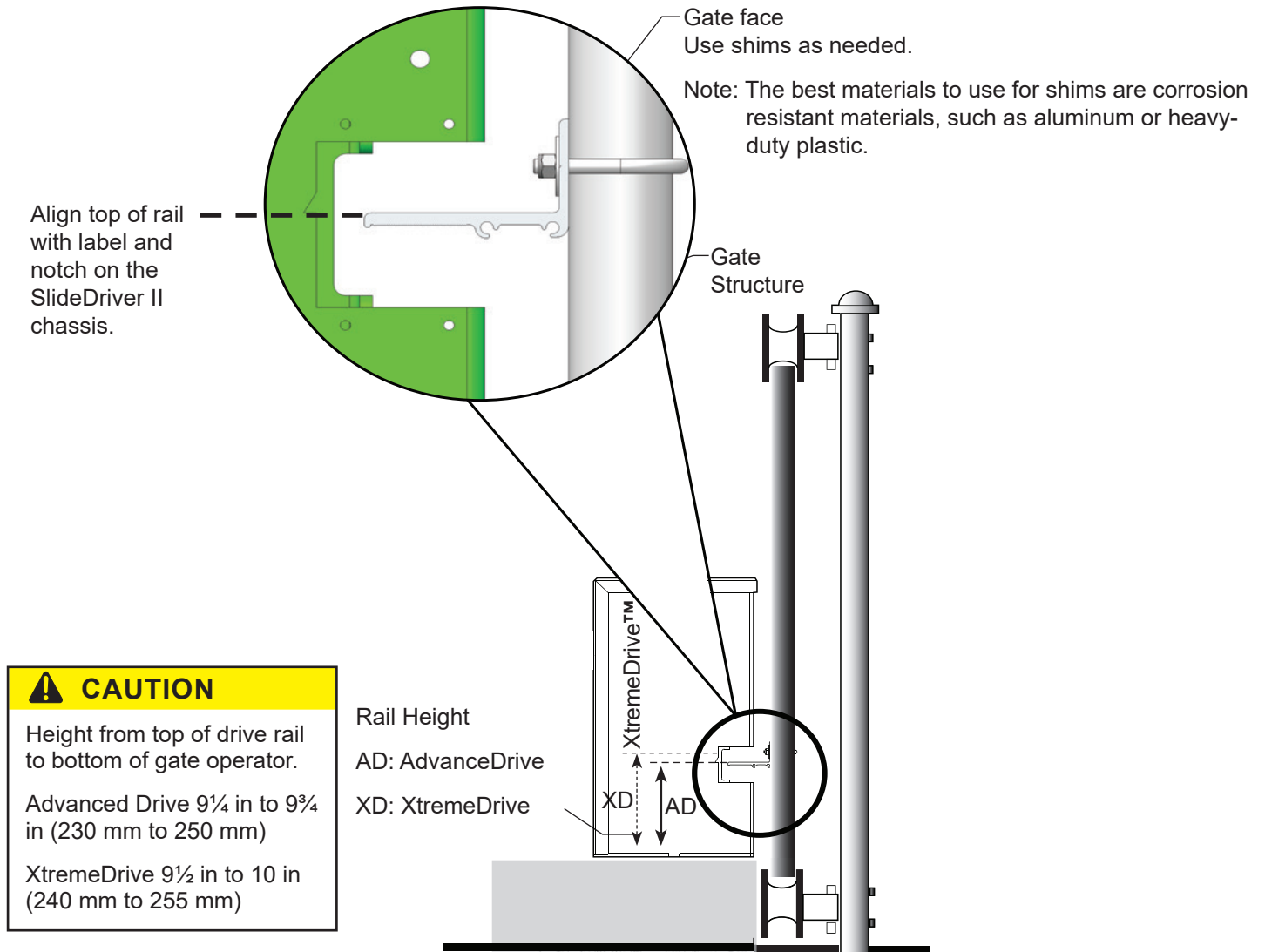

Figure 9. Set Drive Rail Depth and Height

Note: See "XtremeDrive Instructions" on page 113 for XtremeDrive installation instructions.

## CAUTION

Make sure power is disconnected and power switch is set to OFF while installing the limit flags and limit sensor.

**Table 1. Limit Tools**

$1\frac{1}{32}$ in drill bit
Two $1\frac{1}{16}$ in wrenches
Large Philips head screwdriver
$1\frac{1}{32}$ in socket
$\frac{1}{4}$ in socket

**Table 2. SD15, 40, 80V, 200V Limit Kit**

Part	Qty
12 in (305 mm) limit flag	2
Square nut $\frac{5}{16}$ -24	4
Pan head screw $\frac{5}{16}$ -24	4

**Table 3. SD50F Limit Kit**

Part	Qty
24 in (610 mm) limit flag	2
Square nut $\frac{5}{16}$ -24	8
Pan head screw $\frac{5}{16}$ -24	8

## NOTICE

### Limit Flag Handling (All SlideDriver II Models)

When facing the operator from the secure side of the gate, the black limit flag goes on the left side of the rail and the gray limit flag goes on the right side.

## Install Limit Flags

1. Move gate at least 2 in (50 mm) away from one end of travel (open or closed).
2. Set the height of the dual limit sensor  $\frac{7}{8}$  in (22 mm) above the bottom of the rail opening (Figure 10).

Note: (SD50F only) The right dual limit sensor is for the right limit flag and the left dual limit sensor is for the left limit flag.

3. Mark location of the center of the dual limit sensor on the drive rail (Figure 11).
4. Move gate further away from the end of travel by hand so the chassis does not interfere with limit flag installation.
5. Drill one hole 3 in (76 mm) from mark away from the operator and approximately 3 in (76 mm) from the edge of the drive rail (Figure 12 and Figure 14).
6. (SD50F) Drill another hole 9 in (230 mm) from mark toward operator and the same distance from the edge of the drive rail as the first hole.
7. Install a screw into each hole, thread a square nut onto each screw, and slide the limit flag onto the square nut (Figure 13).
8. Make sure the dual limit sensor is vertically centered on the limit flag face.
9. Set dual limit sensor spacing: loosen the two nuts ( $1\frac{1}{16}$  in) on the dual limit sensor, adjust the spacing between the dual limit sensor and stop limit flag face to  $\frac{1}{4}$  to  $\frac{3}{4}$  in (6 to 19 mm), and tighten the nuts to hold this spacing (Figure 14).
10. When power is connected, cycle gate to test limit.
11. Adjust limit flag position until the gate stops at the right place.
12. Tighten the limit flag screw.
13. Install more screws spaced approximately 6 in (152 mm) along the limit flag. 2 screws for a 12 in limit flag or 4 screws for a 24 in limit flag (Figure 15).
14. Repeat steps 1 through 13 for the opposite end of travel.



# INSTALL AND SECURE LIMITS

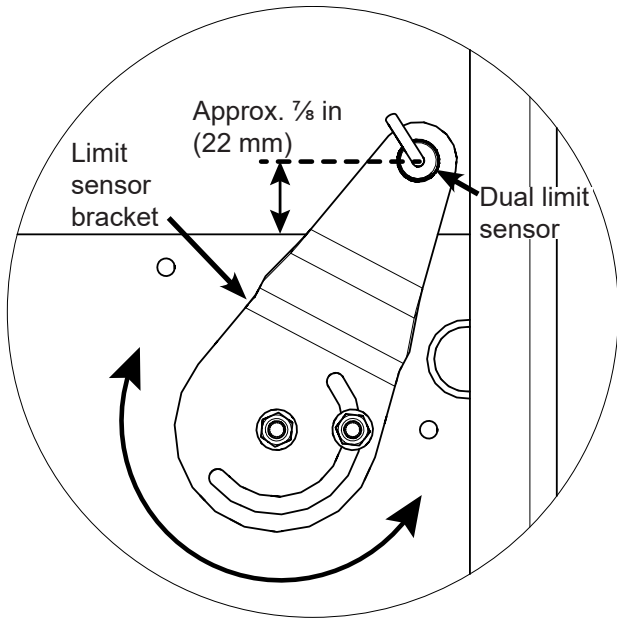

Figure 10. Set Limit Sensor Height

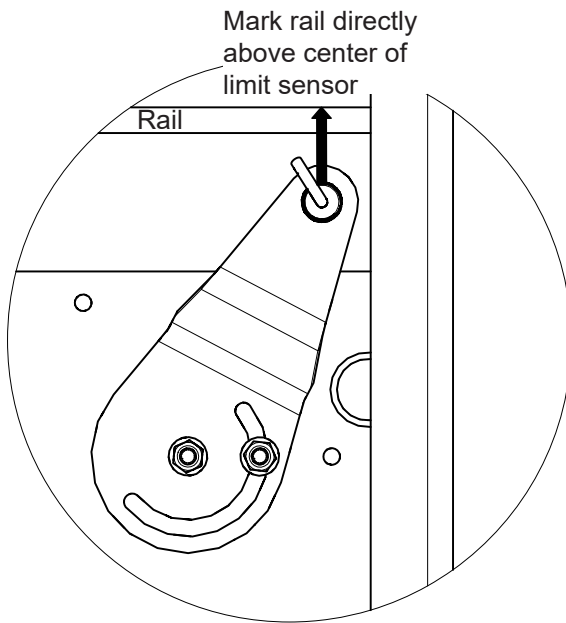

Figure 11. Mark Limit Sensor Location on Rail

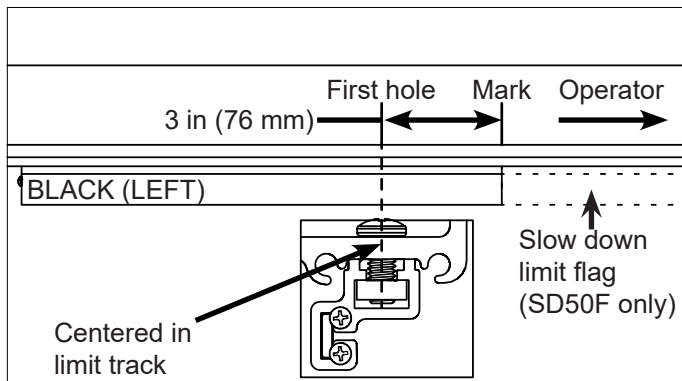

Figure 12. Drill First Limit Flag Hole (Left Limit)

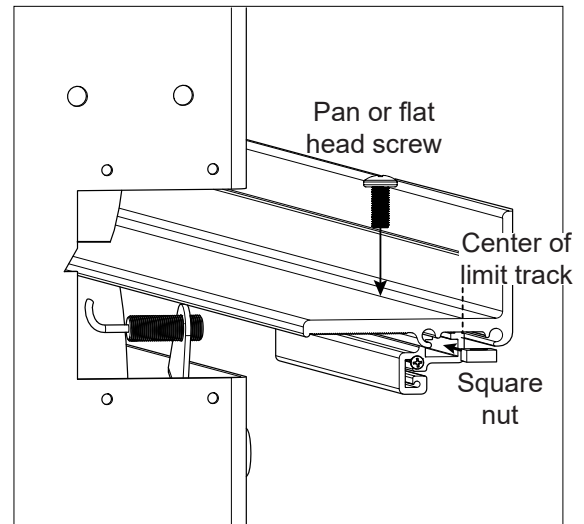

Figure 13. Install Limit Flag

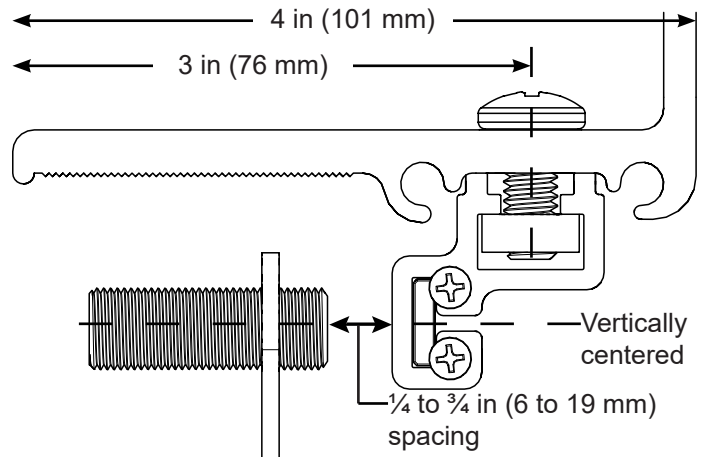

Figure 14. Set Dual Limit Sensor Spacing

Note: For SlideDriver II operators, the limit flags are installed in the limit track and should not cross the path of the drive wheels in the drive track.

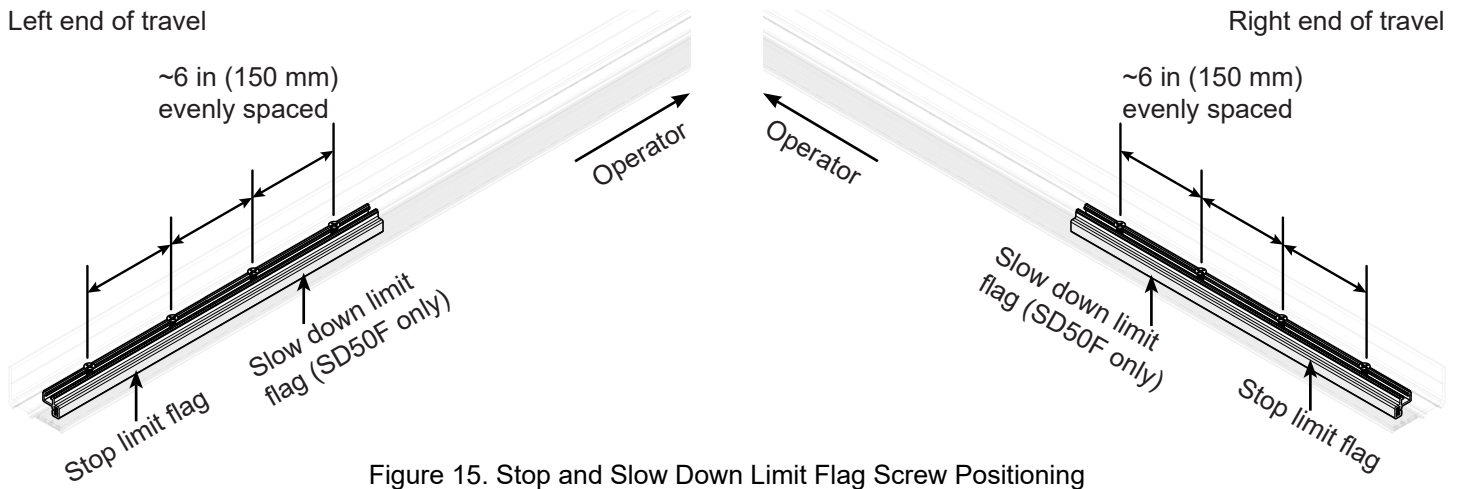

Figure 15. Stop and Slow Down Limit Flag Screw Positioning

## CLAMP DRIVE WHEELS

### All SlideDriver II

Refer to page 22 for WARNING. Place toggle handle in clamped (load) position.

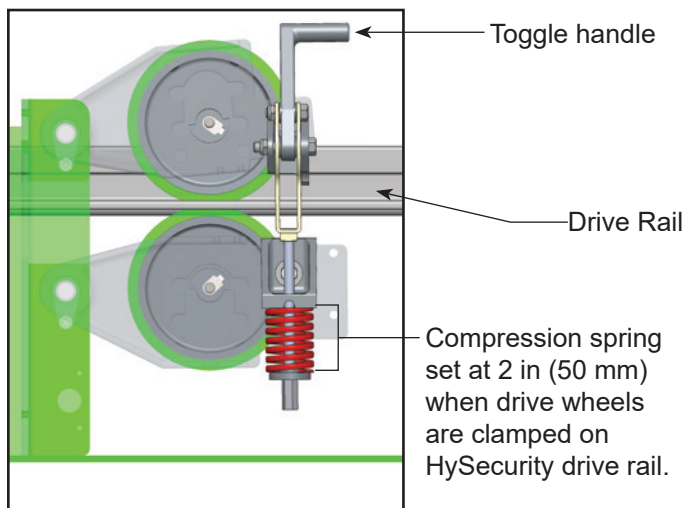

Figure 16. Toggle Handle Assembly

# FLANGED DRIVE RAIL AND LIMIT FLAGS

The flanged drive rail installation is similar to the standard drive rail installation.

Make sure the flanged drive rail is aligned with the notch in the chassis (Figure 9).

Make sure the drive wheels are centered in the drive track (Figure 8).

Make sure the limit flag screws are centered in the limit track (Figure 12 and Figure 13).

After each screw is installed on the flanged drive rail install limit flag spacers on the screw before the square nut (Figure 17).

Make sure the dual limit sensor is centered on the limit flag (Figure 14).

## NOTICE

The drive rail must not sag in the center or it will rub against dual limit sensor(s).

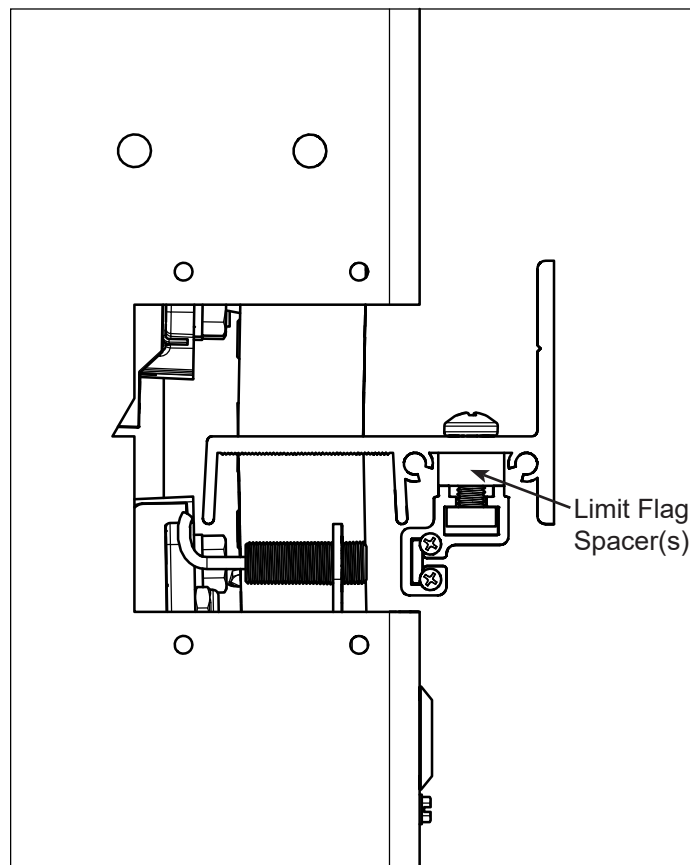

Figure 17. Flanged Drive Rail with Limit Flag and Spacer

## **⚠ DANGER**

Turn off AC power at the source (circuit breaker panel) before accessing the wires in the gate operator. Follow facility Lock Out/Tag Out procedures. Make sure all power switches are in the OFF position. Follow all electrical code standards and regulations.

## **⚠ WARNING**

Each gate operator is built to run on a specific line power voltage and phase. Failure to ensure that the source voltage, phase, and frequency match as specified on the equipment may result in severe damage to the equipment.

## **⚠ CAUTION**

Wiring of gate operators must conform to NFPA and NEC standards and comply with all local codes. When the installation is compliant and complete, turn on AC power at the source and at the control box. For Variable Frequency operators, make sure the connection wires match the voltage found on the operator's nameplate.

## POWER CONNECTIONS

Size the primary wires, appropriately. Consider the voltage, horsepower, and length of the wire run from the main power panel. The electrical wiring must be properly routed through conduit that enters the gate operator through its base cutout and feeds through one of the knockouts in the control box.

Verify the site input voltage and phase match what is marked on the operator.

- 1. Connect to Power:** Pigtails are provided for connection of input power.

Note: Make sure a 20A circuit (minimum) protected with a 20A Inverse Time Breaker is provided for all AC power connections.

Note: 50F and 80V 1Ø operators require 30A breaker as well as 200V 3Ø operators. All other AC operators require 20A breakers.

## TURNING THE POWER SWITCH ON

The power disconnect switch (power switch) is located on the bottom right of the electrical enclosure.

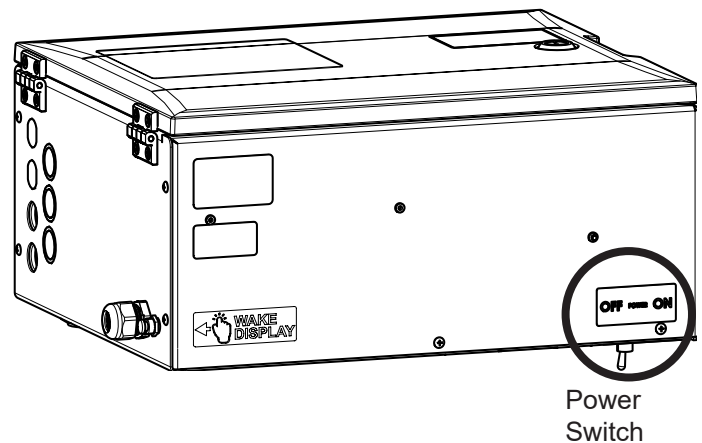

Figure 18. Power Switch

# WIRING AC POWER

## SITE POWER CONSIDERATIONS

HySecurity gate operators are intended for permanent installation. Make sure you prepare the site with the following considerations:

- Make sure all electrical wiring is properly routed via conduits.
- Check the distance of the wiring run from the main panel to the gate operator. Make sure the wire size of the branch circuit supplying power to the gate operator is large enough to avoid excess voltage drop. Refer to Wire Sizing and Runs on page 32.
- Make sure the available power source matches the electrical requirements specified on the voltage nameplate.
- Make sure a 20-amp circuit (minimum) protected with a 20-amp Inverse Time Breaker (slow blow) is provided for all AC power connections.
- Verify that the operator is electrically grounded per NFPA 780 and NEC Article 250 and local codes.

## CHANGING ELECTRICAL CONNECTIONS IN THE FIELD

### CAUTION

For in-field conversions, the NEC requires that the voltage label on the motor be changed to match the new configuration. Contact HySecurity for a replacement label.

To reconnect the electric motor and the 24V control transformer, refer to the motor connection diagram found either on the motor's nameplate or inside the motor connection box. Be sure to read the WARNINGS below if planning to convert from 1Ø to 3Ø, or vice versa. The electric motor will need to be replaced.

### WARNING

In-Field, Variable Frequency Drive Connections: SlideDriver operators are NOT field re-configurable for 1Ø or 3Ø, 208/230VAC input power without changing the VFD. Also, if reconfiguring from 208/230VAC to 460/480VAC the VFD Motor Controller in a 208/230VAC unit must be replaced with a VFD Motor Controller manufactured for the higher (460/480VAC) voltage input. Any electrical damage occurring to the operator will not be covered by the Warranty.

### WARNING

SlideDriver II 50F-series and all 2 hp operators CANNOT be connected to 115/120VAC, 1Ø power or 575V, 3Ø power. If any attempts are made to do so, serious injury and possible electrical shock may result. Any electrical damage occurring to the operator will not be covered by the Warranty.

Supplying a gate operator with the correct electrical service is crucial to the performance of the operator and the life of its electrical components. If the wire size used is too small, the voltage loss, especially during motor startup, will prevent the motor from attaining its rated horsepower. The percentage of horsepower lost is far greater than the percentage of voltage loss.

A voltage loss can also cause the control components to chatter while the motor is starting, substantially reducing their life due to the resultant arcing. There is no way to restore lost performance resulting from undersized wires, except to replace them. To avoid costly rewiring, be sure to choose a sufficient wire size during site planning phases and at initial installation.

## NOTICE

DO NOT use undersized power wires. This can lead to power supply brown outs, SmartTouch 720/725 Controller resets, and premature motor failure.

The tables on the following page are based on copper wire and allow for a 5% voltage drop. The ampere values shown are the service factor ampere rating of the motor (maximum full load at continuous duty). At minimum, a 20A circuit (protected with a 20A Inverse time Breaker) should be provided depending on rated voltage of operator.

Always connect electrical power and ground the operator in accordance with the NFPA 780 & NEC, Article 430 and Article 250. Research and adhere to other local codes that may apply.

## LOW VOLTAGE CONTROL WIRING

The SmartTouch 720/725 Controller has very sensitive control inputs. The following is a chart of maximum distances for wire size:

Wire Size	Maximum Distance
18 ga	7.0 miles (11 km)
20 ga	3.5 miles (5.6 km)
22 ga	2.7 miles (4.3 km)
24 ga	2.0 miles (3.2 km)
26 ga	1.0 mile (1.6 km)
28 ga	3700 feet (1.1 km)

# WIRE SIZING AND RUNS

## SLIDEDRIVER II WIRING CHARTS (INCOMING POWER)

The maximum distance shown is from the operator to the power source, assuming that source power is from a panel box with adequate capacity to support the addition of this motor load. The values are for one operator, with no other loads applied to the branch circuit. Avoid placing more than one operator to a circuit, but if you must, be certain to reduce the maximum allowed wire distance by half.

Make sure proper wiring is being used. The following table shows the maximum allowable wire run from the power source to the operator for various wire sizes. Performance of SD50F-series operators on 1Ø and 3Ø, 50 or 60 Hz Power.

Note: Distance shown in U.S. Standard “feet.” Metric equivalent shown in parentheses.

Phase Ø	1	1	1	3	3	3
Voltage	115	208	230	208	230	460
Horsepower (Hp)	1	1	1	1	1	1
Maximum Rated Current Draw (A)	15.6	8.8	8.5	6.3	6.1	3.7
Wire Gauge	Distance	Distance	Distance	Distance	Distance	Distance
12	35 (11 m)	115 (35 m)	125 (38 m)	300 (91 m)	340 (104 m)	1135 (346 m)
10	55 (17 m)	185 (56 m)	205 (62 m)	475 (145 m)	545 (166 m)	1800 (549 m)
8	90 (27 m)	290 (88 m)	320 (98 m)	750 (229 m)	860 (262 m)	2835 (864 m)
6	140 (43 m)	450 (137 m)	500 (152 m)	1170 (357 m)	1340 (408 m)	4415 (1346 m)
4	220 (67 m)	705 (215 m)	780 (238 m)	1825 (556 m)	2085 (636 m)	6875 (2096 m)
2	335 (102 m)	1085 (331 m)	1200 (366 m)	2800 (853 m)	3200 (975 m)	10555 (3217 m)

Phase Ø	1	1	3	3	3	3
Voltage (V)	208	230	208	230	380	460
Horsepower (Hp)	2	2	2	2	2	2
Maximum Rated Current Draw (A)	19.9	17.8	13.7	12	8.7	8.1
Wire Gauge	Distance	Distance	Distance	Distance	Distance	Distance
12	150 (46 m)	175 (53 m)	230 (70 m)	295 (90 m)	675 (206 m)	870 (265 m)
10	240 (73 m)	280 (85 m)	370 (113 m)	470 (143 m)	1070 (326 m)	1385 (422 m)
8	380 (116 m)	440 (134 m)	585 (178 m)	745 (227 m)	1685 (514 m)	2180 (664 m)
6	590 (180 m)	685 (209 m)	910 (277 m)	1160 (354 m)	2625 (800 m)	3390 (1033 m)
4	915 (279 m)	1070 (326 m)	1415 (431 m)	1805 (550 m)	4080 (1240 m)	5275 (1608 m)
2	1405 (428 m)	1640 (500 m)	2165 (660 m)	2765 (843 m)	6255 (1907 m)	8085 (2464 m)

200V table on next page.



**Table 6. SlideDriver II Wire Size Chart – SD200V**

Phase Ø	3	3	3	3
Voltage (V)	208	230	380	460
Horsepower (Hp)	5	5	5	5
Maximum Rated Current Draw (A)	26	22.7	15.6	13.2
<b>Wire Gauge</b>	<b>Distance</b>	<b>Distance</b>	<b>Distance</b>	<b>Distance</b>
12	57 (18 m)	73 (22 m)	175 (53 m)	253 (77 m)
10	90 (27 m)	115 (35 m)	280 (85 m)	400 (122 m)
8	145 (44 m)	183 (56 m)	440 (134 m)	633 (193 m)
6	225 (69 m)	285 (87 m)	688 (210 m)	985 (300 m)
4	350 (107 m)	445 (136 m)	1070 (326 m)	1533 (467 m)
2	540 (165 m)	683 (208 m)	1645 (501 m)	2353 (717 m)

# CONTROLLER CONNECTIONS

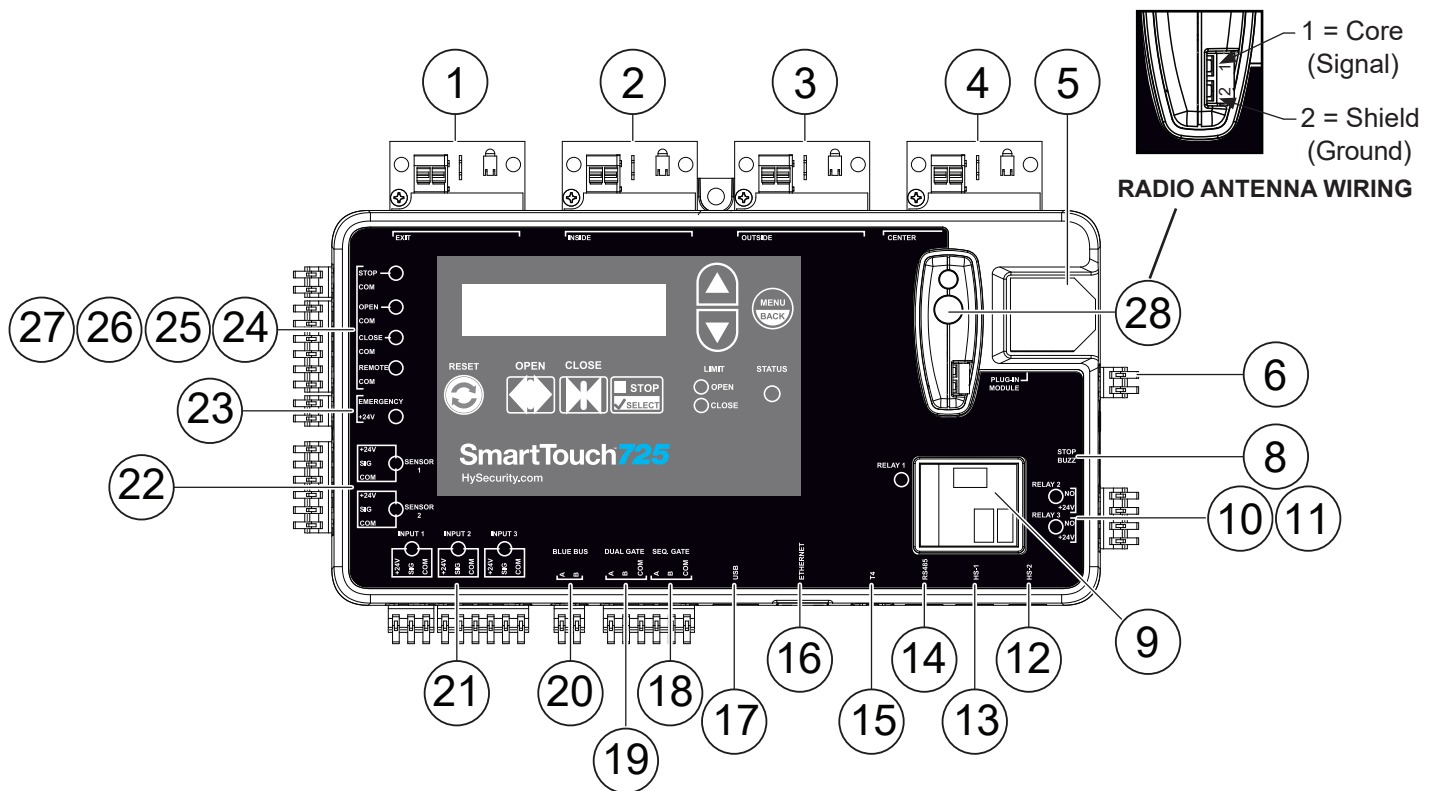

Figure 19. SmartTouch 720/725 Controller Connections

1. **Hy5B EXIT Loop** – This opens a fully closed gate or reopens a closing gate.
2. **Hy5B INSIDE Loop** – Reversing loop on secure side.
3. **Hy5B OUTSIDE Loop** – Reversing loop on public side.
4. **Hy5B CENTER Loop** – Detect vehicle in swing arc of the gate (swing gate only)
5. **(Not Used)**
6. **OXI Antenna** – For use with old OXI receivers that do not have an antenna connection.\*
8. **Stop/Buzzer Harness**
9. **Relay 1** – Mechanical relay
10. **Relay 2** – Solid state relay
11. **Relay 3** – Solid state relay
12. **HS-2** – Can connect to VFD, HyInverter, or I/O Expansion Module.
13. **HS-1** – Harness connects communication to I/O Expansion Module (OT1 and OT7, MN3).
14. **RS485** – Standard VFD Input
15. **(Not Used)**
16. **Ethernet** – See Network Setup Menu in the External Communications Menu on page 80.\*
17. **USB** – Used for firmware updates and fault log download.
18. **Sequenced Gate Connection**
19. **Dual Gate Connection**
20. **BlueBUS** – For use with NICE BlueBUS devices\*
21. **Programmable Inputs 1-3**
22. **Programmable Sensor Inputs 1-2** – UL 325 required external entrapment sensors
23. **Emergency** – Programmable to fire department open or emergency close
24. **Remote** – Programmable for three functions, defaults to step function
25. **Close** – Close only input
26. **Open** – Open only input
27. **Stop** – Stop and reset input
28. **OXI** – Radio for NICE access control devices.\*

\* Some features not available on SmartTouch 720.

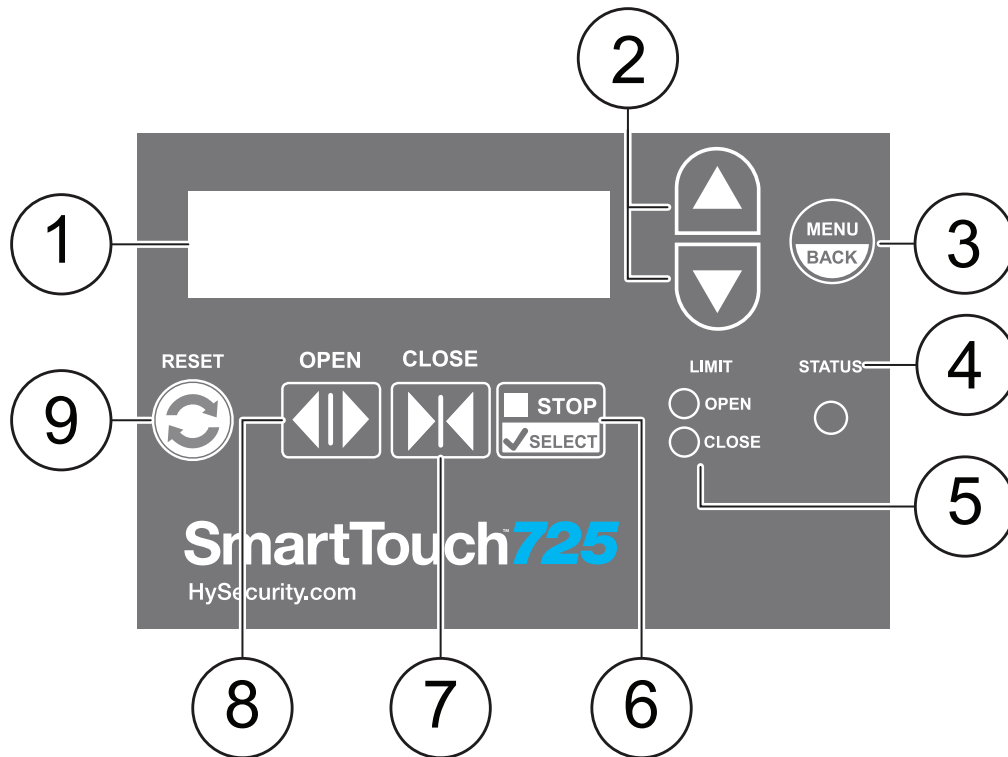

Figure 20. SmartTouch 720/725 Controller User Interface

1. **OLED Display** – 16 characters per line, 2 line display. Displays current operator status, menus, and alerts/faults/errors. In h6.03 and later firmware, the display will shut off when none of the on board buttons have been pressed for a while. Pressing any button will turn it back on. This is to save power and extend the life of the display.
2. **Up/Down Arrows** – Navigate through menu and display options while in Menu Mode.
3. **Menu/Back** – Open the configuration menu from the operator status display. Go back from the current menu (exit the current menu).
4. **Status LED** – Indicates gate operator status
  - a. Flashing Red – An Alert, Fault, or Error has occurred. Immediately shut down the machine and correct the fault.
  - b. Solid Red – Operator is in Menu Mode
  - c. Flashing Green – Operator is in Run Mode
  - d. Flashing Blue – Operator is pairing with a Bluetooth device.
  - e. Alternating Blue and Red/Green – Operator is communicating with a Bluetooth device.
5. **Limit Open/Close** – Solid green when limit flag activates limit sensor.
6. **Stop/Select** – Stops gate travel when in run mode. Press to select current menu option or to confirm setting value
7. **Close** – Closes the gate while in Run Mode.
8. **Open** – Opens the gate while in Run Mode.
9. **Reset** – Press to clear faults and return to Run Mode. Not functional in Menu Mode.

# INITIAL SETUP

## NAVIGATE THE MENUS

Press MENU/BACK to enter the menus or to exit the current screen (up one level without saving any changes).

Press the UP or DOWN arrow to change the current selection until you find the one you want.

Press SELECT to access the menu or sub-menu. Press SELECT to accept the current option or value.

Note: These navigation instructions are the same throughout the SmartTouch 720/725 Controller menus.



## CONFIGURE THE SETUP MENU

The first time the SmartTouch 720/725 Controller powers on set USAGE CLASS and GATE HANDING before normal operation.

1. Set the power switch to ON the first time. Firmware version appears on the display and then USAGE CLASS - 0.
2. Press SELECT, press the UP or DOWN arrow to navigate to the correct USAGE CLASS, and press SELECT to accept value.
3. Press the UP or DOWN arrow until GATE HANDING appears on the display, press SELECT, press the UP or DOWN arrow to navigate to the correct option, and press SELECT to accept value.
4. STARTING UP flashes on the display.
5. The SmartTouch 720/725 Controller automatically scans for BlueBUS devices and then gate status appears on the display.

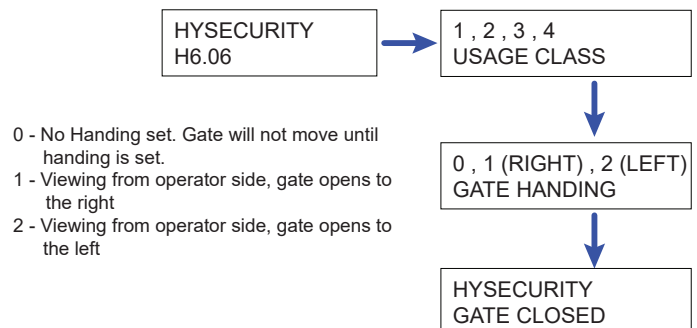
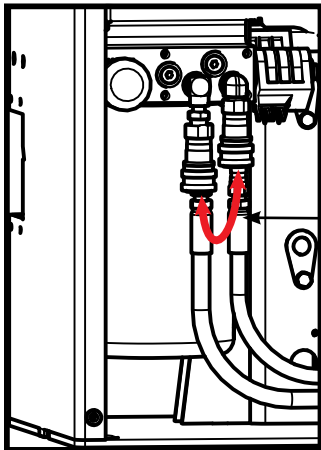

Figure 21. Configuring Setup Menu

## HYDRAULIC HOSE SWAP

Once power is connected (see page 29), check that the gate moves in the open direction when you press OPEN and moves in the close direction when you press CLOSE. If necessary, swap the hydraulic hoses at the location shown to change the operator handing.



SlideDriver II is set to Right Hand configuration by default.

Swap hydraulic hoses for Left Hand configuration.

Figure 22. Swap Hydraulic Hoses for Gate Handing

### NOTICE

Do not operate SlideDriver II gate operators while the hoses are disconnected. Make sure that all hydraulic hoses are securely installed before operating the motor.

## CHECK LIMIT FLAG HANDING

Check the limit flag handing matches the Open and Close Limit on the SmartTouch 720/725 Controller (Figure 20, Item 5).

1. Set power switch to OFF.
2. Unclamp toggle handle and secure it in the open position.
3. Set power switch to ON.
4. Move gate to the open or close limit.
5. Check that the appropriate limit activates according to the SmartTouch 720/725 Controller (Figure 20, Item 5).
6. Move gate to the other limit and confirm that the opposite limit activates on the SmartTouch 720/725 Controller.
7. Set operator power to OFF, move gate to open position, and clamp the toggle handle.
8. Set operator power to ON.

## ADJUST THE BRAKE VALVES (SD40, 50F, 80V, 200V)

The brake valves, one for each direction of travel, determine how quick the gate stops. Proper adjustment of the brake valves is important for smooth operation of the gate.

From factory setting, a clockwise adjustment allows the hydraulic fluid to flow more freely. If the adjustment is set too far clockwise, the gate may stop at inconsistent locations or crash into the end of travel. If the adjustment is set too far counterclockwise, the system pressure will increase, the gate speed may decrease, and the gate will stop more abruptly causing excessive wear or damage.

For the brake valves to have time to bring the gate to a smooth stop, the limit flags must trigger the limit sensor at least 2 in (51 mm) before end of gate travel.

### NOTICE

Improper brake valve adjustment can cause the gate to crash into the end of travel or stop abruptly causing damage or excessive wear. Make sure brake valves are adjusted properly.

Brake valves are factory set to midpoint, two turns. Check brake valve function before making any adjustments.

1. If adjustment is needed, loosen the  $\frac{9}{16}$  in lock nut on the top of the brake valve and turn the adjustment stem with a hex key  $\frac{1}{4}$  turn at a time.
2. When the adjustment is complete, tighten the lock nut to hold the setting.

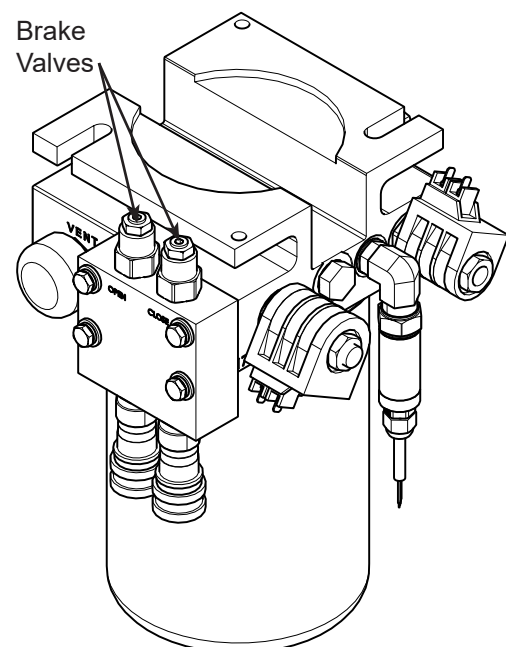
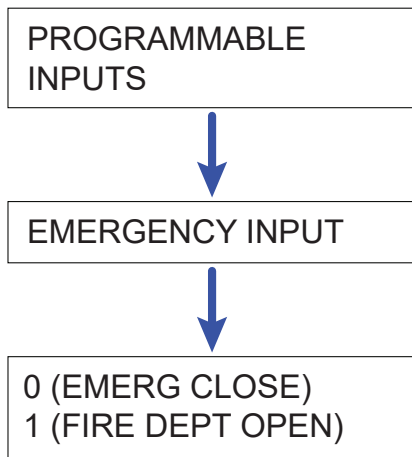
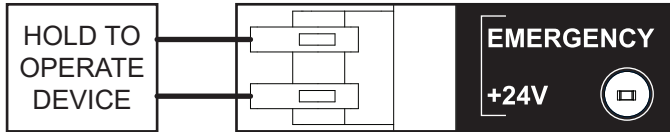

Figure 23. Brake Valves

# SD50F EMERGENCY FAST OPERATE (EFO)

SlideDriver II EFO ignores loops and entrapment sensors. SlideDriver II operators equipped with a VFD will run at the high speed setting when EFO is activated.

For EFO operation connect a hold to operate device to the Emergency input and program the input. Set to 1 (FIRE DEPARTMENT OPEN) for emergency open or 0 (EMERGENCY CLOSE) for emergency close



# SMARTTOUCH 720/725 CONTROLLER MENUS

---

These are the top level menus in the SmartTouch 720/725 Controller. The following pages show the submenus with settings and descriptions. These menus are also accessible through the Smart installer app.

OPERATOR  
CONFIGURATIONS

OPERATOR  
FUNCTIONS

OPERATOR  
COMMUNICATIONS

PROGRAMMABLE  
INPUTS

ENTRAPMENT  
SENSOR RESPONSE

USER RELAY  
OUTPUTS

LOOP  
OPTIONS

EXTERNAL  
COMMUNICATIONS

EXPANSION BOARD  
INPUTS

DIAGNOSTICS  
MENU

24/7 CLOCK  
AND TIMER



# OPERATOR CONFIGURATIONS

## SlideDriver II 15, 40 (OT 1)

OPERATOR CONFIGURATIONS	
USAGE CLASS	0 (GATE DISABLED) <sup>†</sup> 1 (RESIDENTIAL) 2 (PUBLIC) 3 (INDUSTRIAL) 4 (HIGH-SECURITY)
CLOSE TIMER	0 (OFF) <sup>†</sup> 1 - 99 (SECONDS)
GATE HANDING	0 (NOT ASSIGNED) <sup>†</sup> 1 (RIGHT) 2 (LEFT)
AC/DC GATE	0 (DISABLED) <sup>†</sup> 1 (AC POWERED) 2 (DC HYCHARGER) 3 (AC HYINVERTER)
AC LOSS	0 (UPS FAIL OPEN) <sup>†</sup> 1 (UPS FAIL CLOSE) 2 (AUTO OPEN) 3 (NO CLOSE TIMER)
OPEN TIME ALERT	0 (0 SECS) 1 (15 SECS) 2 (45 SECS) <sup>†</sup> 3 (75 SECS) 4 (105 SECS) 5 (135 SECS)
LOITERING ALERT	0 (0 SECS) 1 (15 SECS) 2 (45 SECS) 3 (75 SECS) <sup>†</sup> 4 (105 SECS) 5 (135 SECS)
FACTORY DEFAULTS	0 (CUSTOM) <sup>†</sup> 1 (RESET TO)
OPERATOR TYPE 1 <sup>†</sup>	1-17 (OPERATOR TYPE)
MENU PIN	0 0 0 0

## SlideDriver II 50F, 80V, 200V (OT 7)

OPERATOR CONFIGURATIONS	
USAGE CLASS	0 (GATE DISABLED) <sup>†</sup> 3 (INDUSTRIAL) 4 (HIGH-SECURITY)
CLOSE TIMER	0 (OFF) <sup>†</sup> 1 - 99 (SECONDS)
GATE HANDING	0 (NOT ASSIGNED) <sup>†</sup> 1 (RIGHT) 2 (LEFT)
MODEL NUMBER	0 (DISABLED) <sup>†</sup> 1 (50F) 2 (80V) 3 (200V)
AC/DC GATE	0 (DISABLED) <sup>†</sup> 1 (AC POWERED) 2 (DC HYCHARGER) 3 (AC HYINVERTER)
AC LOSS	0 (UPS FAIL OPEN) <sup>†</sup> 1 (UPS FAIL CLOSE) 2 (AUTO OPEN) 3 (NO CLOSE TIMER)
OPEN TIME ALERT	0 (0 SECS) 1 (15 SECS) 2 (45 SECS) <sup>†</sup> 3 (75 SECS) 4 (105 SECS) 5 (135 SECS)
LOITERING ALERT	0 (0 SECS) 1 (15 SECS) 2 (45 SECS) 3 (75 SECS) <sup>†</sup> 4 (105 SECS) 5 (135 SECS)
FACTORY DEFAULTS	0 (CUSTOM) <sup>†</sup> 1 (RESET TO)
OPERATOR TYPE 7 <sup>†</sup>	1-17 (OPERATOR TYPE)
MENU PIN	0 0 0 0

<sup>†</sup> = Indicates default

# OPERATOR CONFIGURATIONS

**Table 7. SmartTouch 720/725 Operator Configurations Settings**

MENU DISPLAY	SETTINGS	DESCRIPTION
USAGE CLASS	0 = Gate disabled <sup>†</sup> 1 = Residential 1 to 4 units 2 = Comm./public access 3 = Light industrial 4 = Industrial secure	Assign the operator's Usage Class designation per UL 325 standards. The installer must designate a usage class before the operator will function. VFD controlled models are only rated for Usage Class 3 and 4 installations.
CLOSE TIMER	0 = Off <sup>†</sup> 1-99 (seconds)	Number of seconds before open gate initiates closure after all inputs are clear.
GATE HANDING	0 = NOT ASSIGNED <sup>†</sup> 1 = RIGHT 2 = LEFT	Designates which way a gate opens viewed from operator. If it opens to the left, it is a left-hand gate.
MODEL NUMBER (OT7 ONLY)	0 = DISABLED <sup>†</sup> 1 = 50F 2 = 80V 3 = 200V	Assign the operator's Model Number. Preset at factory based on what operator was ordered.
AC/DC GATE	0 = DISABLED <sup>†</sup> 1 = AC POWERED 2 = DC HYCHARGER 3 = AC HYINVERTER	Assign the operator's power type. Preset at factory based on what operator was ordered.
AC LOSS	0 = UPS FAIL OPEN <sup>†</sup> 1 = UPS FAIL CLOSE 2 = AUTO OPEN 3 = NO CLOSE TIMER	Action operator performs during an AC power loss. Only appears when AC/DC GATE is set to 2 or 3.
OPEN TIME ALERT	0 = 0 (seconds) 1 = 15 2 = 45 <sup>†</sup> 3 = 75 4 = 105 5 = 135	Activates relay (function 8) when gate is open longer than selected time period.
LOITERING ALERT	0 = 0 (seconds) 1 = 15 2 = 45 3 = 75 <sup>†</sup> 4 = 105 5 = 135	Activates relay (function 13) when vehicle is over Outside Obstruction Loop with gate closed longer than selected time period.
LEARN LIMIT	0 = OFF <sup>†</sup> 1 = ON	(SLIDESMART ONLY) Set to 1 to place operator in learn limits mode. Installer must then set open and close limits.
FACTORY DEFAULTS	0 = CUSTOM <sup>†</sup> 1 = RESET TO	Set to 1 to erase all installer entered settings and return to factory defaults.
OPERATOR TYPE	OT1 = Non-VFD SLIDEDRIVER II OT7 = VFD SLIDEDRIVER II OT12 = SWINGSMART CNX OT15 = SLIDESMART CNX	Factory set. Used only if replacing the SmartTouch 720/725 Controller.
MENU PIN	0 0 0 0 ^	Allows installer to set a 4-digit security pin to restrict access to SmartTouch 720/725 Controller menus.

# OPERATOR FUNCTIONS

---

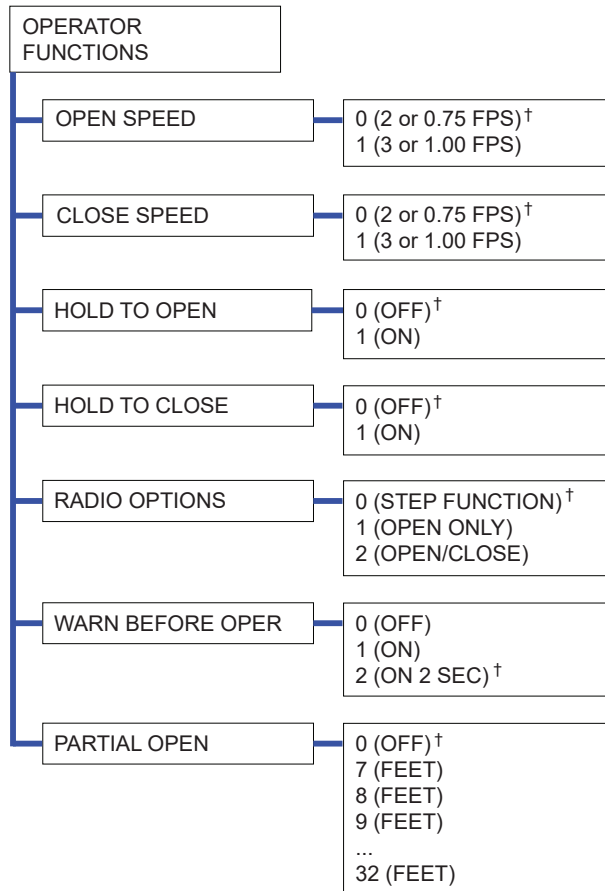

**Table 8. SmartTouch 720/725 Operator Functions Settings**

MENU DISPLAY	SETTINGS	DESCRIPTION
OPEN SPEED	0 = 2 FPS or 0.75 FPS <sup>†</sup> 1 = 3 FPS or 1.00 FPS	Designates how quickly gate moves in the open direction. Hidden for all OT1 and OT7, AD2.
CLOSE SPEED	0 = 2 FPS or 0.75 FPS <sup>†</sup> 1 = 3 FPS or 1.00 FPS	Designates how quickly gate moves in the close direction. Hidden for all OT1 and OT7, AD2.
HOLD TO OPEN	0 = OFF <sup>†</sup> 1 = ON	Set to 0 to produce a gate open when a momentary signal is transmitted. Set to 1 if a constant hold to open signal, such as a push button control, is being used. 0 = Momentary open signal 1 = Constant hold open push button required. You must set HOLD TO OPEN to 1 to comply with UL 325 Type D protection.
HOLD TO CLOSE	0 = OFF <sup>†</sup> 1 = ON	Set to 0 to produce a gate closure when a momentary signal is transmitted. Set to 1 if a constant hold to close signal, such as a push button control, is being used. A setting of 1 also deactivates the automatic close timer and causes its menu to disappear. 0 = Momentary open signal. 1 = Constant hold open push button required. You must set HOLD TO CLOSE to 1 to comply with UL 325 Type D protection.
RADIO OPTIONS	0 = STEP FUNCTION <sup>†</sup> 1 = OPEN ONLY 2 = OPEN/CLOSE	Default setting is to function as a STEP function where each consecutive activation reverses or stops the gate. First activation opens the gate. Configures radio input for open only (1). If changed to setting 2 then adds capability for radio input to close gate, but only when gate is fully open.
WARN BEFORE OPER	0 = OFF 1 = ON 2 = ON 2 SEC <sup>†</sup>	Controls warn-before-operate buzzer and can be configured three ways: Set to 0: Buzzer is disabled Set at 0, buzzer will still beep when alerts, faults, errors, or entrapment are detected. Set to 1: Buzzer beeps for 3 seconds before gate motion begins and continues through entire gate travel. Set to 2: buzzer beeps for 3 seconds before gate motion begins and continues for 2 seconds of gate travel.
PARTIAL OPEN	0 (OFF) <sup>†</sup> 7 (FEET) 8 (FEET) 9 (FEET) ... 32 (FEET)	Sets distance (from closed gate position) where gate stops if the partial open input is activated. When a number is entered in PO display, open partial input becomes operational. Only available on slide gate operators.

**WARNING**

Do NOT cut wires to buzzer or unplug it as operator will not be in compliance with UL 325. Failure to comply may result in serious injury or death.

# OPERATOR COMMUNICATIONS

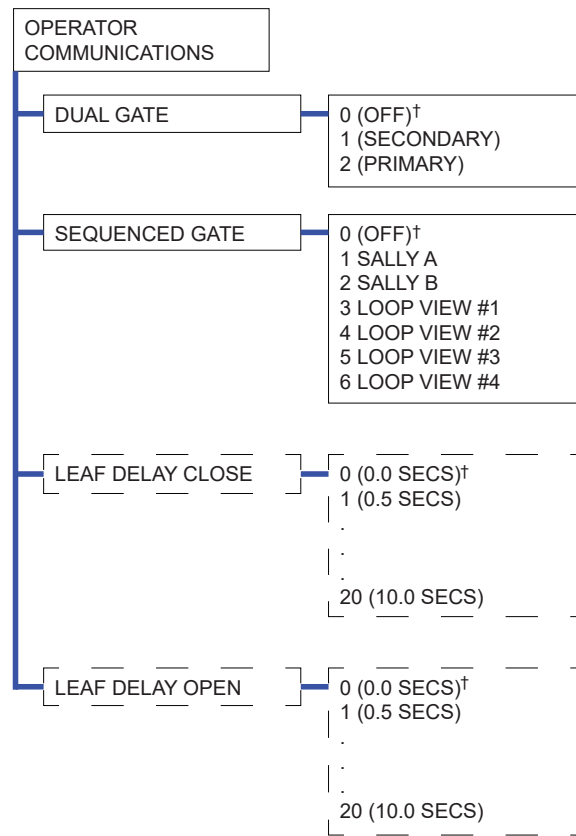

LEAF DELAY OPEN/CLOSE ONLY APPEAR IF THE GATE OPERATOR IS SET UP AS PRIMARY OR SECONDARY.

<sup>†</sup> = Indicates default

# OPERATOR COMMUNICATIONS

**Table 9. SmartTouch 720/725 Operator Communications Settings**

MENU DISPLAY	SETTINGS	DESCRIPTION
DUAL GATE	0 = OFF† 1 = SECONDARY 2 = PRIMARY	Configures gate operator as a Primary or as a Secondary in a dual-gate installation. When you assign one unit as Primary, you must configure the other as Secondary.
SEQUENCED GATE	0 = OFF† 1 = SALLY A 2 = SALLY B 3 = LOOP VIEW #1 4 = LOOP VIEW #2 5 = LOOP VIEW #3 6 = LOOP VIEW #4	<p>This menu is used to configure a Sally Port or Sequenced gate system. For a Sally Port, set one operator to Sally A and the other to Sally B. For sequenced gates, set both operators to the same Loop View setting.</p> <p>Establishes communication after wiring two or more gate operators as sequential gates.</p> <p><b>NOTE:</b> After selecting SEQUENCED GATE settings, set the CLOSE TIMER in each gate operator.</p>
LEAF DELAY CLOSE	0 = 0.0 (seconds)† 1 = 0.5 2 = 1.0 ... 20 = 10	Only appears if the gate operator is set up as PRIMARY or SECONDARY. Available settings are 1 through 20. Each increment adds 0.5 second time delay following a command to close before the operator activates. Provides up to a 10 second time before the gate starts closing.
LEAF DELAY OPEN	0 = 0.0 (seconds)† 1 = 0.5 2 = 1.0 ... 20 = 10	Only appears if the gate operator is set up as PRIMARY or SECONDARY. Available settings are 1 through 20. Each increment adds 0.5 second time delay following a command to close before the operator activates. Provides up to a 10 second time delay before the gate starts opening.

# DUAL AND SEQUENCED GATE SETUP

## Dual (or bi-parting) gate setup:

1. Install the primary and secondary operators.
2. Set up external entrapment sensors on both operators. Vehicle detectors may be installed in either operator. Make these connections before you connect the operators.
3. Test cycle the operators independently to make sure there are no problems with gate travel and open/close limits.
4. Install a twisted shielded 2 pair wire harness between the two operators. Match A-A, B-B, and COM-COM. Install the grounding shield on only one of the controller mounting brackets.

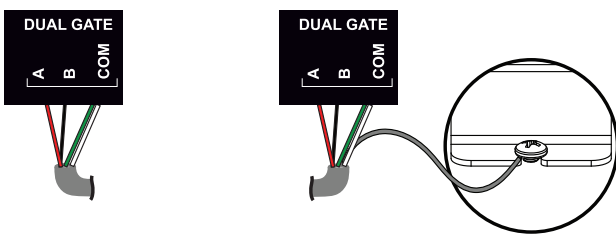

Figure 24. Dual Gate Connection

## Sequenced gate wiring:

Sequenced gate wiring is similar to dual gate wiring. Instead of the DUAL GATE terminal, use the SEQ GATE terminal. Install a twisted shielded 2 pair wire harness between the two operators. Match A-A, B-B, and COM-COM. Install the grounding shield on only one of the controller mounting brackets (Figure 25). Refer to page 48 through page 51 for loop view diagrams.

When sequenced gates are being used in barrier arm and security gate system, both operators must be set to the same loop view setting. When sequenced gates is used for a Sally Port system, then one gate must be set to Sally A and the other must be set to Sally B.

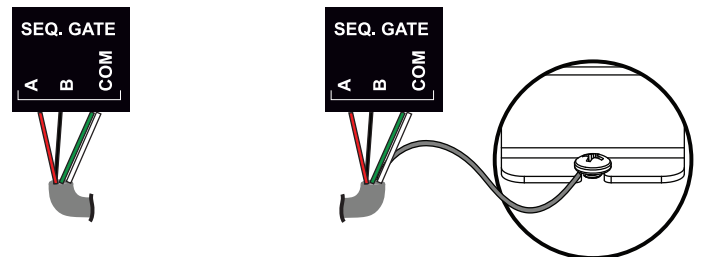

Figure 25. Sequenced Gate Connection

5. Set one operator as the primary and the other as the secondary.
6. Test the gate operation.
7. Adjust LEAF DELAY CLOSE and LEAF DELAY OPEN if required.

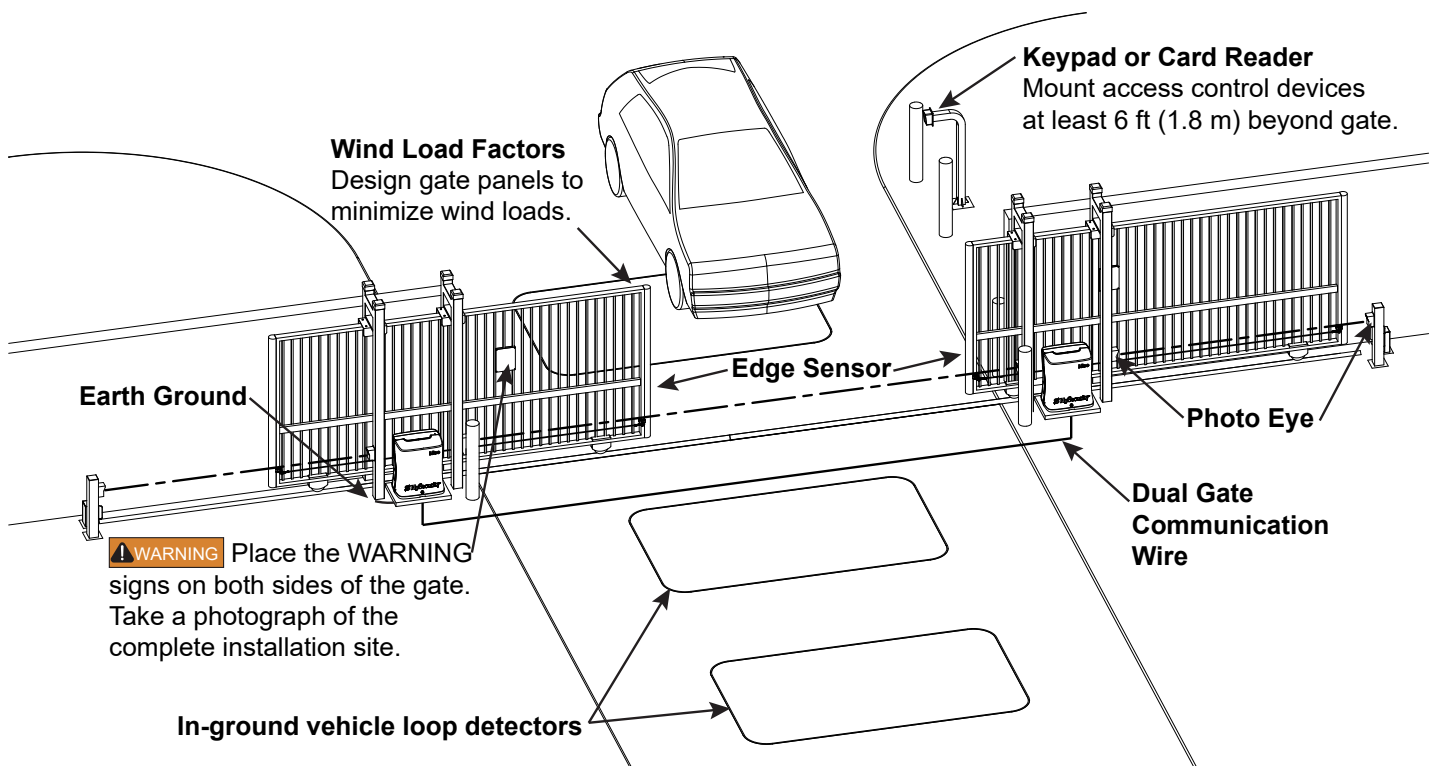

Figure 26. Bi-Parting Gate



# VEHICLE DETECTOR LOOP LAYOUTS

This slide gate site scenario depicts a bi-directional traffic system with controlled access entry (card reader, radio control, etc.) and free exit.

The gate's closure time is determined by the number of seconds entered in the CLOSE TIMER item found in the User Menu. The timer to close starts when all loops are clear. The timer is adjustable from 1 to 99 seconds.

For a single directional system, the free exit loop may be replaced by an obstruction loop (reversing loop).

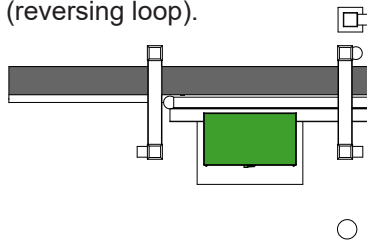

## Uni- or Bi-directional Traffic Control

Vehicles must pass from one loop to the next without loss of detection.

A = 6 ft min to 16 ft max  
(1.8 to 4.5 m)

B = 6 ft (1.8 m)

C = 3 ft min to 4 ft max  
(0.9 m to 1.2 m)

D = 3 ft min to 4 ft max  
(0.9 m to 1.2 m)

E = 4 ft min to 8 ft max  
(1.2 m to 2.4 m)

Reset Loop can be offset from C/L of gate: 1 ft to 5 ft (0.3 m to 1.5 m).

F = 10 ft to 15 ft  
(3 m to 3.6 m)

G = 4 ft to 6 ft  
(1.2 m to 2.4 m)

H = 0.7 ft (0.2 m)

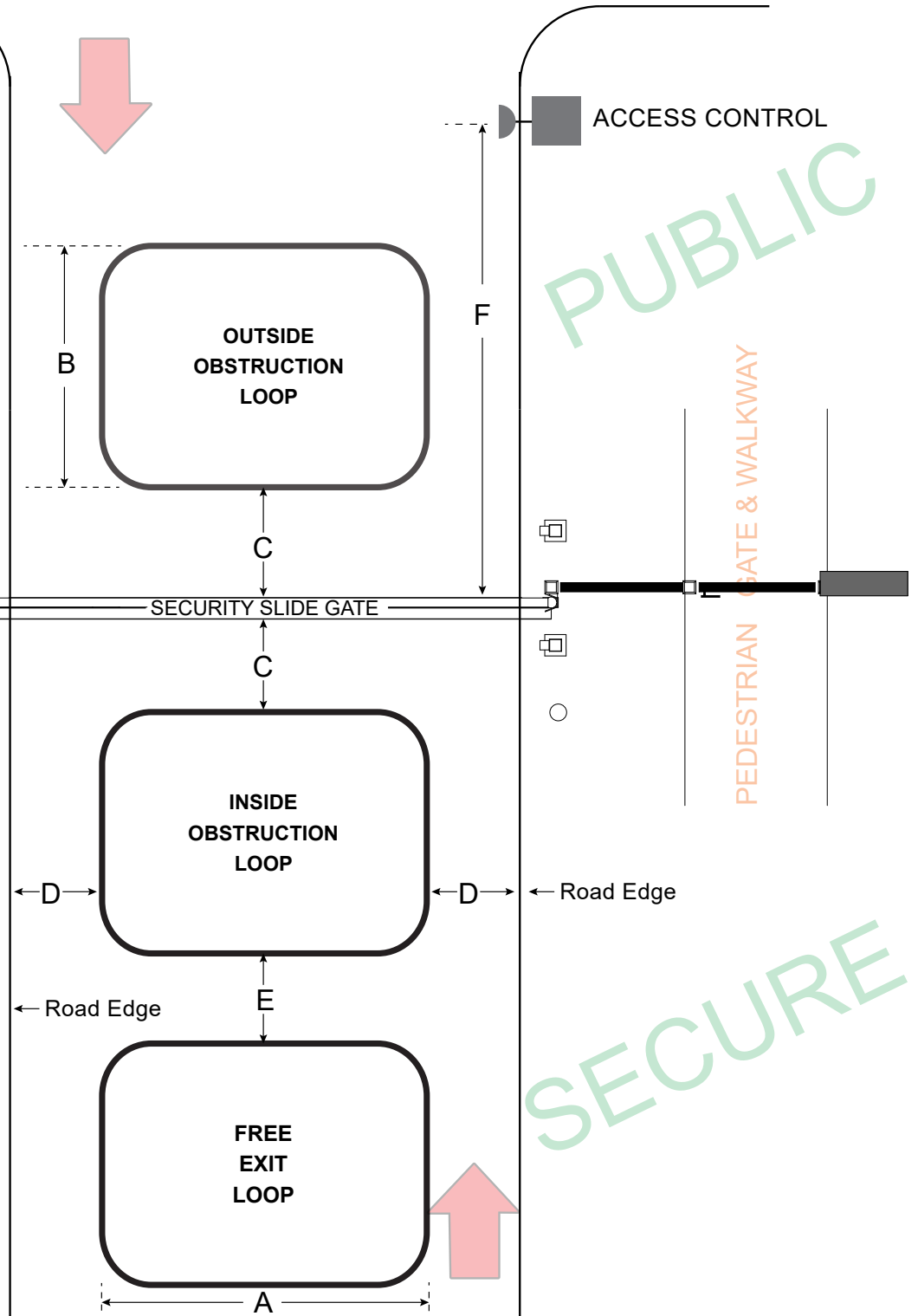

Note: A minimum of three (3) detectors are required for this type of gate site scenario. V-track gate shown; other gate types similar.

Drawings NOT to scale

# SEQUENCED GATE: LOOP VIEW #1

To sequence the gates, set the Menu item, SEQUENCED GATE to "1" in both gate operators.

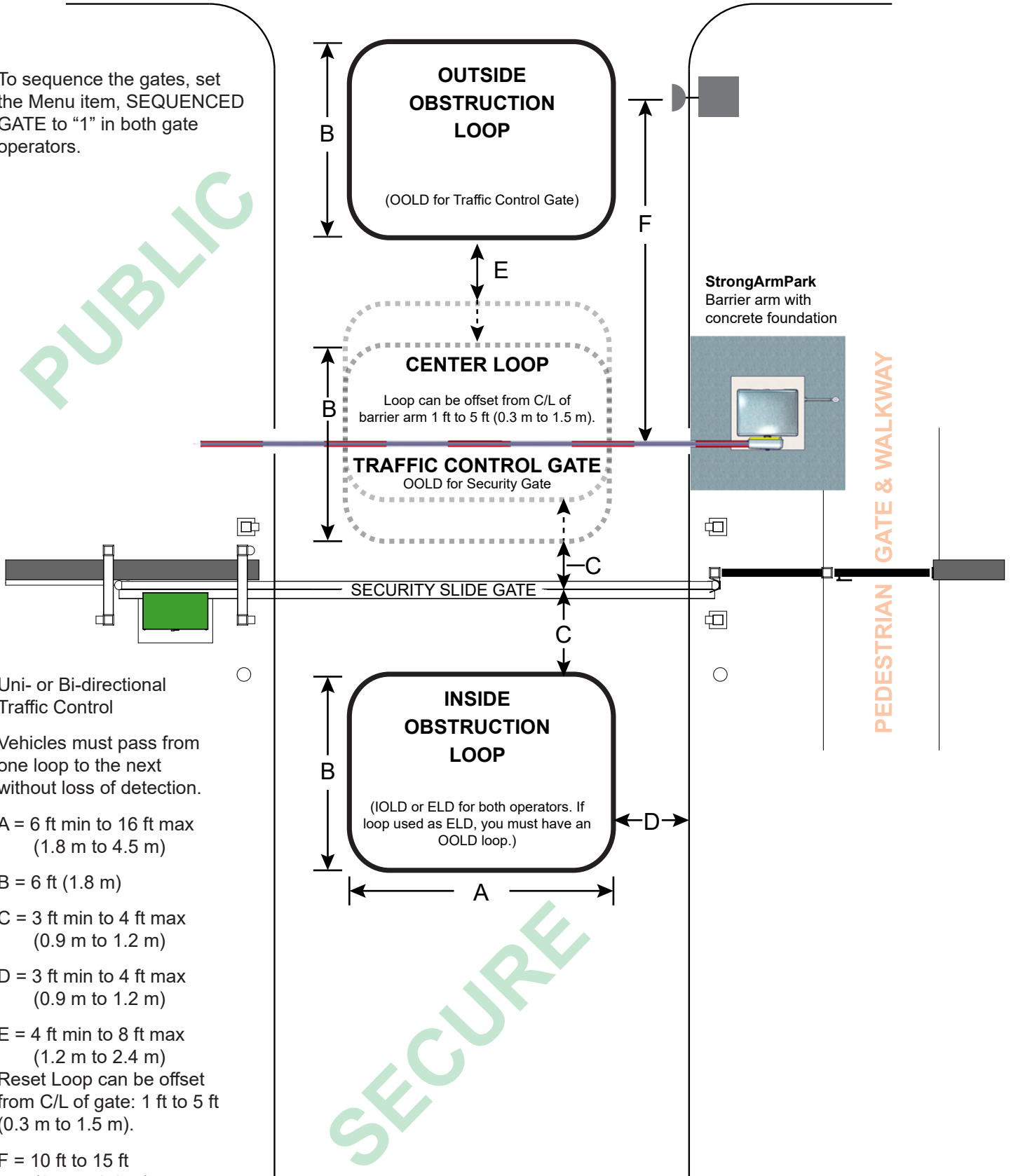

Uni- or Bi-directional Traffic Control

Vehicles must pass from one loop to the next without loss of detection.

A = 6 ft min to 16 ft max  
(1.8 m to 4.5 m)

B = 6 ft (1.8 m)

C = 3 ft min to 4 ft max  
(0.9 m to 1.2 m)

D = 3 ft min to 4 ft max  
(0.9 m to 1.2 m)

E = 4 ft min to 8 ft max  
(1.2 m to 2.4 m)

Reset Loop can be offset from C/L of gate: 1 ft to 5 ft  
(0.3 m to 1.5 m).

F = 10 ft to 15 ft  
(3 m to 3.6 m)

G = 4 ft to 6 ft  
(1.2 m to 2.4 m)

H = 0.7 ft (0.2 m)

Drawings NOT to scale

# SEQUENCED GATE: LOOP VIEW #2

To sequence the gates, set the Menu item, SEQUENCED GATE to "2" in both gate operators.

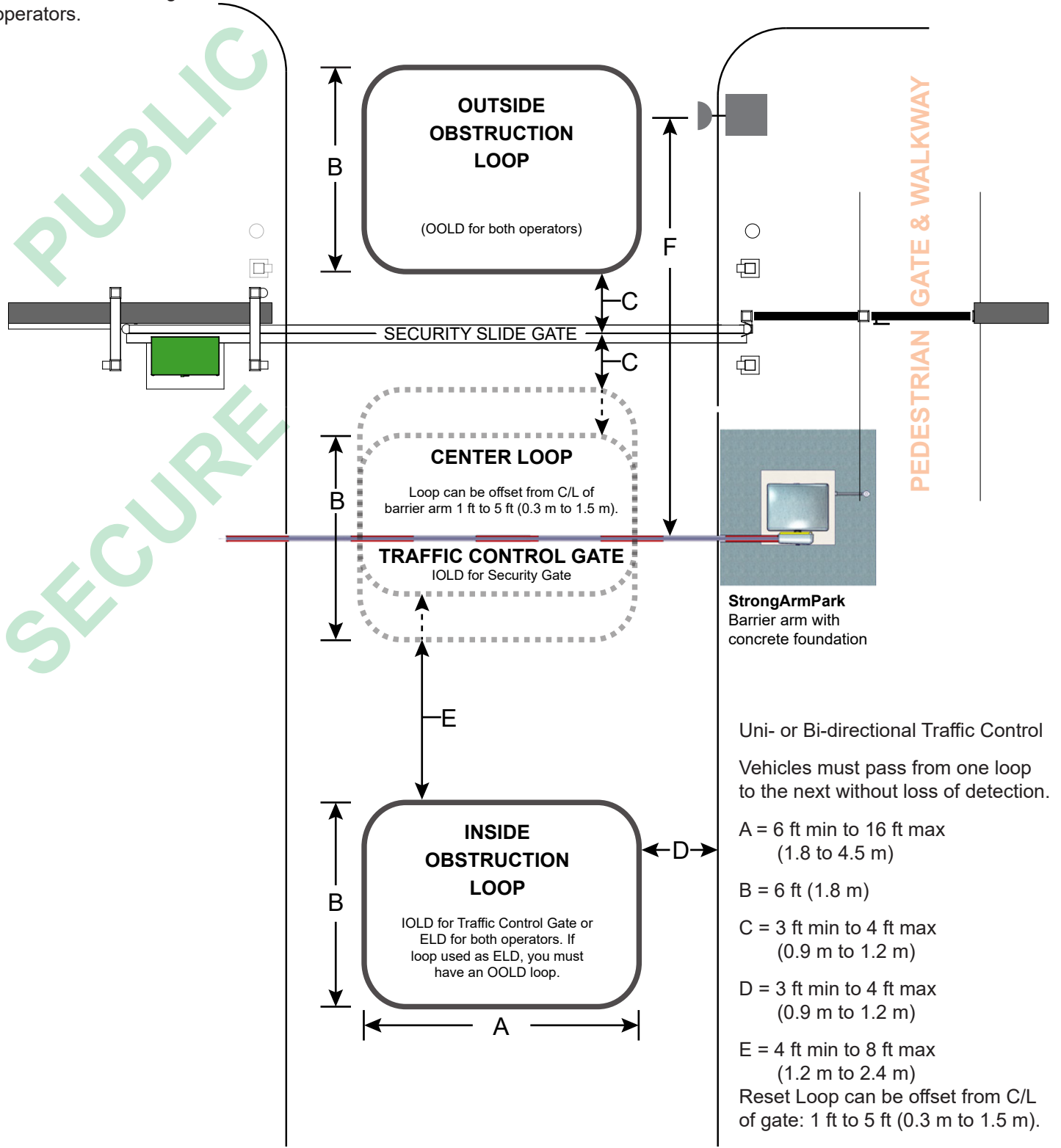

Uni- or Bi-directional Traffic Control  
Vehicles must pass from one loop to the next without loss of detection.

A = 6 ft min to 16 ft max  
(1.8 to 4.5 m)

B = 6 ft (1.8 m)

C = 3 ft min to 4 ft max  
(0.9 m to 1.2 m)

D = 3 ft min to 4 ft max  
(0.9 m to 1.2 m)

E = 4 ft min to 8 ft max  
(1.2 m to 2.4 m)

Reset Loop can be offset from C/L of gate: 1 ft to 5 ft (0.3 m to 1.5 m).

F = 10 ft to 15 ft  
(3 m to 3.6 m)

G = 4 ft to 6 ft  
(1.2 m to 2.4 m)

H = 0.7 ft (0.2 m)

Drawings NOT to scale

# SEQUENCED GATE: LOOP VIEW #3

To sequence the gates, set the Menu item, SEQUENCED GATE to "3" in both gate operators.

Uni- or Bi-directional Traffic Control

Vehicles must pass from one loop to the next without loss of detection.

A = 6 ft min to 16 ft max  
(1.8 to 4.5 m)

B = 6 ft (1.8 m)

C = 3 ft min to 4 ft max  
(0.9 m to 1.2 m)

D = 3 ft min to 4 ft max  
(0.9 m to 1.2 m)

E = 4 ft min to 8 ft max  
(1.2 m to 2.4 m)

Reset Loop can be offset from C/L of gate: 1 ft to 5 ft  
(0.3 m to 1.5 m).

F = 10 ft to 15 ft  
(3 m to 3.6 m)

G = 4 ft to 6 ft  
(1.2 m to 2.4 m)

H = 0.7 ft (0.2 m)

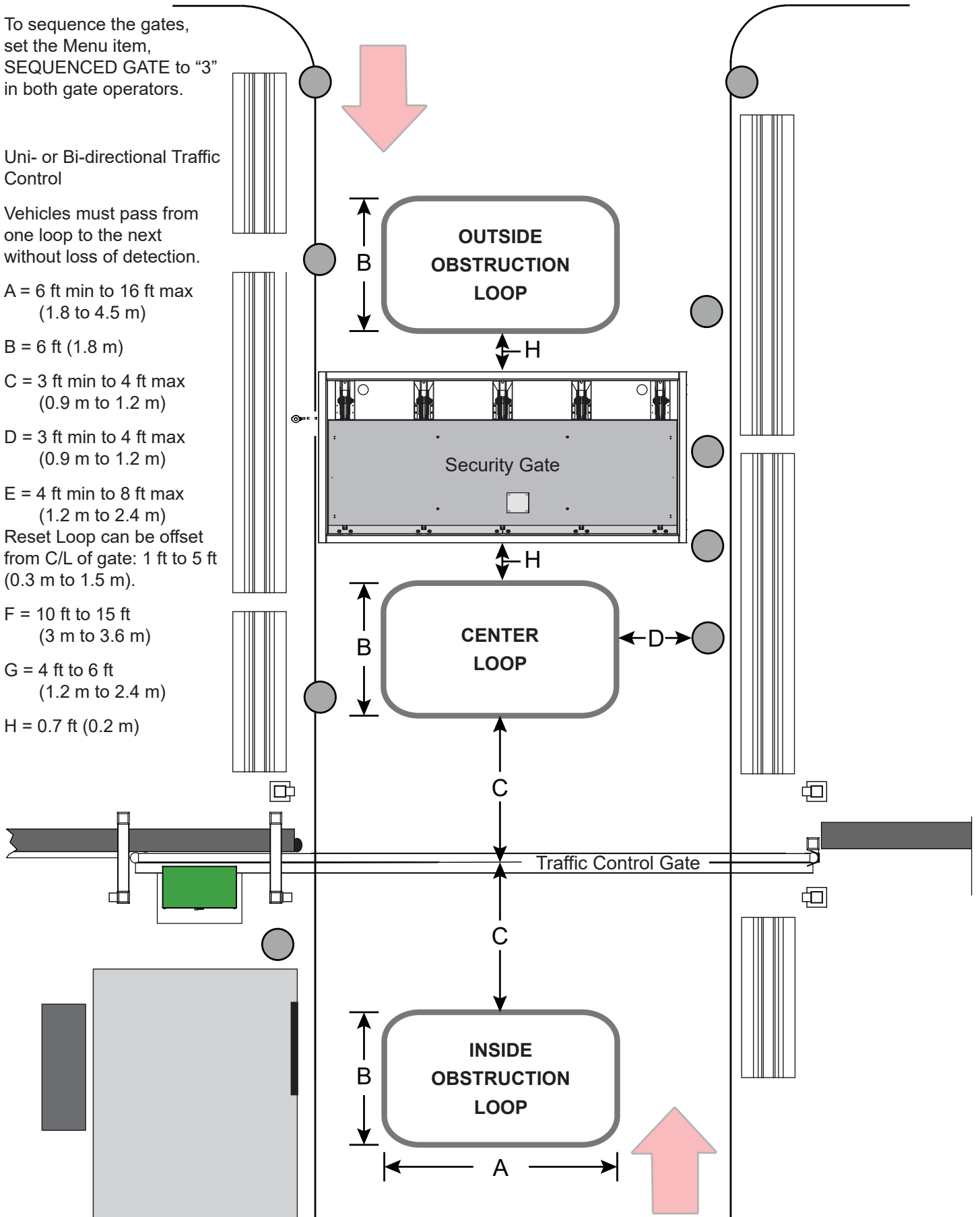

Drawings NOT to scale

# SEQUENCED GATE: LOOP VIEW #4

To sequence the gates, set the Menu item, SEQUENCED GATE to "4" in both gate operators.

Uni- or Bi-directional Traffic Control

Vehicles must pass from one loop to the next without loss of detection.

A = 6 ft min to 16 ft max  
(1.8 to 4.5 m)

B = 6 ft (1.8 m)

C = 3 ft min to 4 ft max  
(0.9 m to 1.2 m)

D = 3 ft min to 4 ft max  
(0.9 m to 1.2 m)

E = 4 ft min to 8 ft max  
(1.2 m to 2.4 m)

Reset Loop can be offset from C/L of gate: 1 ft to 5 ft  
(0.3 m to 1.5 m).

F = 10 ft to 15 ft  
(3 m to 3.6 m)

G = 4 ft to 6 ft  
(1.2 m to 2.4 m)

H = 0.7 ft (0.2 m)

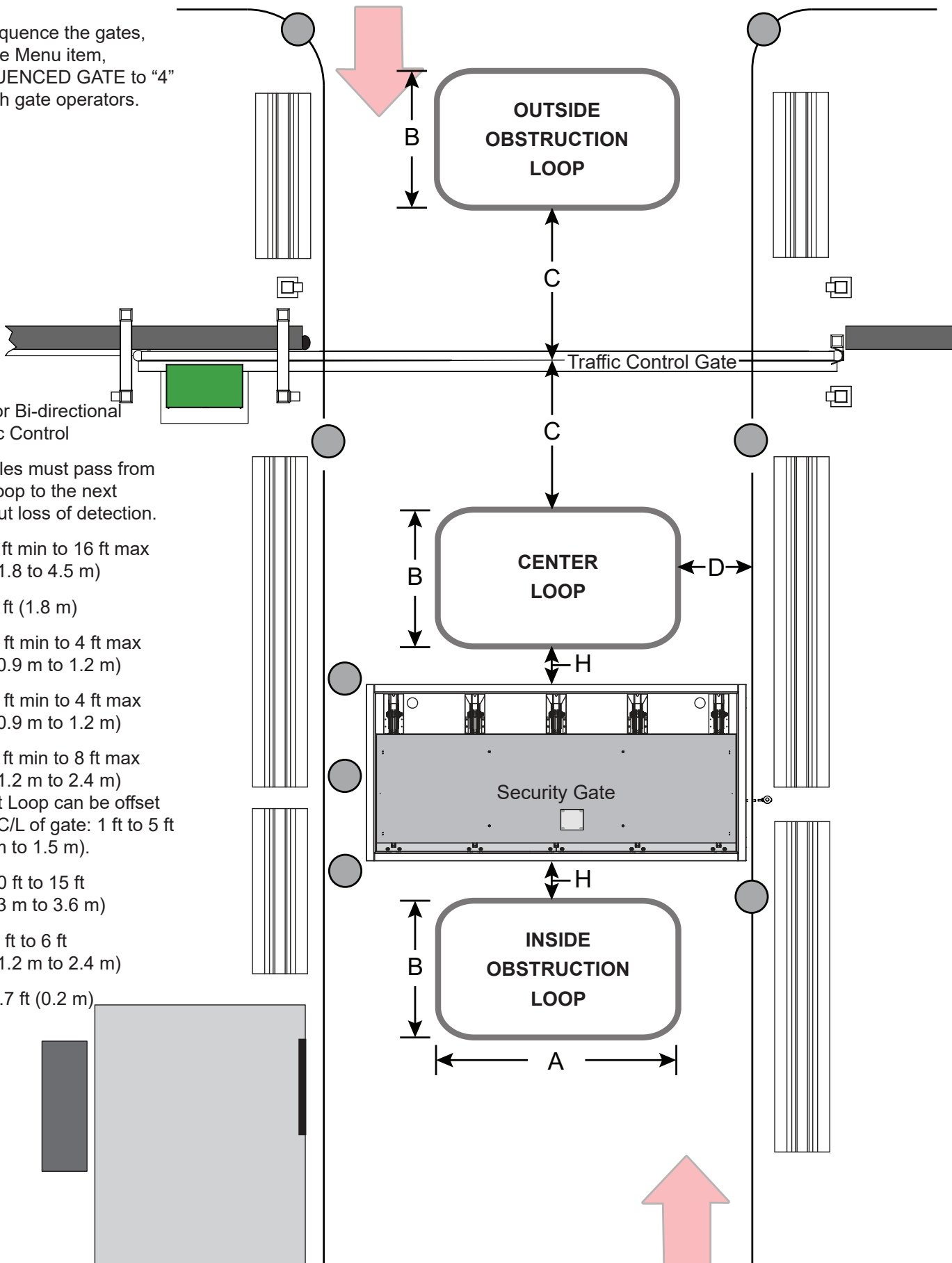

Drawings NOT to scale

# PROGRAMMABLE INPUTS

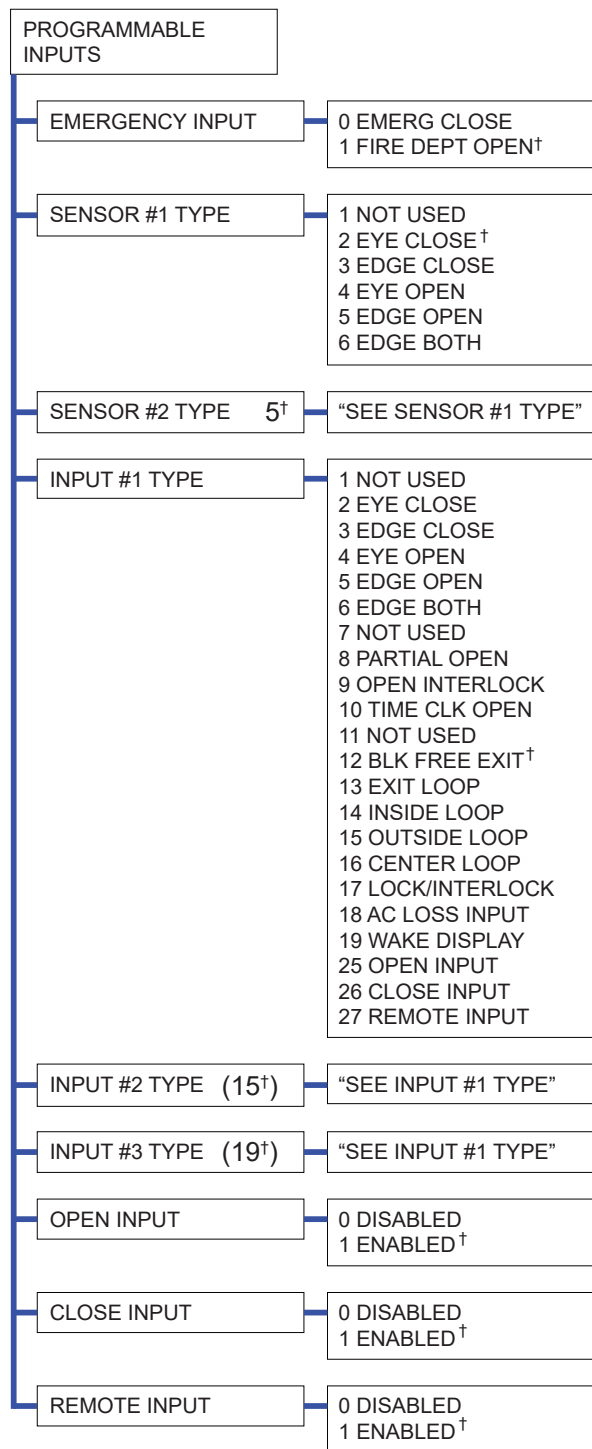

† = Indicates default

# PROGRAMMABLE INPUTS

**Table 10. SmartTouch 720/725 Programmable Inputs Settings**

MENU DISPLAY	SETTINGS	DESCRIPTION
EMERGENCY INPUT	0 = EMERG CLOSE 1 = FIRE DEPT OPEN†	Activation of this input requires a +24VDC signal. Defaults to Fire Department Open input. When set to 1, signal received through this input overrides all photoelectric eyes and edge sensors and opens gate. Pressing RESET button (or the OPEN or the STOP button) is required before gate can be closed. When set to 0, the input can be used as an Emergency Close.
SENSOR #1 TYPE	1 = NOT USED 2 = EYE CLOSE† 3 = EDGE CLOSE 4 = EYE OPEN 5 = EDGE OPEN	Monitored input per UL325 requirements for connection of external entrapment sensors - contact (edge sensor) or non-contact (photo eye). Edge Both is only available in Swing Gate operator types.
SENSOR #2 TYPE	SAME SETTINGS AS SENSOR #1 TYPE 5 = EDGE OPEN†	Same as Sensor #1 Type
INPUT #1 TYPE	1 = NOT USED 2 = EYE CLOSE 3 = EDGE CLOSE 4 = EYE OPEN 5 = EDGE OPEN 6 = EDGE BOTH (SWING ONLY) 7 = NOT USED 8 = PARTIAL OPEN (SLIDE ONLY) 9 = OPEN INTERLOCK 10 = TIME CLK OPEN 11 = NOT USED 12 = BLK FREE EXIT† 13 = EXIT LOOP 14 = INSIDE LOOP 15 = OUTSIDE LOOP 16 = CENTER LOOP 17 = LOCK/INTERLOCK 18 = AC LOSS INPUT 19 = WAKE DISPLAY 25 = OPEN INPUT 26 = CLOSE INPUT 27 = REMOTE INPUT	When set to 2-6, this input will be monitored and requires connection of an external sensor's 10K or 4-wired pulsed output. The common terminal for a monitored sensor must be connected to the switched common at the Sensor 1 or Sensor 2 input.
INPUT #2 TYPE	SAME SETTINGS AS INPUT #1 TYPE 15 = OUTSIDE LOOP	Same as Input #1 Type
INPUT #3 TYPE	SAME SETTINGS AS INPUT #1 TYPE (2-6 not applicable) 19 = WAKE DISPLAY	Same as Input #1 Type
OPEN INPUT	0 = DISABLED 1 = ENABLED†	Option to fully disable OPEN INPUT. Can be used to troubleshoot active input alerts.
CLOSE INPUT	0 = DISABLED 1 = ENABLED†	Option to fully disable CLOSE INPUT. Can be used to troubleshoot active input alerts.
REMOTE INPUT	0 = DISABLED 1 = ENABLED†	Option to fully disable REMOTE INPUT. Can be used to troubleshoot active input alerts.



# CONTROLLER INPUTS

SmartTouch 720/725 Controller Input Examples Only

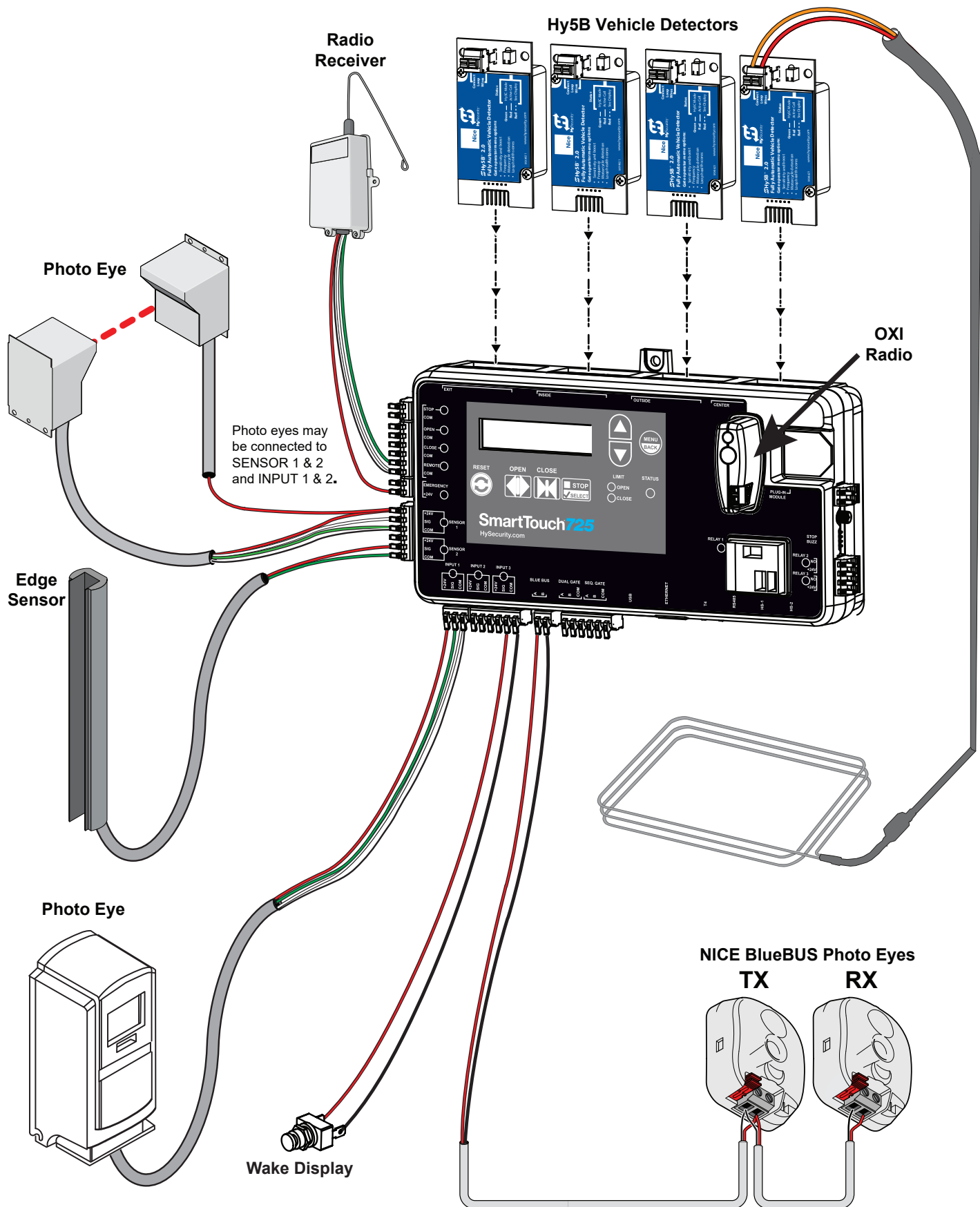

# ENTRAPMENT SENSOR WIRING - BLUEBUS

## Install a BlueBUS photo eye:

1. Verify the jumpers on transmitter (TX) and receiver (RX) are in the same positions (Figure 27).
2. Install the BlueBUS photo eyes in appropriate locations for entrapment protection (page 8).
3. Set the power switch to OFF.
4. Route the wires to the inside of the SlideDriver II chassis.
5. Install the wires between the TX and RX and then into BlueBUS terminals on the SmartTouch 725 Controller (Figure 31).

Note: With BlueBUS technology there are 4 total close direction pairs and 2 open direction pairs available. Pairs may either be connected in parallel to one another or directly to the SmartTouch 725 Controller.

6. Set power switch to ON.
7. In EXTERNAL COMMUNICATIONS MENU, select BLUEBUS OPTIONS MENU, and set SCAN FOR DEVICES to 1 (ON).

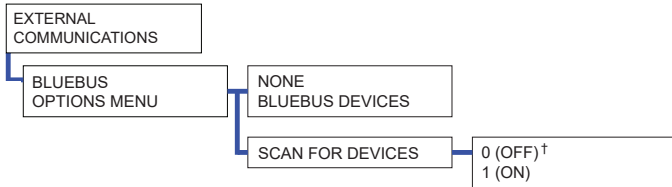

8. Display will show EYE CLOSE BlueBUS P1 or the P# for the jumper configuration used.
9. In ENTRAPMENT SENSOR RESPONSE menu, set the desired response action for each entrapment type.
10. Test the function of each sensor pair.

BlueBUS RX LED Status Light	Status
Off	No power
3 flashes, pause, repeat	Controller has not memorized the pair
Slow flashes	Good signal
Fast flashes	Weak signal
Always on	No signal

Direction	Pair	Jumper Positions (Pairs must match)
CLOSE	P1	
CLOSE	P2	
CLOSE	P3	
CLOSE	P4	
OPEN	P5	
OPEN	P6	

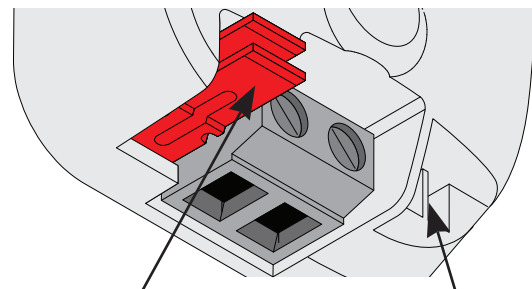

Example jumper position Jumper storage Close P1

Figure 27. BlueBUS and Jumper Designation

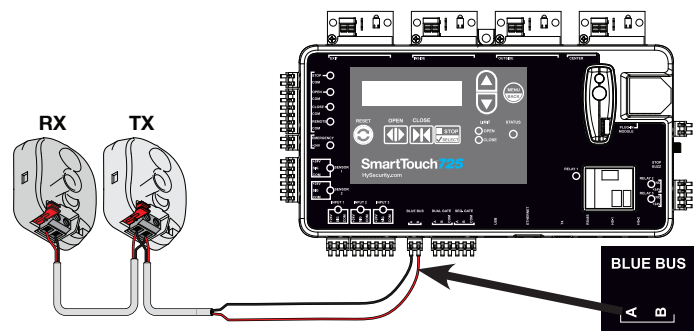

NOTE: Matching wire polarity is not required for BlueBUS photocells.

NOTE: Jumper locations shown here are for a CLOSE P1 installation.

Figure 28. Connect the BlueBUS Photo Eye

† = Indicates default

# ENTRAPMENT SENSOR WIRING

HySecurity provides one edge sensor typically used as hardwired EDGE OPEN and one photo eye typically used as EYE CLOSE with the SlideDriver II 15, 40, 50F, and 80V.

## Install the entrapment sensor:

1. Set power switch to OFF.
2. Install the entrapment sensor in an appropriate location for entrapment protection (page 8).
3. Route the wires to the inside of the SlideDriver II chassis.
4. Install the wires into input Sensor #1, Sensor #2, or Input #1, Input #2, or Input #3 on the SmartTouch 720/725 Controller (Figure 29).

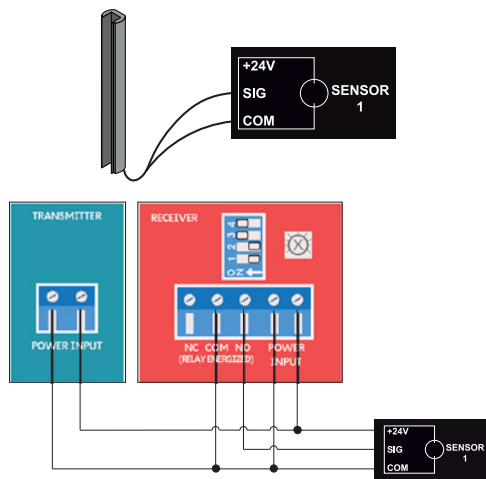

Figure 29. Bundled Sensor Connections

5. Set power switch to ON.
6. In PROGRAMMABLE INPUTS menu, select the SENSOR TYPE or INPUT TYPE for each external entrapment sensor. The indicator LED changes to green when sensor is activated or not installed correctly.
7. In ENTRAPMENT SENSOR RESPONSE menu, set the desired response action for each entrapment type.
8. Test the function of each sensor.

## Install a non-BlueBUS photo eye:

Additional photo eyes can connect to the SmartTouch 720/725 Controller terminals Sensor #1 - #2 and Input #1 - #3. Follow the instructions for entrapment sensors (Figure 6).

Set any DIP-switches and jumpers according to manufacturer instructions for 10k output.

Make sure to connect to a Sensor COM port for switched common for monitoring purposes.

† = Indicates default

PROGRAMMABLE INPUTS	
EMERGENCY INPUT	0 EMERG CLOSE 1 FIRE DEPT OPEN †
SENSOR #1 TYPE	1 NOT USED † 2 EYE CLOSE † 3 EDGE CLOSE 4 EYE OPEN 5 EDGE OPEN 6 EDGE BOTH
SENSOR #2 TYPE (5†)	"SEE SENSOR #1 TYPE"
INPUT #1 TYPE	1 NOT USED 2 EYE CLOSE 3 EDGE CLOSE 4 EYE OPEN 5 EDGE OPEN 6 EDGE BOTH 7 NOT USED 8 PARTIAL OPEN 9 OPEN INTERLOCK 10 TIME CLK OPEN 11 NOT USED 12 BLK FREE EXIT † 13 EXIT LOOP 14 INSIDE LOOP 15 OUTSIDE LOOP 16 CENTER LOOP 17 LOCK/INTERLOCK 18 AC LOSS INPUT 19 WAKE DISPLAY 25 OPEN INPUT 26 CLOSE INPUT 27 REMOTE INPUT
INPUT #2 TYPE (15†)	"SEE INPUT #1 TYPE"
INPUT #3 TYPE (19†)	"SEE INPUT #1 TYPE"
OPEN INPUT	0 DISABLED 1 ENABLED †
CLOSE INPUT	0 DISABLED 1 ENABLED †
REMOTE INPUT	0 DISABLED 1 ENABLED †

ENTRAPMENT SENSOR RESPONSE	
IES SENSITIVITY (2†)	0 (MAXIMUM) - 9
PHOTO EYE ALIGN	0 (OFF) † 1 (ON)
EDGE CLOSE LOGIC	0 FULL OPEN † 1 REVERSE 2S
EYE CLOSE LOGIC	0 STOP ONLY † 1 REVERSE 2S 2 FULL OPEN
EYE OPEN LOGIC	0 STOP ONLY † 1 REVERSE 2S
IES STOP ONLY	0 (OFF) † 1 (ON)
REVERSAL LOGIC	0 FULL OPEN † 1 REVERSE 2S

Note: When Photo Eye Align mode is turned on, the display will show all the sensor inputs that are programmed for photo eyes and will show if they are active or not (a 1 indicates the eye is present and aligned and a 0 indicates the eye is not aligned or blocked). Any BlueBUS eye will also show up on the display.

# LIST OF ENTRAPMENT SENSORS

## ENTRAPMENT SENSORS COMPATIBLE WITH HYSECURITY OPERATORS

### NOTICE

The SmartTouch 720/725 Controller inputs use 10k or 4-wire pulsed monitoring. Connect sensor using sensor instructions for the compatible output connections. The SmartCNX and SmartTouch 720/725 Controllers do not support normally closed inputs.

**Table 11. Sensors Tested for Use with HySecurity Operators**

	Mfg. Part # or Model	Brand	Nice   Hysecurity Part #	Max Range	Smart Touch	Smart DC	SmartCNX / SmartTouch 725	1050	Mercury 310
<b>Photo Eyes (Retro-reflective)</b>	E3K-R10K4-NR-1	Omron	MX000999	40 ft	•	•	•		
	NIR-50-325	EMX	-	45 ft	•	•	•	•	•
	IRB-RET	EMX	-	53 ft	•	•	•	•	•
	E-931-S50RRGQ	Seco-Larm	-	46 ft	•	•	•		•
<b>Photo Eyes (Thru-Beam)</b>	Blue Bus Era Photo Eyes	Nice   HySecurity	EPMB/A EPMOB/A EPLOB/A EPMAB/A EMBORB/A	45 ft			•	•	•
	OVS-50TNR	Optex	-	33 ft	•	•			
	IRB-MON*	EMX	MX3990	65 ft	•	•	•		•
	E-960-D90GQ	Seco-Larm	-	90 ft	•	•	•		•
<b>Edge Sensors</b>	Sentir Series**	ASO Safety	"AS1502-* AS1501-**"		•	•	•	•	•
	CPT210-2U-#-T2	Miller Edge	-		•	•	•	•	•
<b>Edge Sensor Converters</b>	Hy2NC (Converts 10K to NC Monitoring)	HySecurity	MX4018		•	•			
	GEM103 (Converts 10K to Pulsed Monitoring)	Miller Edge	-					•	
<b>Edge Wireless Kits</b>	iGAZE RE Kit	Transmitter Solutions	-		•	•	•	•	•
	WEL-200	EMX	-		•	•	•	•	•
<b>Multi-Input Module</b>	The Solution – MIM-62	Miller Edge	-		•	•	•		•

The following examples show wiring to SENSOR 1, but one can also make these connections to SENSOR 2 as well as INPUT 1-2. Remember to change the setting for the SENSOR or INPUT terminal to match the connected device. Reference the manufacturer's installation instructions for help with programming or other setup issues.

### Omron E3K-R10K4-NR-1 (Photo Eye)

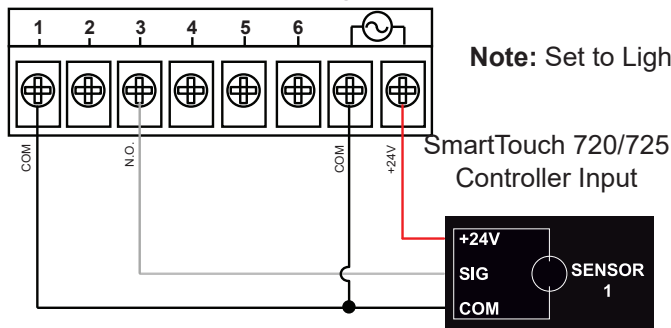

Figure 30. Omron E3K

# APPROVED SENSOR WIRING

## EMX IRB-RET (Photo Eye)

NOTE: Set board as shown in red boxes per Figure 31. Jumpers are three pin type, and placed LEFT or RIGHT as indicated.

### DIAGRAM A: 10K OHM RESISTIVE WIRING

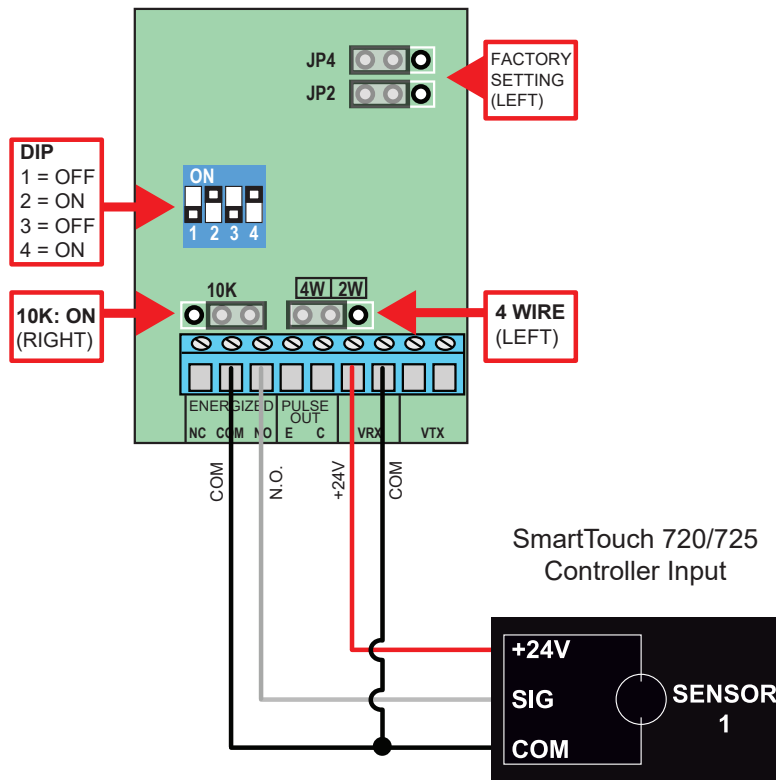

### DIAGRAM B: 4-WIRE PULSED WIRING

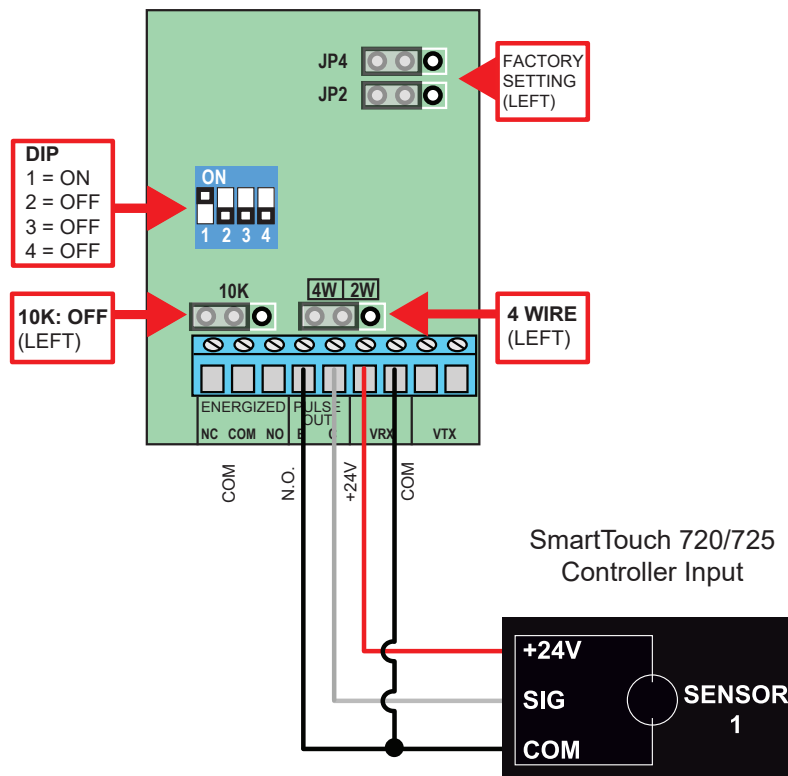

Figure 31. EMX IRB-RET Wiring - 10K OHM Resistive (Top) and 4-Wire Pulsed (Bottom)

## Seco-Larm Enforcer Retro-Reflective (E-931-S50RRGQ) (Photo Eye)

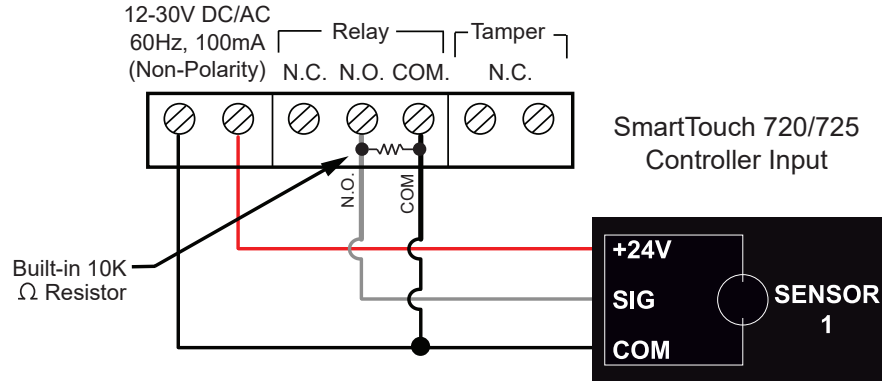

Figure 32. Seco-Larm Enforcer Retro-Reflective (E-931-S50RRGQ)

## Seco-Larm Enforcer Through-Beam (E-960-D90GQ)

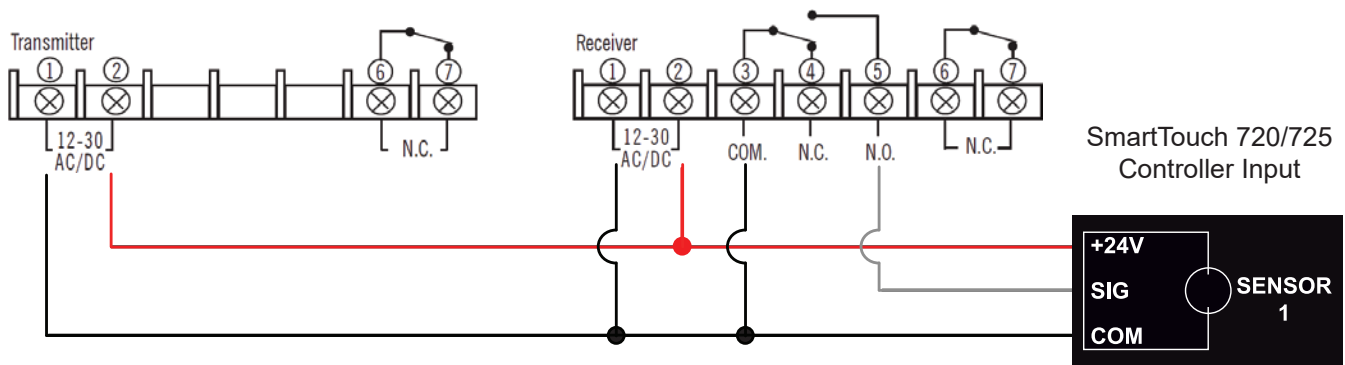
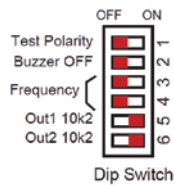

Figure 33. Seco-Larm Enforcer Through-Beam (E-960-D90GQ)

## Transmitter Solutions iGaze RE Kit (Photo Eye)



**NOTE:** Dashed lines indicate the secondary wiring connections if an additional SmartTouch 720/725 sensor input is wired to the sensor. See manufacturer's instructions for details.

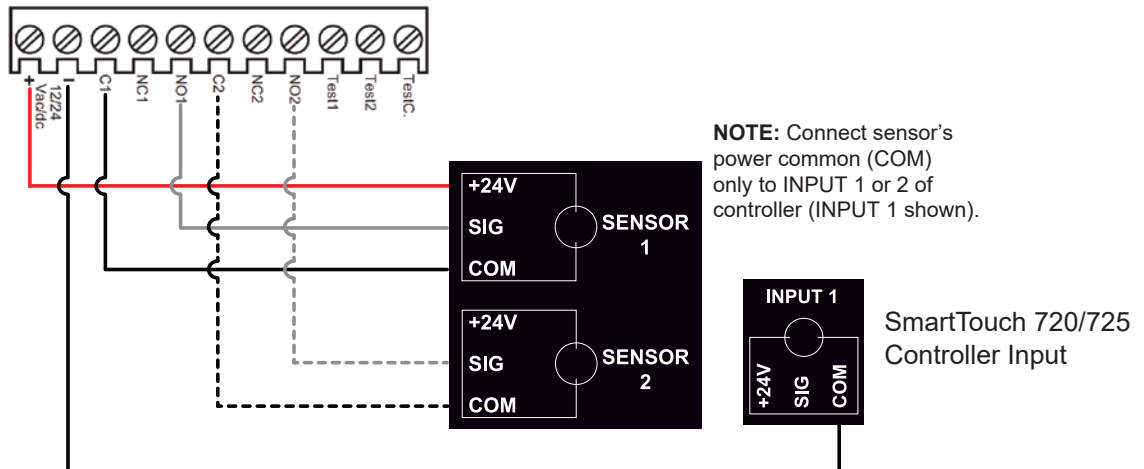

Figure 34. Transmitter Solutions iGaze RE Kit

# APPROVED SENSOR WIRING

## EMX WEL200 (Edge Sensor)

**NOTE:** Set board as shown in red boxes per Figure 35 for desired configuration. Jumpers are three pin type, and placed UPPER or LOWER as indicated. Dashed lines indicate the secondary wiring connections if an additional SmartTouch 720/725 sensor input is wired to the sensor. See manufacturer's instructions for details.

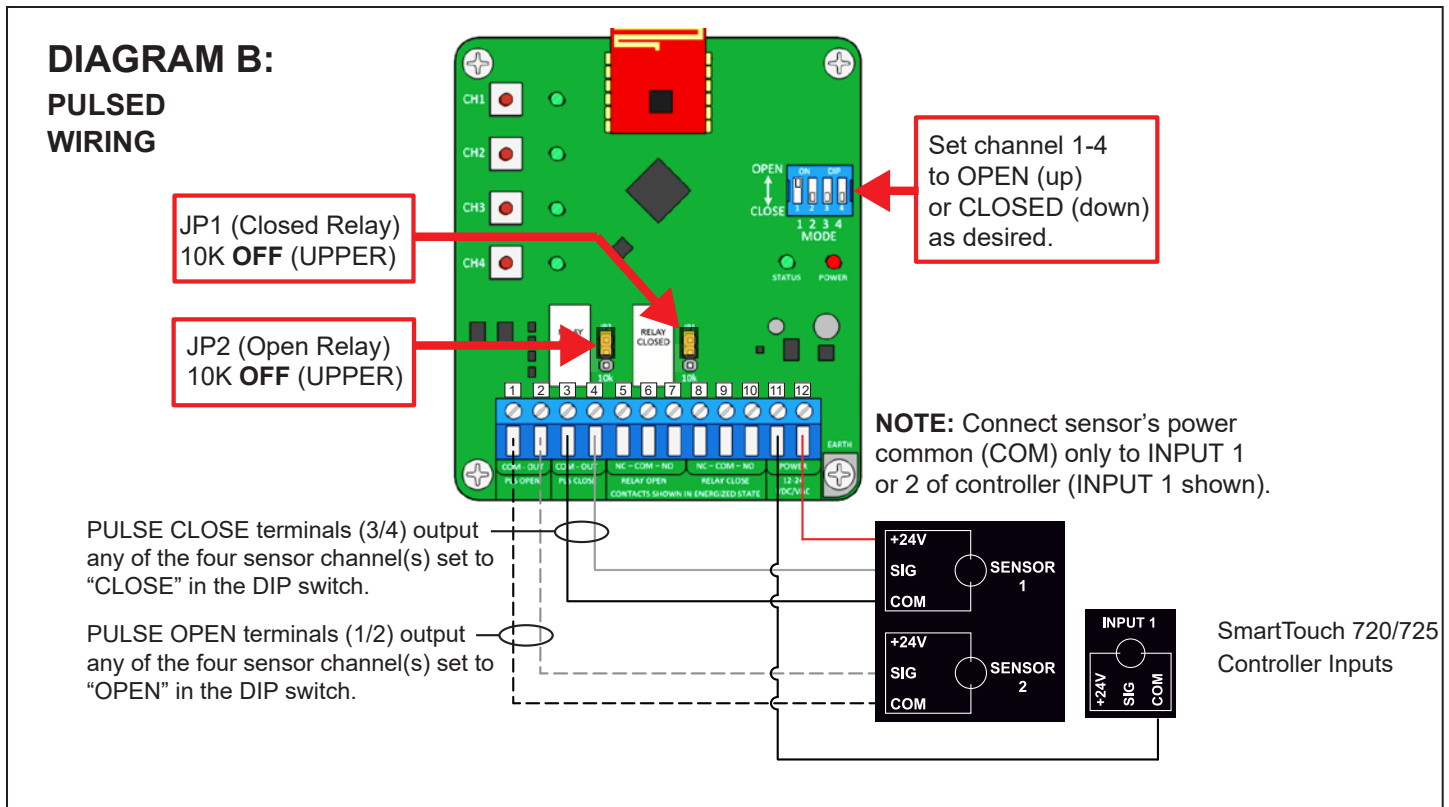
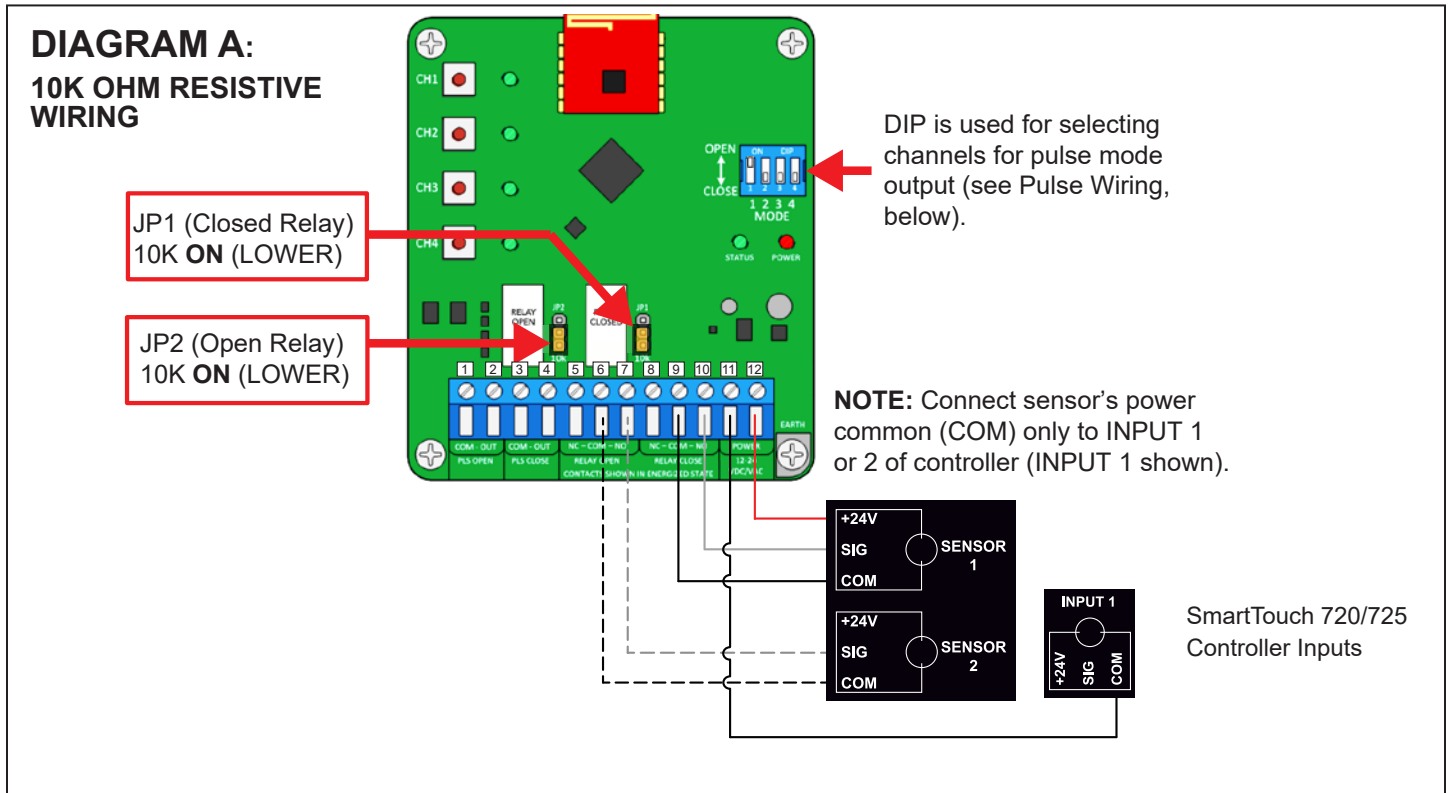

Figure 35. EMX WEL200 Wiring



## EMX NIR-50-325 (Photo Eye)

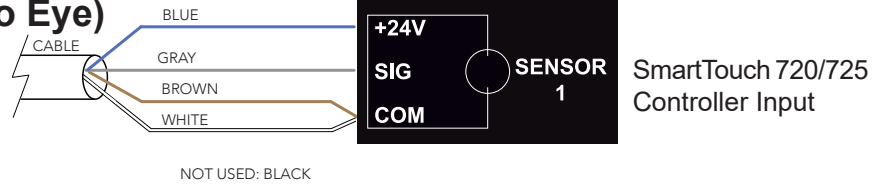
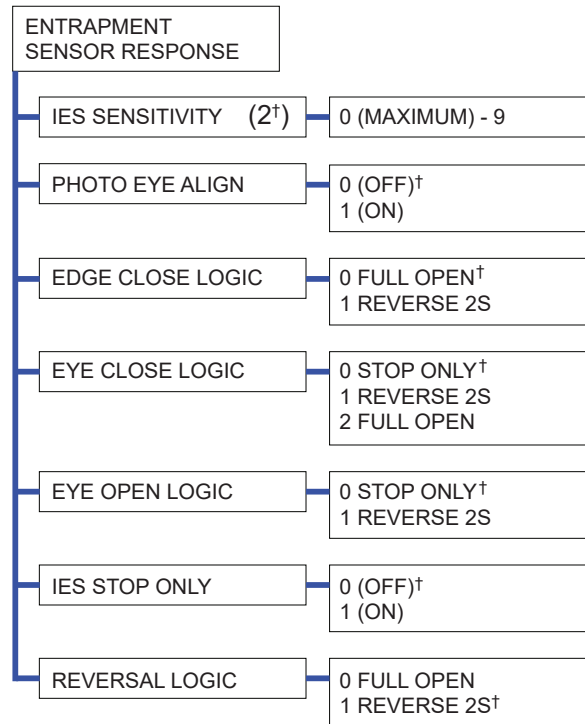

Figure 36. EMX NIR-50-325

Note: There is a difference between input and sensor COMs. When programmed for an entrapment sensor both will be monitored during gate travel. When there is no AC power present, Sensor COMs switch off while the gate is stopped and Input COMs are always on.

# ENTRAPMENT SENSOR RESPONSE

---



† = Indicates default

# ENTRAPMENT SENSOR RESPONSE

**Table 12. SmartTouch 720/725 Operator Configurations Settings**

MENU DISPLAY	SETTINGS	DESCRIPTION
IES SENSITIVITY	0 (MAXIMUM) 1 2 (DEFAULT) <sup>†</sup> ... 9 (MINIMUM)	Adjusts the sensitivity of the internal inherent entrapment sensor (IES). Available settings are 0 to 9 with 0 being the most sensitive. HySecurity strongly recommends that you avoid setting the IES sensitivity higher than 6.  <b>NOTE:</b> Before changing the IES sensitivity, make sure that the gate moves smoothly without obstruction. Fix any issues with gate hardware.
PHOTO EYE ALIGN	0 = OFF <sup>†</sup> 1 = ON	When set to 1, operator assists photo eye alignment. Buzzer chirps once when transmitter and receiver are not aligned. When transmitter and receiver are aligned, buzzer chirps twice. If they go out of alignment again or if beam is blocked, buzzer will chirp once.  Also, when set to 1, the display will show all the sensor inputs that are programmed for photo eyes and will show if they are active or not (a 1 indicates the eye is present and aligned and a 0 indicates the eye is not aligned or blocked). Any BlueBUS eye will also show up on the display.  PHOTO EYE ALIGN changes to OFF on the next limit contact, reset, or power cycle.
EDGE CLOSE LOGIC	0 = FULL OPEN <sup>†</sup> 1 = REVERSE 2S	Default setting is a full-open reversal if gate edge close or edge both is triggered while closing. Optional setting of 1 causes gate to reverse for two seconds if triggered while closing. Gate Edge Open will reverse to full close when all open inputs and loop detectors are not active. There is no adjustment to gate edge open reversal.
EYE CLOSE LOGIC	0 = STOP ONLY <sup>†</sup> 1 = REVERSE 2S 2 = FULL OPEN	Default setting is non-reversal if photo eye close is triggered while closing. A setting of 1 causes gate to reverse toward open for two seconds if triggered while closing. A setting of 2 reverses the gate to full open.
EYE OPEN LOGIC	0 = STOP ONLY <sup>†</sup> 1 = REVERSE 2S	Default setting is non-reversal if photo eye open is triggered while opening. A setting of 1 causes gate to reverse travel and close for two seconds if triggered while opening.
IES STOP ONLY	0 = OFF <sup>†</sup> 1 = ON	In a Usage Class 4 environment, operator can be set to stop gate and not reverse gate travel after an IES trip.
REVERSAL LOGIC	0 = FULL OPEN 1 = REVERSE 2S <sup>†</sup>	Sets the reversal logic for IES response. Default is reverse for 2 seconds. Set to 0 for full open.

# IES SENSITIVITY AND WIND LOAD FACTOR

To comply with UL 325 Safety Standards, SlideDriver II operators are equipped with a Type A, Inherent Entrapment Sensor (IES). The firmware monitors the hydraulic pressure when a gate is in motion and reverses direction of gate travel when the pressure exceeds a self-adapting threshold. A spike in hydraulic pressure can be caused by the gate hitting a pedestrian, a collision with a vehicle, failing gate hardware, extreme wind gust, or any other force applied against the moving gate. To set the IES sensitivity for your site follow these instructions:

1. Press MENU on the SmartTouch 720/725 Controller.
2. Press the UP or DOWN arrow to navigate to ENTRAPMENT SENSOR RESPONSE, press SELECT.
3. Press the UP or DOWN arrow to navigate to IES SENSITIVITY, press SELECT.
4. Press the UP or DOWN arrow to choose an IES SENSITIVITY, press SELECT to update the setting.
5. Press BACK until the display shows the operator status.
6. Run the operator for 3 uninterrupted gate cycles so the IES can adapt to the new setting.
7. Apply force to the leading edge of the moving gate with an immovable obstruction to trigger the IES. Gate will stop motion and reverse for at least two seconds. "SAFE MODE" appears on the display.

## WARNING

Do not enter the path of gate travel to test IES sensitivity. Vehicular gate operators must by their nature be powerful to function reliably. This power can cause injury or death to people caught in the moving gate.

8. Cycle the gate a few times to test the IES sensitivity.

Note: The default IES SENSITIVITY of 2 should be sufficient for most sites.

Note: In Safe Mode, the automatic close timer is disabled, but any open or close input restarts gate motion. Safe Mode clears when full travel reached or Reset button pushed.

Note: A second IES trip before Safe Mode is cleared, results in an Entrapment Mode Alert which can be cleared with a Reset on the display, an open input, stop input, or stop button on SlideDriver II cover.

ENTRAPMENT  
SENSOR RESPONSE



IES SENSITIVITY



0 (MOST SENSITIVE) - 9

## WIND LOAD FACTORS & SITE PREP

Wind load is always a factor when considering the appropriate gate for a particular site. Solid gate panels produce a larger wind load than gates with slats or open decorative features. If you are installing a gate operator in a high wind area, gate design will affect the load on the gate operator because wind load acts the same as an obstruction. Good gate panel design presents a low surface area to reduce the wind load.

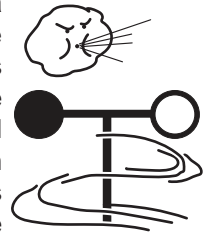

If gate is heavy and near weight capacity of what the gate operator can handle (see specifications), make sure it has an open design that allows wind to flow through it. A solid or semi-solid gate design under certain wind load conditions may cause damage to gate operator and is not covered by the HySecurity Limited Warranty.

Several factors play into calculations of wind load on a gate panel. To find out maximum wind speed in areas around the United States, search for US government wind speed maps on the internet. If you don't know how to calculate for wind load, ask a mechanical engineer or site architect for assistance prior to installing gate operator and gate panels.

When the IES trips, it sends a signal to gate operator to stop and reverse direction. This feature may be falsely triggered in excessively windy conditions because wind itself, acting over surface area of gate panel, can provide necessary force to trigger IES.

## CAUTION

Do not adjust IES sensitivity to accommodate for inappropriately designed gate panels. Loss of IES sensitivity increases mechanical wear on gate hardware and gate operator. It may also pose a safety hazard. Compensating for wind loads by adjusting IES may set IES sensitivity to a level which, when encountering an obstruction, ignores obstruction and fails to reverse direction. For more information, refer to Adjusting the IES Sensitivity.

Page intentionally left blank.

# USER RELAY OUTPUTS

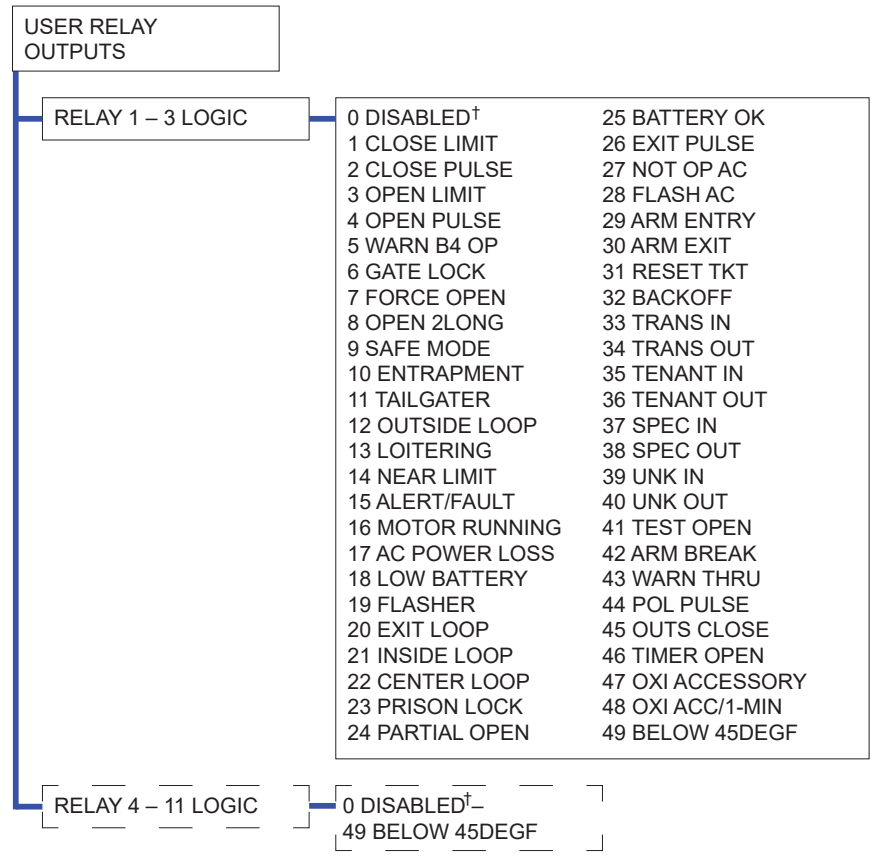

RELAY 4 – 11 ARE VISIBLE AND CONFIGURABLE ONLY WITH I/O EXPANSION MODULE WHICH CONNECTS VIA COMMUNICATION CABLE (MX4330 IN THE I/O EXPANSION MODULE KIT) FROM HS-1 ON THE SMARTTOUCH CONTROLLER TO HS-A ON THE I/O EXPANSION MODULE

Note: On SlideDriver II the I/O Expansion Module connects to HS-1 on the SmartTouch 720/725 Controller by default.

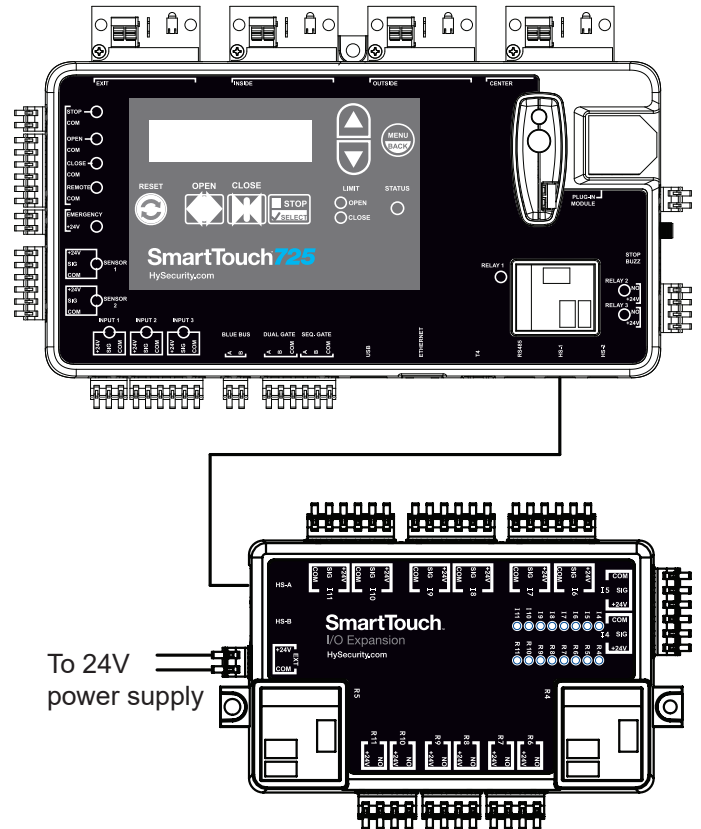

† = Indicates default

# USER RELAY OUTPUTS

**Table 13. SmartTouch 720/725 User Relay Outputs Settings**

MENU DISPLAY	SETTINGS	DESCRIPTION
RELAY 1-3 LOGIC	0 = DISABLED† 1 = CLOSE LIMIT 2 = CLOSE PULSE 3 = OPEN LIMIT 4 = OPEN PULSE 5 = WARN B4 OP 6 = GATE LOCK 7 = FORCE OPEN 8 = OPEN 2 LONG 9 = SAFE MODE 10 = ENTRAPMENT 11 = TAILGATER 12 = OUTSIDE LOOP 13 = LOITERING 14 = NEAR LIMIT 15 = ALERT/FAULT 16 = MOTOR RUNNING 17 = AC POWER LOSS 18 = LOW BATTERY 19 = FLASHER 20 = EXIT LOOP 21 = INSIDE LOOP 22 = CENTER LOOP 23 = PRISON LOCK 24 = PARTIAL OPEN 25 = BATTERY OK 26 = EXIT PULSE 27 = NOT OP AC 28 = FLASH AC 29- 40 = PARKING ARM OPERATORS ONLY 41 = TEST OPEN 42 = NOT USED 43 = WARN THRU 44 = POL PULSE 45 = OUTS CLOSE 46 = TIMER OPEN 47 = OXI ACCESSORY 48 = OXI ACC/1-MIN 49 = BELOW 45DEGF	See Table 14  Note: The relays used for the directional valve, unloader valve, and motor contactor will display their setting, but will not be configurable.
RELAY 4-11 LOGIC	SEE RELAY 1 LOGIC SETTINGS 0†	See Table 14

# USER RELAY OUTPUTS

**Table 14. User-Programmable User Relays - Function Options**

No.	Name	Description
1	Close limit output	Creates an interlock signal to another operator's interlock input, or simply to indicate that gate is secure or not. Relay is released when fully-closed limit switch is tripped. Relay is energized when fully-closed limit is released. (Any open command energizes relay.)
2	Close limit pulse output	Used in a sequenced system to command a second machine to close. Generates a brief pulsed output that occurs when close limit is triggered.
3	Open limit output	Indicates gate is at full-open position. Output becomes active when an open-limit is triggered and deactivates when open-limit is released or a close command is received. Use this output for a traffic light.
4	Open limit pulse output	Triggers a sequenced barrier arm gate operator to open. Generates a brief pulsed-output when open-limit is triggered. An additional pulse is also generated with any new open command even when gate is already fully-opened.
5	Warn before/during operate output	Controls an external warning device. This output is active whenever internal warn before operate buzzer is sounding but the relay output is constant on. Activation timing of this relay is controlled by setting Warn Before Operate.
6	Gate Lock output	Controls external solenoid locks or magnetic locks. In both directions of travel, this output is activated about 7/10ths of a second before operator starts moving the gate.
7	Gate forced open output	Activated if gate is forced off closed limit switch and operator is not able to restore gate to full closed position within four seconds. The buzzer resets itself in 30 seconds but relay stays active until gate receives a run command.
8	Gate open too long output	Activates when gate is open longer than the user-selected period of time. Adjustable from a 0 second to 15 second to 135 seconds delay in 30-second increments. <b>NOTE:</b> OPEN TIME ALERT adjustments can be made in the menus.
9	Safety Mode Alert output	Activated when system is in Safety Mode or Entrapment Mode. Safety Mode occurs upon an impact with an obstruction. Entrapment Mode means gate is stopped and occurs if inherent entrapment sensor triggers or if emergency input is activated while system is in Safety Mode.
10	Entrapment Mode Alert output	Activated only when system is in Entrapment Mode.
11	Unauthorized Vehicle Entry output	Activated when a second vehicle enters from outside without a valid input from an access control device. The OOLD and IOLD loops must be capable of being triggered at the same time for this relay to ever activate. This output releases when an access control input signals open or gate reaches the close limit position.
12	Outside Obstruction Vehicle Detector output	This output is active whenever Outside Obstruction Loop Detector is tripped. Interlocks an entry device to prevent pedestrian use.
13	Loitering Alert	Indicates vehicle is loitering on Outside Obstruction Loop with the gate closed. Adjustable from a 0 second to 15 second to 135 second delay in 30-second intervals. <b>NOTE:</b> LOITERING ALERT adjustments can be made in the menus.
14	Gate nearing full travel output	Activated when gate is approaching full open or full closed. Relay activates three feet from where firmware expects limit switch to be triggered whether moving toward full open, full close, or in a reverse travel mode.
15	Gate Failure output	Activated to report occurrence of problem. Indicates the system is in an Error, Fault, Alert, or Entrapment Mode. If active, gate is disabled.
16	Motor Running output	Active when motor is running and gate is in motion.
17	AC Power Failure output	This relay is normally energized and drops with loss of AC power.



# USER RELAY OUTPUTS

**Table 14. User-Programmable User Relays - Function Options**

No.	Name	Description
18	DC Power Failure output	Activated when battery power is very low, but output ceases when battery is dead (18 volts). Relay is triggered when battery is less than 21 volts.
19	Flasher Relay	Controls flashing lights to pulse once per second. Relay is constantly pulsing except when open limit switch is triggered. Recommended to use User Relay 2 or 3 since it is an electronic switch.
20	Free Exit Loop Vehicle Detector output	Active whenever Exit Loop is tripped.
21	Inside Obstruction Vehicle Detector output	Active whenever Inside Obstruction Vehicle Detector is tripped
22	Center Loop Detector output	Active whenever Center (Shadow) loop detector is tripped.
23	External Latching Gate Lock Output	Not functional in SmartTouch 720/725 operators.
24	Gate at Partial Open Position	Active when partial open position is reached or exceeded. (Slide gates only)
25	DC Power Alert	Active when on AC power or the battery voltage is above 21V. When used with User Relay 2, this option can shed electrical loads to conserve battery energy.
26	Free Exit Loop Detector pulse	Outputs a 250ms pulse when the free exit vehicle detector is tripped.
27	Not Open (w/ AC power)	Activated when gate is not on open limit and AC power is present. Deactivated when AC power fails or gate is on open limit.
28	Flasher (w/ AC power)	Output identical to relay #19 and pulses relay 500 ms/sec when gate not on open limit and AC power is present. Deactivated when AC power fails or gate is on open limit.
29	Arm Entry Ticket Dispenser	Not used.
30	Arm Exit Ticket Dispenser	Not used.
31	Reset Ticket Dispenser Pulse	Not used.
32	Backoff Pulse	Not used.
33	Transient In Pulse	Not used.
34	Transient Out Pulse	Not used.
35	Tenant In Pulse	Not used.
36	Tenant Out Pulse	Not used.
37	Special In Pulse	Not used.
38	Special Out Pulse	Not used.
39	Unknown In Pulse	Not used.
40	Unknown Out Pulse	Not used.
41	Test Open Pulse	Output pulses five seconds after close limit is activated. Typically used for cycle testing.
42	Break-Away Switch Output	Not used.
43	Warn Before	Combination of relays #5 and #16.
44	Partial Open Limit Pulse	Pulses for 250ms when gate, commanded with Partial Open input, reaches Partial Open Limit, or, gate is past Partial Open Limit and Partial Open input is activated.
45	Outside Obstruction/Arming Loop Detector	Activated when OOLD/OALD detector input tripped and gate closed. Used for testing purposes.

Table continued on next page

# USER RELAY OUTPUTS

---

**Table 15. User-Programmable User Relays - Function Options**

No.	Name	Description
46	Timer Open	Relay activates when 7 day timer is programmed and the timer is active.
47	OXI Accessory	Latching output controlled by an OXI remote. When pairing a remote, a button can be programmed to energize a relay and latch it until the button is pressed a second time.
48	OXI Accessory/1-min	Output controlled by an OXI remote. When pairing a remote, a button can be programmed to energize a relay and latch it for 1 minute or until the button is pressed a second time, whichever comes first.
49	Below 45deg F	Used to turn on the relay when the board temperature is below 45 °F. Normally used to turn on a heater because a board temperature of 45 °F often indicates outside temperatures are close to freezing.

# RELAY OUTPUTS - BASIC

The three relays on the SmartTouch 720/725 Controller are configurable to perform a wide range of options for integration with external devices.

- Accessory power limited to 2A at 24VDC across all inputs and relays.
  - Relay capacity: (1) Mechanical 20A max at 240VAC (Figure 37 Item 9). (2) Solid state relays 30VDC, 2A max (Figure 37 Item 10, 11).
1. Install the relay controlled device according to the manufacturer's instructions.
  2. Route the relay wires to the SmartTouch 720/725 Controller.
  3. Install the relay wires in the appropriate relay port: mechanical (Relay 1) or solid state (Relay 2 and 3) (Figure 37).

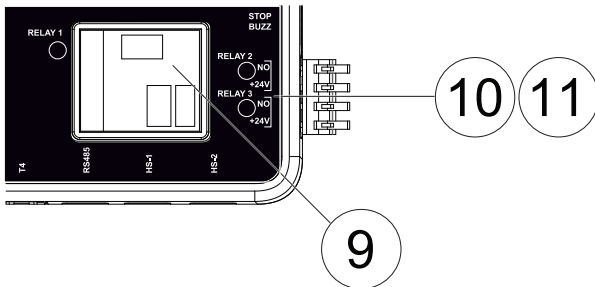
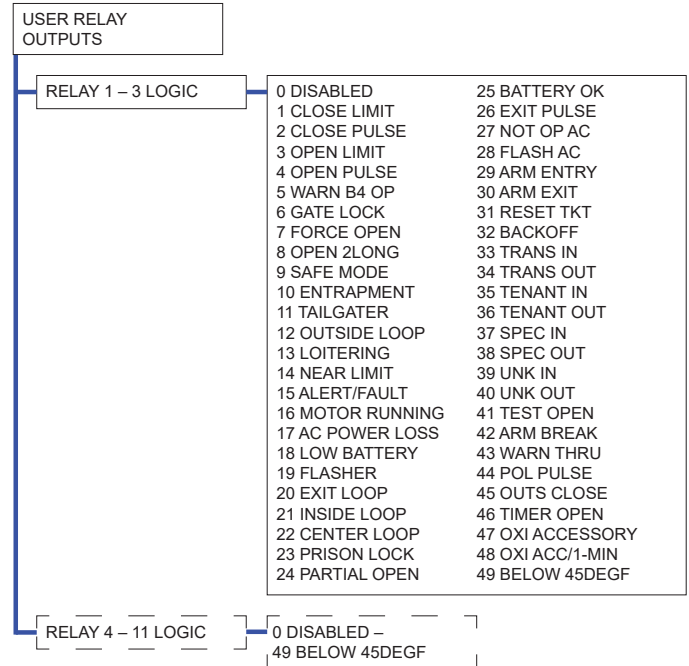

Figure 37. Relay Ports

4. Press MENU on the SmartTouch 720/725 Controller.
5. Press the UP or DOWN arrow to navigate to USER RELAY OUTPUTS, press SELECT.
6. Press the UP or DOWN arrow to navigate to RELAY LOGIC, press SELECT.
7. Press the UP or DOWN arrow to highlight the appropriate setting, press SELECT.
8. Press BACK until the SmartTouch 720/725 Controller resets and operator status displays.



RELAY 4 - 11 ARE VISIBLE AND CONFIGURABLE ONLY WITH I/O EXPANSION MODULE WHICH CONNECTS VIA COMMUNICATION CABLE (MX4330 IN THE I/O EXPANSION MODULE KIT) FROM HS-1 ON THE SMARTTOUCH CONTROLLER TO HS-A ON THE I/O EXPANSION MODULE

Note: On SlideDriver II the I/O Expansion Module connects to HS-1 on the SmartTouch 720/725 Controller by default.

# RELAY OUTPUTS - MECHANICAL

Maglocks and solenoids are common examples of relay driven devices used with gate operators to increase security. Follow these instructions to connect a maglock or solenoid to the SmartTouch 720/725 Controller:

1. Follow manufacturers instructions to install and position the relay driven device.
2. Set the power switch to OFF.
3. Connect COM on RELAY 1 to any COM terminal on the SmartTouch 720/725 Controller. HySecurity recommends Input 3 COM.
4. Connect the power lead from the maglock or solenoid to power. You can pull +24VDC from anywhere on the SmartTouch 720/725 Controller labeled +24V.
5. For a maglock, connect to the NC connector on RELAY 1. For a solenoid, connect to the NO connector.
6. Set the power switch to ON.
7. Press MENU on the SmartTouch 720/725 Controller.
8. Use the UP or DOWN button to navigate to USER RELAY OUTPUTS and press SELECT.
9. Use the UP or DOWN button to navigate to RELAY 1 LOGIC and press SELECT.
10. Use the arrow buttons to navigate to 6 GATE LOCK and press SELECT.
11. Press BACK until gate status display appears.

Note: Relay 1 can handle up to 240VAC for external power source use.

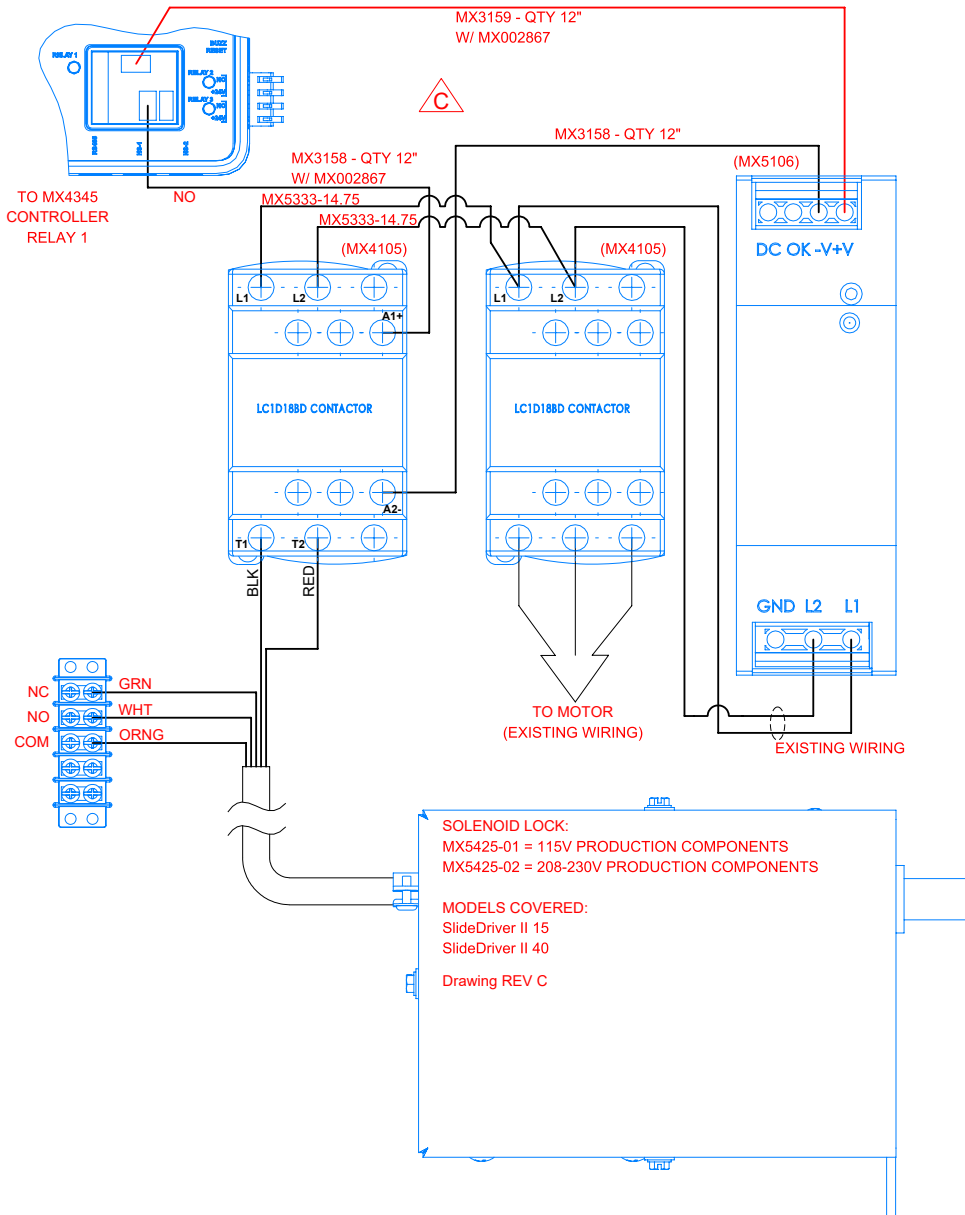

Figure 38. Solenoid Lock Wiring Example

# RELAY OUTPUTS - SOLID STATE

Solid state relay (Relay 2 and Relay 3) wiring diagrams.

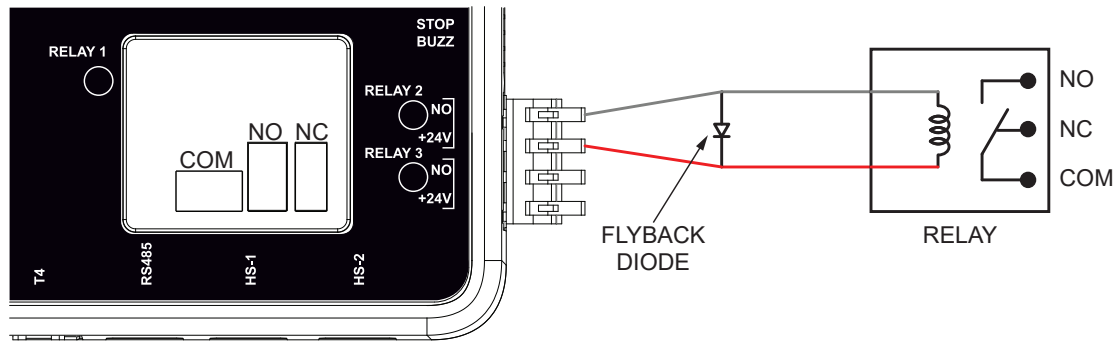

Figure 39. Wiring a 24V Accessory

Note: A flyback diode protects the SmartTouch 720/725 Controller from voltage spikes caused by switching the coil in the relay. HySecurity recommends a 1n4007 diode for use with most accessories.

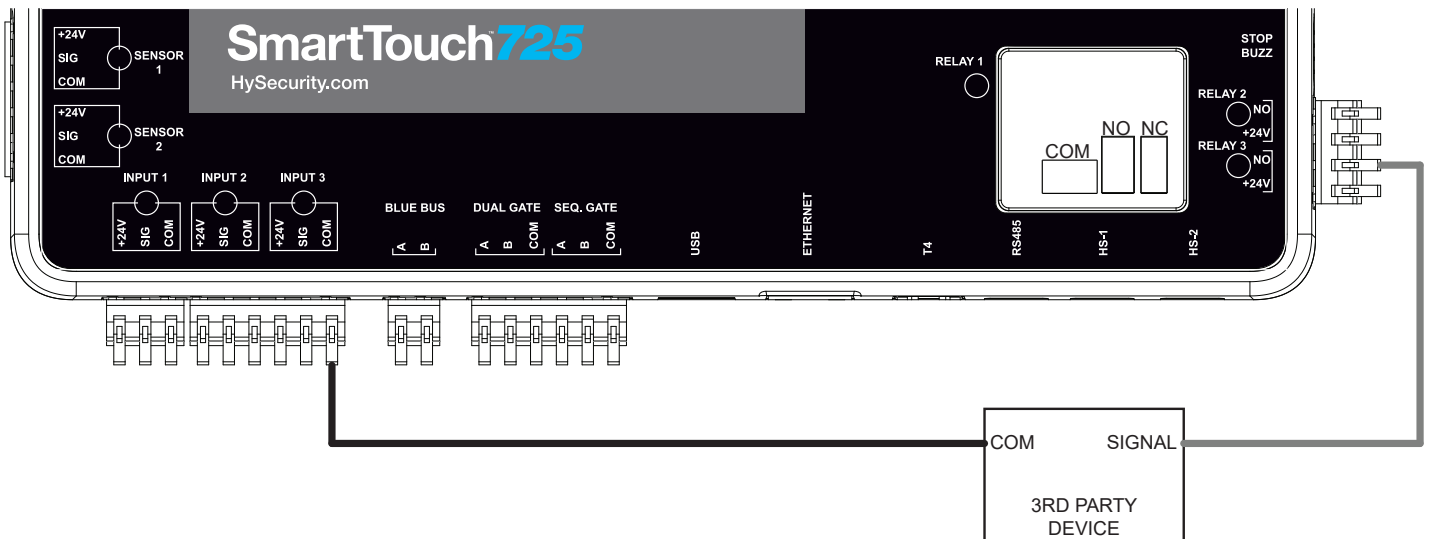

Figure 40. Wiring a 3rd Party Device

Note: Relay 2 and Relay 3 on the SmartTouch 720/725 Controller use a switched common signal when the relay is triggered.

Note: Relay 2 and Relay 3 can only handle up to 24VDC.

Note: See page 89 for additional information about available relays on the I/O Expansion Module.

# LOOP OPTIONS

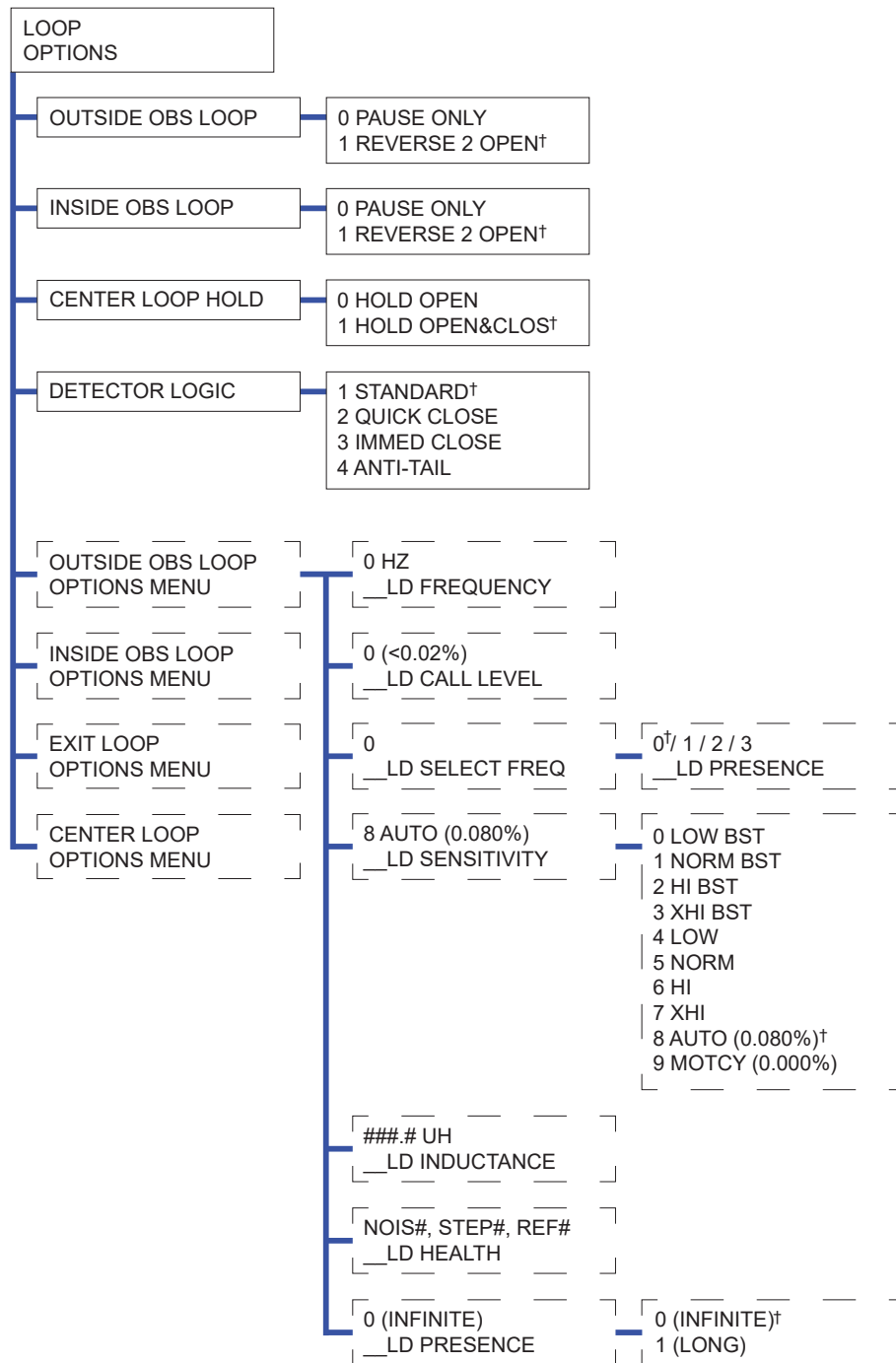

MENU STRUCTURES FOR LOOP OPTIONS ARE VISIBLE AND CONFIGURABLE ONLY WHEN AN HY5B MODULE IS INSTALLED INTO THE SMARTTOUCH CONTROLLER. OOLD, IOLD, ELD, AND CLD SUB-MENUS ARE IDENTICAL.

† = Indicates default

**Table 16. SmartTouch 720/725 Loop Options Settings**

MENU DISPLAY	SETTINGS	DESCRIPTION
OUTSIDE OBS LOOP	0 = PAUSE ONLY 1 = REVERSE 2 OPEN†	Default is for full reversal when Outside Obstruction Loop is triggered while closing. A setting of 0 causes gate to only pause when triggered. Gate closure continues as soon as loop is clear again.
INSIDE OBS LOOP	0 = PAUSE ONLY 1 = REVERSE 2 OPEN†	Default is for full reversal when Inside Obstruction Loop is triggered while closing. A setting of 0 causes gate to only pause when triggered. Closure begins as soon as loop is clear again.
CENTER LOOP HOLD	0 = HOLD OPEN 1 = HOLD OPEN&CLOS†	Swing only. When set to 1, an active center loop will prevent a full open gate from closing and a full closed gate from opening. When set to 0, an active center loop will prevent a full open gate from closing and will have no effect on a closed gate. The center loop has no effect on a gate that is in between limits or a slide gate.
DETECTOR LOGIC	1 = STANDARD† 2 = QUICK CLOSE 3 = IMMED CLOSE (SLIDE ONLY) 4 = ANTI-TAIL (SLIDE ONLY)	<p>This selection determines whether close timer begins to count down after vehicles have departed detector loops or whether close timer will count down while the loops are occupied. Gate can only close when all loop detectors are clear.</p> <p>Default settings causes Close Timer to start when all loops are clear. A setting of 2 causes Close Timer to start when open limit is reached. A setting of 3 forces the Close Timer to 0 when the OOLD and IOLD are tripped simultaneously (SLIDE ONLY). A setting of 4 stops the gate when OOLD and IOLD are tripped simultaneously and closes from that point when the loops clear (SLIDE ONLY).</p>
Note: Loop Options menu continues on next page.		

Note: On the SlideDriver II the center loop settings menu is hidden and a center loop will not affect gate movement. However, it can still be connected and programmed to trigger a relay.

# LOOP OPTIONS

**Table 17. SmartTouch 720/725 Loop Options Settings**

MENU DISPLAY	SETTINGS	DESCRIPTION
OUTSIDE OBS LOOP OPTIONS MENU		Menu structures for loop options are visible and configurable only when an HY5B module is installed into the SmartTouch 720/725 Controller. OOLD, IOLD, ELD, and CLD sub-menus are identical.
__LD FREQUENCY		Displays the center loop detector frequency
__LD CALL LEVEL		Displays the center loop detector call level
__LD SELECT FREQ	0-3	Set the center loop detector frequency 0-3
__LD SENSITIVITY	0 = LOW BST 1 = NORM BST 2 = HI BST 3 = XHI BST 4 = LOW 5 = NORM 6 = HI 7 = XHI 8 = AUTO (0.080%) <sup>†</sup> 9 = MOTCY	Set the loop detector sensitivity  Note: Automatic Gate Compensation (AGC) can be disabled while in the Hy5B loop menu. In the menu, hold the reset button for 3 seconds. The AGC menu will appear where it can be turned on or off with the arrow buttons and select button.
__LD INDUCTANCE		Displays the center loop detector inductance
__LD HEALTH		Displays the center loop detector health
__LD PRESENCE	0 = INFINITE <sup>†</sup> 1 = LONG	INFINITE = A site where standing or parked vehicular traffic (on large area loops) is a daily or consistent basis, INFINITE presence setting is a viable option. When loop may have vehicles parked on it for more than several hours and it must hold the call, set presence to INFINITE.  LONG = With sensitivity set to A (AUTO) and a large sedan stationary on loop, LONG presence may hold call for many hours before vehicle's presence is tuned out. Then, stationary vehicle is ignored and unaffected portion of loop becomes operational. In contrast, with sensitivity set to M (MOTORCYCLE), default threshold only lasts about 1 hour before presence of motorcycle on loop is tuned out.
INSIDE OBS LOOP OPTIONS MENU	SAME AS OUTSIDE LOOP OPTIONS MENU	
EXIT LOOP OPTIONS MENU	SAME AS OUTSIDE LOOP OPTIONS MENU	
CENTER LOOP OPTIONS MENU	SAME AS OUTSIDE LOOP OPTIONS MENU	



## INSTALL AN HY5B AND VEHICLE LOOP DETECTOR

There are 4 Hy5B ports on the SmartTouch 720/725 Controller: Free Exit, Outside Obstruction, Inside Obstruction, and Center. Refer to page 47 for a standard loop layout illustration.

1. Route the loop detector wires through the operator chassis to the SmartTouch 720/725 Controller.
2. Set the power switch to OFF.
3. Connect the wires to the Hy5B module.
4. Plug the Hy5B into the appropriate port (remove rubber plug).
5. Use zip ties to neatly organize the loop lead wires to keep wires out of the way and prevent them from moving.
6. Set the power switch to ON. The display will show loop detectors 'Initializing'.
7. In LOOP OPTIONS menu configure the appropriate loop detector settings.

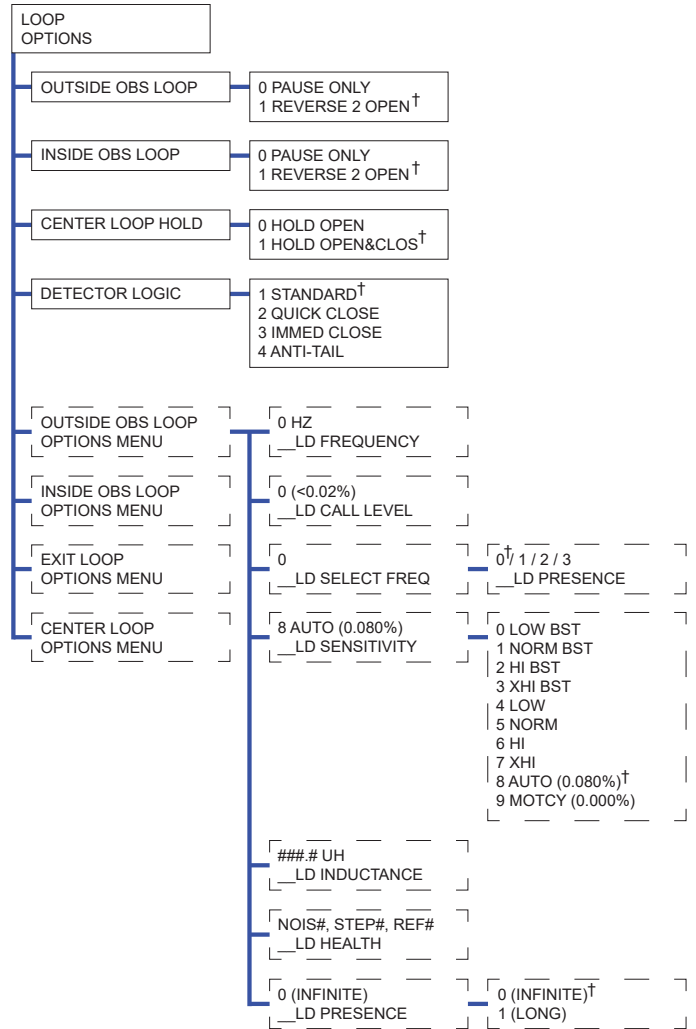
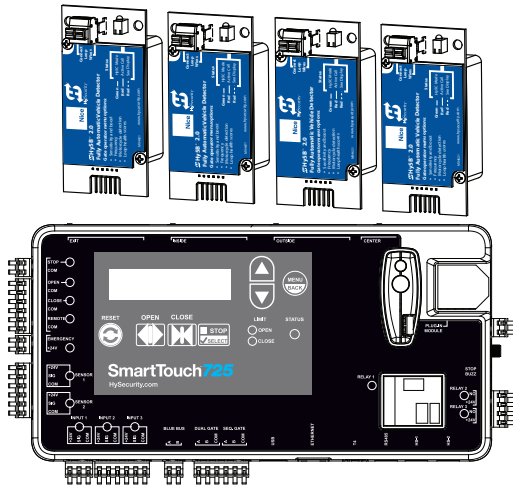

MENU STRUCTURES FOR LOOP OPTIONS ARE VISIBLE AND CONFIGURABLE ONLY WHEN AN HY5B MODULE IS INSTALLED INTO THE SMARTTOUCH CONTROLLER. OOLD, IOLD, ELD, AND CLD SUB-MENUS ARE IDENTICAL.

† = Indicates default

# SMARTTOUCH 720/725 - HY5B LOOP DIAGNOSTICS

**Table 18. Loop Noise Score**

Score	Meaning	Possible Impact on Gate Operation
7	Near perfect, no discernible noise	None
6	Very slight noise	None
5	Some noise	Not likely - Holding detects
4	Enough noise to be a concern	Not likely - False detects, holding detects
3	Noise probably impacting operation	Likely - False detects, holding detects
2	Significant noise	Likely - False detects, holding detects, will not reset
1	Very significant noise	Very likely - False detects, holding detects, will not reset
0	Severe noise	Very likely - False detects, holding detects, will not reset
-	A valid noise score was not detected	Very likely - False detects, holding detects, will not reset

**Table 19. Loop Step Changes Score**

Score	Meaning	Possible Impact on Gate Operation
7	No step changes recorded	None
6	One step change recorded	Possible - False detects, locked in call
5	2 to 3 step changes recorded	Likely - False detects, locked in call
4	4 to 5 step changes recorded	Likely - False detects, locked in call
3	More than a few step changes recorded	Very likely - False detects, locked in call
2	Significant number of step changes recorded	Very likely - False detects, locked in call
1	Very significant number of step changes recorded	Very likely - False detects, locked in call
0	Severe number of step changes recorded	Very likely - False detects, locked in call

**Table 20. Loop References Changes Score**

Score	Meaning	Possible Impact on Gate Operation
7	Very stable reference	None
6	Stable reference	None
5	Edge of normal temperature swing	None
4	Wide temperature swing	Not likely - False detects
3	Edge of effects due to any temperature swing	Not likely - False detects
2	Significant reference movement	Possible false detects
1	Very significant reference movement	Possible false detects
0	Severe reference movement	Possible false detects

# SMARTTOUCH 720/725 - HY5B LOOP DIAGNOSTICS

---

## Possible Causes of Loop Noise:

- Inductively-Coupled Loop Cross-talk – This is interference between two or more active loops. If all detectors used are Hy5Bs, this is not the source of the noise as the operator turns on and off each detector in sequence to ensure that this type of cross-talk cannot occur. If you are experiencing this issue, installing all Hy5Bs will be the most effective mitigation technique. If this is not possible, changing the frequency of one or both of the loops that are interfering usually reduces the cross-talk to acceptable levels.
- Capacitively-Coupled Interference – This is interference between electrical wiring in close proximity to each other (usually in the same conduit) for significant distances (usually 50 feet or more). The longer the distance the more pronounced the effect. Twisting of the loop lead in wires will help with this. If a shielded cable is used for the loop wires, the shield of the cable should be left floating (unconnected) at both ends.
- Other Electrical Interference – This is usually interference that is coupled in to the loop, lead-in, or detector itself. Changing the loop frequency on the detector may help. If the interference is coupling in to the loop itself, a figure 8 loop may be needed to mitigate the source of interference. If the interference is at the detector, additional shielding may be needed.

## Possible Causes of Loop Step Changes:

- Loose Electrical Connections – If there are any splices in the loop wires, they should be checked. Wire nuts should never be used in loop connections and usually will create these types of issues. If there are splices, they should be soldered if possible or at the very least crimped.
- Failed Loop Wire Insulation – This normally occurs when there is a high moisture content in the air that condenses (rain, fog, or dew) and the loop wire insulation is damaged in some way and this moisture can wick its way to that failure point. Using a megaohm meter on the loop and getting a reading of less than 100 megaohms will usually indicate this type of issue.
- Conductor Fatigue – If the loop is installed across a joint in the driving surface or the lead-in is exposed to significant vibration, the conductor in the wire may fatigue and change its resistance slightly when flexed. With this type of failure, the failed wire must be replaced.
- Objects Embedded in the Saw Slot – It is possible for objects (nails, screws, etc.) to become embedded in the saw slot sealant and over time get pressed down in to the loop wire (especially if good installation practices are not followed). Once this object touches a loop wire conductor, the loop must be replaced.

## Possible causes of loop reference changes:

- Wide Temperature Swings – The reference within the detector will change with temperature. If there are wide temperature swings during a 24-hour period, this score will go down and is expected and normal. The detector is designed to deal with ambient temperature changes of 2°F every minute. Rates of change faster than that may cause false detections (this usually only occurs if the cabinet is opened). If you are in an area that sees quick temperature changes (hot or cold), some insulation around the detectors may help.
- Temperature Sensitivity – It is possible that some of the components on the detector are abnormally temperature sensitive.

Note: Refer to Hy5B User and Reference Guide (MX4125) for full information about Hy5B vehicle detectors.

# EXTERNAL COMMUNICATIONS

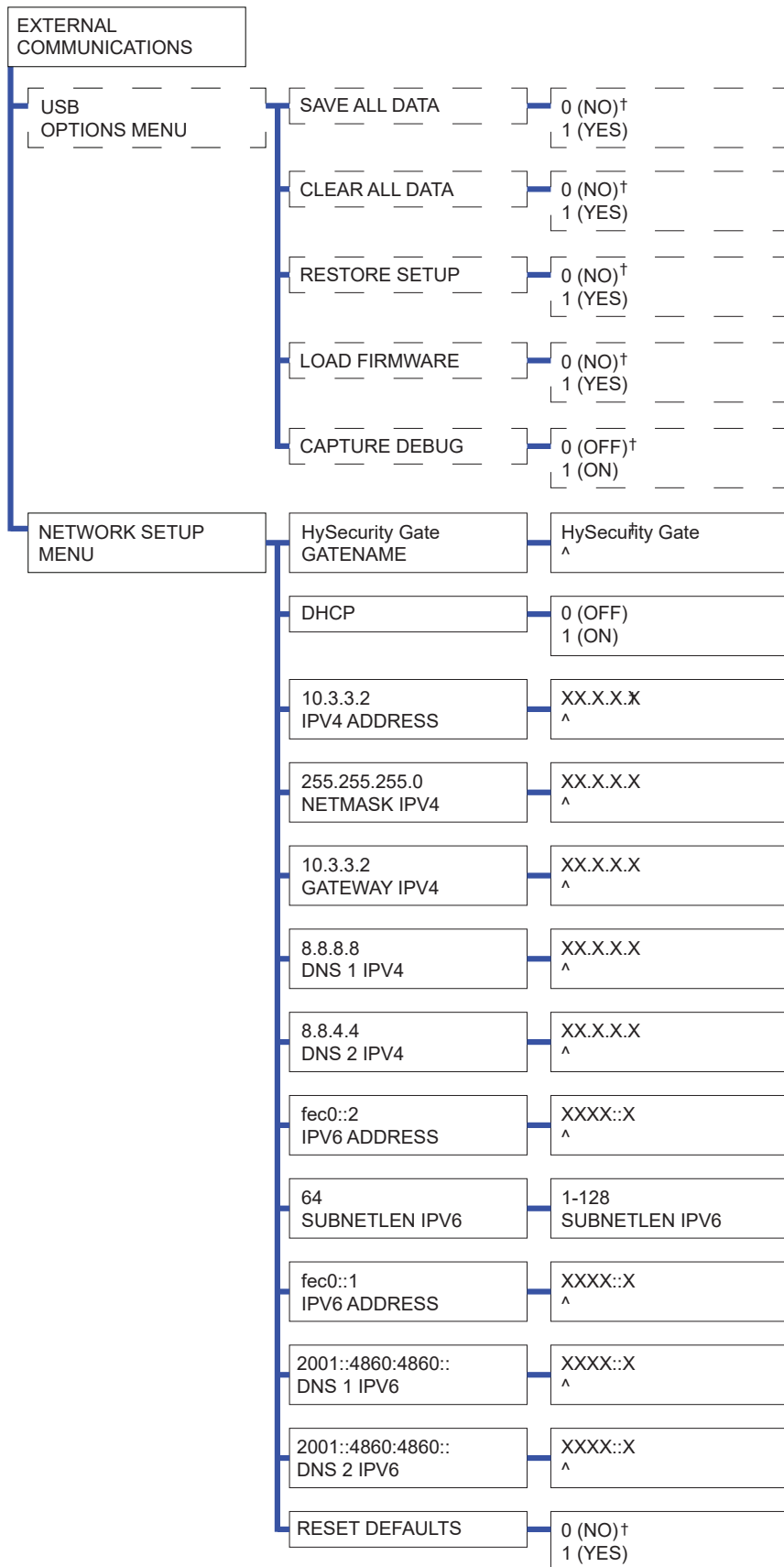

† = Indicates default

# EXTERNAL COMMUNICATIONS

**Table 21. SmartTouch 725 External Communications Settings**

MENU DISPLAY	SETTINGS	DESCRIPTION
USB OPTIONS MENU		USB options submenu, only appears when a USB flash drive is connected to the SmartTouch 720/725 Controller.
SAVE ALL DATA	0 = NO <sup>†</sup> 1 = YES	Saves the event log data, any stored debug data events, and the menu setup file.
CLEAR ALL DATA	0 = NO <sup>†</sup> 1 = YES	Clears the event log and any stored debug data.
RESTORE SETUP	0 = OFF <sup>†</sup> 1 = ON	Loads a saved menu setup file onto a new SmartTouch 720/725 controller or operator.
LOAD FIRMWARE	0 = OFF <sup>†</sup> 1 = ON	Set to ON after plugging in a USB flash drive with firmware updates to load new firmware.
CAPTURE DEBUG	0 = OFF 1 = ON	Saves real time debug data onto a USB flash drive until the setting is changed to 1 (ON) or the stop button is pressed. The debug data can be used to determine if there are any intermittent input activations.
NETWORK SETUP MENU*		Network setup submenu
HYSECURITY GATE GATE NAME	HySecurity Gate ^	Set the name of the operator. Default name includes a four digit number for easy identification when pairing with bluetooth.
DHCP	0 = OFF <sup>†</sup> 1 = ON	Used to assign dynamic IP addresses to devices on a network.
IPV4 ADDRESS	XX.X.X.X ^	IP address on IPv4
NETMASK IPV4	XXX.XXX.XXX.X ^	Subnet mask on IPv4
GATEWAY IPV4	XX.X.X.X ^	Gateway on IPv4
DNS 1 IPV4	X.X.X.X ^	Domain Name System address 1 on IPv4
DNS 2 IPV4	X.X.X.X ^	Domain Name System address 2 on IPv4
IPV6 ADDRESS	XXXX::X ^	IP address on IPv6
SUBNETLEN IPV6	1-128 (64 <sup>†</sup> )	IPV6 prefix length
GATEWAY IPV6	XXXX::X ^	Gateway on IPv6
DNS 1 IPV6	XXXX::XXXX::XXXX:: ^	Domain Name System address 1 on IPv6
DNS 2 IPV6	XXXX::XXXX::XXXX:: ^	Domain Name System address 2 on IPv6
MAC ADDRESS	XXXXXXXX-XXXXXX	Manufacturer set Media Access Control address
RESET DEFAULTS	0 = NO <sup>†</sup> 1 = YES	Reset network settings.

Note: External Communications menu continues on page 82

\*The NETWORK SETUP MENU settings are for the built-in HyNet functionality. Contact an IT professional for assistance with these settings to connect to a network. The SmartTouch 725 Controller can also connect to a network through the RS485 port and a separate HyNet module.

# EXTERNAL COMMUNICATIONS

Continued from page 81

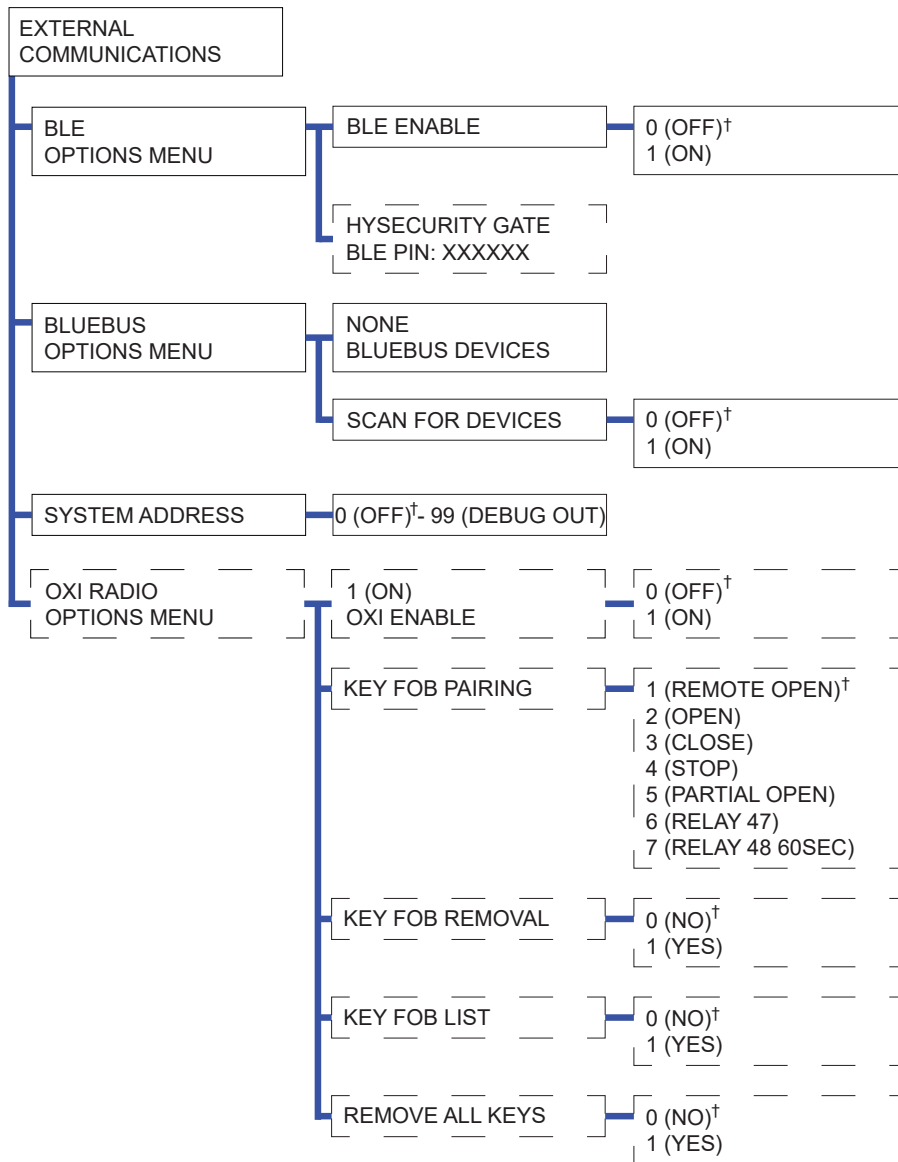

† = Indicates default

# EXTERNAL COMMUNICATIONS

**Table 22. SmartTouch 725 External Communications Settings**

MENU DISPLAY	SETTINGS	DESCRIPTION
BLE OPTIONS MENU		Bluetooth low energy submenu
BLE ENABLE	0 = OFF <sup>†</sup> 1 = ON	Enable or disable bluetooth low energy. Bluetooth logo will appear on gate status display.
HYSECURITY GATE PIN	XXXXXX	PIN to connect to the SmartTouch 725 Controller with the SMART installer app. HySecurity Gate PIN only appears when BLE Enable is set to 1 (ON).
BLUEBUS OPTIONS MENU		BlueBUS submenu
NONE, BLUEBUS DEVICES		Lists the configurations of the connected BlueBUS devices.
SCAN FOR DEVICES	0 = OFF <sup>†</sup> 1 = ON	Change to 1 (ON) to scan for BlueBUS devices. Use this function to install and uninstall BlueBUS device for the firmware to recognize and monitor as an external entrapment sensor(s).
SYSTEM ADDRESS	0 (OFF) <sup>†</sup> - 99 (DEBUG OUT)	Set system address for network communication: 0 = no network communication 1 - 99 sets individual polling addresses.
OXI MENU		OXI Submenu, only appears when a receiver is connected to the SmartTouch 725 Controller.
OXI ENABLE	0 = OFF <sup>†</sup> 1 = ON	Enables or disables the NICE OXI/A receiver. The rest of the menus only appear when OXI Enable is set to 1 (ON).
KEY FOB PAIRING	1 = REMOTE OPEN <sup>†</sup> 2 = OPEN 3 = CLOSE 4 = STOP 5 = PARTIAL OPEN 6 = RELAY 47 7 = RELAY 48 60SEC	Set the function to assign to a fob/button and then press the fob button to pair it to the SmartTouch 725 Controller.
KEY FOB REMOVAL	0 = NO <sup>†</sup> 1 = YES	Set to YES and activate a fob button to remove it from the SmartTouch 725 Controller.
KEY FOB LIST	0 = NO <sup>†</sup> 1 = YES	Set to YES to use the arrow buttons to scroll through the list of paired fobs. While scrolling through the programmed fobs, pressing SELECT on the displayed key fob button will give the option to delete the individual fob.
REMOVE ALL KEYS	1 = NO <sup>†</sup> 1 = YES	Set to YES to remove all paired fobs from the SmartTouch 725 Controller.

# CONNECT TO THE SMART INSTALLER APP

Note: The SmartTouch 725 Controller initial setup must be completed before you can connect to the Smart Installer App.

## Set Bluetooth jumper/switch:

1. Set the power switch to OFF.
2. Remove the rubber plug or OXI receiver from OXI receiver slot (Figure 41).
3. Move the jumper or switch to the ON position. (Left two pins on three pin version or to the left on slide switch, Figure 42)
4. Place the rubber plug in the OXI receiver slot.

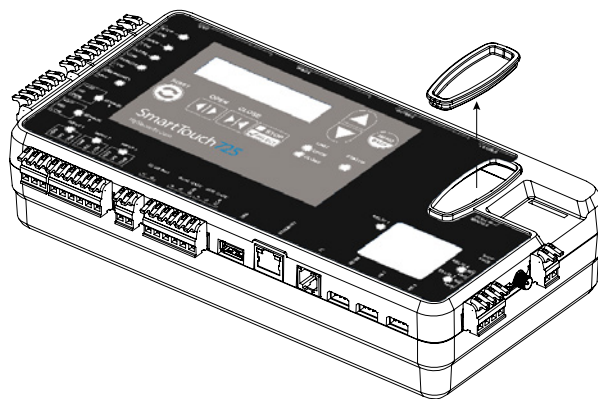

Figure 41. Remove OXI Receiver Cover

## Enable Bluetooth in the menus:

5. Set the power switch to ON.
6. Press MENU on the SmartTouch 725 Controller.
7. Press the UP or DOWN arrow to navigate to EXTERNAL COMMUNICATIONS and press SELECT.
8. Press the UP or DOWN arrow to navigate to BLE OPTIONS MENU and press SELECT.
9. Press the UP or DOWN arrow to select 1 (ON) and press SELECT.
10. Press the UP or DOWN arrow to show HYSECURITY GATE PIN and GATE NAME. Record the PIN and GATE NAME.

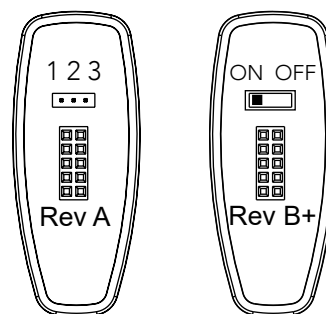

Figure 42. Bluetooth Switch



Figure 43. Bluetooth Enabled Display

Note: Bluetooth range with the SlideDriver II cover on is ~10 ft (3 m). Bluetooth range can be increased by removing the cover.

## Connect the app and controller:

11. Open the SmartTouch Installer App. Always keep the app up-to-date.
12. Tap Connect.
13. Tap the name of the appropriate operator.
14. Enter the PIN from step 10.
15. Connect button changes color to green to indicate good connection.



Figure 44. Smart Installer App Connect and Disconnect



# OXI INSTALLATION AND PROGRAMMING

Note: The button on the OXI receiver is not needed for programming fobs for the SmartTouch 725 Controller and should not be pressed during the following installation processes.

## Install and enable the OXI receiver:

1. Remove the OXI port rubber plug.
2. Install the OXI receiver.
3. Install a coaxial antenna into the OXI receiver terminals for better range (Figure 45). Route the cable through a knock out in the electrical enclosure and conduit to a fixed fence post near the operator. Mount the external antenna on top of the fixed fence post.
4. Press MENU on the SmartTouch 725 Controller.
5. Press the UP or DOWN arrow to navigate to EXTERNAL COMMUNICATIONS and press SELECT.
6. Press the UP or DOWN arrow to navigate to OXI RADIO MENU OPTIONS and press SELECT.
7. Press the UP or DOWN arrow to navigate to OXI ENABLE and press SELECT.
8. Press the UP or DOWN arrow to select ON and press SELECT.

## Pair a fob:

1. Open OXI RADIO MENU OPTIONS (steps 4 - 6 to install OXI).
2. Press the UP or DOWN arrow to navigate to KEY FOB PAIRING and press SELECT.
3. Press the UP or DOWN arrow to select the function.
4. Press and hold the appropriate button on the fob.
5. Press SELECT. Display will beep and state PAIRED.
6. Repeat steps 2 - 5 to pair additional fob buttons or fobs.
7. Press MENU until gate status displays.
8. Press the buttons on the fob to test operation.

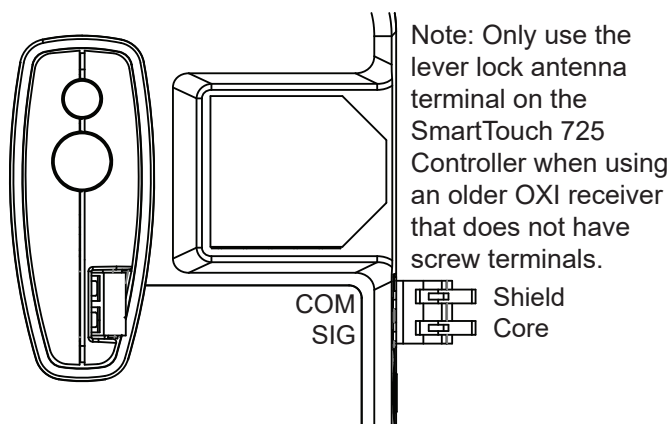

Figure 45. OXI Antenna Terminal

## Remove a single fob in hand:

1. Open OXI RADIO MENU OPTIONS (steps 4 - 6 to install OXI).
2. Press the UP or DOWN arrow to navigate to KEY FOB REMOVAL and press SELECT.
3. Press the UP or DOWN arrow to select 1 (ON).
4. Press and hold the button on the fob and press SELECT to remove.
5. Repeat steps 3 and 4 for every fob button to be removed.

## Remove a single fob from a list:

Note: It is important to keep a log of fobs and who is responsible for each for this method.

1. Open OXI RADIO MENU OPTIONS (steps 4 - 6 to install OXI).
2. Press the UP or DOWN arrow to navigate to KEY FOB LIST and press SELECT.
3. Press the UP or DOWN arrow to navigate to the fob number in the list and press SELECT.
4. Press the UP or DOWN arrow to select Y and press SELECT. This removes the fob.

## Remove all fobs:

1. Open OXI RADIO MENU OPTIONS (steps 4 - 6 to install OXI).
2. Press the UP or DOWN arrow to navigate to REMOVE ALL KEYS and press SELECT.
3. Change the setting to 1 (YES) and press SELECT.

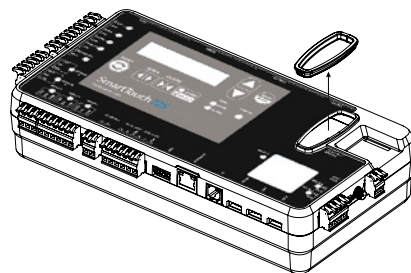

Figure 46. Remove OXI Port Rubber Plug

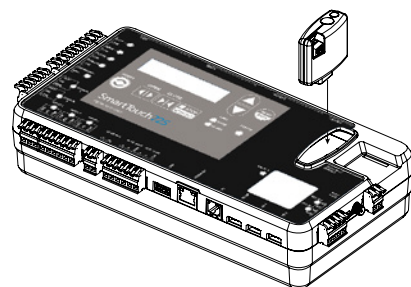

Figure 47. Install OXI Receiver

# FIRMWARE UPDATES AND DEBUG DATA

## Download the firmware to a USB flash drive:

1. Go to [support.hysecurity.com](http://support.hysecurity.com), click on Software, click SmartCNX Code h6.##, and click h.6.##.cnx to download the .cnx firmware file.
2. Connect a USB flash drive to your computer.

Note: FAT32 is the preferred file system for USB flash drives used for SmartTouch 720/725 firmware updates.

3. Navigate to the download folder with the .cnx file.
4. Copy the .cnx file to the root folder of the USB flash drive.
5. Safely disconnect the USB flash drive.

## Install the firmware:

1. Move the gate to the open position to allow free flow of traffic. The SmartTouch 720/725 Controller ignores all inputs and outputs during the firmware update.
2. Plug the USB flash drive into the USB port on the SmartTouch 720/725 Controller (Figure 48).
3. Press SELECT when USB OPTIONS MENU appears.
4. Press the UP or DOWN arrow to LOAD SW and press SELECT.
5. Press the UP or DOWN arrow to YES and press SELECT.
6. The display shows LOADING FW while the firmware loads. It could take up to 10 minutes to load the firmware.

### NOTICE

Do not shut off power. Do not remove the USB flash drive or disconnect any other cable during firmware update. This can cause SmartTouch 720/725 Controller communication to stop and requires a SmartTouch 720/725 Controller replacement.

7. The display shows COMPLETE and the controller beeps once when firmware loading ends.
8. Remove the USB flash drive.

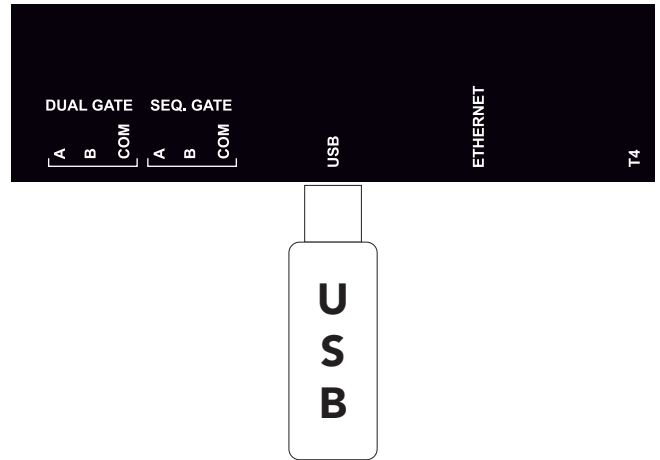
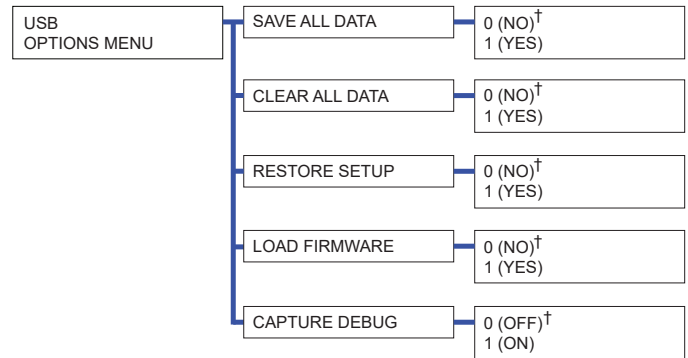

Figure 48. USB Port



SAVE ALL DATA saves the event log data, any stored debug data events, and the menu setup file.

CLEAR ALL DATA clears the event log and any stored debug data.

RESTORE SETUP loads a saved menu setup file onto a new SmartTouch 720/725 Controller or operator.

LOAD FIRMWARE loads new firmware after plugging in a USB flash drive with firmware for updates.

CAPTURE DEBUG saves real time debug data onto a USB flash drive until the setting is changed to 0 (OFF). The debug data can be used to determine if there are any intermittent input activations.

† = Indicates default

Page intentionally left blank.

# I/O EXPANSION MODULE INPUTS

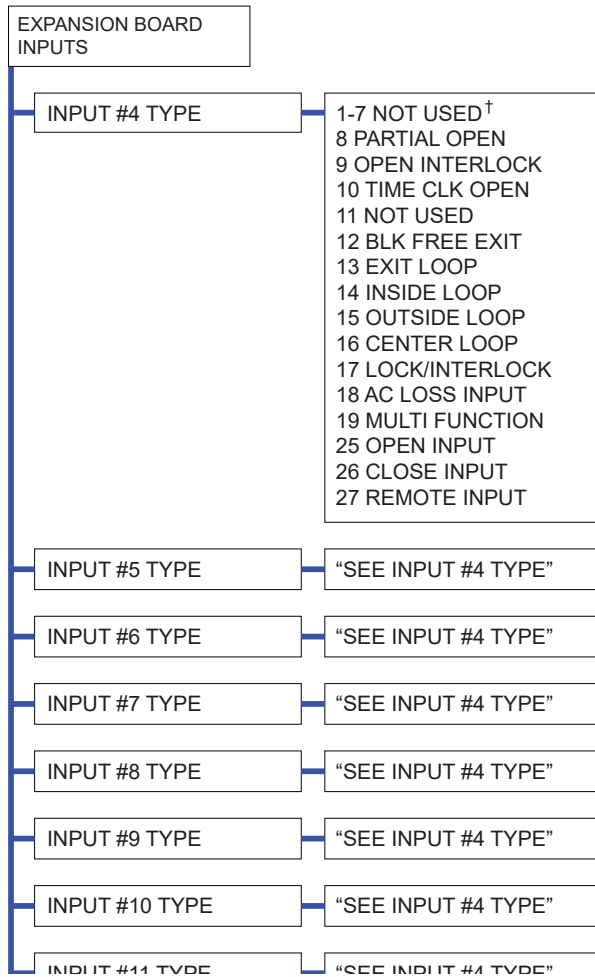

**Table 23. SmartTouch 720/725 I/O Expansion Module Inputs Settings**

MENU DISPLAY	SETTINGS	DESCRIPTION
INPUT #4-#11 TYPE	1 = NOT USED <sup>†</sup> 2-7= NOT USED 8 = PARTIAL OPEN (SLIDE ONLY) 9 = OPEN INTERLOCK 10 = TIME CLK OPEN 11 = NOT USED 12 = BLK FREE EXIT 13 = EXIT LOOP 14 = INSIDE LOOP 15 = OUTSIDE LOOP 16 = CENTER LOOP 17 = LOCK/INTERLOCK 18 = AC LOSS INPUT 19 = WAKE DISPLAY 25 = OPEN INPUT 26 = CLOSE INPUT 27 = REMOTE INPUT	Some inputs are preset and named based on their use in the SlideDriver II operator. These inputs are read only in the menu. Fixed inputs include limits, pressure transducer, and motor thermal switch or AC loss indicator.

Note: For I/O Expansion Module relays see Relay Outputs on page 66.

<sup>†</sup> = Indicates default

I/O Expansion Module Mounting Holes on Front and Bottom of Electrical Box

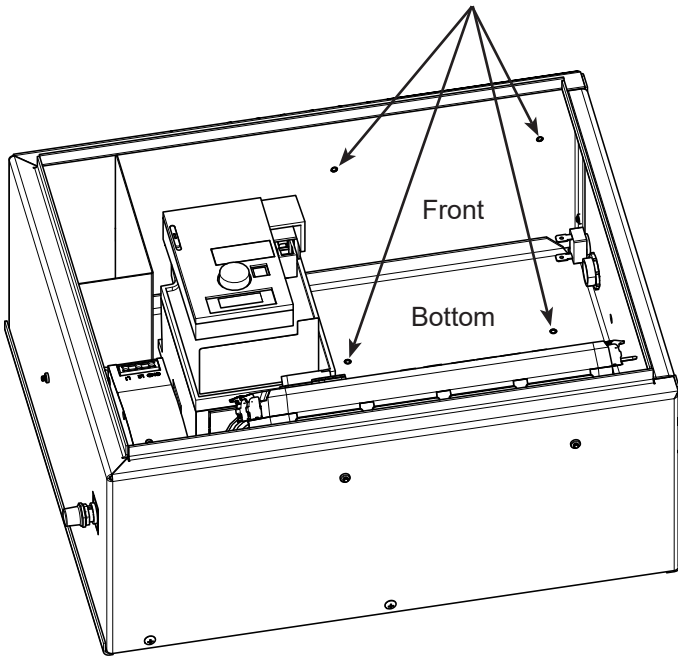

Figure 49. SmartTouch 720/725 I/O Expansion Module Mounting Holes

All SlideDriver II operators not equipped with a VFD come with an I/O Expansion Module with the following defaults (visible, not configurable):

Table 24. I/O Expansion Module Default Settings	
Input/Relay	Setting
Input 8	Motor thermal switch/AC power loss
Input 9	Pressure transducer
Input 10	Limit 1
Input 11	Limit 2
Relay 4	Motor Contactor
Relay 10	Unloader Valve
Relay 11	Directional Valve

The other Inputs and Relays are visible and user configurable.

For operators equipped with a VFD, the I/O Expansion Module is an optional accessory and all Inputs and Relays are visible and configurable.

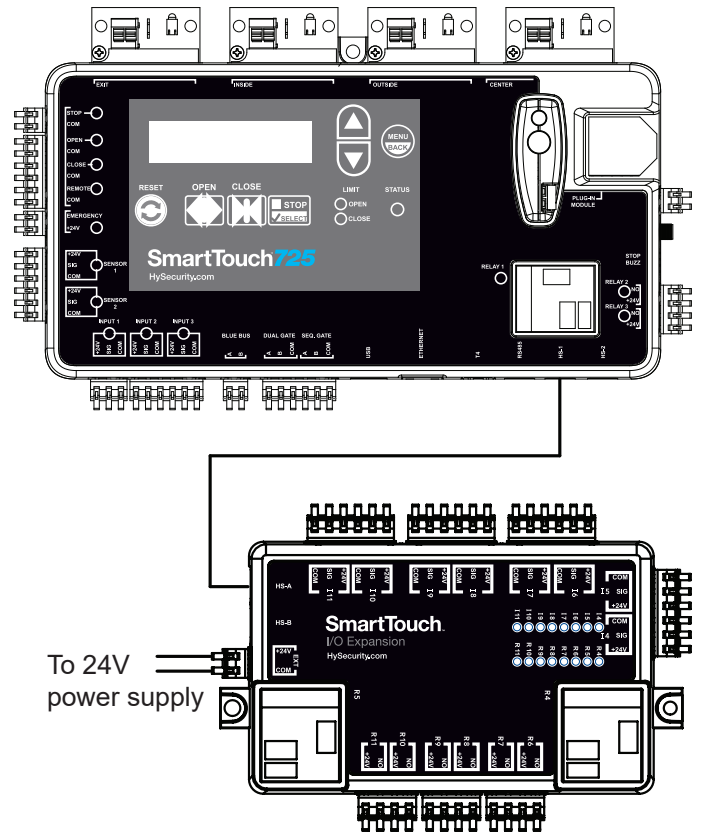
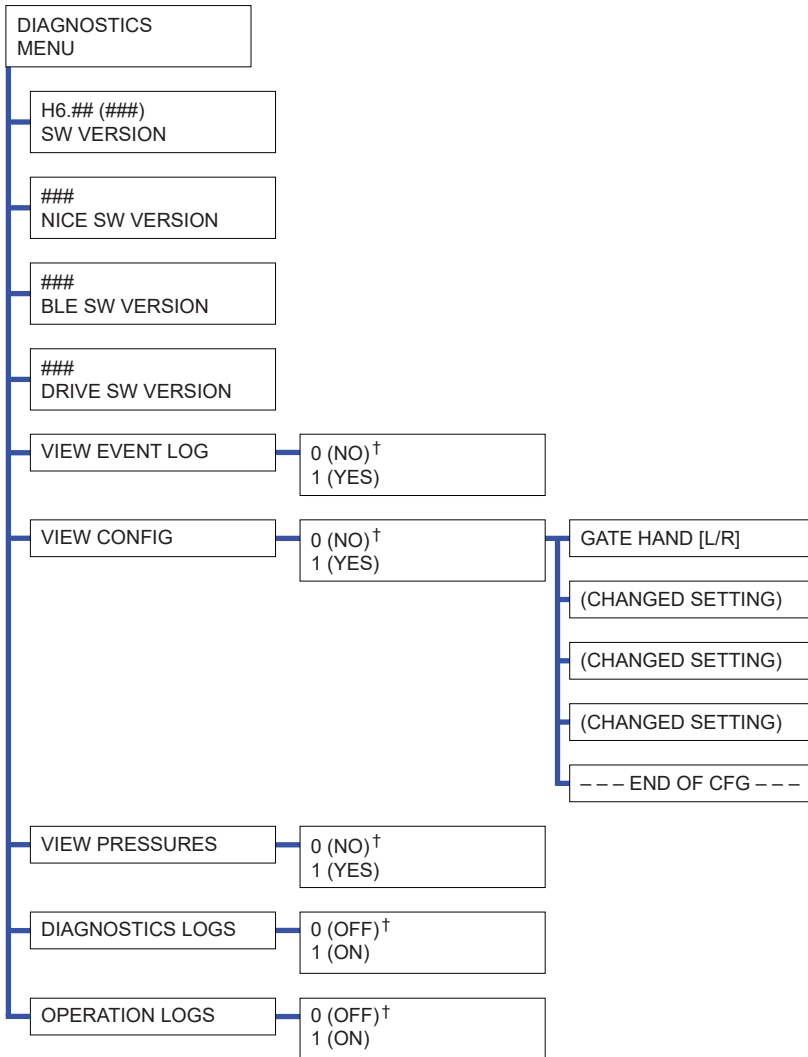

Figure 50. SmartTouch 720/725 I/O Expansion Module Connections

# DIAGNOSTICS MENU

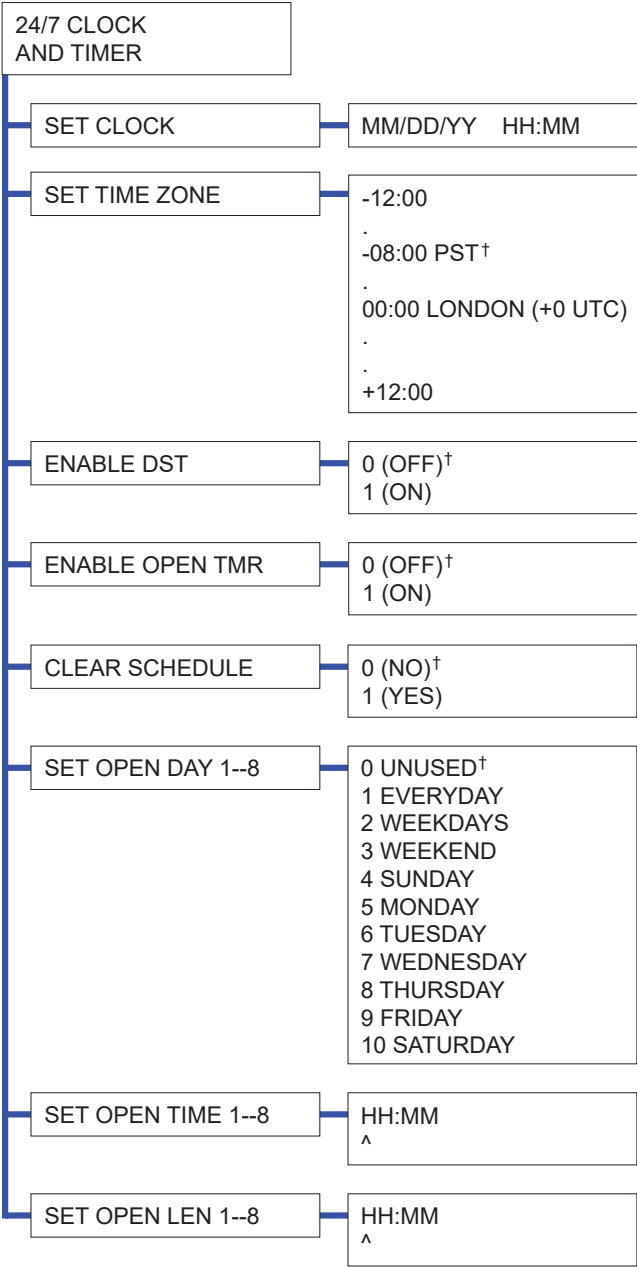

**Table 25. SmartTouch 720/725 Diagnostics Menu Settings**

MENU DISPLAY	SETTINGS	DESCRIPTION
VIEW EVENT LOG	0 = NO <sup>†</sup> 1 = YES	View a list of events in the SmartTouch 720/725 Controller's memory.
VIEW CONFIG	0 = NO <sup>†</sup> 1 = YES	View a list of configuration settings for the operator that are different from the defaults (e.g. gate handing and input settings).
VIEW PRESSURES	0 = NO <sup>†</sup> 1 = YES	View the last three cycles of system pressure.
DIAGNOSTICS LOGS	0 = OFF <sup>†</sup> 1 = ON	Set to ON to turn on diagnostic logging which logs every aspect of gate operation. Diagnostic logging bogs down the processor and slows response to operate command. Only use when absolutely needed to capture an intermittent issue.
OPERATION LOGS	0 = OFF <sup>†</sup> 1 = ON	

Open the Diagnostics Menu to cycle through a status display of the firmware versions of the different processors (SmartTouch 720/725 Controller, Nice, BLE, Drive module, I/O Expansion Module).

† = Indicates default



† = Indicates default

# CLOCK AND TIMER

**Table 26. SmartTouch 24/7 Clock and Timer Settings**

MENU DISPLAY	SETTINGS	DESCRIPTION
SET CLOCK	MM/DD/YY HH:MM ^	Set the date and time. Date and time must be set before open timers can be used.
ENABLE OPEN TIMER	0 = OFF <sup>†</sup> 1 = ON	Enable or disable the open timer. When enabled, any open timer that is programmed will hold the gate open at the programmed time for the programmed duration. Additionally, any relay set to option 46 will be activated regardless of the enable open timer setting.
ENABLE DST	0 = OFF <sup>†</sup> 1 = ON	Enable DST (Daylight Savings Time)
SET TIME ZONE	-12:00 . -08:00 PST <sup>†</sup> . 00:00 . . +12:00	Set time zone based on standard UTC/GMT. Do not set based on DST.
CLEAR SCHEDULE	0 = NO <sup>†</sup> 1 = YES	Clear all programmed open timer settings.
SET OPEN DAY 1-8	0 = UNUSED <sup>†</sup> 1 = EVERYDAY 2 = WEEKDAYS 3 = WEEKEND 4 = SUNDAY 5 = MONDAY 6 = TUESDAY 7 = WEDNESDAY 8 = THURSDAY 9 = FRIDAY 10 = SATURDAY	Assign day setting to open timer setting 1-8.
SET OPEN TIME 1-8	HH:MM ^	Set the time when the programmed open timer (1-8) turns on the programmed relay or opens the gate.
SET OPEN LENGTH 1-8	HH:MM ^	Set the duration of time that the programmed open timer (1-8) holds the gate open.



## MECHANICAL MAINTENANCE

### CAUTION

Before checking internal mechanisms of operator, turn off all power switches.

SlideDriver II mechanical maintenance should be performed on a routine basis. The standard operator chassis has zinc based corrosion protection, but some environments may speed corrosion.

Schedule regular maintenance and look for the following:

- Verify center clamp has proper compression (see page 23). Check for drive wheel wear and damage. Fraying edges or galling indicate that the wheels are due for replacement.
- Check for signs of rust. If any areas of rust are found, reduce spread of corrosion by treating areas with a rust inhibitor.

## SLIDEDRIVER OPERATOR MAINTENANCE SCHEDULE

Name of part	What to do	Check at these recommended monthly intervals				
		1	3	6	12	24
Gate and hardware	Check for damage and wear *1	X				
Drive rail	Check for proper alignment *2		X			
Wheel clamp spring	Check for clamping tension *3		X			
Drive wheels	Check for tightness and wear *4		X			
Dual limit sensor	Check for proper alignment *5		X			
Limit flags	Check for proper alignment *5			X		
Anchor bolts	Check for tightness			X		
Fluid level	Check for loss of fluid *6				X	
Hydraulic fluid	Drain and replace fluid *6					X
Motor Brushes (DC Only)	Replace *7					X

1. Your gate and gate hardware will require more maintenance than your HySecurity operator. A damaged gate or worn hardware may cause slow or erratic operation and will result in excess drive wheel wear. Lubricate gate hardware more frequently and check for smooth operation by opening the toggle clamping mechanism and then pushing the gate manually. One person should easily be able to push all but the largest of gates. Damaged or warped gate panels should be straightened or replaced.
2. See "Drive Rail" on page 94.
3. See "Drive Wheel Spring Tension (Adjustment of Manual Release)" on page 95.
4. Normally, drive wheel life is many years. They are designed to avoid slipping on the rail. Drive wheel life may be greatly shortened by any of these faults: clamping spring not adjusted correctly, operator or drive rail misaligned in relation to gate panel, badly warped gate panel, extremely stiff gate hardware, brake valves set to stop too fast, and/or loose wheel mounting bolts (tighten to 18 ft-lb).
5. The dual limit sensor should be spaced  $\frac{1}{4}$  to  $\frac{3}{4}$  in (6 to 19 mm) away from the limit flags and vertically centered over the limit flags. Maladjustment may result in false or early tripping or no limit function at the end of travel. Verify that the limit flags are tightly bolted to the drive rail. Verify the limit sensors are snug in their mounts.
6. See "Hydraulic System Maintenance" on page 97.
7. DC Operators use DC motors with 4 carbon brushes which wear in normal operation. Worn brushes can damage the DC motor. Under severe conditions HySecurity recommends that brushes be checked after 2 years or 250,000 cycles and the replacement interval be adjusted as necessary.

# MAINTENANCE

## Drive Rail

Verify that the drive rail does not move down, more than 1 in up, or ¼ in side-to-side throughout the entire horizontal travel of the gate.

### NOTICE

The drive rail must not move down or it will rub against the dual limit sensor(s). Adjust the drive rail so it does not rub on the dual limit sensor(s).

To adjust the rail for side-to-side movements, loosen the U-bolts and insert or remove shims between the rail and the gate where necessary.

To adjust up or down, loosen the U-bolts and tap the rail with a hammer until the correct height is reached.

If using XtremeDrive wheels, the height of the drive rail needs to be set between 9½ in to 10 in (235 to 255 mm) from base of SlideDriver chassis.

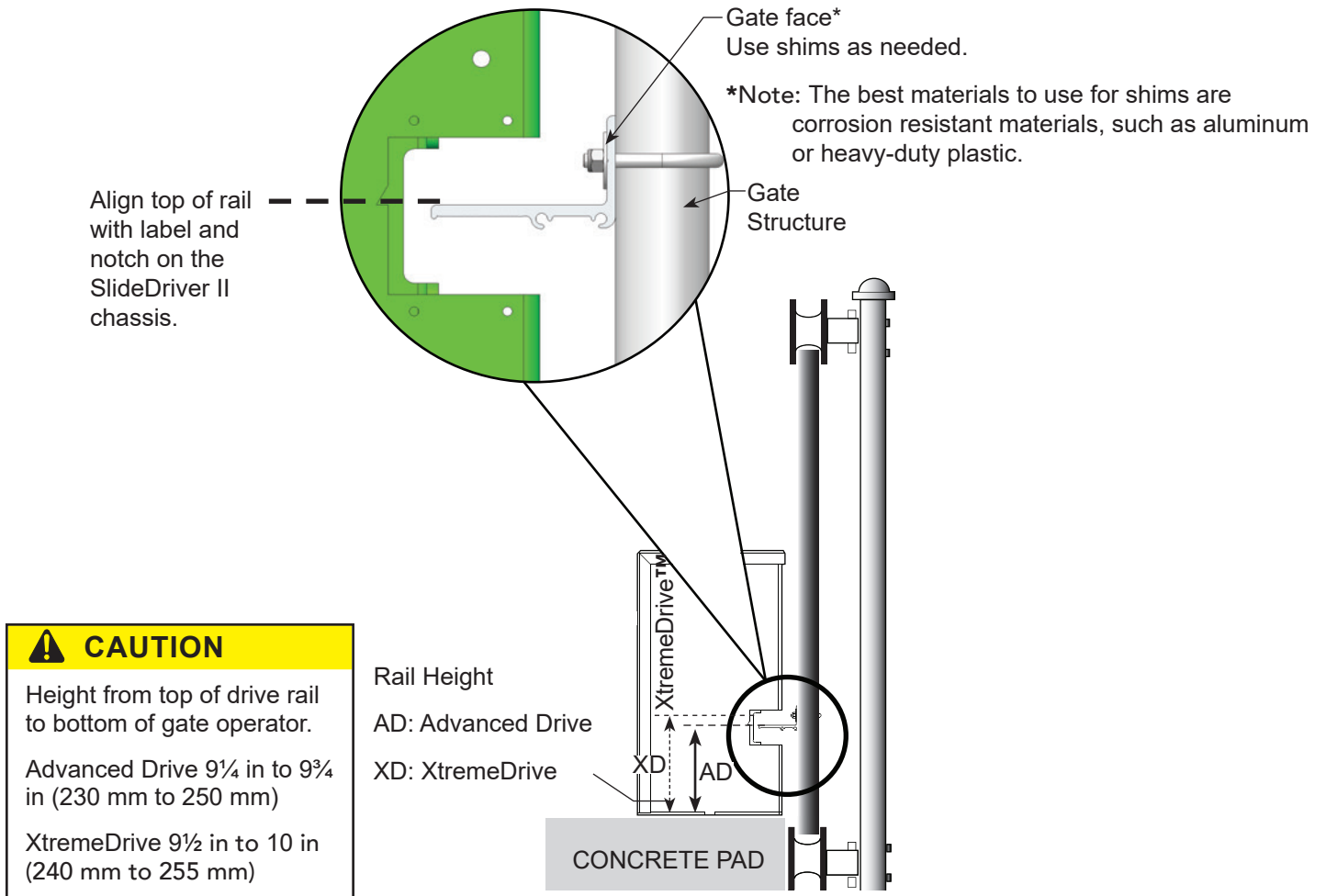

## Drive Wheel Spring Tension (Adjustment of Manual Release)

All SlideDriver II operators come equipped with a toggle handle manual release mechanism to disengage the drive wheels from the drive rail.

During shipment, a piece of Styrofoam is placed between the coupling nut and the chassis. If the packaging is still in place, discard it.

### **WARNING**

When releasing the handle inside the chassis, be careful as the mechanism is spring-loaded and drops rapidly. Grasp the toggle handle firmly so your fingers do not get pinched, hit, or crushed.

To disengage the drive wheels, pull the aluminum toggle handle down. As the lower drive wheel drops and disengages from the drive rail, it causes the coupling nut on the threaded rod to drop to its lowest position and push on the base of the operator. This causes the upper drive wheel to lift and disengage from the drive rail.

The coupling nut must be adjusted correctly so the wheels provide a strong clamping force on the drive rail. The red spring should measure 2 in (50 mm) in height when under the correct compression.

**Note:** If the drive rail is installed at the correct height to the chassis, the toggle release mechanism spreads both wheels equally in relation to the drive rail. If the drive rail has been mounted higher than specified, it may be necessary to use an additional coupling nut and  $\frac{3}{8}$  in bolt which can extend beyond the all thread and create additional lift clearance for the upper drive wheel when the toggle handle is released. If this extension method is used, adjust the  $\frac{3}{8}$  in bolt so the drive wheels spread equally when they are fully disengaged.

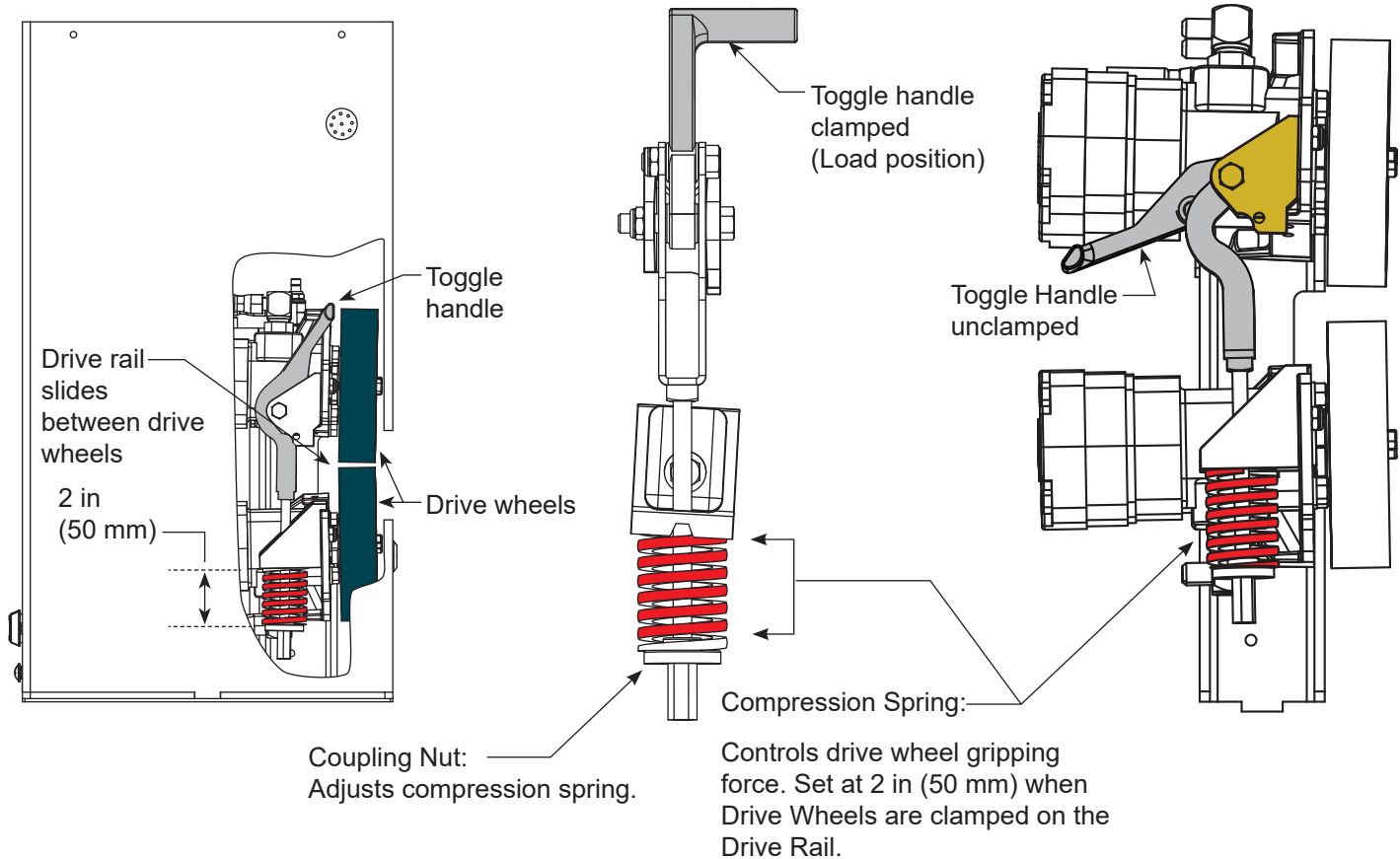

# MAINTENANCE

## Drive Wheel Assembly

Drive wheel assembly for AdvanceDrive™ and XtremeDrive™ is the same because they use the same wheel hub.

Note: Installation instructions are provided with the replacement drive wheels and are accessible online at [support.hysecurity.com](https://support.hysecurity.com).

A quick look at the drive wheel assembly is shown below. Tighten drive wheel mounting bolts to 18 ft-lb.

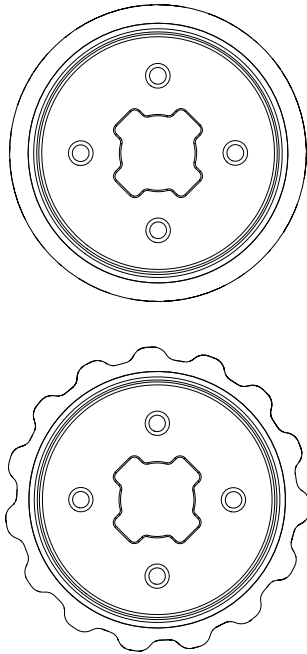

Figure 51. AdvanceDrive and XtremeDrive Wheels

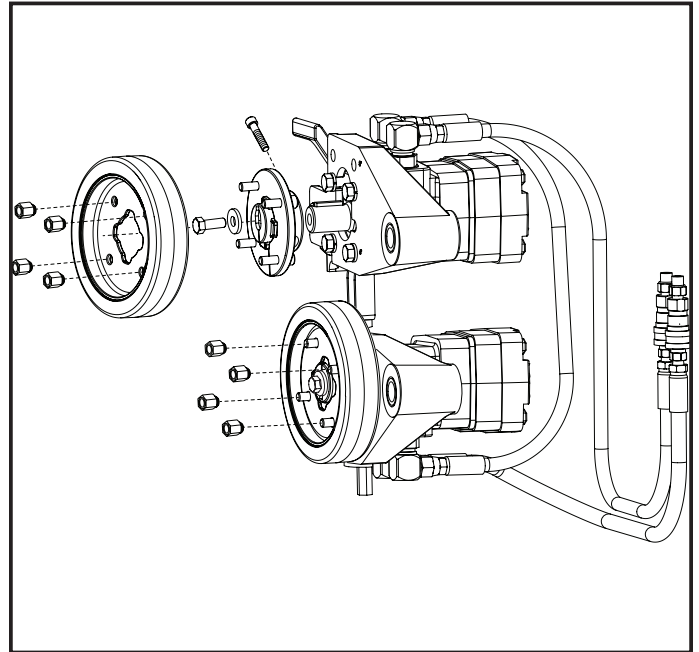

Figure 52. Mount the Drive Wheels

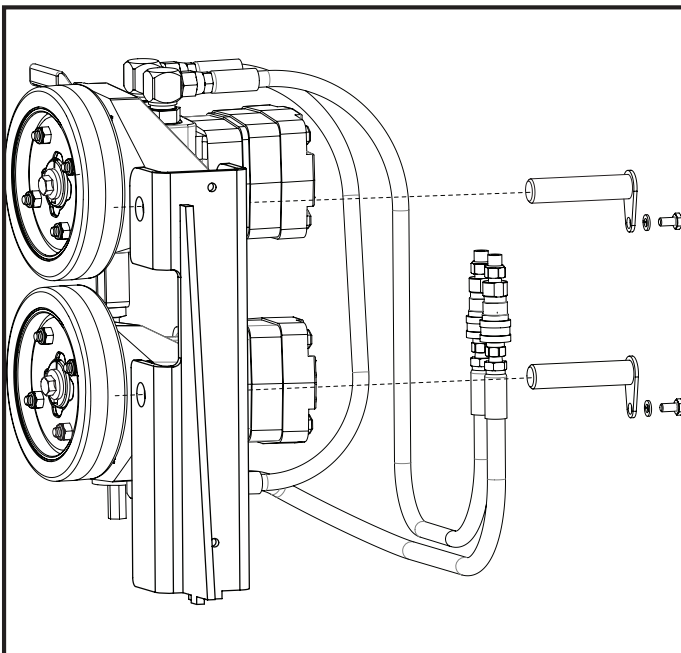

Figure 53. Mount the Pivot Arms

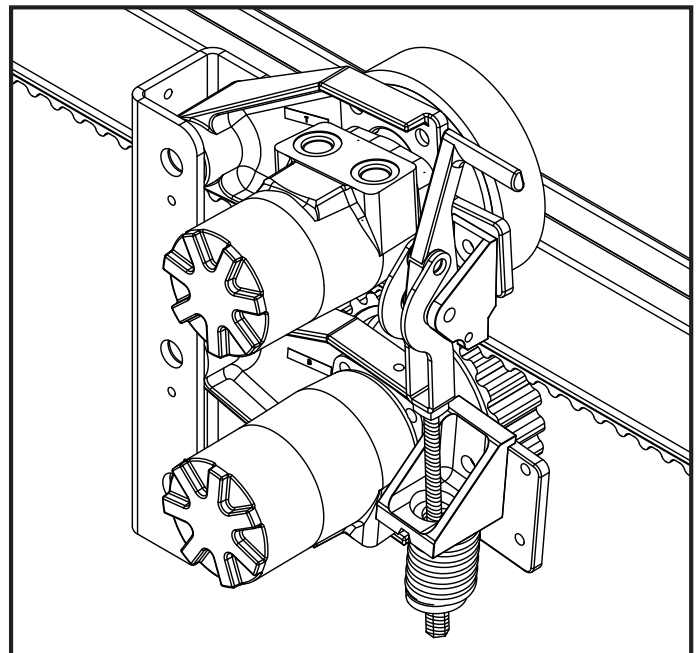

Figure 54. AdvanceDrive and XtremeDrive Wheel combo

## HYDRAULIC SYSTEM MAINTENANCE

**Fluid Level:** Under normal conditions, hydraulic systems do not consume fluid. Check the system thoroughly for leaks, before adding any fluid. If fluid needs to be added:

1. Remove the metal plug from the reservoir.
2. Use HySecurity Uniflow hydraulic fluid; part number MX000970. Gallon sold by our distributors.
3. Fill to within ½ in of the plug level, and then replace plug.

### NOTICE

Never use brake fluid. It will severely damage the hydraulic system. Use of any fluid other than fluid recommended by HySecurity may void the operator warranty.

**Look for leaks:** Occasionally there may be slight seeping at the fittings after some usage. Tightening of the fittings usually corrects the problem. If leaking persists, replace O-rings, fittings or hoses, if required. No further leaks should occur.

**To Change Fluid:** Unlike a gas engine, the fluid inside a hydraulic system does not foul, so fluid changes do not need to occur often. HySecurity recommends draining the reservoir and replacing the fluid at 24 month intervals. Fluid breakdown caused by heat is the main concern. If the unit is subjected to high use, or you are using the HySecurity biodegradable fluid option (especially in a warm climate), change the fluid more frequently.

To change the hydraulic fluid,

1. Remove the reservoir from the pump pack.
2. Completely empty it.
3. Wipe the reservoir clean and clean the debris screen.
4. Re-assemble the pump unit and refill it with new Uniflow hydraulic fluid.
5. To avoid overfilling, slowly pour the fluid through the filler port near the reservoir's top until the fluid is within one inch of the port's opening.
6. Replace the plug and wipe up any spilled fluid. Spilled fluid dries to a sticky and messy consistency.

### Cold Weather Issues:

1. Check that your reservoir is filled with our Uniflow high performance fluid.
2. Excessive ice buildup can partially or totally jam gate operation. Operate the gate manually, while clearing the ice buildup.
3. If the operator is located in an area of extreme snow conditions, regular maintenance to dig the operator out may be required. A heater option is recommended.

Note: A biodegradable fluid option does exist (part number MX002836), but it does not have the same fluid viscosity at extremely low temperatures. Uniflow fluid temperature rating is between -40°F and 158°F (-40°C and 70°C). The biodegradable fluid has a temperature rating between -10°F and 158°F (-23°C and 70°C).

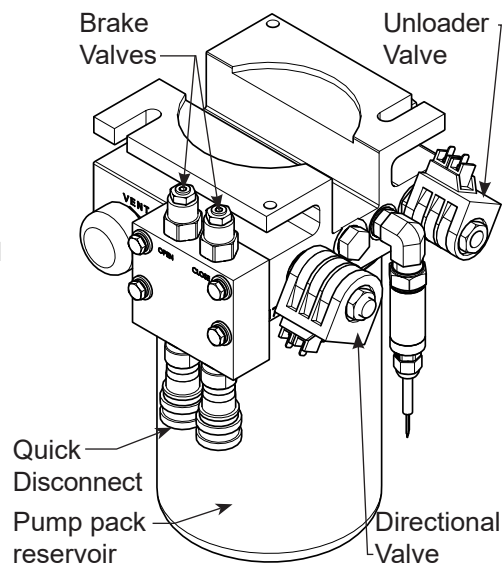

# MAINTENANCE

---

## Brake Valves

For SlideDriver II operators with adjustable brake valves proper adjustment of the brake valves is important for smooth operation of the gate (not all SlideDriver II operators have adjustable brake valves). The position and placement of the limit flags on the drive rail plays an important part on how the brake valves work.

Adjustment of the brake valves, one for each direction of travel, will determine how quickly the gate actually stops. If adjustment is needed, loosen the  $\frac{9}{16}$  in lock nut on the top of the brake valve and make  $\frac{1}{4}$  in incremental turns on the adjustment stem with a  $\frac{5}{32}$  in hex key. Loosen to increase braking, tighten to decrease braking. Test cycle the gate after each incremental turn. See “Adjust the Brake Valves (SD40, 50F, 80V, 200V)” on page 37.

## Pressure Relief Valve

DO NOT adjust the pressure relief valve. The pressure relief valve governs the maximum system hydraulic pressure. It is located on the backside of the pump. The pressure relief valve is factory set.

## Unloader Valve

Only on SlideDriver II 15 and SlideDriver II 40. Allows the motor to start with no hydraulic load.

## Directional Valve

The directional valve is solenoid operated and, when energized, directs the hydraulic flow to open the gate. No adjustment of this valve is possible or necessary. The black solenoid coil mounts on its valve stem.

## ELECTRICAL SAFETY

- Turn gate operator and all circuit breakers OFF before performing maintenance on the gate operator or making contact with output receptacles.
- Never insert any objects into output receptacles during operation. The possibility exists of electrical shock, electrocution, or death.
- Never let power wires lay in water.
- Never use damaged or worn wire when connecting equipment. Inspect for cuts in the insulation.
- Never grab or touch a live power cord or cable with wet hands. The possibility exists of electrical shock, electrocution or death.
- Always make certain that proper power has been selected for the job. See Cable Selection Chart in this manual.

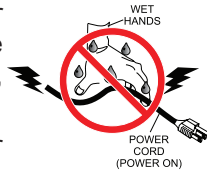

## GROUNDING SAFETY

- Always make sure that electrical circuits are properly grounded to a suitable earth ground (ground rod) per the National Electrical Code (NEC) and local codes. Severe injury or death by electrocution can result from operating an ungrounded operator.
- Never use gas piping as an electrical ground.



## BATTERY SAFETY

HySecurity operators use sealed Absorbed Glass Mat (AGM) batteries and HySecurity highly recommends replacing used batteries with new AGM-type batteries.

### CAUTION

Batteries used with HySecurity gate operator contain materials considered hazardous to environment. Proper battery disposal is required by federal law. Refer to *Hazardous Waste Regulations* federal guidelines.

## To reduce risk of fire or injury to persons:

- Observe polarity between batteries and charging circuit.
- Never mix battery sizes, types, or brands. Charging circuit on HySecurity DC operators is designed for AGM-type batteries, not flooded lead acid-type batteries.
- Exercise care in handling batteries. Be aware metal found in rings, bracelets, and keys can conduct electricity, short batteries, and cause potential injury.
- Do not open or mutilate batteries. Battery cells contain corrosive materials which may cause burns and other injuries. Material within batteries is toxic.
- Always dispose of batteries properly. Do not place batteries in fire. Battery cells may explode. Follow federal guidelines for proper disposal of hazardous waste.
- Always keep battery cables in good working condition. Repair or replace all worn cables.
- Replace batteries according to instructions found in *DC Battery Replacement*.
- Do not charge frozen battery. Battery can explode. If frozen, warm the battery to at least 61°F (16°C).



## ENVIRONMENTAL SAFETY/HAZARDOUS MATERIALS AND PROPER DISPOSAL

Decommissioning is a controlled process used to safely retire a piece of equipment that is no longer serviceable. If the equipment poses an unacceptable and unrepairable safety risk due to wear or damage or is no longer cost effective to maintain (beyond life-cycle reliability) and is to be decommissioned (demolition and dismantlement), be sure to follow rules below.



- Do not pour waste or oil directly onto the ground, down a drain or into any water source.
- Contact your country's Department of Public Works or recycling agency in your area and arrange for proper disposal of any electrical components, waste or oil associated with this equipment.
- When the life cycle of this equipment is over, remove battery and bring to appropriate facility for lead reclamation. Use safety precautions when handling batteries that contain sulfuric acid.
- When the life cycle of this equipment is over, it is recommended that the frame and all other metal and plastic parts be sent to a recycling center.

Metal and plastic recycling involves the collection of metal and plastic from discarded products and its transformation into raw materials to use in manufacturing a new product.

Recyclers and manufacturers alike promote the process of recycling metal and plastic. Using a metal and plastic recycling center promotes energy cost savings.



# TROUBLESHOOTING/ALERTS/FAULTS/ERRORS

**Table 27. SmartTouch 720/725 Controller - Troubleshooting**

Display Condition	Description Alert, Error or Fault	Possible Causes	Solutions
SAFE MODE	Safe Mode Alert	Occurs when an edge sensor or Inherent Entrapment Sensor (IES) trips. Gate binding, wind, or a faulty edge sensor can cause a false alert. All inputs are still functional during safe mode, but Close Timer is disabled until an operate command is received.	<ol style="list-style-type: none"> <li>1. Activate any operate command.</li> <li>2. Remove obstruction.</li> <li>3. Correct gate hardware.</li> <li>4. Correct faulty edge sensor.</li> <li>5. Adjust IES sensitivity.</li> </ol>
ENTRAPMENT MODE	Entrapment Mode Alert	<p>Occurs when IES is tripped when gate is already in Safe Mode (two IES trips in one cycle). Operator will not function until it is reset, which can occur by:</p> <ul style="list-style-type: none"> <li>• An Open or Stop command from a push-button control</li> <li>• Pressing STOP button on operator side</li> <li>• Pressing RESET button below display</li> </ul> <p>Gate binding, wind, or a faulty edge sensor can cause a false alert. Emergency Close or Fire Open input activation will also stop the gate in Entrapment Mode.</p>	Refer to solutions above.
NO AC POWER	No AC Input Power Advisory only.	AC power is shut off at source (breaker) or is not connected. AC power switch on operator (lower rocker switch) is turned off. Verify relay output from DC Charger is connected to input 8 of the I/O Expansion Module when operator is configured for DC power.	<ol style="list-style-type: none"> <li>1. Reset operator circuit breaker or reset circuit breaker at electrical panel.</li> <li>2. Verify AC power to battery backup system. Have a licensed electrician check wiring.</li> <li>3. Verify Power Type Setting is correct.</li> </ol>
LOADING FW	Firmware is being loaded into SmartTouch 720/725 Controller.	Firmware is currently being loaded. Display will show which specific processor firmware is loading.	Wait for firmware to finish loading.



# TROUBLESHOOTING/ALERTS/FAULTS/ERRORS

**Table 27. SmartTouch 720/725 Controller - Troubleshooting**

Display Condition	Description Alert, Error or Fault	Possible Causes	Solutions
LOW 24VDC	Low 24VDC UPS Batteries Advisory only.	<p>Occurs when battery voltage has dropped to less than 22V. At this level, batteries have about 20% charge. Normal function until 21V.</p> <ul style="list-style-type: none"> <li>● No AC Power</li> <li>● Wiring / Connector problem</li> </ul>	<ol style="list-style-type: none"> <li>1. Verify AC power.</li> <li>2. Check all connections. Clean or repair as required.</li> <li>3. Check battery condition and replace as required.</li> <li>4. Check charger voltage is 27VDC at red/blue battery wires.</li> </ol>
DEAD BATTERY	Extremely low UPS batteries – no automatic operation - batteries below 21V.	<p>Occurs when battery voltage has dropped to less than 21V. At this level, batteries have about 10% charge. Gate will automatically open or close depending upon setting chosen. No additional automatic function is possible, but limited push button control is available down to 18V.</p>	Refer to solutions above.
HYSECURITY BAD POWER	Critically low 24V supply power. This message can occur only on initial start up if power is critically low.	DC power is below 14V – no control functions will be allowed at all.	Refer to solutions above.
No display, LED blinking	<p>SmartTouch 720/725 Controller is in standby.</p> <p>SmartTouch 720/725 Controller is receiving power, but battery voltage is very low.</p>	<p>Several possible causes:</p> <ul style="list-style-type: none"> <li>● SmartTouch 720/725 controls have been inactive for at least 10 minutes and the display has been disabled. Any button push will turn display back on.</li> <li>● AC power has been shut off from the operator for too long and the batteries are drained.</li> <li>● Wiring problem.</li> <li>● 24V output shorted or drawing too much current.</li> <li>● Batteries no longer hold a charge.</li> <li>● Failed SmartTouch 720/725 Controller.</li> <li>● Disconnected com (HSP) wire between SmartTouch 720/725 Controller and I/O Expansion Module or VFD.</li> </ul>	<p>Press any button to wake display.</p> <p>Refer to solutions above.</p>

# TROUBLESHOOTING/ALERTS/FAULTS/ERRORS

**Table 28. SmartTouch 720/725 Controller - Alerts**

Display Condition	Description Alert, Error or Fault	Possible Causes	Solutions
ALERT 1 FORCE OPEN	Gate forced open. Alarm will sound.	Gate has been forced off the full close limit and is being prevented from re-closing.	Will self-clear after an open or close input.
ALERT 2 DRIFT CLOSED	Gate drifted closed.	Gate has drifted off the full open limit and is being prevented from re-opening.	Will self-clear after an open or close input.
ALERT 4 MOTOR OVERLOAD	Thermal overload alert. When alert is triggered, gate can only “fully open” until alert is cleared.	For AC operators, the AC motor has a thermal switch that is NC connected to input 8 of the I/O Expansion Module or input 1 of the VFD. When this opens the Alert 4 is declared.	Auto clears when thermal switch input closes and a run command is given.
ALERT 5 BOTH LIM ACTIVE	Both limit sensors are on at the same time	<ul style="list-style-type: none"> <li>Limits sensors not connected correctly</li> <li>Failed limit sensor</li> </ul>	<ul style="list-style-type: none"> <li>Repair any wiring issues.</li> <li>Check limit sensors and replace as required.</li> </ul>
ALERT 6 LIM NOT RELEASED	The limit did not release when the operator was commanded to move.	<ul style="list-style-type: none"> <li>Wheels are not clamped</li> <li>3 Phase electric motor may be spinning wrong direction</li> <li>No hydraulic pressure or flow.</li> <li>Failed limit sensor</li> </ul>	<ul style="list-style-type: none"> <li>Ensure wheels are properly clamped to drive rail</li> <li>Check limit sensors and replace as required</li> <li>Verify electric motor is spinning the right direction</li> </ul>
ALERT 7 FREQ SHIFT FAULT*	Hy5B detects a frequency change outside normal range.	Likely causes are poor integrity of loops or metallic objects within range.	Check lead-in and roadway loop wires for problems. Replace if necessary.
ALERT 8 LOOP SHORTED*	Hy5B detects a loop shorted to ground.	Caused by inadequate insulation of loop wires.	Refer to solution above.
ALERT 9 LOOP OPEN*	Hy5B detects a lack of continuity in loop wire.	Caused by broken loop wire or wire has come unplugged from detector.	Refer to solution above.
ALERT 10 I2C BUS ERROR*	Communication error detected to a Hy5B vehicle detector.	Caused by removal of Hy5B or lack of integrity of socket connection.	Remove and re-install the Hy5B and press RESET. Replace Hy5B, if necessary.
ALERT 11 DETECTOR FAULT*	A problem detected within an Hy5B vehicle detector.	Caused by a fault within Hy5B.	Remove and re-install the Hy5B and press RESET. Replace Hy5B, if necessary.
ALERT 12 ON TOO LONG*	An input loop (Hy5B or box detector output) is active for more than 5 minutes.	Caused when SmartTouch 720/725 Controller sees an active loop for more than 5 minutes. “Active” loop can be actual or false.	Check traffic patterns at site. Loop and lead in wires should be checked for problems or replaced.

\* This message will also indicate which detector the alert applies to: Exit Loop (ELD), Inside Obstruction Loop (IOLD), Outside Obstruction Loop (OOLD), or Center Loop (CLD).

# TROUBLESHOOTING/ALERTS/FAULTS/ERRORS

**Table 28. SmartTouch 720/725 Controller - Alerts**

Display Condition	Description Alert, Error or Fault	Possible Causes	Solutions
ALERT 16 I2C FAILURE		SmartTouch 720/725 has detected an internal communications error. <ul style="list-style-type: none"> <li>● Excessive electrical noise.</li> <li>● Lack of earth grounding.</li> <li>● Internal problem on SmartTouch 720/725.</li> </ul>	<ol style="list-style-type: none"> <li>1. Determine and remedy source of electrical noise.</li> <li>2. Install a ground rod.</li> <li>3. Replace SmartTouch 720/725.</li> </ol>
ALERT 17 BAD COIN BATTERY	2 chirps per second every 15 seconds	Small battery on SmartTouch 720/725 is loose or needs replacing.	<ol style="list-style-type: none"> <li>1. Verify that the battery is properly seated.</li> <li>2. Replace coin battery. Use a CR2032 coin battery.</li> <li>3. Restore power.</li> <li>4. Press RESET button.</li> </ol>
ALERT 19 FALSE SLOWDOWN SIGNAL (OT7 ONLY)	2 chirps per second every 15 seconds	Appears only on SD50F operators. Slowdown sensor tripped and released (less than 1 second) in middle of run. Check for loose wires, limits and misaligned rails or limit ramps or wrong slowdown switch was tripped, so open slow down in close direction.	Check handing setting and hoses are connected correctly. Verify limit sensor is centered on limit flag in stop position.
ALERT 20 LI BLOCK OPEN		An interlock contact is closed, indicating that the gate latch (lock) is engaged, preventing the operator from starting.	<ol style="list-style-type: none"> <li>1. Check the interlock terminal and wiring.</li> <li>2. Verify proper User Relay option is used.</li> </ol>
ALERT 21 VFD TRIPPED	2 chirps per second every 15 seconds	Alert indicates the VFD has experienced a hardware or firmware fault. Gate travel will not occur until the alert is cleared. Any open or close command resets the alert and starts the gate moving, unless the VFD is experiencing a fatal error. If you cannot clear the error alert by pressing the open or close button, contact HySecurity.	
ALERT 22 INTLOCK FAILURE	Interlock/Sequential Gate communication lost.  Alert auto clears when communication between two operators is restored.	<ul style="list-style-type: none"> <li>● Appears when communication connection is lost for more than 5 seconds between interlocked or sequenced gate operators.</li> <li>● Solo operator has Sequential gate set to ON.</li> </ul>	<ol style="list-style-type: none"> <li>1. Check cable connections and wiring. Make sure both operators are working properly with compatible firmware versions.</li> <li>2. Verify Dual Gate and Sequential Gate are both set to (0) on a solo operator.</li> </ol>

# TROUBLESHOOTING/ALERTS/FAULTS/ERRORS

**Table 29. SmartTouch 720/725 Controller - Faults**

Display Condition	Description Alert, Error or Fault	Possible Causes	Solutions
FAULT 1 MOTOR RUN TIME	The motor is on longer than the maximum run time selected.	<ul style="list-style-type: none"> <li>• Drive Wheels not clamped properly or Limit Sensor Failed.</li> <li>• May not be enough hydraulic fluid.</li> </ul>	<ol style="list-style-type: none"> <li>1. Ensure wheels are clamped.</li> <li>2. Check limit sensors. Replace as required.</li> <li>3. Increase Max Run Timer.</li> </ol>
FAULT 2 SENSOR or INPUT #	Monitored sensor is missing or not working.	<p>This fault can only occur if monitored sensor check fails.</p> <p>Display will show SENSOR 1, SENSOR 2, INPUT 1, INPUT 2, or INPUT 3.</p>	<ol style="list-style-type: none"> <li>1. Check monitored sensor is connected to SENSOR 1 OR SENSOR 2 COM.</li> <li>2. Correct malfunctioning monitored sensor.</li> </ol>
FAULT 5 LIMIT FAILED (SlideDriver II 50F only)	Stop limit flag not detected after slow down limit flag.	Stop limit flag is not detected within 5 seconds of slowdown limit flag.	<ol style="list-style-type: none"> <li>1. Verify limits and placement of slow down limit flags.</li> <li>2. With drive wheels clamped, test Open (GATE OPENING appears on display). Test Close (GATE CLOSING appears on display).</li> </ol>
FAULT 6 HYINVERTER OVERLOAD	2 chirps per second once per minute	Excess output load on the AC power supply with HyInverter AC causing power loss.	<ol style="list-style-type: none"> <li>1. Check gate hardware for binding (ice, poorly maintained gate, etc.).</li> <li>2. Check start/stop switch on 1 hp motor gate operators.</li> </ol>
FAULT 9 PROCESSOR COMMUNICATION	2 chirps per second once per 15 seconds	Failed communication between the main HySecurity microprocessor and the processor that controls BlueBUS and OXI accessories.	<ol style="list-style-type: none"> <li>1. Cycle power.</li> <li>2. Replace the SmartTouch 720/725 Controller.</li> </ol>

# TROUBLESHOOTING/ALERTS/FAULTS/ERRORS

**Table 30. SmartTouch 720/725 Controller - Errors**

Display Condition	Description Alert, Error or Fault	Possible Causes	Solutions
ERROR 1 DIRECTION ERROR	SmartTouch 720/725 Controller detects operator ran in wrong direction.	<ul style="list-style-type: none"> <li>• Limit sensors wired incorrectly or limit flags installed in wrong location.</li> <li>• Hydraulic Hoses may also be connected to wrong spots.</li> </ul>	<ol style="list-style-type: none"> <li>1. Check Limit Sensor wires and limit flag alignment.</li> <li>2. Check Hydraulic hose connections</li> <li>3. Press RESET to clear fault.</li> </ol>
ERROR 2 IES DISCONNECT	Pressure Transducer disconnected or not functional.	<ul style="list-style-type: none"> <li>• The pressure transducer could be bad.</li> <li>• Loose sensor wires.</li> <li>• Check that you have the most current sensor; visit <a href="http://support.hysecurity.com">support.hysecurity.com</a> and view the technical bulletins.</li> <li>• Verify the version of the firmware by pressing the Reset button. The firmware version appears on the display. Make a note of it. The firmware version should be h6.## (or later).</li> </ul>	Check to see that the pressure transducer is connected properly.
ERROR 3 Hy5B FAILED*	SmartTouch 720/725 Controller detects communication error with a Hy5B vehicle detector.	Caused by Hy5B removal or socket connection integrity.	<ol style="list-style-type: none"> <li>1. Press RESET.</li> <li>2. Remove and re-install Hy5B.</li> <li>3. Replace Hy5B, if needed.</li> </ol>
ERROR 4 PRIMARY- SECONDARY COM	SmartTouch 720/725 Controller detects a communication error between primary and secondary in a dual gate installation.	<p>Several possible causes:</p> <ul style="list-style-type: none"> <li>• Primary/Secondary communication cable is installed incorrectly.</li> <li>• Primary/Secondary not configured properly through Installer Menu.</li> <li>• Operator is not properly earth grounded.</li> <li>• Primary/Secondary communication cable installed in same conduit as high-voltage AC power.</li> <li>• One operator is powered off.</li> <li>• Different firmware versions between operators. Check firmware version currently loaded in operator by pressing RESET.</li> <li>• Dual gate enabled on a solo operator.</li> </ul>	<ol style="list-style-type: none"> <li>1. Correct communication cable.</li> <li>2. Verify one operator is set as Primary and the other is set as Secondary.</li> <li>3. Install ground rod per NEC/NFPA standard.</li> <li>4. Install communication cables in a low voltage conduit.</li> <li>5. Ensure AC power is present at both operators and all power switches are On.</li> <li>6. Make sure both operators are running same firmware version.</li> </ol>

\* This message will also indicate which detector the alert applies to: Exit Loop (ELD), Inside Obstruction Loop (IOLD), Outside Obstruction Loop (OOLD), or Center Loop (CLD).

# TROUBLESHOOTING/ALERTS/FAULTS/ERRORS

**Table 30. SmartTouch 720/725 Controller - Errors**

Display Condition	Description Alert, Error or Fault	Possible Causes	Solutions
ERROR 5 No display	Display is blank, but the error appears in the log and means that SmartTouch 720/725 Controller detects a serious internal error.	Internal firmware/hardware error. Report any instance of this error to HySecurity Technical Support.	<ol style="list-style-type: none"> <li>1. Set power switch to OFF and then to ON.</li> <li>2. Update to latest firmware version.</li> <li>3. Replace SmartTouch 720/725 Controller.</li> </ol>
ERROR 6 DRIVE BOARD COMM	Indicates communication failure between VFD and SmartTouch 720/725 Controller.	Communication with the VFD has failed (OT7 only)	Ensure VFD wiring is attached and VFD/ SmartTouch 720/725 boards are programmed correctly
ERROR 7 MENU CHECKSUM	Firmware issue exists that may require factory reset.	Corrupt firmware or data.	Call HySecurity Technical Support for assistance.
ERROR 10 SLOWDOWN SWITCH (SlideDriver II 50F only)	Slowdown limit failed	The operator tripped the fully Open or Close limit before the Slowdown limit tripped.	Check slow down limit flag alignment with limit sensor.
ERROR 13 HYINVERTER COMMUNICATION	3 chirps per second once per minute	Communication does not exist between the AC power supply with HyInverter AC and the SmartTouch 720/725 Controller in the gate operator.	<ol style="list-style-type: none"> <li>1. Check communication wires are connected and working properly.</li> <li>2. Verify that your operator has the current firmware.</li> <li>3. If communication is not desired between HyInverter AC and SmartTouch 720/725 Controller, then set Power Type setting to 1 instead of 3.</li> </ol>
ERROR 15 I/O Expansion Module	2 chirps every 15 seconds	Communication is not present between the SmartTouch 720/725 Controller and the I/O Expansion Module. The I/O Expansion Module is standard in the SD15 and SD40, so it should always be present and communicating with the SmartTouch 720/725 Controller. For the SD50F, SD80V, and SD200V, check that the programmable inputs and user relays are not set for the I/O Expansion Module inputs and outputs if an I/O Expansion Module is not used.	<ol style="list-style-type: none"> <li>1. Check wiring between SmartTouch 720/725 Controller and I/O Expansion Module.</li> <li>2. Check that the user relays and programmable inputs are programmed correctly and that an I/O Expansion Module is present.</li> </ol>

# APPENDIX A - FRENCH TRANSLATIONS

## FRENCH TRANSLATIONS

The following French translations provided below are found in the Safety Section located at the beginning of the manual.

English	French
IMPORTANT SAFETY INSTRUCTIONS WARNING – To reduce the risk of injury or death:	INSTRUCTIONS DE SÉCURITÉ IMPORTANTES AVERTISSEMENT – Pour réduire les risques de blessures et de mort :
1. READ AND FOLLOW ALL INSTRUCTIONS.	1. LISEZ CETTE NOTICE ET CONFORMEZ-VOUS AUX MISES EN GARDE
2. Never let children operate or play with gate controls. Keep the remote control away from children.	2. Ne laissez jamais les enfants manoeuvrer les commandes de la barrière ou jouer avec celles-ci. Laissez la télécommande hors de la portée des enfants.
3. Always keep people and objects away from the gate. NO ONE SHOULD CROSS THE PATH OF THE MOVING GATE.	3. Tenez toujours à l'écart de la barrière toute personne ou tout objet avoisinant. IL NE FAUT JAMAIS PASSER DANS LA TRAJECTOIRE D'UNE BARRIÈRE EN MOUVEMENT.
4. Test the gate operator monthly. The gate MUST reverse on contact with a rigid object or stop when an object activates the non-contact sensors. After adjusting the force or the limit of travel, retest the gate operator. Failure to adjust and retest the gate operator properly can increase the risk of injury or death.	4. Vérifiez le fonctionnement de l'ouvre-barrière une fois par mois. Le sens de la course DOIT s'inverser lorsque la barrière entre en contact avec un objet dur ou la barrière DOIT s'arrêter lorsqu'un objet active les capteurs sans contact. Vérifiez à nouveau l'ouvre-barrière après tout réglage de la force de déclenchement ou du seuil de fin de course. Un réglage incorrect de l'ouvre-barrière ou l'omission de vérifier à nouveau le fonctionnement de l'ouvre-barrière peut causer des blessures, voire la mort.
5. Use the emergency release only when the gate is not moving.	5. Ne déclenchez le dispositif de désaccouplement d'urgence que lorsque la barrière ne bouge pas.
6. KEEP GATES PROPERLY MAINTAINED. Read the user's manual. Have a qualified service person make repairs to gate hardware.	6. ASSUREZ-VOUS QUE LA BARRIÈRE EST CORRECTEMENT ENTRETENUE. Lisez le manuel de l'utilisateur. Confiez la réparation du matériel de la barrière à un technicien qualifié.
7. The entrance is for vehicles only. Pedestrians must use separate entrance.	7. La voie d'accès est réservée aux véhicules seulement. Les piétons doivent utiliser une voie d'accès différente.
8. SAVE THESE INSTRUCTIONS.	8. CONSERVEZ CES INSTRUCTIONS.



## APPENDIX A - FRENCH TRANSLATIONS

English	French
2.3 Install the gate operator only when:	2.3 N'installez l'ouvre-barrière que si :
a. The operator is appropriate for the construction of the gate and the usage Class of the gate,	a. l'ouvre-barrière est approprié pour la structure et la classe d'utilisation de la barrière;
b. All openings of a horizontal slide gate are guarded or screened from the bottom of the gate to a minimum of 1.83 m (6 ft) above the ground to prevent a 57.2 mm (2-1/4 inch) diameter sphere from passing through the openings anywhere in the gate, and in that portion of the adjacent fence that the gate covers in the open position,	toutes les ouvertures de la barrière coulissante sont protégées ou grillagées du bas de la porte jusqu'à un minimum de 1,83 m (6 pi) du sol si bien qu'une sphère de 57,2 mm (2 1/4 po) de diamètre ne peut passer par une ouverture au niveau de la barrière et de la portion de la clôture adjacente que la barrière couvre en position ouverte;
c. All exposed pinch points are eliminated or guarded, and	c. tous les points de pincement sont éliminés ou protégés;
d. Guarding is supplied for exposed rollers.	d. des protections sont fournies pour les galets exposés.
2.4 The operator is intended for installation only on gates used for vehicles. Pedestrians must be supplied with a separate access opening. The pedestrian access opening shall be designed to promote pedestrian usage. Locate the gate such that persons will not come in contact with the vehicular gate during the entire path of travel of the vehicular gate.	2.4 L'ouvre-barrière est destiné à n'être installé que sur des barrières utilisées pour les véhicules. Il faut fournir une autre voie d'accès aux piétons. La voie d'accès pour les piétons doit être conçue pour favoriser le passage des piétons. Placez la barrière de sorte que personne ne puisse entrer en contact avec la barrière pour les véhicules sur l'ensemble de sa trajectoire
2.5 The gate must be installed in a location so that enough clearance is supplied between the gate and adjacent structures when opening and closing to reduce the risk of entrapment. Swinging gates shall not open into public access areas.	c) Pour réduire les risques de coincement lors de l'ouverture et de la fermeture, la barrière doit être installée dans un endroit où la barrière et les structures avoisinantes sont suffisamment éloignées l'une de l'autre. Les barrières battantes ne doivent pas ouvrir dans une zone d'accès public.



## APPENDIX A - FRENCH TRANSLATIONS

English	French
2.6 The gate must be properly installed and work freely in both directions prior to the installation of the gate operator. Do not over-tighten the operator clutch or pressure relief valve to compensate for a damaged gate.	2.6 La barrière doit être bien installée et fonctionner librement dans les deux directions avant d'entreprendre l'installation de l'ouvre-barrière. Ne serrez pas trop l'embrayage ou la soupape de surpression de l'ouvre-barrière pour compenser une barrière endommagée.
2.7 Controls intended for user activation must be located at least 1.83 m (6 ft) away from any moving part of the gate and where the user is prevented from reaching over, under, around or through the gate to operate the controls. Exception: Emergency access controls only accessible by authorized personnel (e.g. fire, police, EMS) may be placed at any location in the line-of-sight of the gate.	2.7 Les commandes destinées à l'activation par l'utilisateur doivent être situées à au moins 1,83 m (6 pi) des pièces mobiles de la barrière et à un endroit où l'utilisateur ne peut pas atteindre les commandes par le dessus, par le dessous, par les côtés et au travers de la barrière. Exception : Les commandes d'accès d'urgence accessibles au personnel autorisé seulement (p. ex. pompier, policier, SMU) peuvent être placées à tout endroit dans le champ de visibilité de la barrière.
2.8 The Stop and/or Reset button must be located in the line of-sight of the gate. Activation of the reset control shall not cause the operator to start.	2.8 Le bouton d'arrêt, le bouton de réenclenchement ou ces deux boutons doivent être situés dans le champ de visibilité de la barrière. L'activation des commandes de réenclenchement ne doit pas mettre en marche l'ouvrebarrière.
2.9 A minimum of two (2) WARNING SIGNS shall be installed, in the area of the gate. Each placard is to be visible by persons located on the side of the gate on which the placard is installed.	2.9 Au moins deux panneaux de mise en garde doivent être installés dans la zone de la barrière. Chaque étiquette doit être visible des personnes situées de chaque côté de la barrière sur laquelle l'étiquette est installée.
2.10 For gate operators utilizing a non-contact sensor	2.10 Pour les ouvre-barrières qui fonctionnent avec des capteurs
a. See instructions on the placement of non-contact sensors for each Type of application,	a. Voir les instructions sur le positionnement des capteurs sans contact pour chaque type d'utilisation.
b. Care shall be exercised to reduce the risk of nuisance tripping, such as when a vehicle, trips the sensor while the gate is still moving, and	b. Des précautions doivent être prises pour réduire les risques de déclenchement inutile, comme lorsqu'un véhicule déclenche le capteur alors que la barrière est encore en mouvement.
c. One or more non-contact sensors shall be located where the risk of entrapment or obstruction exists, such as the perimeter reachable by a moving gate or barrier.	c. Un capteur sans contact ou plus doit être situé où il existe un risque de coincement ou d'obstruction, comme dans l'espace que peut occuper la barrière lorsqu'elle est en mouvement.
2.11 For a gate operator utilizing a contact sensor	2.11 Pour les ouvre-barrières qui fonctionnent avec des capteurs

## APPENDIX A - FRENCH TRANSLATIONS

English	French
a. One or more contact sensors shall be located where the risk of entrapment or obstruction exists, such as at the leading edge, trailing edge, and postmounted both inside and outside of a vehicular horizontal slide gate.	a. Au moins un capteur de contact doit être situé où il existe un risque de coincement ou d'obstruction, comme sur le bord d'ouverture, sur le bord de fermeture et sur les poteaux montés sur l'intérieur ou l'extérieur d'une barrière coulissante pour véhicules.
b. A hardwired contact sensor shall be located and its wiring arranged so that the communication between the sensor and the gate operator is not subjected to mechanical damage.	b. Un capteur de contact doit être installé et câblé de sorte à éviter que la communication entre le capteur et l'ouvrebarrière soit gênée par des dommages mécaniques.
c. A wireless device such as one that transmits radio frequency (RF) signals to the gate operator for entrapment protection functions shall be located where the transmission of the signals are not obstructed or impeded by building structures, natural landscaping or similar obstruction. A wireless device shall function under the intended end-use conditions.	c. Un dispositif sans fil, comme un appareil qui transmet des signaux de radiofréquence (RF) à l'ouvre-barrière pour prévenir le coincement, doit être situé à un endroit où la transmission des signaux ne sera pas obstruée ou gênée par des structures, des arbres ou d'autres obstacles similaires. Un dispositif sans fil doit fonctionner selon les conditions d'utilisation finale prévues.
d. One or more contact sensors shall be located on the inside and outside leading edge of a swing gate. Additionally, if the bottom edge of a swing gate is greater than 152 mm (6 inches) but less than 406 mm (16 inches) above the ground at any point in its arc of travel, one or more contact sensors shall be located on the bottom edge.	d. Au moins un capteur de contact doit être situé sur les bords d'ouverture intérieur et extérieur d'une barrière battante. De plus, si le dessous d'une barrière battante est situé à plus de 152 mm (6 po) mais à moins de 406 mm (16 po) du sol à l'un des points de sa trajectoire, au moins un capteur de contact doit être situé sur le bord inférieur.

## SNOW KIT INSTRUCTIONS

The snow brush and snow scraper kits help keep ice and snow buildup at a minimum along the drive rail of the SlideDriver II gate operators.

Note: The snow brush and snow scraper kits can be ordered together or separately. These instructions explain the installation process for both.

### PARTS

- Snow brushes and/or snow scrapers

### HARDWARE

- 1/4-20 x 3/4 hex head cap screw
- 1/4 in flat washer
- 1/4-20 lock nut
- 8-32 x 1/2 self-tapping screw

### TOOLS

- Phillips-head screwdriver
- Wrench

## INSTALL THE SNOW BRUSHES

1. Loosen the screws that secure the cover to the SlideDriver II chassis and remove the cover.
2. Set the power switch to OFF.
3. Slide the snow brushes into place and secure them using the fasteners provided. The aluminum flange should be inside the operator (Figure 3 and Figure 6).
4. Set the power switch to ON.
5. Test the gate operator.
6. Carefully replace the cover and secure it to the chassis.

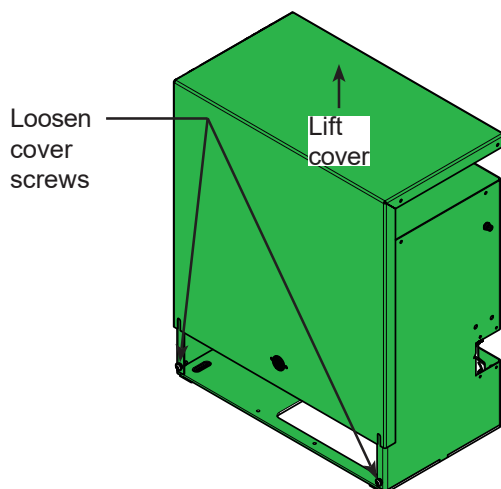

Figure 1. Remove the Cover

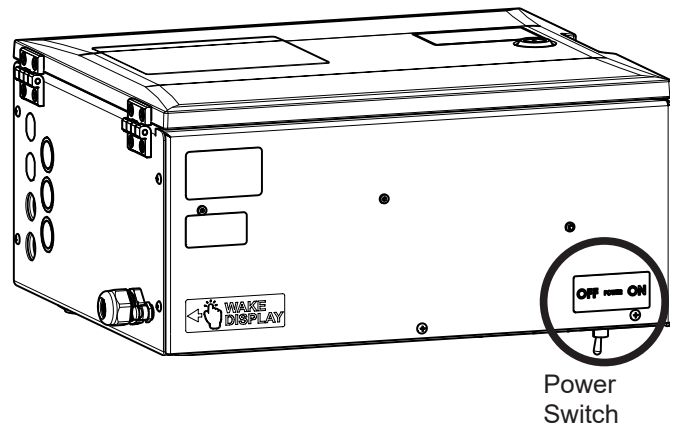

Figure 2. Set Power Switch to OFF

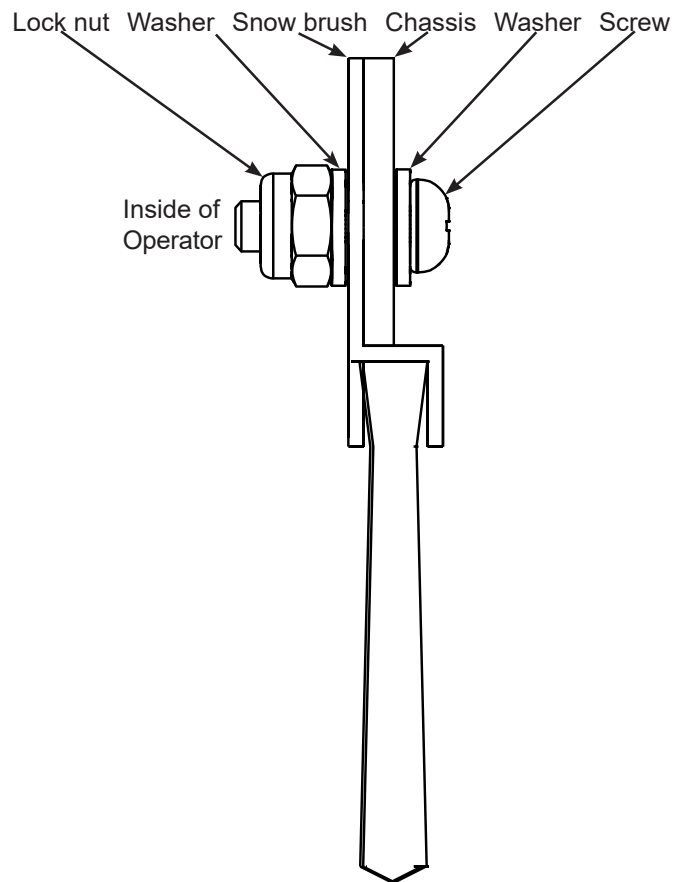

Figure 3. Fasten Snow Brushes

# APPENDIX B - ACCESSORY INSTRUCTIONS

## SNOW KIT INSTRUCTIONS

### INSTALL THE SNOW SCRAPERS

1. Follow steps 1 through 3 of Install the Snow Brushes.
2. Take note of the orientation of the right and left snow scrapers. Slide the brackets into place and adjust them so the scraper rests about  $\frac{1}{8}$  in above the drive rail. Secure the bracket using the fasteners provided (Figure 4 and Figure 6).
3. Install the snow scraper blades on top of the snow scraper brackets with the self-tapping screws (Figure 5).
4. Follow steps 4 through 6 of Install the Snow Brushes.

Screw Washer Snow Scraper Chassis Washer Lock nut

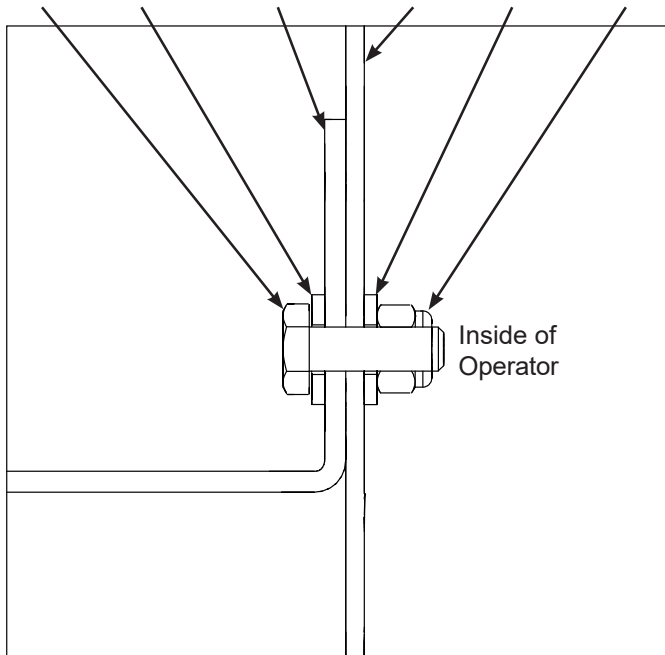

Figure 4. Snow Scraper Bracket Fasteners

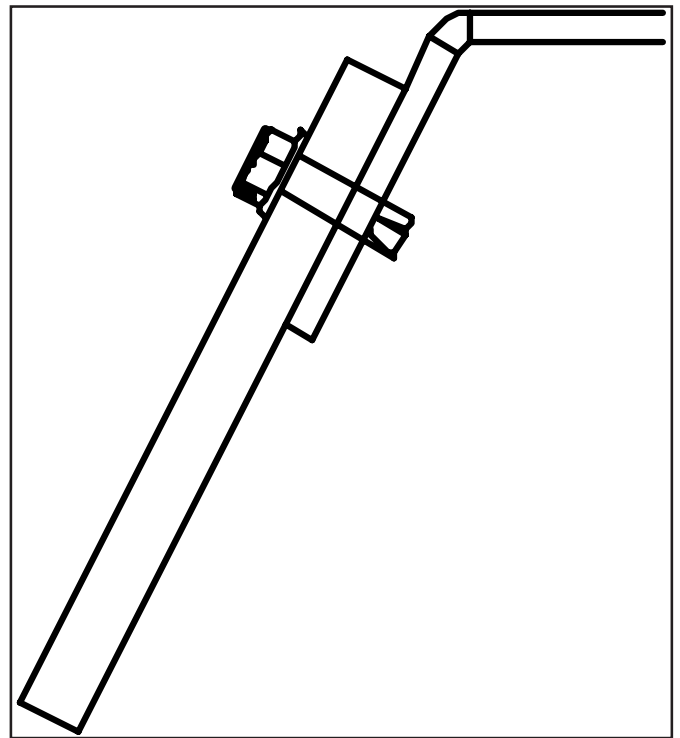

Figure 5. Snow Scraper Self-Tapping Screw

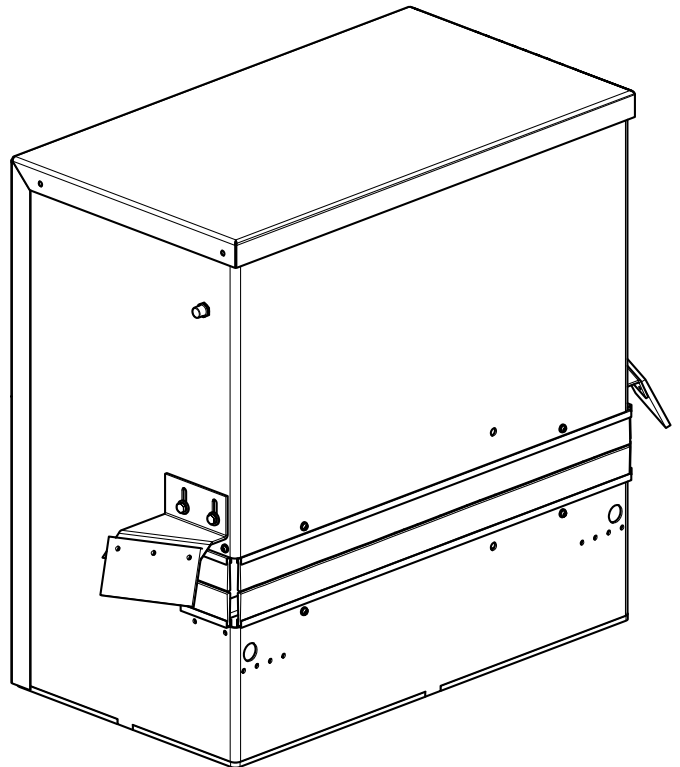

Figure 6. Complete Snow Brush and Scraper Installation

## XTREMEDRIVE INSTRUCTIONS

### PARTS

- XtremeDrive wheel
- XtremeDrive rack
- All thread rod 6.5 in (165 mm)

### HARDWARE

- ¼-20 x 5/8 in flat head screw
- ¼-20 attachment nut

### (OPTIONAL) INSTALLATION KIT MX002750

- Transfer punch
- Drill jig
- Countersink drill bit

### TOOLS

- Hacksaw
- Cordless drill
- ¼ in drill bit
- Phillips-head screwdriver
- Hammer
- Channel locks
- Permanent marker
- Blue Loctite

### SITE PLANNING AND INSTALLATION TIPS

- At retrofit sites, the rack can be installed on the flanged drive rail or the standard grooved drive rail.
- The rack is 0.4 in (10 mm) thick and mounts beneath the drive rail. You will need to raise the drive rail 0.25 to 0.5 in (6 to 13 mm) along the gate uprights and the entire drive rail path, especially if the operator has 8 in (200 mm) wheels.
- Replace the bottom drive wheel with the XtremeDrive wheel. The XtremeDrive wheel is not used along the top surface of drive rail.
- Dual limit sensor - check dual limit sensor position and make any necessary adjustments.
- Limit flag spacers - optional spacers available to increase clearance between limit sensors and XtremeDrive rack.

### NOTICE

The drive rail must not sag in the center or it will rub against dual limit sensors.

### CAUTION

Turn off power to the gate operator and take the necessary precautions to avoid electrical shock.

## INSTALL THE XTREMEDRIVE SYSTEM

### PREPARATION

1. Remove the cover.
2. Set the power switch to OFF.
3. Unclamp the drive wheels.

### NOTICE

Ensure proper XtremeDrive rack alignment throughout the installation process. Improper alignment could require drive rail replacement or cause poor XtremeDrive performance.

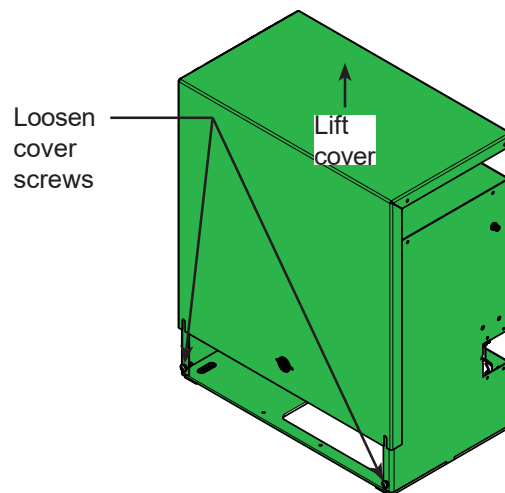

Figure 1. Remove the Cover

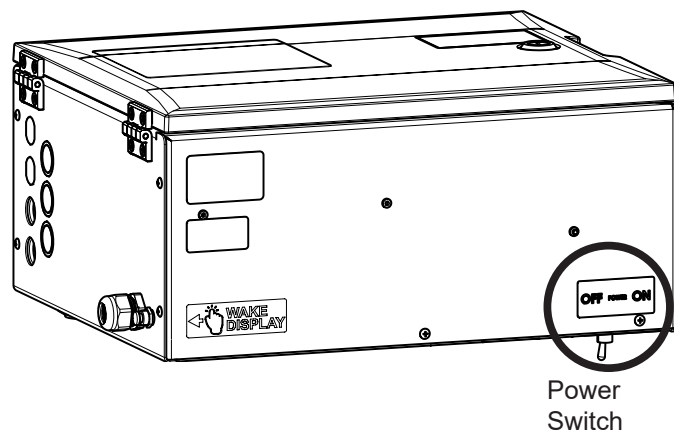

Figure 2. Set Power Switch to OFF

# APPENDIX B - ACCESSORY INSTRUCTIONS

## XTREMEDRIVE INSTRUCTIONS

### MARK, DRILL, AND COUNTERSINK MOUNTING HOLES

Note: Mark holes for one section of drive rack at a time.

4. Mark the mounting holes.

#### To use a piece of XtremeDrive rack:

- a. On top of the drive rail, align the XtremeDrive rack  $\frac{3}{8}$  in (10 mm) from the end of the drive rail (in the open/close direction) and aligned with the edge of the flat of the drive rail toward the operator.
- b. Gently clamp the XtremeDrive rack in place and mark the hole centers.
- c. Remove the XtremeDrive rack
- d. Drill the marked hole locations with a  $\frac{1}{4}$  in drill bit.

#### To use optional Installation Kit (MX002750):

- a. On top of the drive rail, align the drill jig 1 in (25 mm) from one end of the drive rail (in the open/close direction) with the pins against the edge of the drive rail on the drive track side.
  - b. Clamp the drill jig onto the rail and use the center/transfer punch to mark the hole centers.
  - c. Drill the marked hole locations with a  $\frac{1}{4}$  in drill bit.
  - d. Remove the drill jig.
5. Countersink each hole. Make sure the countersink is deep enough for the screw heads to be flush with the drive rail.

Note: Installation Kit (MX002750) includes the appropriate countersink bit.

### INSTALL THE XTREMEDRIVE RACK

6. Align the first piece of XtremeDrive rack to the first set of mounting holes with the rack under the drive rail and the rack teeth pointing down.

#### NOTICE

Make sure that the XtremeDrive rack does not crash into the dual limit sensor.

7. Clamp the XtremeDrive rack in position.
8. Add a drop of blue thread locker to each screw before tightening the screw, rail, XtremeDrive rack, and nut.
9. Install the first two screws and tighten with a Phillips-head screwdriver.
10. When necessary, leave the third mounting hole open and use a shoulder bolt to align the next set of XtremeDrive rack mounting holes.

11. Repeat steps 4 through 10 to install XtremeDrive rack across the drive rail.
12. At the end of the drive rail, make sure the last mounting hole is fastened and flush cut any XtremeDrive rack overhang to the drive rail.

### INSTALL THE XTREMEDRIVE WHEEL

13. Remove the pivot arms.
14. Remove the AdvanceDrive wheel from the lower pivot arm.
15. Install the XtremeDrive wheel.

### COMPLETE XTREMEDRIVE SYSTEM INSTALLATION

16. Install the pivot arms.
17. Clamp the drive wheels.
18. If necessary, replace the all thread rod with the 6.5 in (165 mm) piece included in the XtremeDrive kit.
19. Adjust the compression spring to 2 in (50 mm).
20. Set the power switch to ON.
21. Test cycle the gate operator.
22. Install the cover.

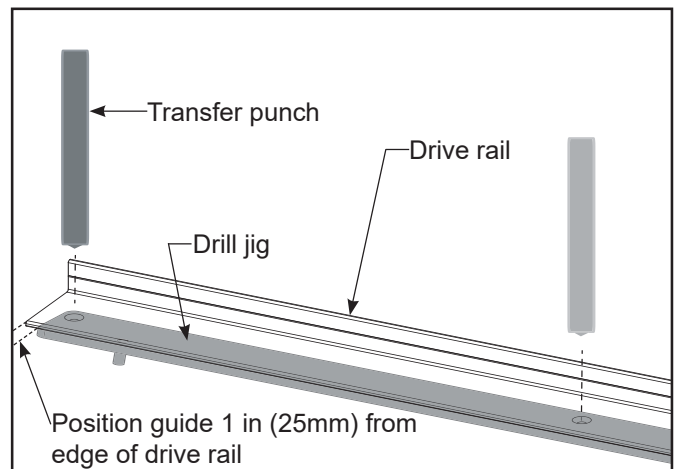

Figure 3. Mark the Mounting Holes

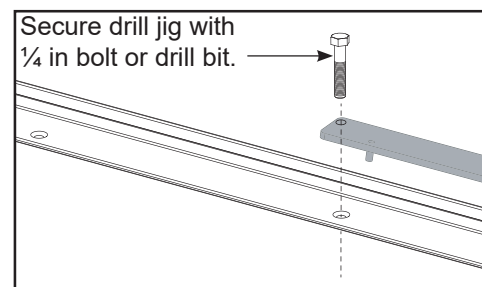

Figure 4. Align the Next Set of Mounting Holes

## XTREMEDRIVE INSTRUCTIONS

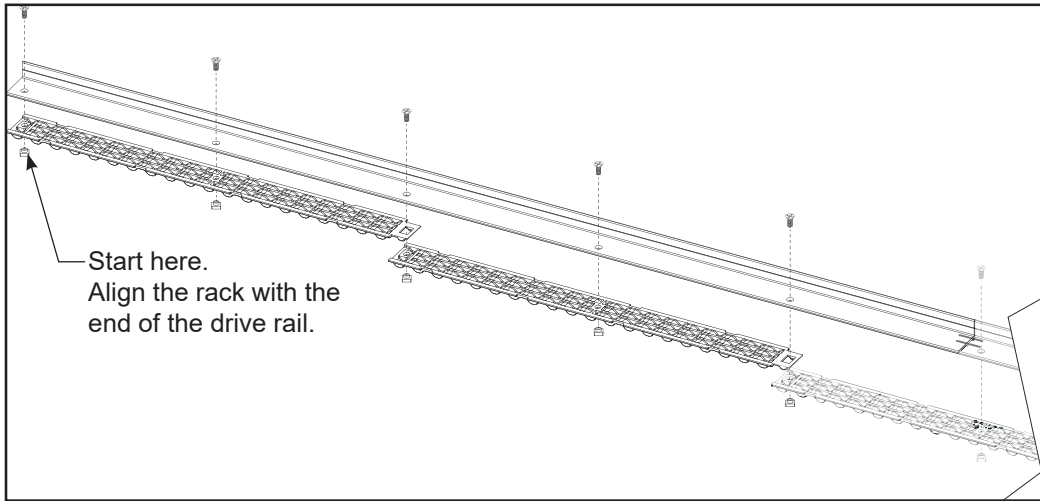

Figure 5. Mount the XtremeDrive Rack

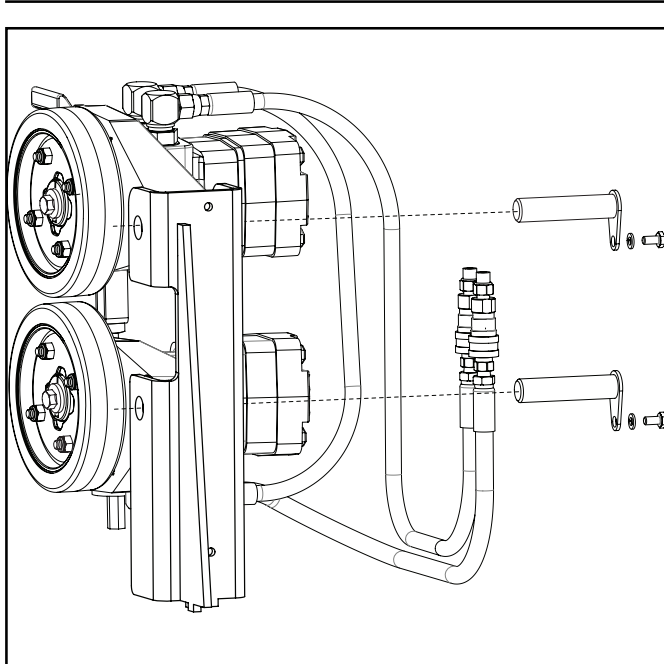

Figure 6. Pivot Arm Mounting Bolts

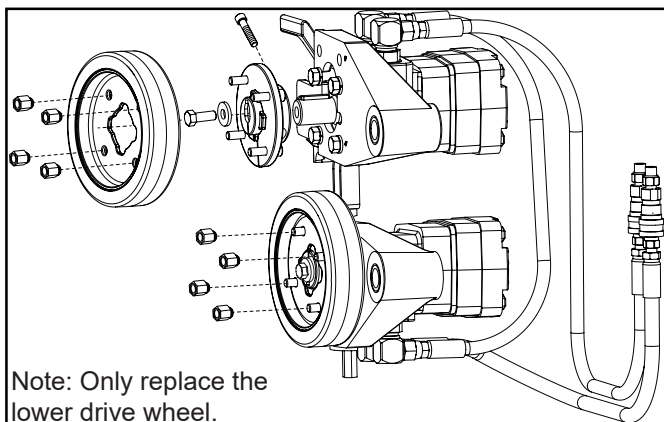

Figure 7. Mount the Drive Wheels

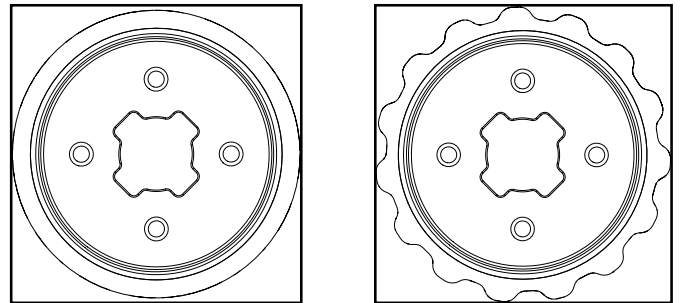

Figure 8. AdvanCdDrive and XtremeDrive Wheels

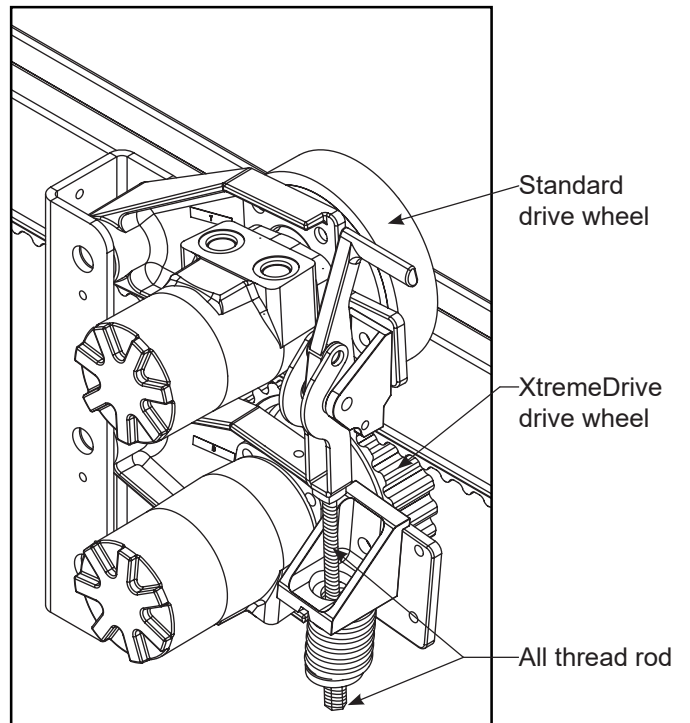

Figure 9. Assembled XtremeDrive System



# APPENDIX B - ACCESSORY INSTRUCTIONS

## HEATER INSTRUCTIONS

The following instructions are intended to assist the user in the installation of the heater unit for use on the SlideDriver II gate operators. The heater prevents components from freezing and not operating properly. Please read all assembly instructions before installing the kit.

### PARTS

- Heater strip
- Heater cord
- Romex connector
- Thermal switch
- Heater contactor

### HARDWARE

- 1/4-20 x 1 in bolt
- 1/4 in washers
- 7/16 in nuts
- 8-32 x 1/2 in self-tapping screw

### TOOLS

- Standard wrenches
- #29 drill bit (0.136 in)

### PREPARATION

1. Remove cover.
2. Set the power switch to OFF.
3. Remove the SmartTouch Controller.
4. Drill a #29 (0.136 in) hole in the back of the electrical enclosure (Figure 3).
5. Install the thermal switch in the hole and fasten with two 8-32 x 1/2 in self-tapping screws (Figure 4).

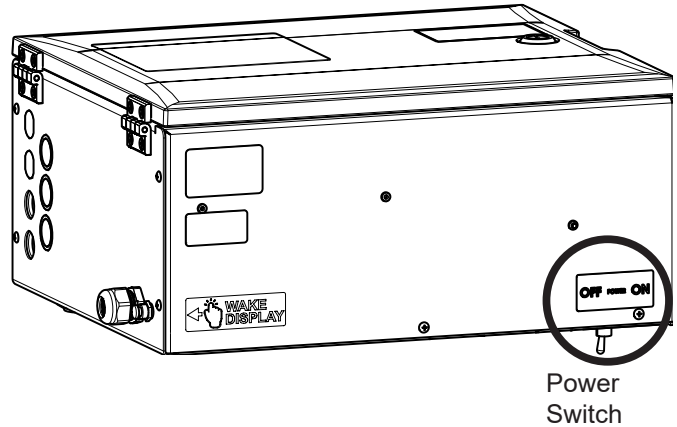
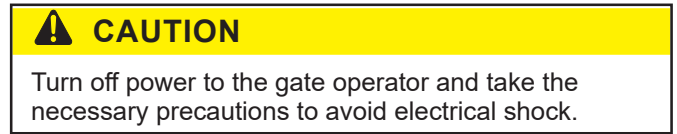

Figure 2. Set Power Switch to OFF

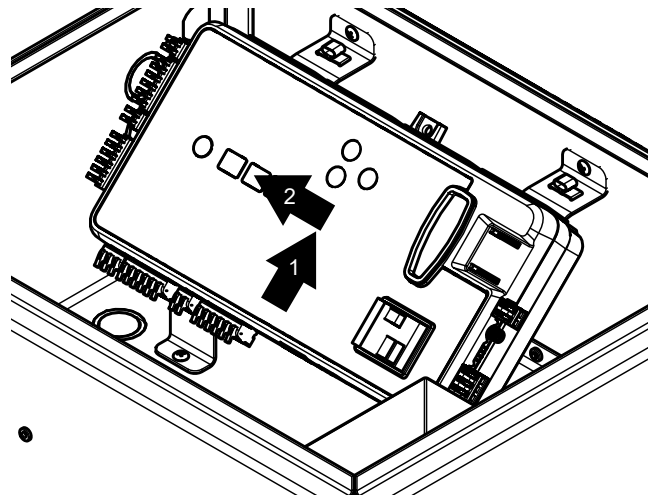

Figure 3. Remove SmartTouch Controller

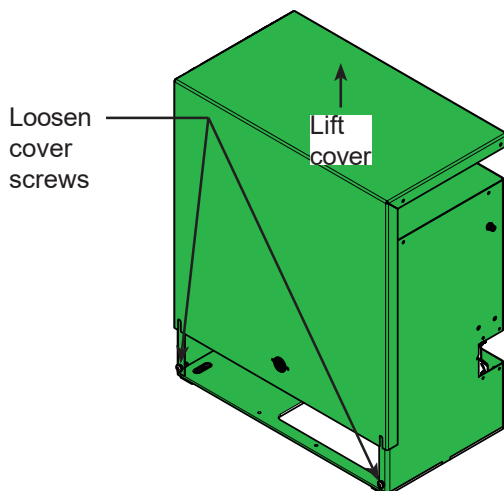

Figure 1. Remove the Cover

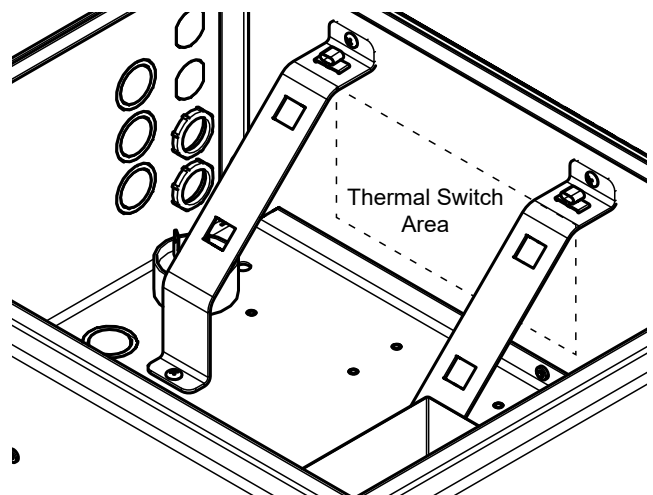

Figure 4. Install Thermal Switch



## HEATER INSTRUCTIONS

### INSTALL THE HEATER

6. Remove the two  $\frac{1}{4}$  in bolts attached to the pin tabs.
7. Remove the pins. Lift the pivot arms to make the pins easier to remove (Figure 5).

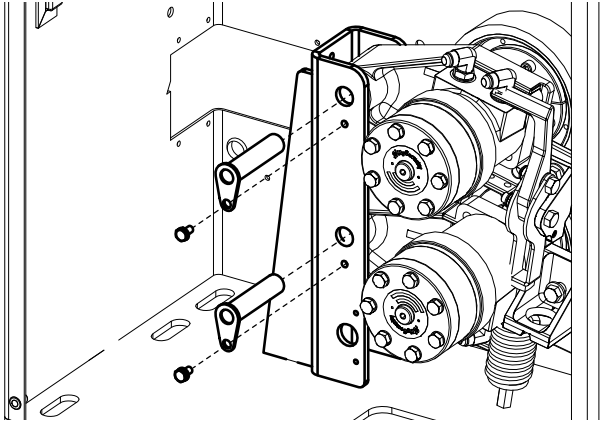

Figure 5. Remove Pivot Arm Pins

8. Slide the two pivot arms and motors out as a complete unit (Figure 6).

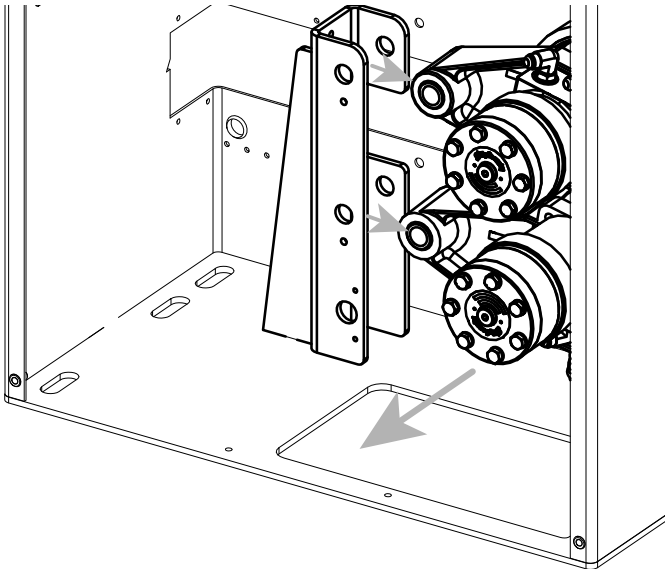

Figure 6. Remove Pivot Arm Assembly

9. Install the heater strip vertically in the drive post with the terminals down and facing out with the  $\frac{1}{4}$ -20 x 1 in bolts (Figure 7).

Note: Use a flat washer on the outside of the drive post and a flat washer on the inside of the drive post as a stand off keeping the heater strip from contacting the paint of the drive post. Complete the mounting by adding the  $\frac{7}{16}$  in nuts.

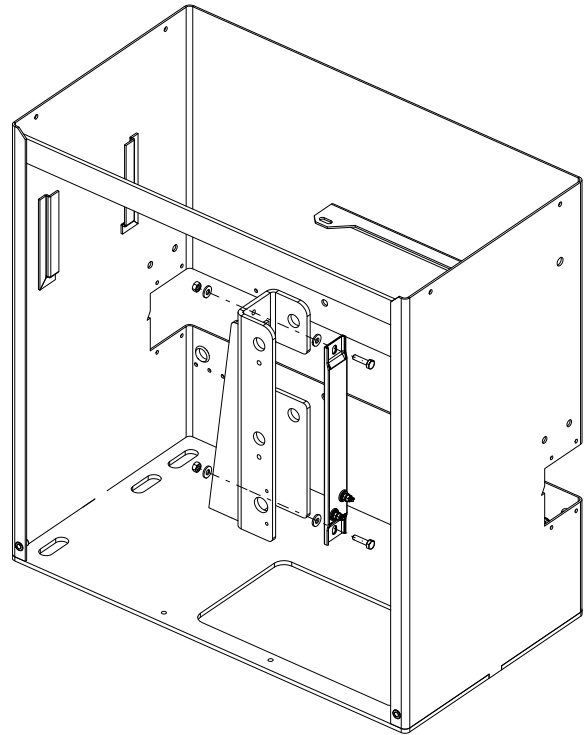

Figure 7. Install Heater Strip

### HEATER WIRING (FIGURE 8 AND FIGURE 9)

10. Connect the heater cord to the heater strip; be sure to bend the terminals up so that they contact no metal surfaces.
11. Take the lock washer off of the included romex connector and run the lock washer onto the heater cord.
12. Then take the heater cord and run it through the hole in the bottom of the drive post.
13. Slip the rest of the romex connector onto the cord then run it down to the hole and mount the lock washer.
14. Take the romex connector and tighten it down onto the heater cord.
15. Take the heater cord up to the electrical box and run it through one of the knockouts. Use the plastic cord connectors to attach to the panel wall.
16. Install the heater contactor in the electrical box and connect the heater contactor to the power supply or motor contactor: L1 to L1 and L2 to L2.
17. Connect one lead of the heater cord to terminal T1 of the heater contactor and connect the other to T2.
18. Install thermal switch to power supply -V and heater contactor A2.
19. Connect power supply V+ to heater contactor A1.

# APPENDIX B - ACCESSORY INSTRUCTIONS

## HEATER INSTRUCTIONS

### FINISH INSTALLATION

20. Clean any debris from drilling the thermal switch hole.
21. Install the SmartTouch controller on the mounting brackets and reconnect any disconnected wires.
22. Reinstall the pivot arms and pins.
23. Set the power switch to ON and test cycle the gate.
24. Close the electrical box and install the cover.

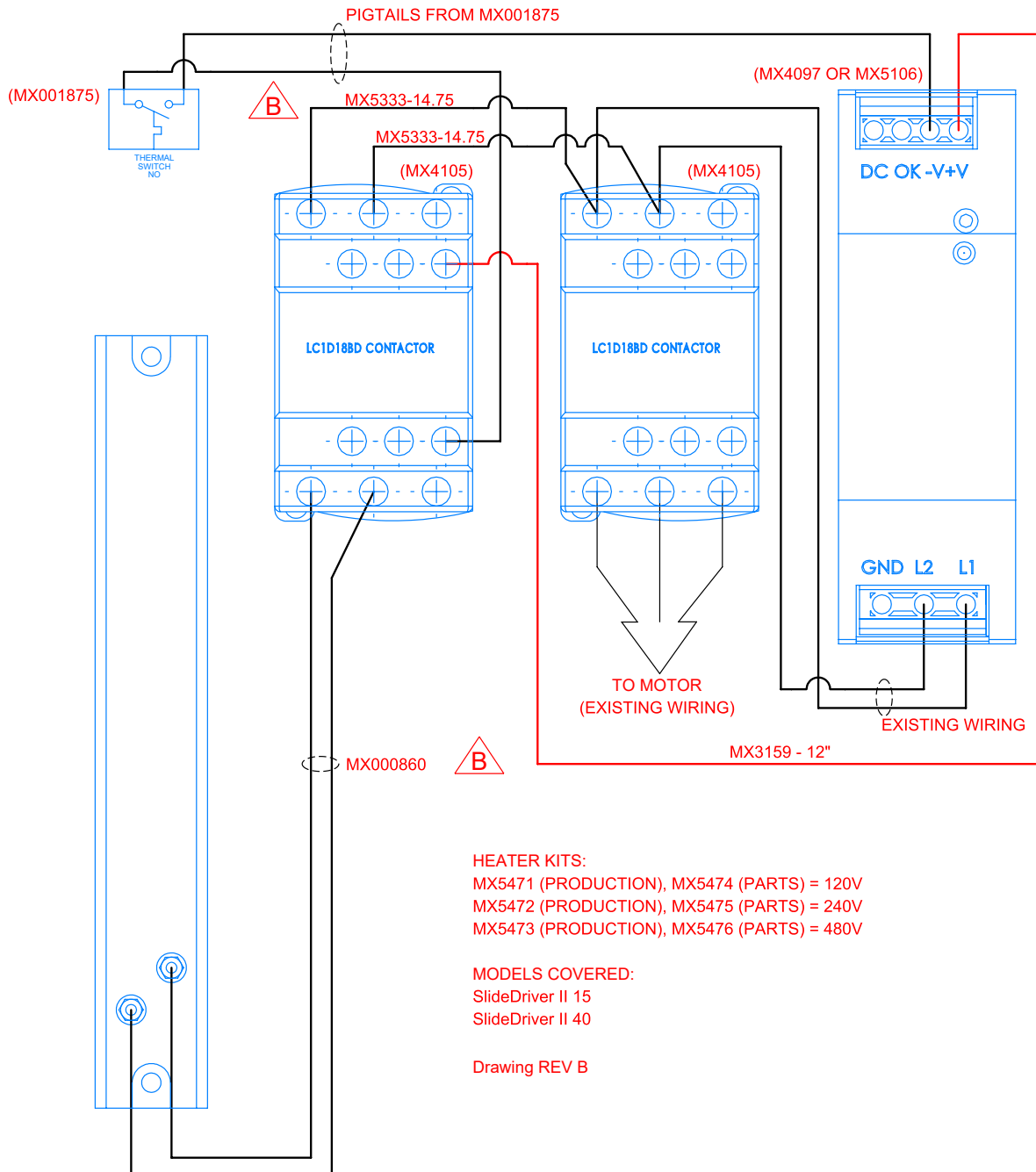

Figure 8. Heater Strip Wiring, non-VFD

## HEATER INSTRUCTIONS

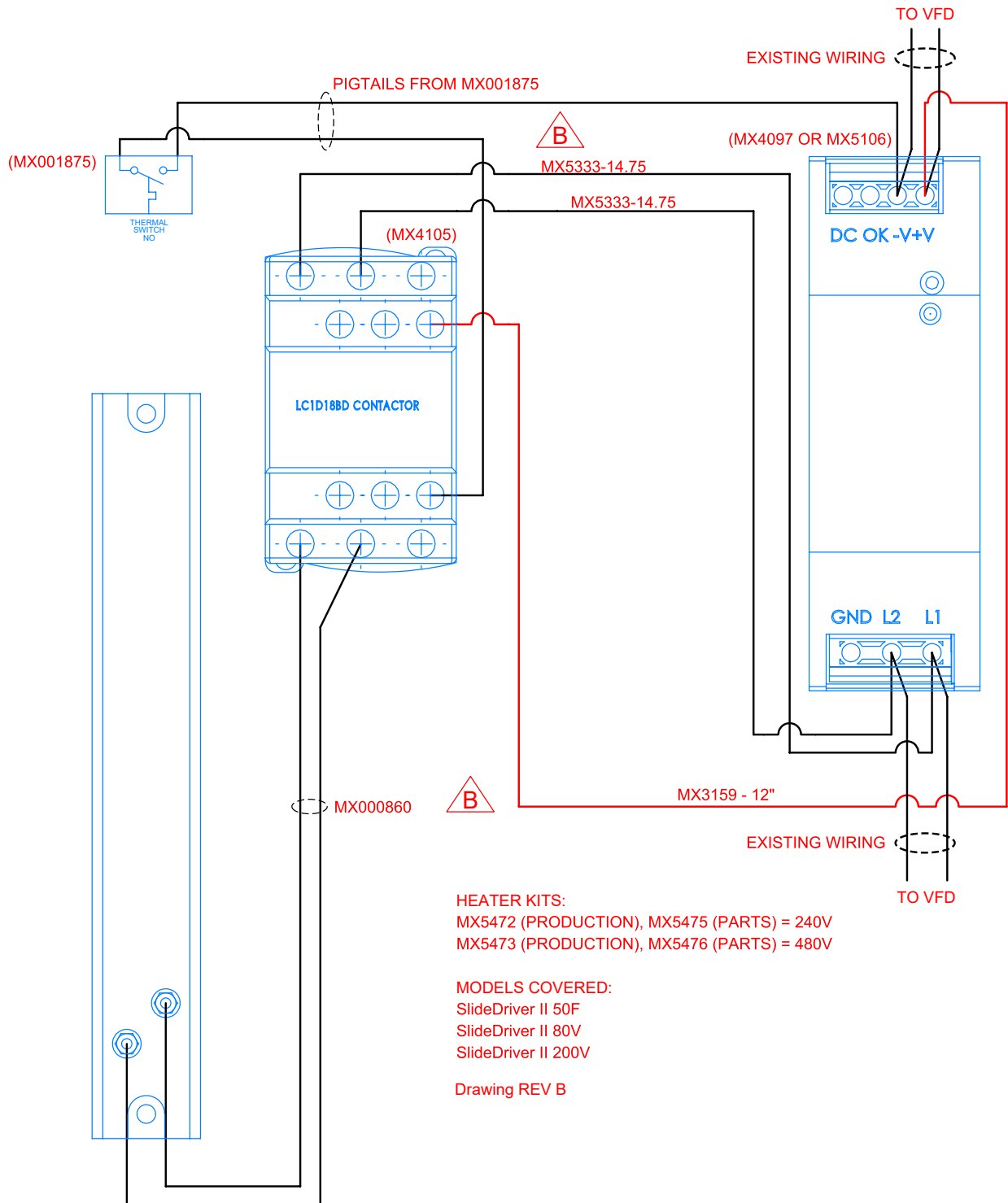

Figure 9. Heater Strip Wiring, VFD

# APPENDIX B - ACCESSORY INSTRUCTIONS

## SOLENOID LOCK INSTRUCTIONS

HySecurity offers an optional internal solenoid-operated dead-bolt lock that employs a  $\frac{3}{4}$  in (19 mm) stainless-steel lock pin that fits into a notch cut into the flanged drive rail. The solenoid lock is voltage specific; either 120VAC or 208-240VAC. If the gate operator voltage is modified, make sure the solenoid lock is also changed. An internal indicator switch, which may be required in some installations, verifies whether the bolt is in the locked or unlocked position.

Note: The standard grooved drive rail does not accommodate the solenoid lock mechanism. If you plan to use a solenoid lock, be sure to order the appropriate flanged drive rail.

### PARTS

- Solenoid lock (voltage specific)
- Solenoid contactor

### HARDWARE

- $\frac{5}{16}$ -18 x  $\frac{3}{4}$  in HHCS
- $\frac{3}{8}$  in lock washer
- $\frac{3}{8}$  in washer

### TOOLS

- Permanent marker
- Hacksaw
- $\frac{1}{2}$  in open-end wrench

### PREPARE THE OPERATOR

1. Remove the cover.
2. Set the power switch to OFF.

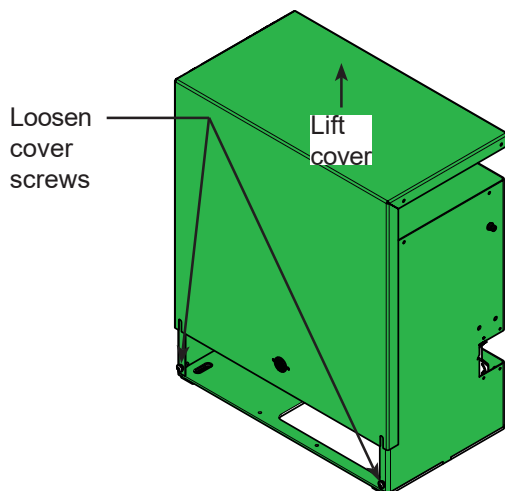

Figure 1. Remove the Cover

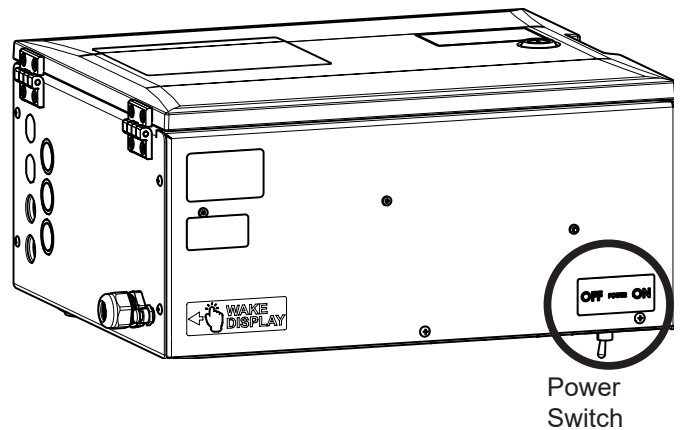

Figure 2. Set Power Switch to OFF

### SOLENOID LOCK INSTALLATION AND ADJUSTMENT

The solenoid lock housing may need to be adjusted; the face of the solenoid lock housing is slotted to accommodate this adjustment. To adjust the solenoid lock height:

3. Install the solenoid lock using the included hardware and a  $\frac{1}{2}$  in open-end wrench, but do not tighten all the way (Figure 3).
4. Move the housing up or down so that the dead-bolt aligns with the center of the vertical edge of the drive rail.
5. Tighten the bolts.

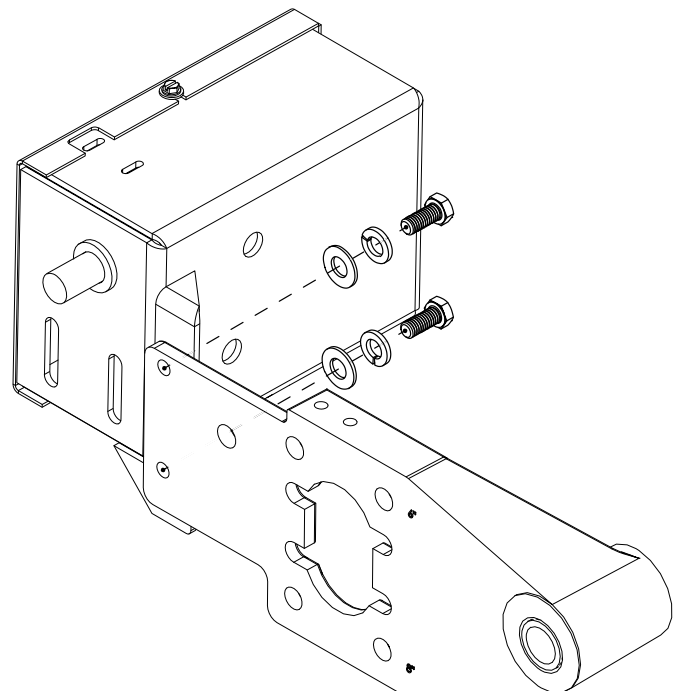

Figure 3. Install Solenoid Lock

## SOLENOID LOCK INSTRUCTIONS

### DRIVE RAIL PREPARATION

See “Flanged Drive Rail and Limit Flags” on page 28 in the SlideDriver II Digital Installation manual for flanged drive rail installation. Operators equipped with our factory solenoid lock require a notch to be cut into the outer vertical face of the flanged drive rail. The notch location is determined in the field after the gate operator is functioning properly. To prepare the flanged drive rail:

6. Run the gate to its fully-closed position and note the location where the dead-bolt strikes the drive rail.
7. Mark a 3 in (76 mm) wide slot in the drive rail with the dead-bolt in the center.
8. Using a hacksaw, make two cuts and then break out the notched section (Figure 4).
9. Operate the gate a few times after programming to verify that the dead-bolt always enters the notched area.

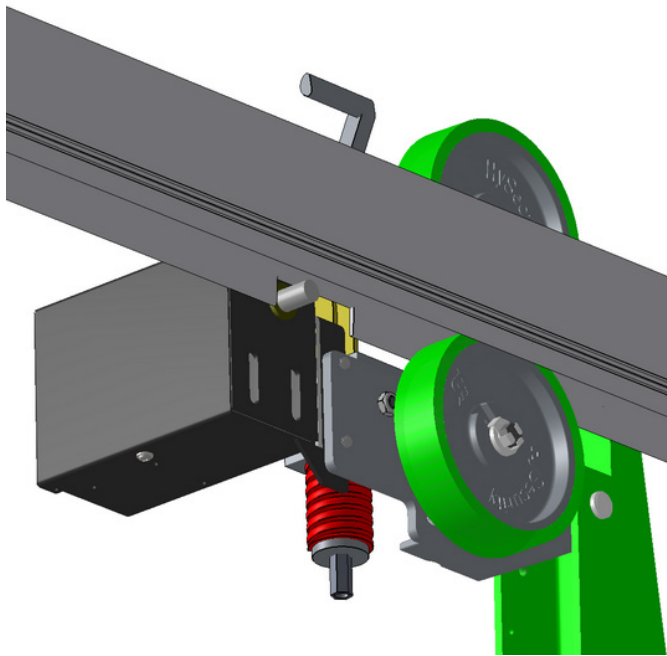

Figure 4. Prepare Drive Rail and Check Alignment

### CONNECT SOLENOID LOCK TO SMARTTOUCH 720/725 CONTROLLER (FIGURE 5 AND FIGURE 6)

10. Install the solenoid contactor
11. Connect the solenoid contactor to the power supply or motor contactor: L1 to L1 and L2 to L2.
12. Connect the red and black solenoid wires to the solenoid contactor NO terminals.
13. Connect solenoid contactor A1 to any open Input or Relay +24V terminal. DO NOT use Sensor +24V terminals.
14. Connect solenoid contactor A2 to NO on Relay 1.
15. Connect COM on Relay 1 to any available Input COM terminal. DO NOT use Sensor COM terminals.

### PROGRAM THE SMARTTOUCH 720/725 CONTROLLER FOR SOLENOID LOCK OPERATION (FIGURE 7)

16. Set the power switch to ON.
17. Press MENU on the SmartTouch 720/725 Controller.
18. Use the UP or DOWN button to navigate to USER RELAY OUTPUTS and press select.
19. Use the UP or DOWN button to navigate to RELAY 1 LOGIC and press SELECT.
20. Use the arrow buttons to navigate to 6 GATE LOCK and press SELECT.
21. Press BACK until gate status display appears.

Note: Relay 1 can handle up to 240VAC for external power source use.

Note: The green, white, and orange solenoid lock wires and the terminal strip are for use with 3rd party devices such as a status indicator.

# APPENDIX B - ACCESSORY INSTRUCTIONS

## SOLENOID LOCK INSTRUCTIONS

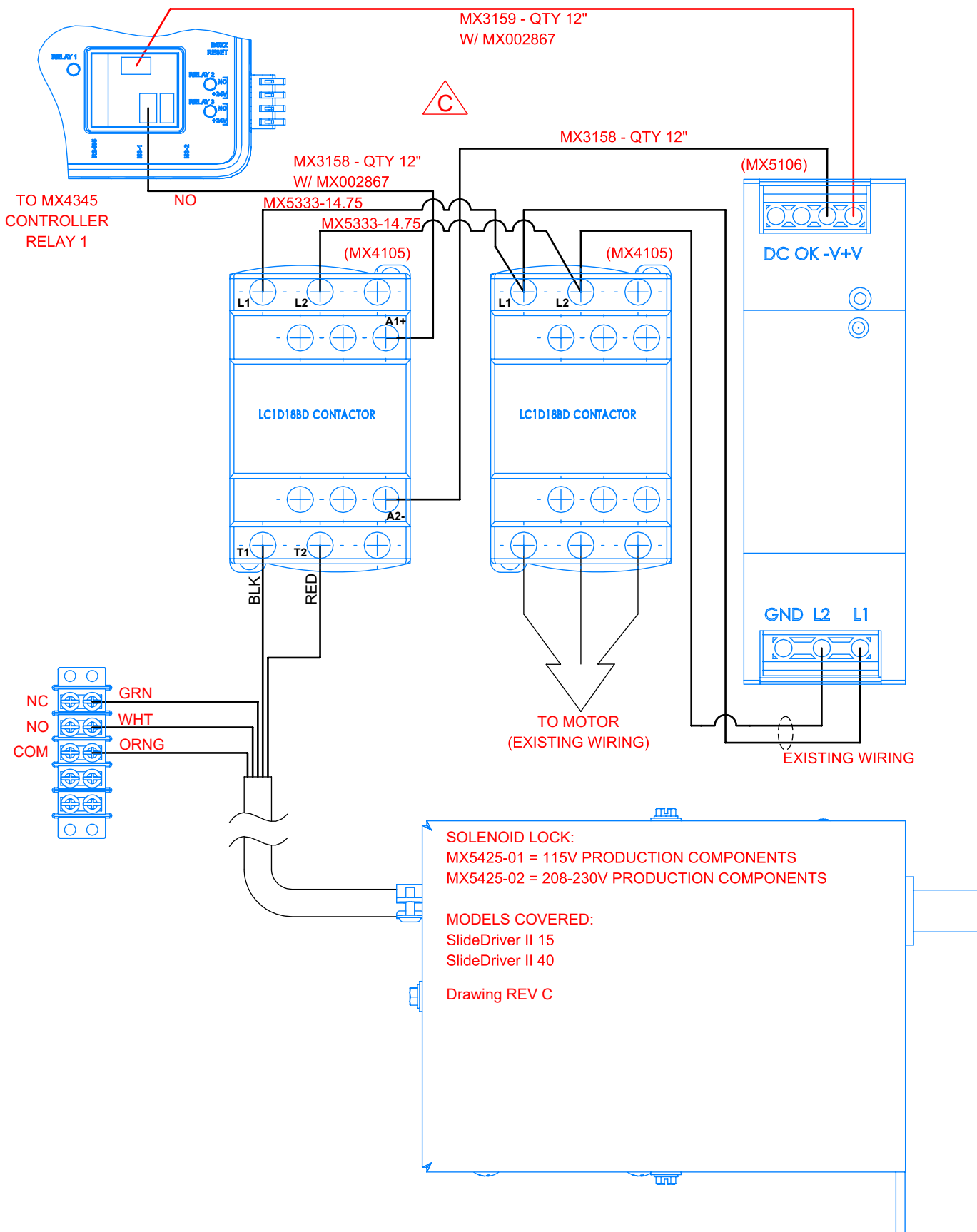

Figure 5. Connect Solenoid Lock to SmartTouch 720/725 Controller, SD15 and SD40

## SOLENOID LOCK INSTRUCTIONS

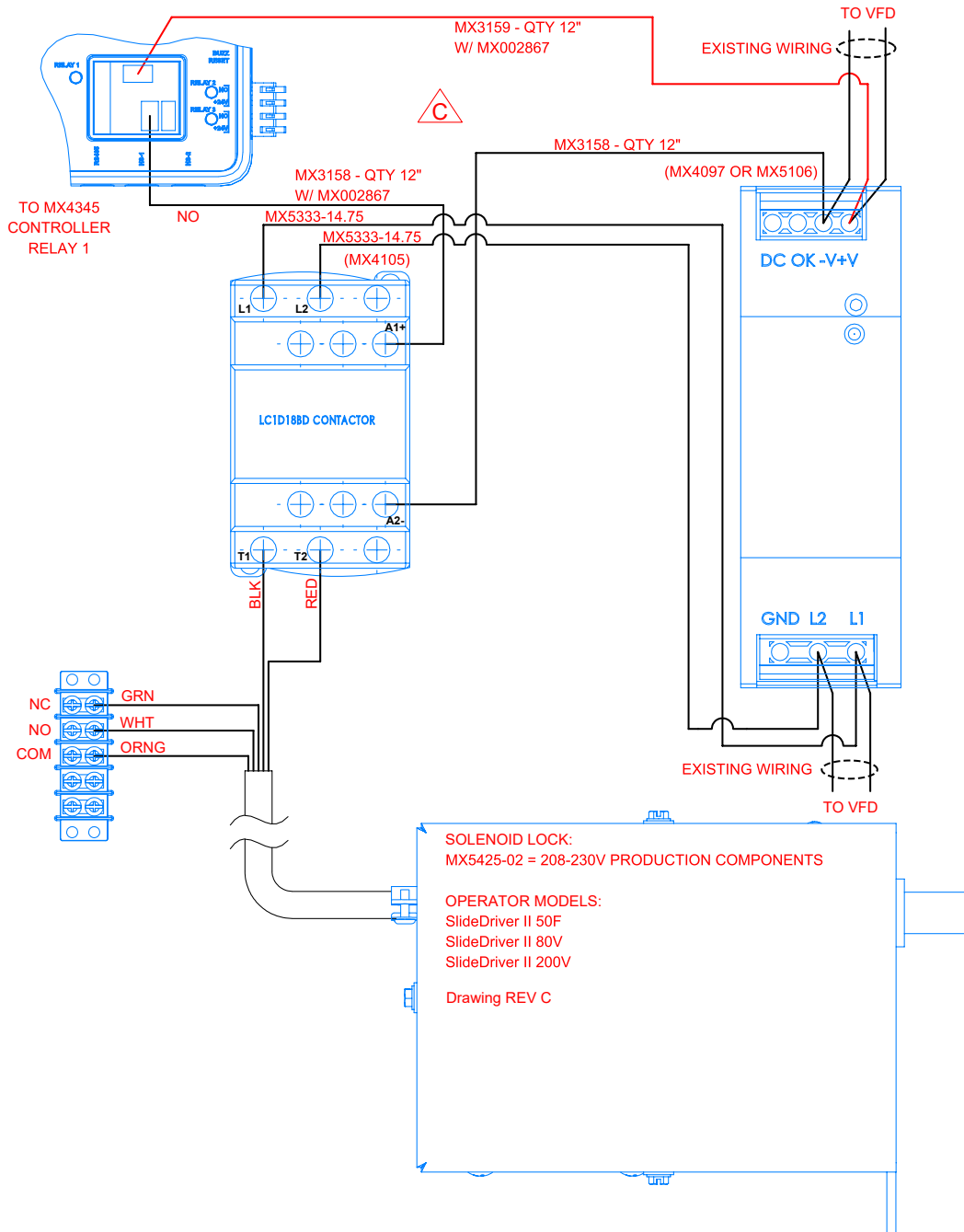

Figure 6. Connect Solenoid Lock to SmartTouch 720/725 Controller, SD50F, SD80V, SD200V

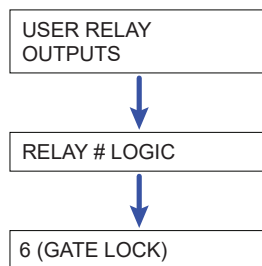

Figure 7. Program SmartTouch 720/725 Controller Relay

# APPENDIX B - ACCESSORY INSTRUCTIONS

## FIRE AND EMERGENCY ACCESS LOCK BOX INSTRUCTIONS

The Fire and Emergency Access Lock Box provides a manual release mechanism for the gate and a microswitch that can be wired to the SmartTouch Controller inside the SlideDriver II gate operator for Fire Department OPEN functionality.

### PARTS

- Fire and emergency access lock box and microswitch
- Drive wheel compression spring
- Handle release assembly
- Pull cable and handle
- Cable jacket
- Cable jacket ferrule (x2)

### HARDWARE

- 1/4-20 x 1/2 in bolt
- 1/4 in washer

### TOOLS REQUIRED

- Phillips-head screwdriver
- Standard hex key set
- Standard socket wrench set
- Standard socket set
- Needle nose pliers with wire cutter

### CAUTION

Turn OFF power to the SlideDriver II and take the necessary precautions to avoid electrical shock.

### INSTALL THE EMERGENCY ACCESS LOCK BOX

1. Remove the cover (Figure 1).

Loosen cover screws

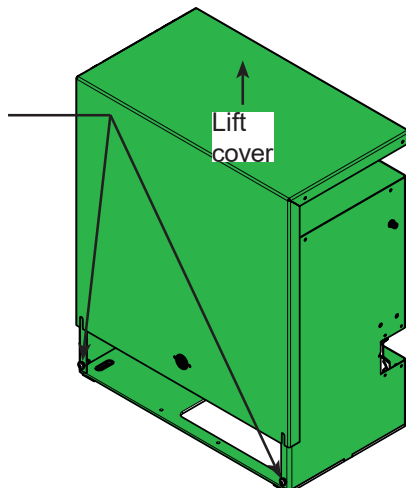

Figure 1. Remove the Cover

2. Open the gate.
3. Set power switch to OFF (Figure 2).

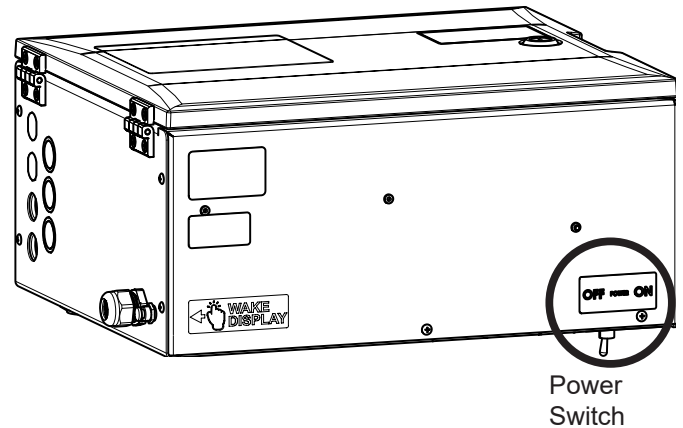

Figure 2. Set Power Switch to OFF

4. Carefully release the drive wheels.
5. Install the drive wheel compression spring (Figure 3).

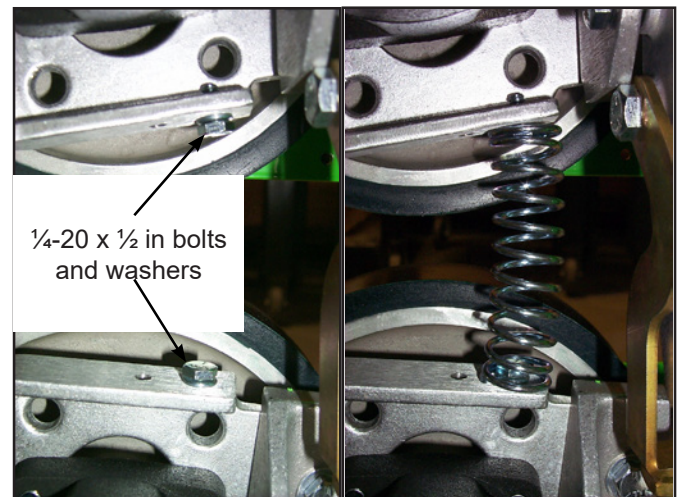

Figure 3. Install Drive Wheel Compression Spring

6. Assemble cable release bracket (Figure 4).
  - a. Install cable clamp and loosely attach nut.
  - b. Assemble cable ferrule and tighten.
  - c. Assemble cable release bracket hinge and ensure that cable release still rotates.
7. Install the cable release bracket (Figure 5).
  - a. Remove the lower toggle handle nut and bolt.
  - b. Put the cable release bracket in place and install the lower toggle handle bolt/nut and the cable release bracket bolt/washer.
  - c. Make sure that the cable release bracket is securely attached.



## FIRE AND EMERGENCY ACCESS LOCK BOX INSTRUCTIONS

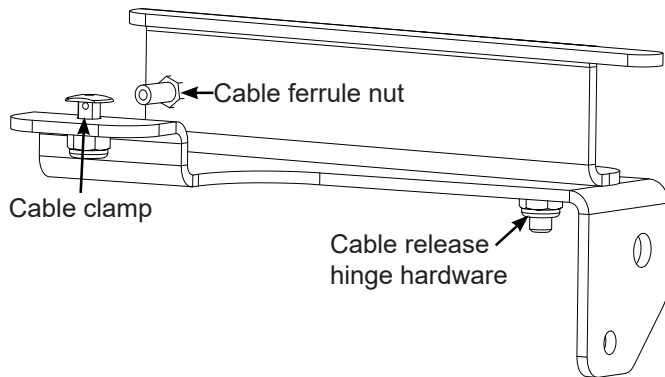

Figure 4. Cable Release Bracket Assembly

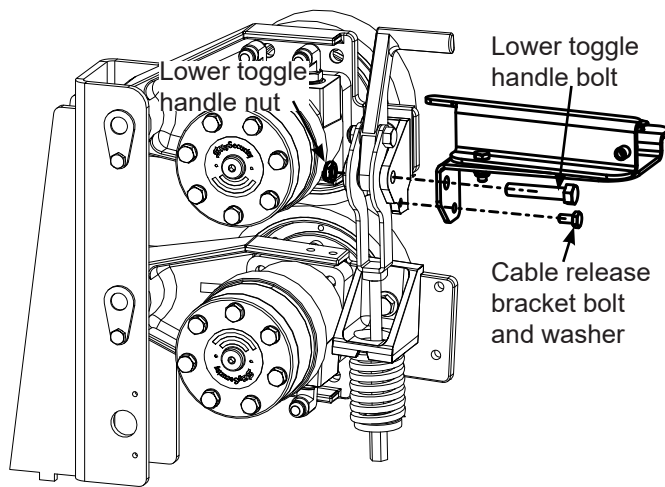

Figure 5. Attach the Cable Release Bracket

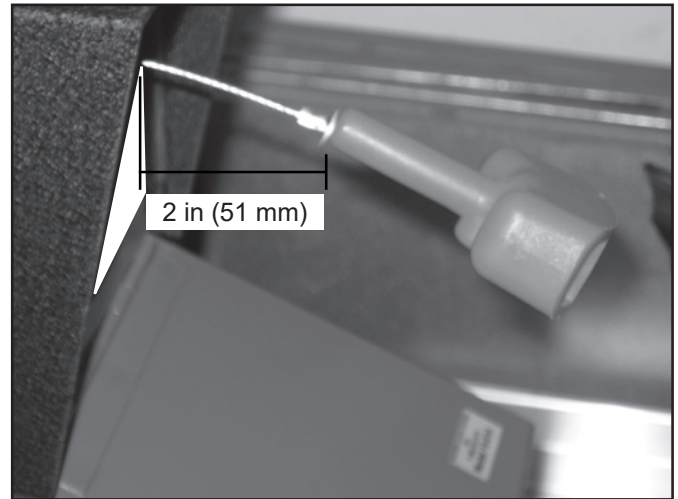

Figure 6. Leave 2 in (51 mm) of Cable Between Pull Handle and Cable Jacket

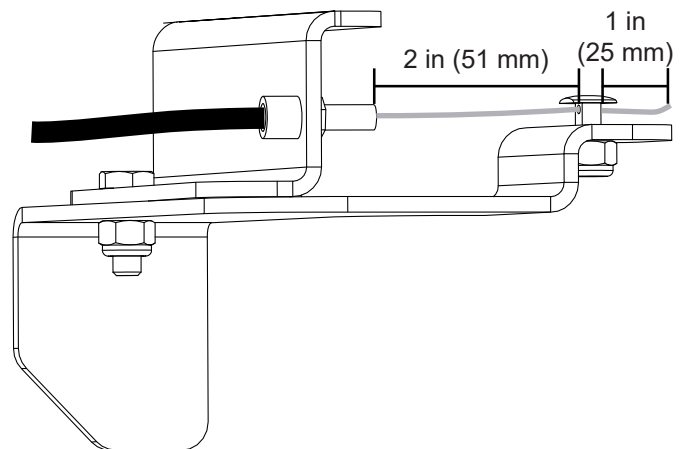

Figure 7. Feed Cable Through Cable Jacket and Clamp

8. Carefully engage the drive wheels.
9. Mount the Fire and Emergency Access Lock Box with the hardware provided, in an appropriate location, and with conduit to the SlideDriver II chassis.
10. Measure and cut cable jacket to length.
11. Feed cable through cable jacket. Stop when the cable reaches the end of the cable jacket.
12. Feed cable and cable jacket through conduit to the cable ferrule in the release bracket.
13. Leave 2 in (51 mm) of cable between the handle and the lock box cable ferrule. Leave 3 in (75 mm) of cable past the cable ferrule in the cable release bracket and cut the excess cable (Figure 6).
14. Route the cable through the cable clamp with 1 inch (25 mm) extending past the clamp (Figure 7).
15. Tighten the cable clamp.

16. Optional: connect microswitch COM and NC (the switch is held down by the lock box door) to SmartTouch Controller Emergency Input (Figure 9) or wire to external access control system.

Note: Emergency Input is set to Fire Department Open by default. See SlideDriver II Digital Installation Manual for additional details.

17. Check red compression spring and adjust to 2 in if necessary.
18. Test the cable release and microswitch (if connected).
19. Reset the toggle handle and return SlideDriver II to normal operation.

# APPENDIX B - ACCESSORY INSTRUCTIONS

## FIRE AND EMERGENCY ACCESS LOCK BOX INSTRUCTIONS

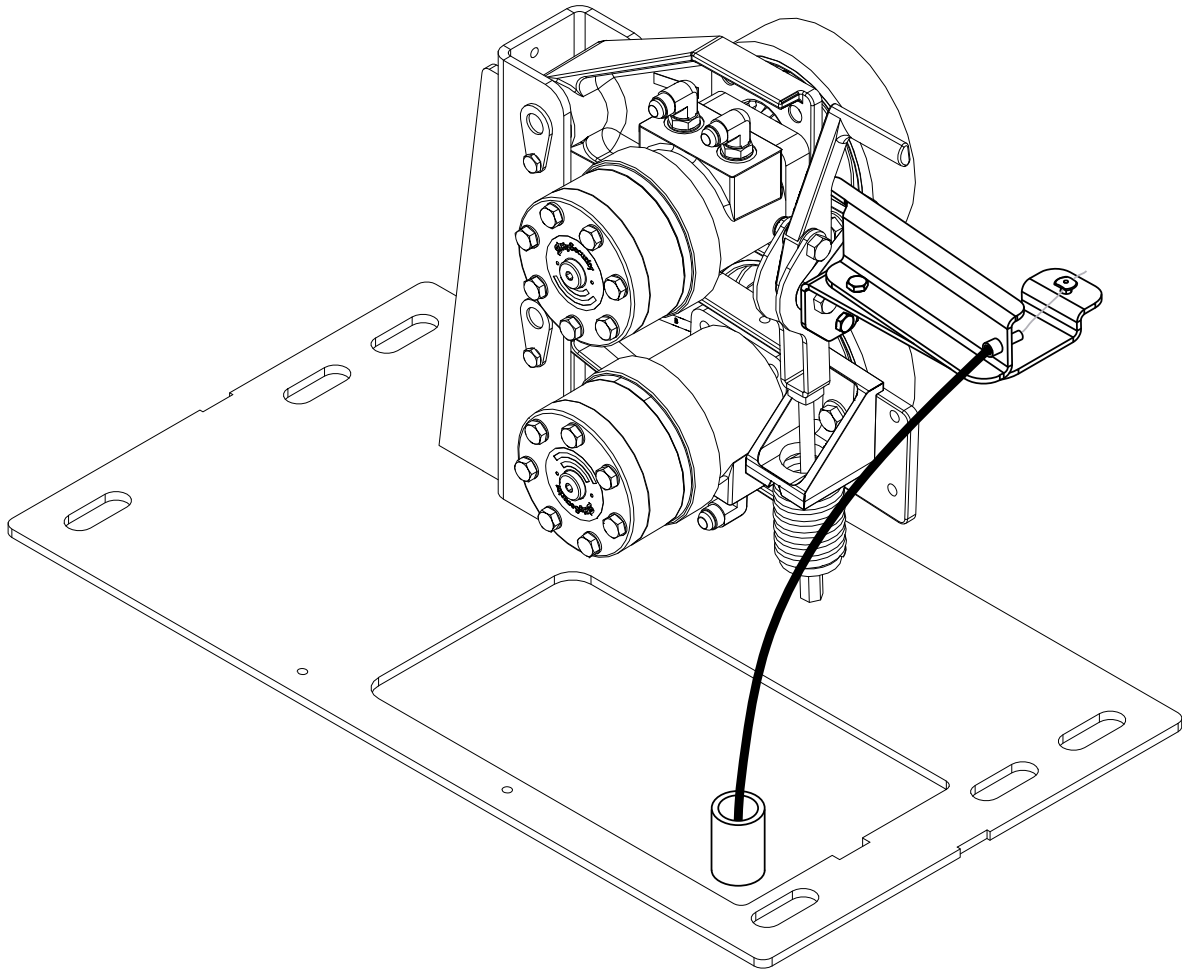

Figure 8. Complete Cable Release Assembly

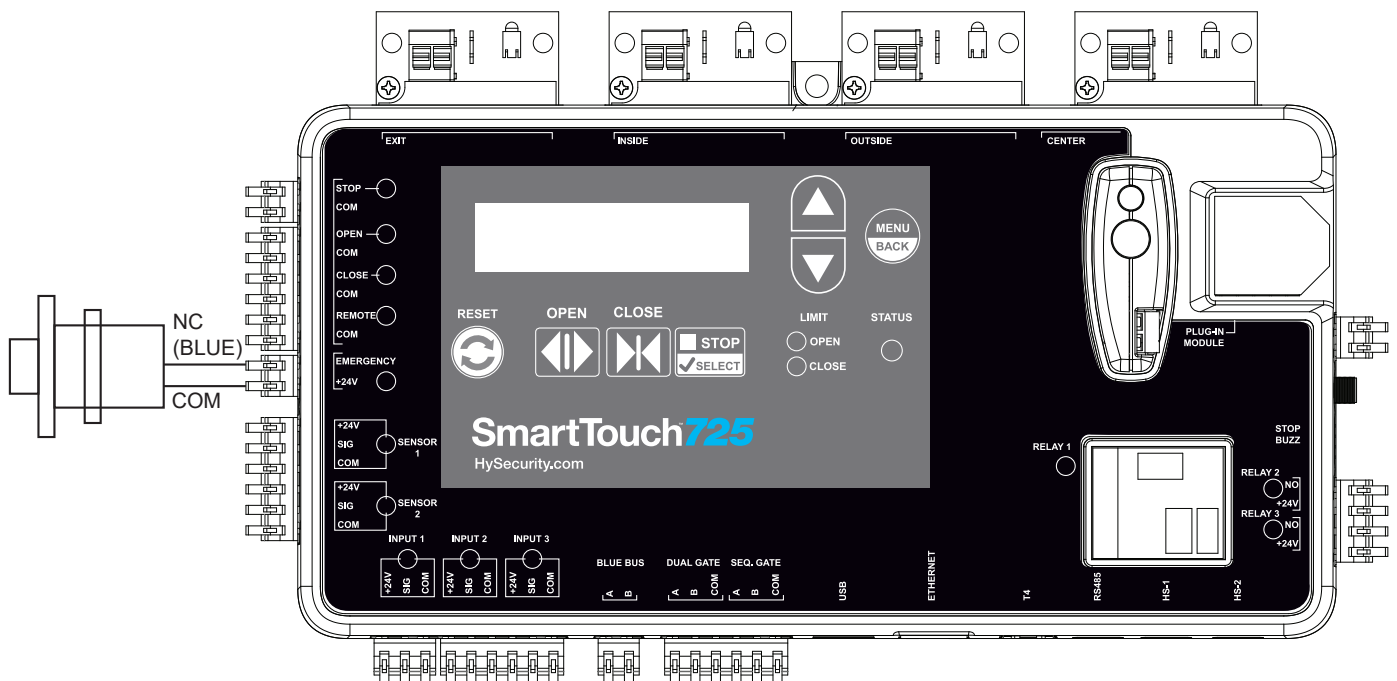
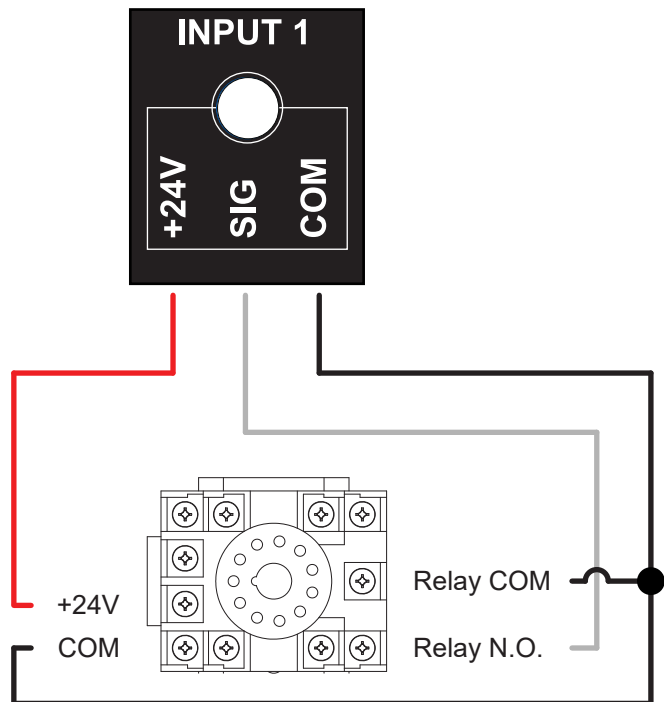

Figure 9. Micro Switch Wiring

## BOX DETECTOR WIRING



Example box detector wiring. Box detectors can connect to any available input on the SmartTouch 720/725 Controller or the I/O Expansion Module.

Remember to program the Input to the appropriate loop setting. See "Programmable Inputs" on page 53.

# APPENDIX C - WIRING DIAGRAMS

## SLIDEDRIVER II 15, 40 1Ø AND 3Ø AC WIRING DIAGRAM

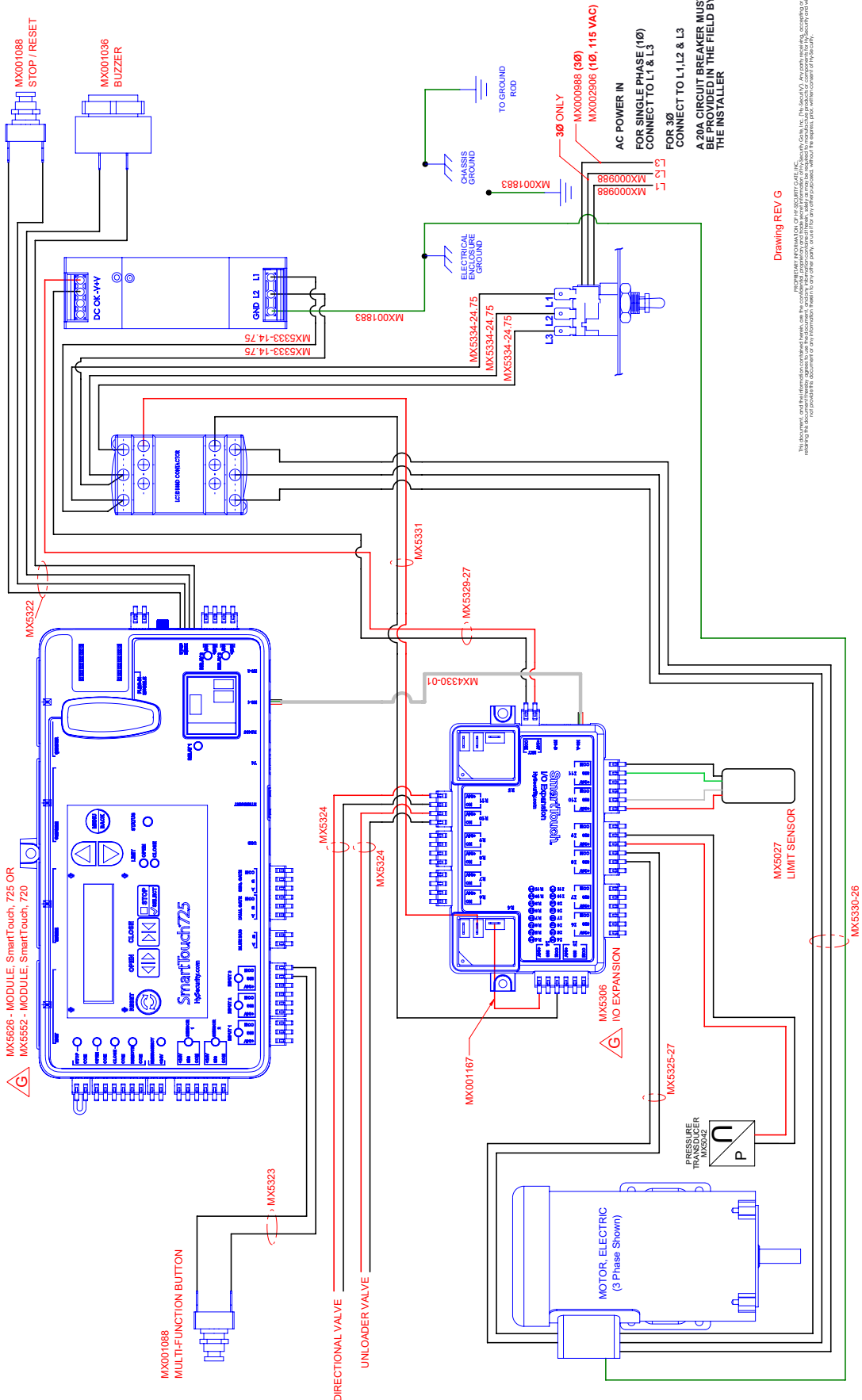

Drawing REV G

This document and the information contained herein are the confidential property of HySecurty, Inc. ("HySecurty"). Any copying, scanning or other use of this document without the express written consent of HySecurty, Inc. is prohibited. HySecurty, Inc. does not warrant the accuracy or completeness of the information contained herein, and it is the user's responsibility to verify the accuracy of the information contained herein. HySecurty, Inc. is not responsible for any damage or loss of data resulting from the use of this document.

## SLIDEDRIVER II 15, 40 DC WIRING DIAGRAM

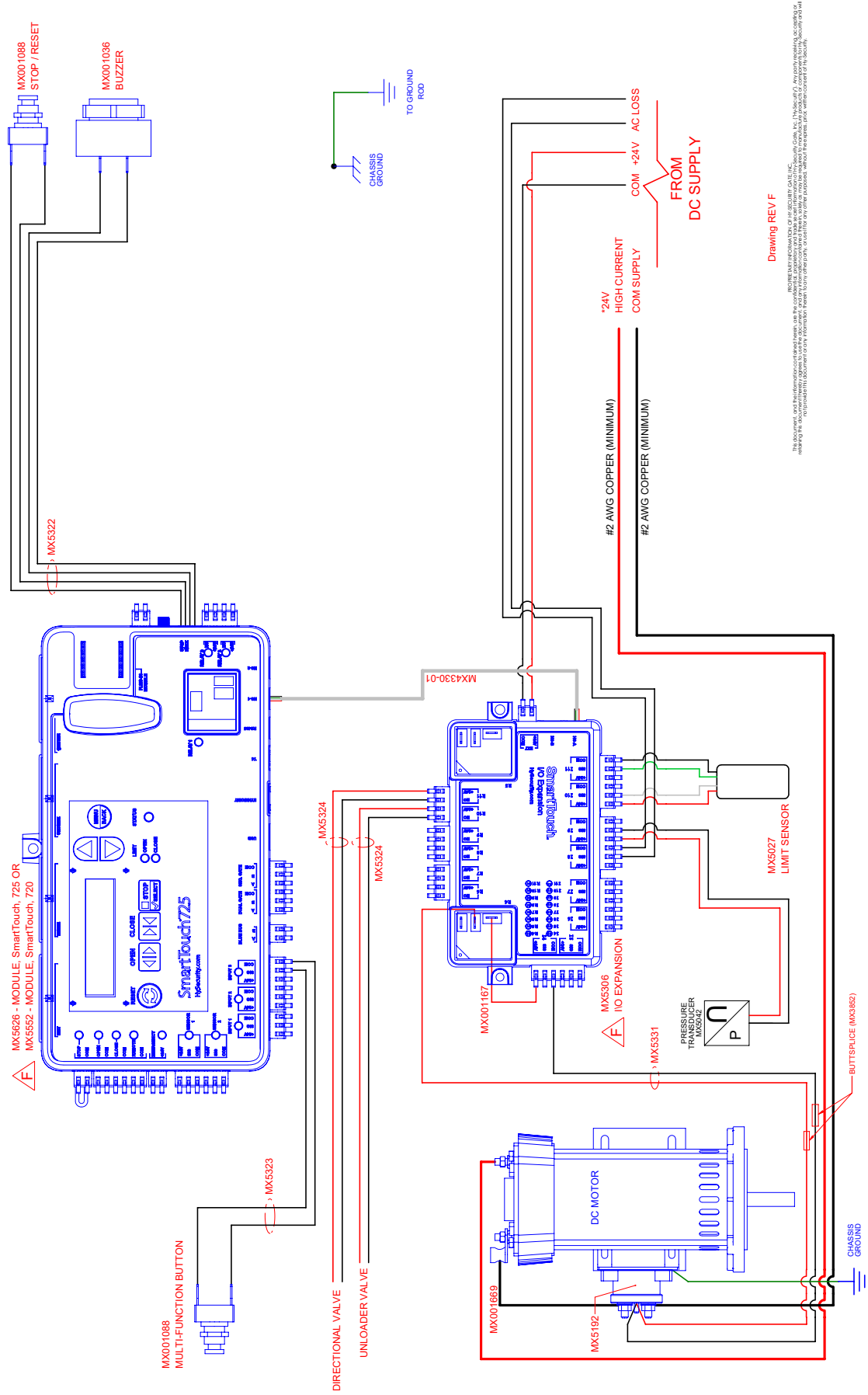

Drawing REV F

This document, and the information contained herein, is the confidential and proprietary information of Ingersoll Rand, Inc. ("Ingersoll Rand"). Any copying, reuse, or distribution of this document, or the information contained herein, without the prior written consent of Ingersoll Rand is prohibited. Ingersoll Rand, Inc. is not responsible for any errors or omissions in this document, and reserves the right to modify the information contained herein without notice.

# APPENDIX C - WIRING DIAGRAMS

## SLIDEDRIVER II 50F 1Ø AC WIRING DIAGRAM

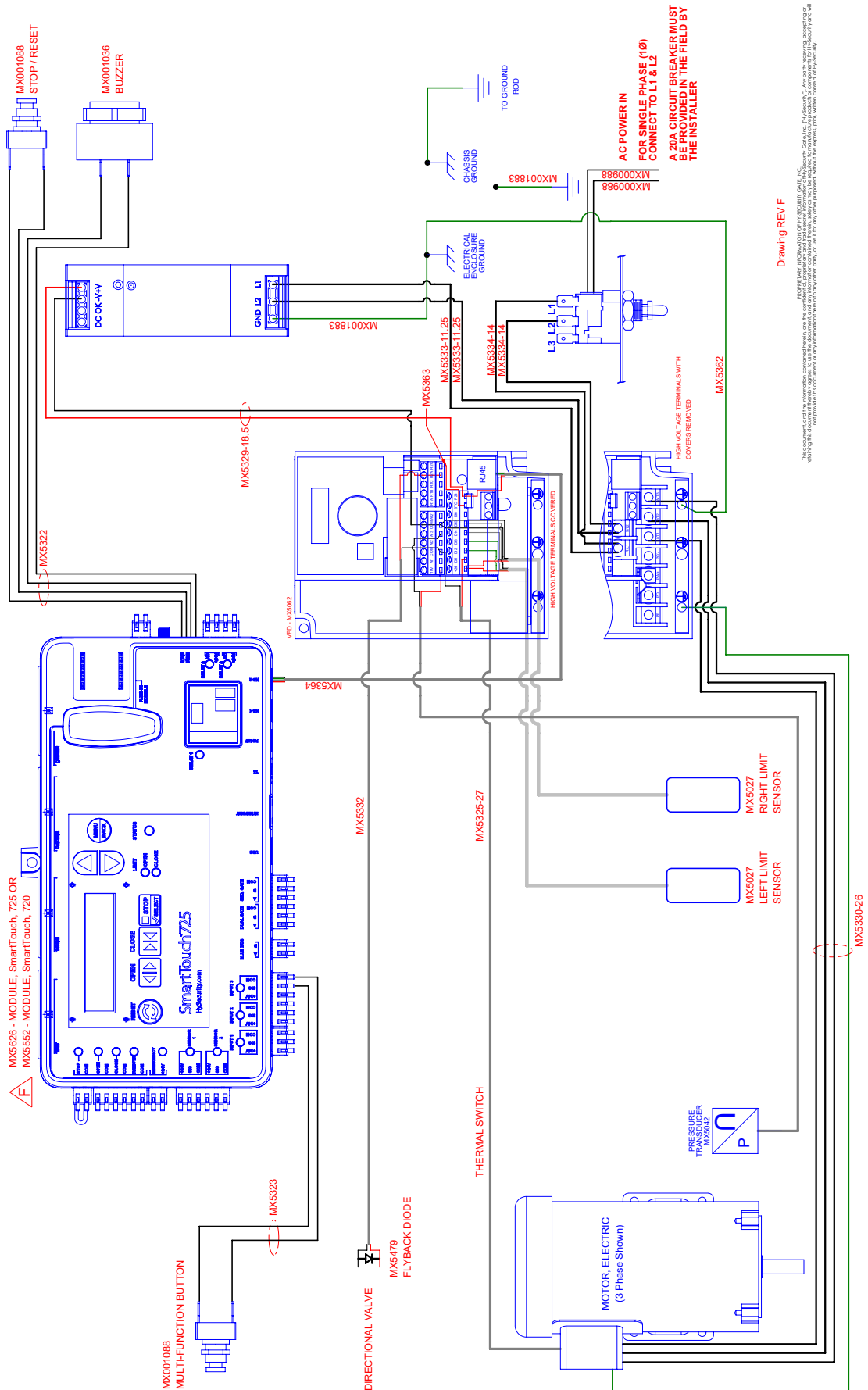

Drawing REV F

FOR THE LATEST INFORMATION ON HYSECURITY GATE, INC. PRODUCTS, VISIT [WWW.HYSECURITYGATE.COM](http://WWW.HYSECURITYGATE.COM). ALL RIGHTS RESERVED. ANY REPRODUCTION, STORAGE, OR TRANSMISSION OF THIS DOCUMENT IS STRICTLY PROHIBITED. THE INFORMATION CONTAINED HEREIN IS THE PROPERTY OF HYSECURITY GATE, INC. AND IS TO BE USED ONLY FOR THE PURPOSES SPECIFIED. THE INFORMATION CONTAINED HEREIN IS SUBJECT TO CHANGE WITHOUT NOTICE.

## SLIDEDRIVER II 50F 3Ø AC WIRING DIAGRAM

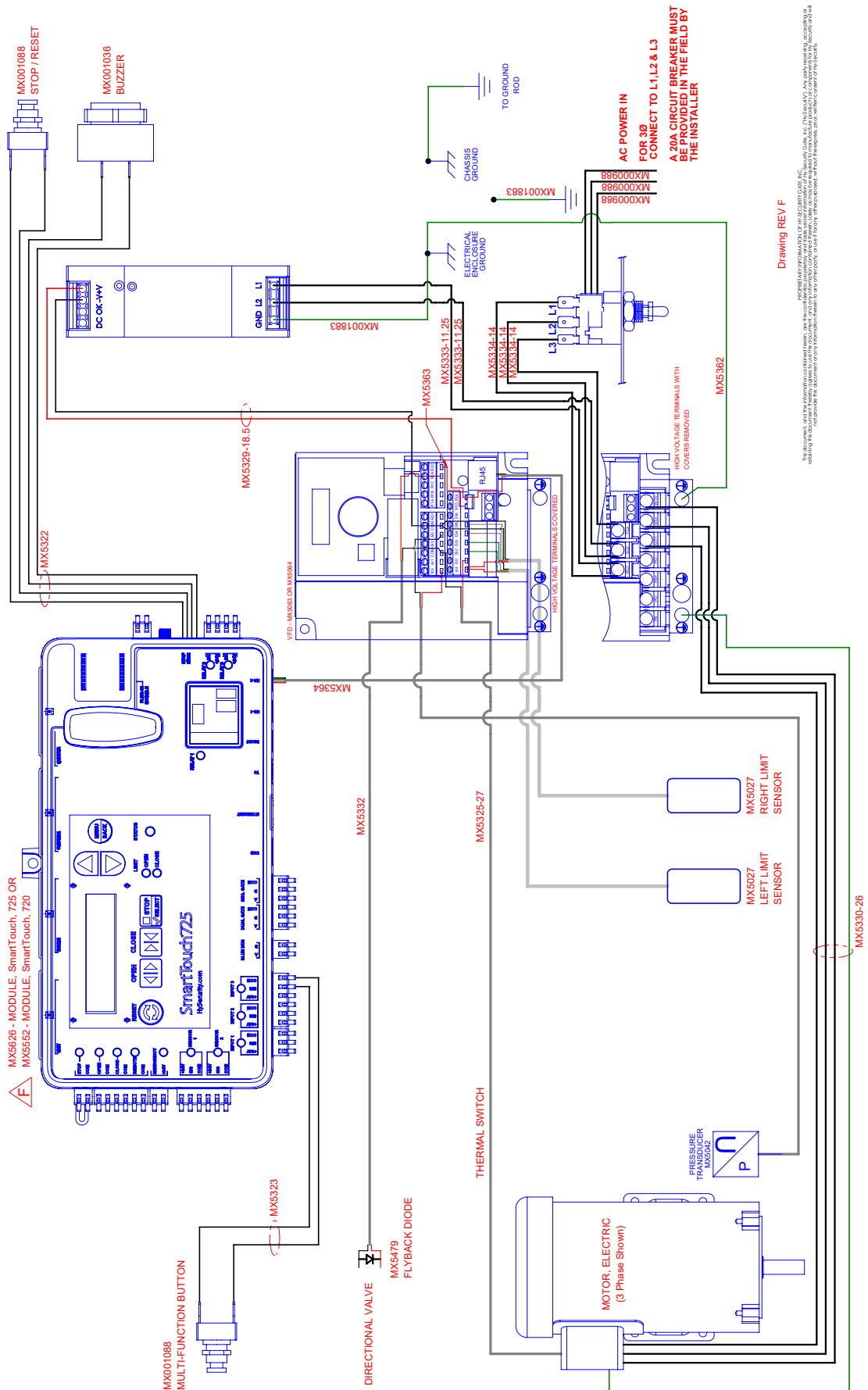

Drawing REV F  
 PROPRIETARY INFORMATION OF HYDRONET/GEAR, INC.  
 ALL RIGHTS RESERVED. THIS DOCUMENT IS THE PROPERTY OF HYDRONET/GEAR, INC. AND IS NOT TO BE REPRODUCED, COPIED, OR TRANSMITTED IN ANY FORM OR BY ANY MEANS, ELECTRONIC OR MECHANICAL, INCLUDING PHOTOCOPYING, RECORDING, OR BY ANY INFORMATION STORAGE AND RETRIEVAL SYSTEM. A 20A CIRCUIT BREAKER MUST BE PROVIDED IN THE FIELD BY THE INSTALLER.

# APPENDIX C - WIRING DIAGRAMS

## SLIDEDRIVER II 80V 1Ø AC WIRING DIAGRAM

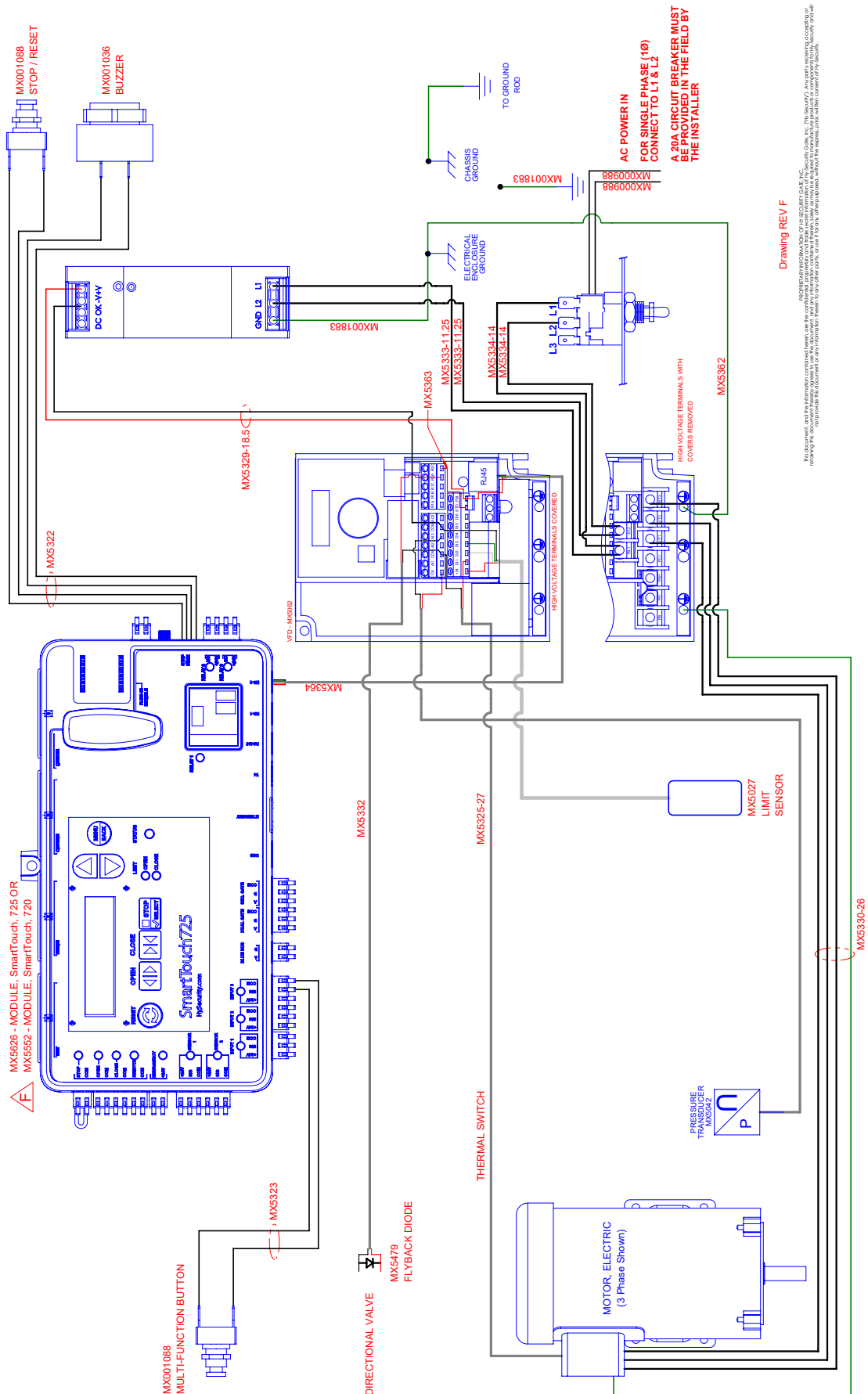

Drawing REV F



## SLIDEDRIVER II 80V 3Ø AC WIRING DIAGRAM

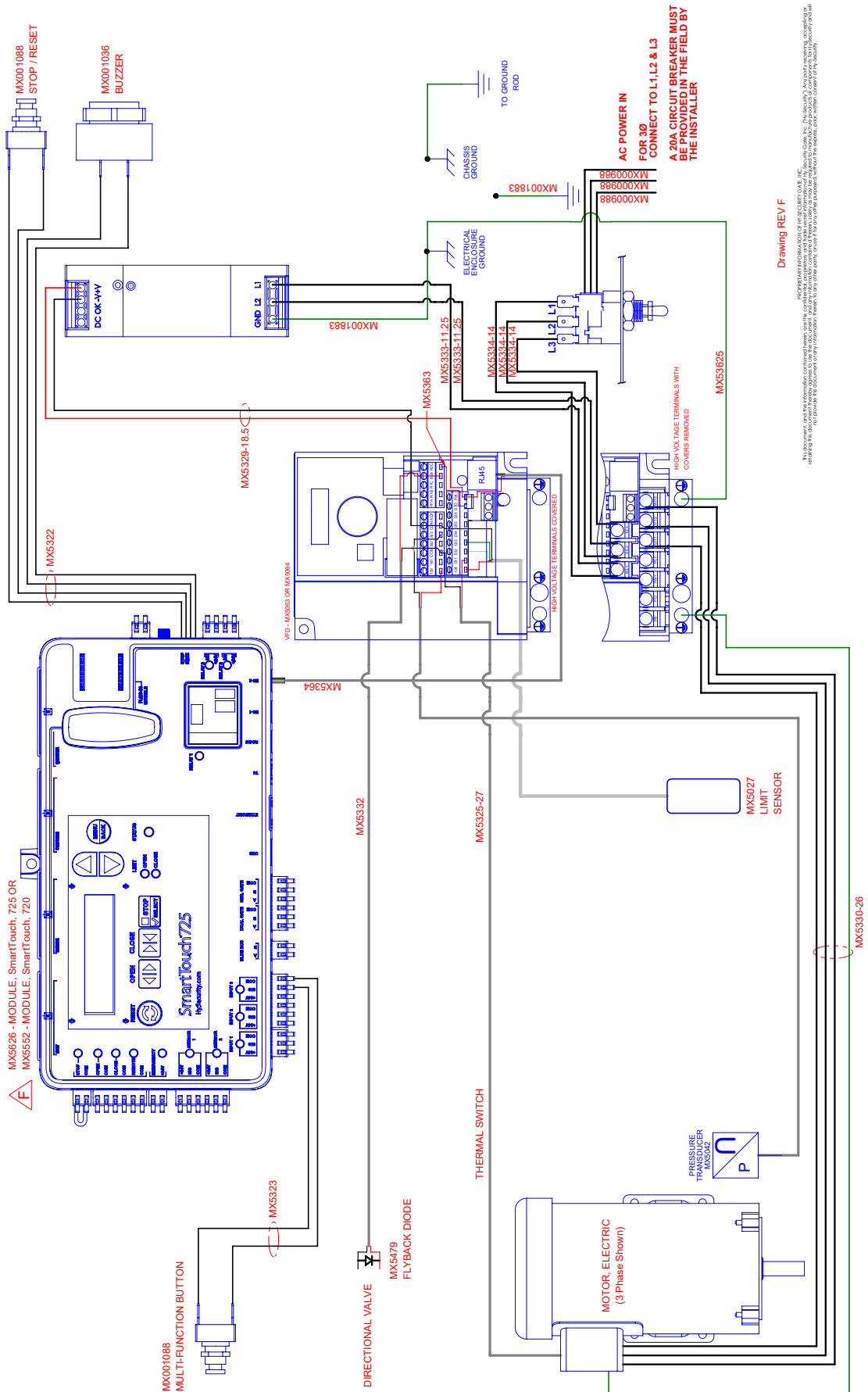

**AC POWER IN FOR 3Ø CONNECT TO L1, L2 & L3 A 20A CIRCUIT BREAKER MUST BE PROVIDED IN THE FIELD BY THE INSTALLER**

Drawing REV F

THIS DOCUMENT IS THE PROPERTY OF HYDRACON, INC. IT IS TO BE USED ONLY FOR THE PURPOSES INTENDED. IT IS NOT TO BE REPRODUCED OR TRANSMITTED IN ANY FORM OR BY ANY MEANS, ELECTRONIC OR MECHANICAL, INCLUDING PHOTOCOPYING, RECORDING, OR BY ANY INFORMATION STORAGE AND RETRIEVAL SYSTEM, WITHOUT THE EXPRESS WRITTEN PERMISSION OF HYDRACON, INC. THE INFORMATION CONTAINED HEREIN IS FOR INFORMATIONAL PURPOSES ONLY AND DOES NOT CONSTITUTE AN OFFER OF ANY FINANCIAL PRODUCT OR SERVICE. HYDRACON, INC. IS NOT RESPONSIBLE FOR ANY DAMAGES, INCLUDING CONSEQUENTIAL DAMAGES, ARISING FROM THE USE OF THIS DOCUMENT. HYDRACON, INC. IS NOT RESPONSIBLE FOR ANY DAMAGES, INCLUDING CONSEQUENTIAL DAMAGES, ARISING FROM THE USE OF THIS DOCUMENT.

# APPENDIX C - WIRING DIAGRAMS

## SLIDEDRIVER II 200V 3Ø WIRING DIAGRAM

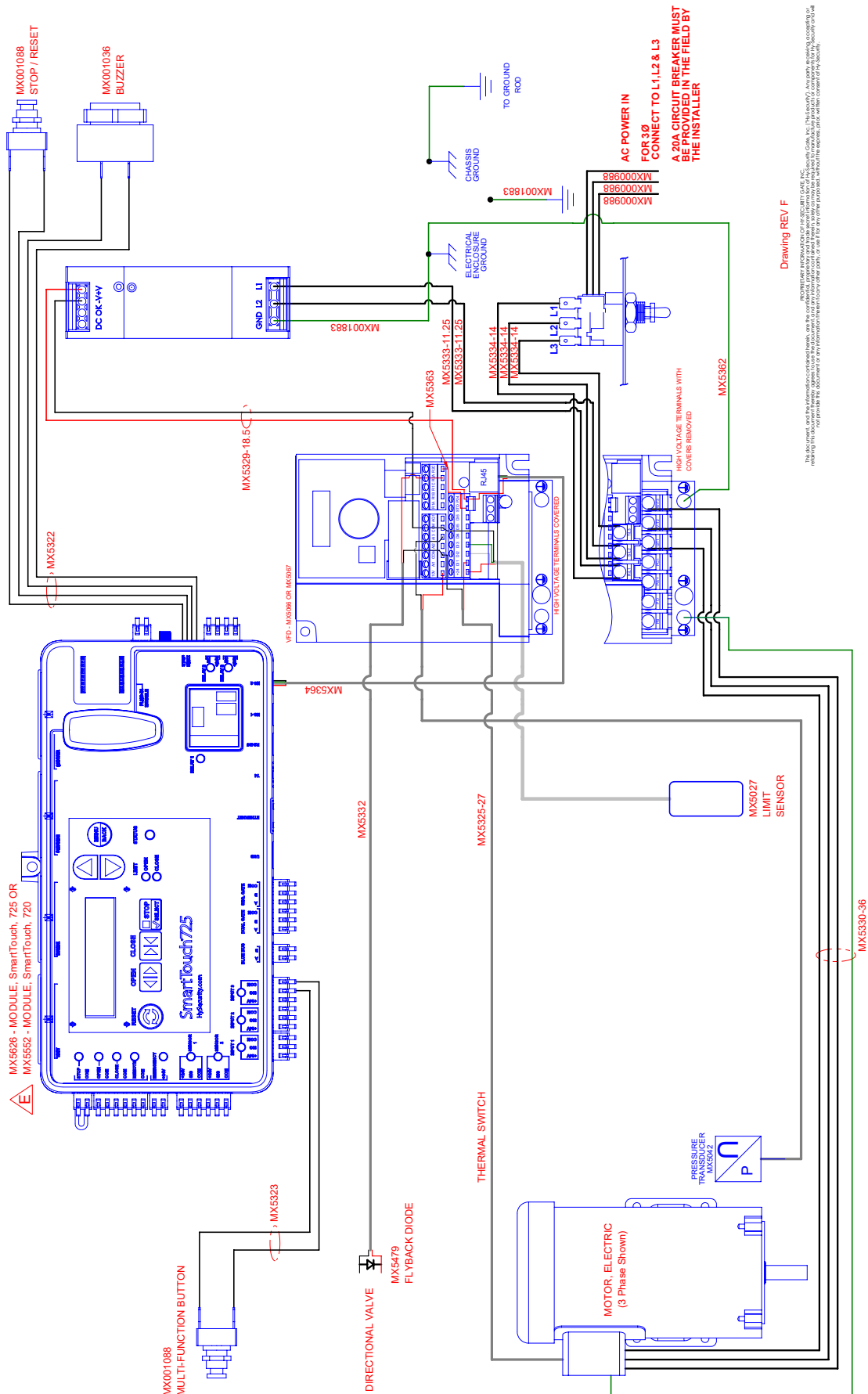

Drawing REV F

INDUSTRIAL INFORMATION OF HYSECURITY, INC.  
 ALL RIGHTS RESERVED. THIS DOCUMENT IS THE PROPERTY OF HYSECURITY, INC. AND IS NOT TO BE REPRODUCED, COPIED, OR TRANSMITTED IN ANY FORM OR BY ANY MEANS, ELECTRONIC OR MECHANICAL, WITHOUT THE WRITTEN PERMISSION OF HYSECURITY, INC. ANY UNAUTHORIZED REPRODUCTION OR TRANSMISSION OF THIS DOCUMENT IS STRICTLY PROHIBITED. THE INFORMATION CONTAINED HEREIN IS UNCLASSIFIED AND IS NOT SUBJECT TO EXPORT CONTROL. THE INFORMATION CONTAINED HEREIN IS UNCLASSIFIED AND IS NOT SUBJECT TO EXPORT CONTROL.



# SLIDEDRIVER II INSTALLER CHECKLIST

---

This checklist is provided by HySecurity and is to be used after installing a SlideDriver II gate operator.

1. Read, understand, and follow the Safety Requirements section (page 3 - page 9) of this document throughout the commissioning and installation process.
2. Before checking the items in this list, make sure power is turned OFF at the main power disconnect and the operator's control box power switch is also in the OFF position.
3. Lower the toggle handle to unclamp the drive wheels from the drive rail and check the following:

- Gate moves smoothly and freely by hand.
- WARNING placards mounted on both sides of the gate within sight of vehicle and pedestrian traffic per UL 325 requirements.
- Electric motor wired properly.
- Incoming power supply voltage matches the label on the motor and control box.
- Gate operator is level.
- Operator is labeled as appropriate for both the type and UL usage class of the gate.

Make sure  $\emptyset$ , hertz, and power match the operator and its labeling:

- 1  $\emptyset$        3  $\emptyset$        50 Hz       60 Hz
- DC-24V     115 VAC     208 VAC     230 VAC     480 VAC     \_\_\_ V

- Power cable run to the operator is of sufficient wire size to handle starting current.
  - NEC/NFPA ground rod is installed.
  - All wires and cables are clear of moving parts (limits, valves, power, etc.).
  - Breather cap has been installed, replacing the Vent Plug in the pump.
  - Oil level checked.
  - All chassis and base riser bolts are tight.
  - Gate wheels & rollers have covers.
  - Pinch points protected.
  - Permanently mounted controls intended for user activation must be located at least 6 ft (1.83 m) away from any moving part of the gate and where the user is prevented from reaching over, under, around or through the gate to operate the controls.
  - Pedestrian gate exists.
  - Physical gate stops are present.
  - On gate, protective mesh complies with ASTM F2200 and UL 325 standards.
  - Gate is not on a slope.
4. For the remaining checks, you want to cycle test the gate operator. To do so,
    - Temporarily, disconnect any peripheral devices except external entrapment sensors.
    - Re-engage the wheels by lifting the toggle handle and clamping the drive wheels onto the drive rail.
    - Turn the main power ON, and then turn ON the power switch located on the operator's control box.

# SLIDEDRIVER II INSTALLER CHECKLIST

5. Prior to moving the gate, make sure the wheel clamp spring is compressed to 2 in (50 mm).
6. Cycle test the gate by pressing the CLOSE and OPEN buttons. Allow the gate to continue traveling throughout its entire range while you or your assistant checks the following:
  - Gate handing is set correctly. See product literature for information on gate handing.
  - Horizontal rail surface is: Advanced Drive 9¼ in to 9¾ in (230 mm to 250 mm) or XtremeDrive 9½ in to 10 in (240 mm to 255 mm) above the pad over full gate travel.
  - Rail flange, attached to the gate supports, remains at a distance of 1¾ in ± ⅛ in (40 mm ± 3 mm) from the outside edge of the operator (edge closest to the gate panel) over the full range of gate travel.
  - Drive wheel face(s) are parallel to the rail ± ⅛ in (3 mm) with a 24 in (610 mm) straight edge.
  - The Dual Limit Sensor is adjusted to clear the drive rail while centered over the Limit Flags.
  - Limit Flags are adjusted to stop the gate at least 2 in (50 mm) from the end of travel.
7. External entrapment protection sensors, accessories, and options have been installed tested and comply with UL 325 Standard of Safety.

8. Check all those that apply:

- |   |  |   |  |
|---|--|---|--|
| <input type="checkbox"/> Free exit      | <input type="checkbox"/> Inside Obstruction Loop | <input type="checkbox"/> Outside Obstruction Loop |  |
| <input type="checkbox"/> Open edge      | <input type="checkbox"/> Close edge              | <input type="checkbox"/> Open photo eye           | <input type="checkbox"/> Close photo eye |
| <input type="checkbox"/> Stop input (1) | <input type="checkbox"/> Local Open (2)          | <input type="checkbox"/> Close timer set (3)      | <input type="checkbox"/> Radio open (4)  |
| <input type="checkbox"/> IES sensor     | <input type="checkbox"/> Fire Dept. Open         | <input type="checkbox"/> Emergency Close          | <input type="checkbox"/> Solenoid lock   |

Other accessories and important settings: \_\_\_\_\_

9. Safety sensors and other I/O programmed properly.

Date: \_\_\_\_\_

Operator Serial Number: \_\_\_\_\_

Installer Name and contact (please print): \_\_\_\_\_

End user's name and contact (please print): \_\_\_\_\_

Site address: \_\_\_\_\_

\_\_\_\_\_

\_\_\_\_\_

\_\_\_\_\_

Notes: \_\_\_\_\_

\_\_\_\_\_

# WARRANTY

## 1. Warranty.

HySecurity Gate, Inc. ("HySecurity") warrants that at the time of sale each HySecurity-branded product that it sells will, in all material respects, conform to its then applicable specification and will be free from defects in material and manufacture.

The following additional durational warranties apply to HySecurity products, depending on whether (1) the product is purchased through an authorized HySecurity distributor and (2) whether a timely and complete product registration is submitted to HySecurity.

*It is therefore important that you register your product with HySecurity, online at [www.hysecurity.com/warranty](http://www.hysecurity.com/warranty), within the 60-day period described below.*

### 1(a) HySecurity Products Purchased Through Authorized Distributors and Properly Registered

For any gate operator product that is purchased from an authorized HySecurity distributor (this excludes product purchased through internet resellers or any distributor not authorized by HySecurity), if the product registration is completed by the Dealer/Installer or End User within 60 days of the date of purchase, the following warranty terms will apply. HySecurity warrants that the product will remain serviceable for the following periods:

- a) Hydraulic industrial gate operator hydraulics, controls, and mechanical components: Five Years or 500,000 gate cycles (whichever occurs first) after the date of installation,
  - b) Hydraulic wedge operator hydraulics and controls: Five Years or 500,000 cycles (whichever occurs first) after the date of installation. Wedge mechanical components: Two Years after the date of installation,
  - c) Electromechanical pad-mounted Slide and Swing operators: Five Years or 500,000 cycles (whichever occurs first) after the date of installation, except single family residential usage, where the warranty term shall be Seven Years after the date the product was shipped from HySecurity,
  - d) Electromechanical linear actuator Swing operators: Two Years after the date of installation,
  - e) Electromechanical surface mount wedge operator electronics: Two Years or 500,000 gate cycles (whichever occurs first), after the date of installation,
  - f) Electromechanical Barrier Arm Operators: Two years or 1,000,000 gate cycles (whichever occurs first) after the date of installation,
- provided that* the preceding Five Year warranty period in (a), (b), and (c) will not extend beyond seven years from the date that the product was shipped from HySecurity, and the Two Year warranty period in (b), (d), (e), and (f) will not extend beyond four years from the date that the product was shipped from HySecurity.

The preceding warranty durations do not apply to the products or components described below (g-j), which have a shorter warranty period:

- g) Hydraulic gate operator drive wheels, including XtremeDrive™ wheels and rack: Two Years from date of installation.
- h) AC and DC power supplies, chargers, and inverters and HyNet™ Gateway: Two Years from date of installation, except batteries.
- i) Batteries: One Year from date of shipment from HySecurity.
- j) Components subject to normal wear including, but not limited to, chains, belts, idler wheels, sprockets and fuses: One Year from date of installation.

### 1(b) HySecurity Products Not Purchased Through an Authorized Distributor or Not Properly Registered within 60 Days

For any product that is not purchased from an authorized HySecurity distributor or for which the product registration was not completed by the Dealer/Installer/End User within sixty (60) days of the date of purchase, the following warranty will apply: HySecurity warrants that the product will remain serviceable for the following periods, which begin on the date that the product was shipped from HySecurity:

- a) All gate operators: One Year or 100,000 gate cycles, whichever comes first.
- b) AC and DC power supplies, chargers, or inverters: One Year.
- c) HyNet™ Gateway: One Year.
- d) Hydraulic gate operator drive wheels: One Year.

### 1(c) Replacement Parts

HySecurity warrants that replacement parts (whether new or reconditioned) will remain serviceable for One Year from the date that the part was shipped from HySecurity or the remaining period of the Gate Operator warranty, whichever is longer.

### 1(d) Limitations and Exclusions Applicable to Each of the Preceding Warranties.

The preceding warranties shall not apply to equipment that has been (1) installed, maintained, or used improperly or contrary to instructions; (2) subjected to negligence, accident, vandalism, or damaged by severe weather, wind, flood, fire,

terrorism or war; or (3) damaged through improper operation, maintenance, storage or abnormal or extraordinary use or abuse. Any modification made to products will void the warranty unless the modifications are approved in writing by HySecurity in advance of the change (this exclusion does not apply to normal installation of approved accessories and/or protective devices or sensors). It is the responsibility of the Distributor, Dealer/Installer, or End User to ensure that the software version in the product is maintained to the latest revision level.

The preceding warranties do not extend to accessories when those items carry another manufacturer's name plate and they are not a part of the base model. HySecurity disclaims all warranties for such accessory components, which carry only the original warranty, if any, of their original manufacturer. HySecurity hereby assigns its rights under such manufacturer warranties—to the extent that such rights are assignable—to Buyer.

These warranties extend to HySecurity's Distributors, to the Dealer/Installer, and to the first End User of the product following installation. They do not extend to subsequent purchasers.

## 2. Exclusion of Other Warranties.

The warranties contained in Section 1 are the exclusive warranties given by HySecurity and supersede any prior, contrary or additional representations, whether oral or written. Any prior or extrinsic representations or agreements are discharged or nullified. HYSECURITY HEREBY DISCLAIMS AND EXCLUDES ALL OTHER WARRANTIES—WHETHER EXPRESS, IMPLIED, OR STATUTORY—INCLUDING ANY WARRANTY OF MERCHANTABILITY, ANY WARRANTY OF FITNESS FOR A PARTICULAR PURPOSE, ANY LIABILITY FOR INFRINGEMENT, AND ANY WARRANTIES OTHERWISE ARISING FROM COURSE OF DEALING, COURSE OF PERFORMANCE, OR USAGE OF TRADE.

## 3. Buyer's Exclusive Remedies for Any Nonconformity.

If a HySecurity product fails to conform to the warranties in Section 1, Buyer must notify and order replacement parts from the Distributor through which the product was purchased within a reasonable time and in no event more than thirty (30) days after the discovery of the nonconformity. HySecurity will investigate and, in the event of a breach, will provide, within a reasonable period of time, one of the following: (1) repair or replacement of any nonconforming products or components or (2) refund of the price upon return of the nonconforming items. HySecurity reserves the right to supply used or reconditioned material for all warranty claims. HySecurity will not be considered to be in breach of or default under this Warranty because of any failure to perform due to conditions beyond its reasonable control, including any force majeure. This warranty does not cover any incidental expenses, including fines or penalties, temporary security, labor, shipping, travel time or standby time that are incurred for inspection or replacement of any nonconforming items. As a condition of warranty coverage, warranty claims must be submitted in accordance with the procedures described on the HySecurity form, "RMA Procedures."

THE REMEDY SELECTED BY HYSECURITY IN ACCORDANCE WITH THIS PARAGRAPH SHALL BE THE EXCLUSIVE AND SOLE REMEDY OF BUYER FOR ANY BREACH OF WARRANTY.

## 4. Exclusion of Consequential and Incidental Damages.

HYSECURITY SHALL NOT BE LIABLE FOR ANY INCIDENTAL, SPECIAL, OR CONSEQUENTIAL DAMAGES, WHETHER RESULTING FROM NONDELIVERY OR FROM THE USE, MISUSE, OR INABILITY TO USE THE PRODUCT OR FROM DEFECTS IN THE PRODUCT OR FROM HYSECURITY'S OWN NEGLIGENCE. This exclusion applies regardless of whether such damages are sought for breach of warranty, breach of contract, negligence, or strict liability. This exclusion does not apply to claims for bodily injury or death.

## 5. Severability.

If any provision of this warranty is found to be invalid or unenforceable, then the remainder shall have full force and effect.

## 6. Proprietary Rights.

HySecurity retains and reserves all right, title, and interest in the intellectual property rights of its products, including any accompanying proprietary software. No ownership of any intellectual property rights in the products or accompanying software is transferred to Distributor, Dealer/Installer, or End User.

## 7. Applicable Law.

This warranty will be interpreted, construed, and enforced in all respects in accordance with the laws of the State of Washington, without reference to its choice of law principles. The U.N. Convention on Contracts for the International Sale of Goods will not apply to this warranty.

## Technical Specifications

Model	SlideDriver II SD15	SlideDriver II SD40	SlideDriver II SD50F	SlideDriver II SD80V	SlideDriver II SD200V
Duty Cycle	Continuous				
Horsepower	1 hp	1 hp; DC Option 2 hp	2 hp		5 hp; DC Option 4 hp
Drive	Hydraulic		Hydraulic with VFD motor control		
Drive Wheels	Two 6 inch (15 cm) AdvanceDrive wheels		Two 8 inch (20 cm) AdvanceDrive wheels	One 8 inch (20 cm) AdvanceDrive wheel, One 8 inch XtremeDrive wheel and 27 ft (8 m) of rack	Two 8 inch (20 cm) AdvanceDrive wheels, Two 8 inch XtremeDrive wheels and 52 ft (16 m) of rack
Rate of Travel	1 ft/s (30 cm/s)		Field adjustable, 2.2 ft/s (70 cm/s) or 3 ft/s (91 cm/s). Emergency Fast Operate 3 ft/s (91 cm/s)	Field adjustable, .75 ft/s (23 cm/s) or 1 ft/s (30 cm/s).	
Gate Length Max.	Limited only by weight				
Gate Weight Max.	Up to 1,500 lb (680 kg)	Up to 4,000 lb (1,814 kg)	Up to 5,000 lb (2,268 kg)	Up to 8,000 lb (3,629 kg)	Up to 20,000 lb (9,072 kg)
Pull Force	300 lb (136 kg)			600 lb (272 kg)	1,200 lb (544 kg)
UpS Battery BackUp Cycles*	Optional 230V AC Power Supply w/HyInverter AC™	Select option SB-2-2J for DC configuration. Requires DC Power Supply DCPS-60, purchased separately.	Optional 230V AC Power Supply w/HyInverter AC™		Select option SB-2-2T for DC configuration. Requires DC Power Supply DCPS-150 ordered separately.**
Temperature Rating	-40° to 158° F (-40° to 70° C)				
Single Phase Voltages	115/208-230V 60 Hz, 110/220V 50 Hz***		208-230V 60Hz,220V 50Hz***		N/A
Three Phase Voltages	208-230/460V 60Hz,220/380/440V 50Hz***				
Included Accessories	One premium EMX IRB-MON photo eye, one 5-foot premium ASO edge sensor				N/A
Communication	BlueBUS, USB, Ethernet, T4, RS-485, Bluetooth, OXI receiver				
User Controls	SmartTouch 725 Controller with 70+ configurable settings. 32 character OLED display and 7 tactile buttons, or Bluetooth smartphone interface, for programming. SmartTouch 720 Available without Bluetooth or Ethernet.				
Relays	8 Configurable relays: Two 250V 20A electromechanical relays and six 30VDC 2A solid state relays		Three configurable user relays: Two 30VDC 2A solid state, one 240VAC, 20A electromechanical. Optional I/O Expansion module for 8 additional relay outputs.		
Enclosure	N/A				
Finish	Zinc plated with powder coating				
ETL Listed (UL 325)	Usage Class I, II, III, IV		Usage Class III, IV		
Warranty	5 year w/product registration				

\*The actual number of gate cycles available from battery depends upon gate resistance to travel, cycle length, battery size, state of charge and health, ambient temperature, accessory power draw and frequency of gate cycles during power outage.

\*\*SlideDriver II SD200 UPS has a 2,000 ft/hr (610 m/hr) expected duty cycle. Actual duty cycle depends on site specific conditions and gate configuration.

\*\*\*Refer to Installed Options on pricing for all 50Hz voltages, which are special order.

### Contact Information:

Visit [support.hysecurity.com](http://support.hysecurity.com) for Installation manuals, replacement part instructions, part diagrams and more.

Qualified Nice | HySecurity distributors are experienced and trained to assist in resolving installation problems. For the name of a qualified distributor near you, call HySecurity at 800-321-9947. \*Before contacting your distributor or HySecurity Technical Support, obtain the serial number of your operator.

Part	Version
System firmware	h6.06
SmartTouch 720/725 Controller	RevA, RevC

Note: If the versions above do not match your operator visit the website in Contact Information below for a manual that matches your operator.



Nice North America | HySecurity  
Gate & Barrier Division  
6705 S 209th St, Ste 101  
Kent, WA 98032

[hysecurity.com](https://www.hysecurity.com)

MX5386-01 REV. B 02-23-2023 | PN: 901227145