

**CHAMBERLAIN®**

# LiftMaster®

**PROFESSIONAL**

INSTALLATION/OPERATION MANUAL

## MODEL LA400

MEDIUM DUTY SWING GATE OPERATOR

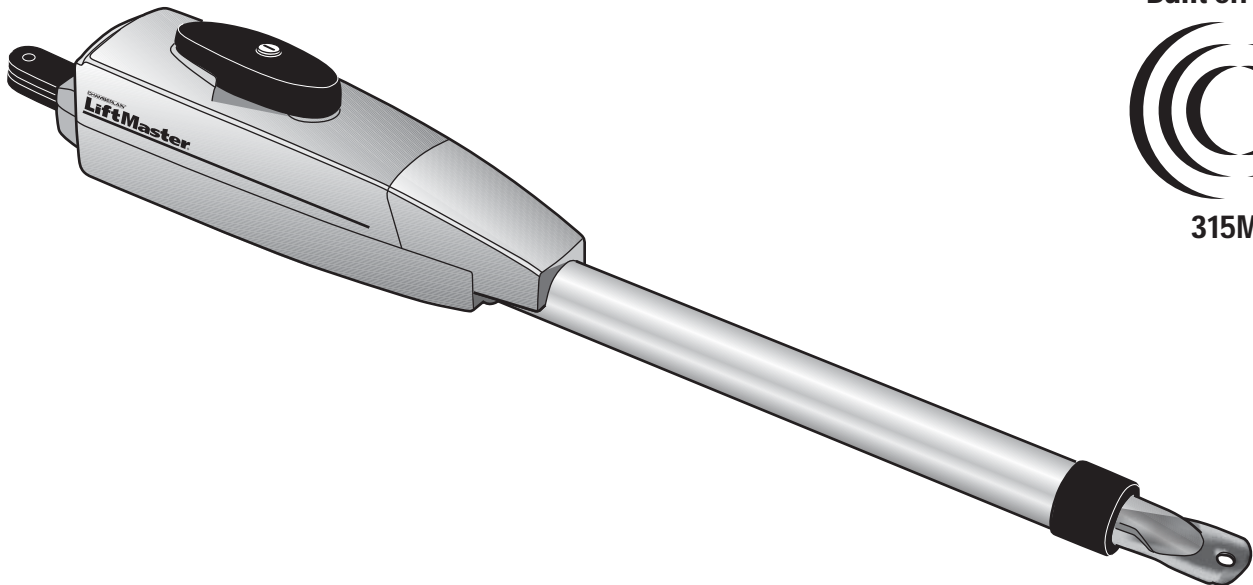

Radio Receiver  
Built on Board

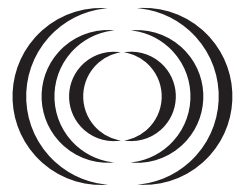

315MHz

**2 YEAR WARRANTY**

Serial # Primary Arm \_\_\_\_\_



Serial # Secondary Arm \_\_\_\_\_

Serial # Control Box \_\_\_\_\_

Installation Date \_\_\_\_\_



# TABLE OF CONTENTS

<b>Introduction</b>	<b>2-5</b>	Loop Inputs	31
Carton Inventory	3	Photo/Edge Inputs (P6-7-8 and 9)	32
Additional Items Needed for Installation	3	Safety Accessories for Secondary Entrapment Protection	33
Operator Dimensions and Specifications	3	<b>Operation</b>	<b>34</b>
UL325 Classifications	4	Reset Button	34
Safety Installation Information	5	Remote Control	34
<b>Overview of Typical Installation</b>	<b>6-10</b>	Manual Release	34
Left-Hand Gate	6	<b>Maintenance</b>	<b>35-36</b>
Right-Hand Gate	6	Battery Replacement	36
Dual Gate	7	<b>Basic Control Board Layout</b>	<b>37</b>
Safety Precautions for Swing and Ornamental “Grill Type Gates”	8	<b>Wiring Diagram</b>	<b>38</b>
Warning Sign Placement	8	<b>Troubleshooting</b>	<b>39-40</b>
Before Installation Check Your Gate	9	<b>Repair Parts</b>	<b>41-42</b>
Mounting Options	10	<b>LA400 Swing Gate Accessories</b>	<b>43</b>
<b>Installation</b>	<b>11-18</b>	<b>Warranty Policy and Service</b>	<b>44</b>
Step 1: Manual Release	11	<b>INTRODUCTION</b>	
Step 2A: Determine Position of the Pull-to-Open Bracket	12	 <b>WARNING</b>	
Step 2B: Determine Position of the “Optional” Push-to-Open Bracket (Not Provided)	12	<b>Mechanical</b>	
Step 3: Determine Mounting Location	13	 <b>WARNING</b>	
Step 4: Assemble Gate Post Bracket (Pull-to-Open)	13	<b>Electrical</b>	
Step 5: Attach Bracket to Arm	14	<b>CAUTION</b>	
Step 6: Position Operator on Gate	14	When you see these Safety Symbols and Signal Words on the following pages, they will alert you to the possibility of <b>serious injury</b> or <b>death</b> if you do not comply with the warnings that accompany them. The hazard may come from something mechanical or from electric shock. Read the warnings carefully.	
Step 7: Test Gate Travel	15	When you see this Signal Word on the following pages, it will alert you to the possibility of damage to your gate and/or the gate operator if you do not comply with the cautionary statements that accompany it. Read them carefully.	
Step 8: Secure Gate Post Bracket to Gate Post	16	<b>IMPORTANT NOTE</b>	
Step 9: Secure Gate Bracket to Gate	16	• BEFORE attempting to install, operate or maintain the operator, you must read and fully understand this manual and follow all safety instructions.	
Step 10: Warning Sign Placement	17	• DO NOT attempt repair or service of your commercial door and gate operator unless you are an Authorized Service Technician.	
Step 11: Open the Control Box	18	<b>TOOLS NEEDED FOR INSTALLATION</b>	
Step 12: Select Mounting Holes	18	During assembly, installation and adjustment of the operator the tools listed below will be needed.	
Step 13: Mount Control Box	18	• Wrench or Socket Set	
<b>Motor Wiring</b>	<b>19-20</b>	• Phillips Head Screwdriver	
Step 1: Watertight Connector Nut	19	• C Clamps	
Step 2: Insert Operator Cable	19	• Level	
Step 3: Connect Operator to Control Board	20	• Small Screwdriver	
<b>Power Wiring</b>	<b>21-22</b>	• T25 Torx Head Screwdriver	
Connect Transformer to Control Board	21		
Earth Ground Rod Installation (Optional)	22		
<b>Control Wiring</b>	<b>23</b>		
<b>Adjusting/Running the Operator</b>	<b>24-26</b>		
Step 1: Set Dip Switch	24		
Step 2: Program Limits	25		
Step 3: Set Force/Bi-part/Timer	26		
<b>Optional Control and Safety Device Wiring</b>	<b>27-33</b>		
To Add or Reprogram a Remote Control	27		
Dip Switch Settings	28		
Wire Stop Button (Optional)	29		

# Carton Inventory

HARDWARE KIT		CONTROL BOX LA400 - CONT	
DESCRIPTION	QTY	DESCRIPTION	QTY
Post Bracket	1	Control Box	1
Pull to Open Bracket	1	Hardware Bag	1
Hex Bolt 5/16"-18 X 1-1/2"	5	<b>MISCELLANEOUS</b>	
Square Neck Carriage Bolt 3/8"-16 X 6"	2	Linear Actuator Arm	
Hex Nut 3/8"-16	2	Motor Cable - Six Conductor	9' (2.7 m)
Hex Nut 5/16"-18	5	Warning Sign	2
Flat Washer 5/16"	5	Battery	2
Flat Washer 3/8"	5	Plug-In Transformer	1
Lock Washer 5/16"	5	<b>LA400-S (SECOND LINEAR ACTUATOR ARM)</b>	
Lock Washer 3/8"	5	Extension Cable - Six Conductor	40' (12.2 m)
Gate Mounting Bracket	1	Junction Box - IP56	1
Hairpin Clip	4	Phillips Head Mounting Screws	4
Pin	2	Anchors	4
Hex Bolt 3/8"-16 X 1-1/2"	1	Terminal Block - Twelve Connectors	1
Bolt 2-3/4"	2		

**NOTE:** Carton inventory is based on a Single Operator. For Primary (Gate 1) and Secondary (Gate 2) installation the carton inventory is doubled except for control box.

## Additional Items Needed for Installation

Permanent fasteners for warning sign			
Earth Ground Rod (Optional)			
Power Wire: 120Vac (Stranded Copper Wire)		Power Wire: 24Vac Transformer (Stranded Copper Wire)	
Wire Gauge	Length	Wire Gauge	Length
16	100' (30 m)	14	500' (152 m)
10	1000' (305 m)	12	1000' (305 m)

## Operator Dimensions and Specifications

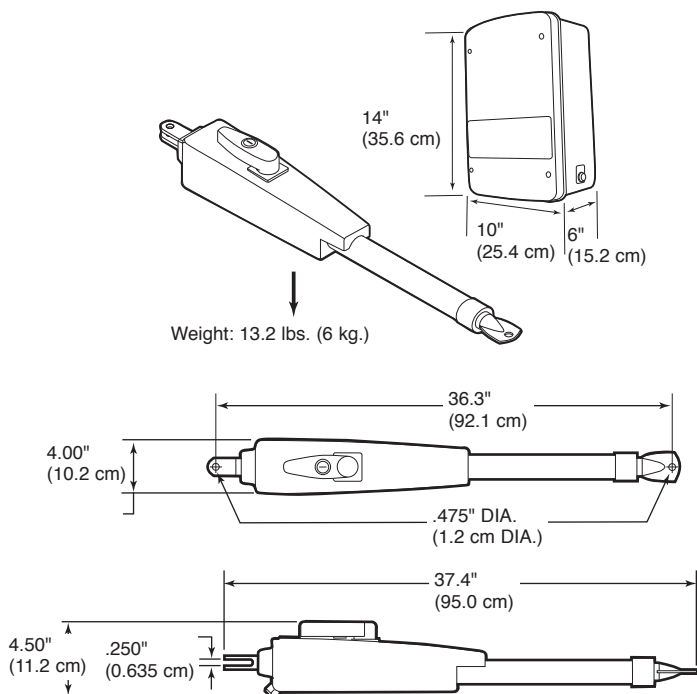

Operating Cycles	100 per day
Main Supply (Motor)	24Vdc
Current Consumption	2A
Power Consumption	48 Watts
Battery Charger Supply	26Vac, 29VA or 36Vdc, 40VA
Solar Panel Supply (Optional)	See Accessories
Maximum Gate Width	16 ft. (4.9 m)
Maximum Gate Weight	550 Lbs. (249.5 kg)
Protection Class	NEMA 3R
Travel Speed	14-18 seconds for a 90 degree opening
Rated Operating Time	4 Minutes
Temperature	-20°C to + 50°C -4°F to + 122°F
Main Supply (Control) Dedicated Circuit	120V~/60Hz
Absorbed Power	0.75 Watts
Protection Fuse Battery	ATC 20A

# UL325 Model Classifications

The LA400 is intended for use with vehicular swing gates. The operator can be used in Class I, Class II and Class III applications.



## CLASS I – RESIDENTIAL VEHICULAR GATE OPERATOR

A vehicular gate operator (or system) intended for use in a home of one-to four single family dwelling, or a garage or parking area associated therewith.

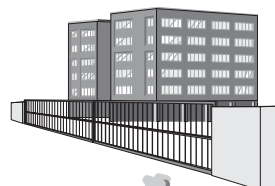

## CLASS II – COMMERCIAL/GENERAL ACCESS VEHICULAR GATE OPERATOR

A vehicular gate operator (or system) intended for use in a commercial location or building such as a multi-family housing unit (five or more single family units) hotel, garages, retail store or other building servicing the general public.

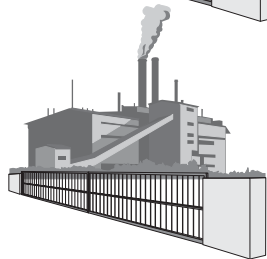

## CLASS III – INDUSTRIAL/LIMITED ACCESS VEHICULAR GATE OPERATOR

A vehicular gate operator (or system) intended for use in an industrial location or building such as a factory or loading dock area or other locations not intended to service the general public.

### SAFETY ACCESSORY SELECTION

All UL325 compliant LiftMaster gate operators will accept external entrapment protection devices to protect people from motorized gate systems. UL325 requires that the type of entrapment protection correctly matches each gate application. Below are the four types of entrapment protection systems recognized by UL325 for use on this operator.

### ENTRAPMENT PROTECTION TYPES

- Type A: Inherent obstruction sensing system, self-contained within the operator. This system must sense and initiate the reverse of the gate within two seconds of contact with a solid object.
- Type B1: Connections provided for a non-contact device, such as a photoelectric eye can be used as a secondary protection.
- Type B2: Connections provided for a contact sensor. A contact device such as a gate edge can be used for secondary protection.
- Type E: Built-in audio alarm. Examples include sirens, horns or buzzers.

**NOTE:** UL requires that all installations must have warning signs placed in plain view on both sides of the gate to warn pedestrians of the dangers of motorized gate systems.



### UL325 ENTRAPMENT PROTECTION REQUIREMENTS

Gate Operator Entrapment Protection		
UL325 Installation	Swing and Gate Barrier (Arm) Operator	
Class	Primary Type	Secondary Type
Class I and II	A	A, B1 or B2
Class III	A, B1 or B2	A, B1, B2 or E

The chart above illustrates the entrapment protection requirements for each of the three UL325 classes.

In order to complete a proper installation you must satisfy the entrapment protection chart shown above. That means that the installation must have one primary means of entrapment protection and one independent secondary means of entrapment protection. Both primary and secondary entrapment protection methods must be designed, arranged or configured to protect against entrapments in both the open and close directions of gate travel.

**For Example:** For a slide gate system that is installed on a single-family residence (UL325 Class I) you must provide the following: As your primary type of entrapment protection you must provide Type A inherent (built into the operator) entrapment sensing and at least one of the following as your secondary entrapment protection: Type B1- Non-contact sensors such as photoelectric eyes, Type B2- Contact sensors such as gate edges.



## Safety Installation Information

1. Vehicular gate systems provide convenience and security. Gate systems are comprised of many component parts. The gate operator is only one component. Each gate system is specifically designed for an individual application.
2. Gate operating system designers, installers and users must take into account the possible hazards associated with each individual application. Improperly designed, installed or maintained systems can create risks for the user as well as the bystander. Gate systems design and installation must reduce public exposure to potential hazards.
3. A gate operator can create high levels of force in its function as a component part of a gate system. Therefore, safety features must be incorporated into every design. Specific safety features include:
  - Gate Edges
  - Guards for Exposed Rollers
  - Photoelectric Sensors
  - Screen Mesh
  - Vertical Posts
  - Instructional and Precautionary Signage
4. Install the gate operator only when:
  - a. The operator is appropriate for the construction and the usage class of the gate.
  - b. All openings of a horizontal slide gate are guarded or screened from the bottom of the gate to a minimum of 4' (1.2 m) above the ground to prevent a 2-1/4" (6 cm) diameter sphere from passing through the openings anywhere in the gate, and in that portion of the adjacent fence that the gate covers in the open position.
  - c. All exposed pinch points are eliminated or guarded, and guarding is supplied for exposed rollers.
5. The operator is intended for installation only on gates used for vehicles. Pedestrians must be supplied with a separate access opening. The pedestrian access opening shall be designed to promote pedestrian usage. Locate the gate such that persons will not come in contact with the vehicular gate during the entire path of travel of the vehicular gate.
6. The gate must be installed in a location so that enough clearance is supplied between the gate and adjacent structures when opening and closing to reduce the risk of entrapment. Swinging gates shall not open into public access areas.
7. The gate must be properly installed and work freely in both directions prior to the installation of the gate operator.
8. Controls intended for user activation must be located at least six feet (6') away from any moving part of the gate and where the user is prevented from reaching over, under, around or through the gate to operate the controls. Outdoor or easily accessible controls shall have a security feature to prevent unauthorized use.
9. The Stop and/or Reset (if provided separately) must be located in the line-of-sight of the gate. Activation of the reset control shall not cause the operator to start.
10. A minimum of two (2) WARNING SIGNS shall be installed, one on each side of the gate where easily visible.
11. For a gate operator utilizing a non-contact sensor:
  - a. Reference owner's manual regarding placement of non-contact sensor for each type of application.
  - b. Care shall be exercised to reduce the risk of nuisance tripping, such as when a vehicle trips the sensor while the gate is still moving.
  - c. One or more non-contact sensors shall be located where the risk of entrapment or obstruction exists, such as the perimeter reachable by a moving gate or barrier.
12. For a gate operator utilizing a contact sensor such as an edge sensor:
  - a. One or more contact sensors shall be located where the risk of entrapment or obstruction exists, such as at the leading edge, trailing edge and post mounted both inside and outside of a vehicular horizontal slide gate.
  - b. One or more contact sensors shall be located at the bottom edge of a vehicular vertical lift gate.
  - c. A hard wired contact sensor shall be located and its wiring arranged so the communication between the sensor and the gate operator is not subject to mechanical damage.
  - d. A wireless contact sensor such as the one that transmits radio frequency (RF) signals to the gate operator for entrapment protection functions shall be located where the transmission of the signals are not obstructed or impeded by building structures, natural landscaping or similar obstruction. A wireless contact sensor shall function under the intended end-use conditions.
  - e. One or more contact sensors shall be located on the inside and outside leading edge of a swing gate. Additionally, if the bottom edge of a swing gate is greater than 6" (152 mm) above the ground at any point in its arc of travel, one or more contact sensors shall be located on the bottom edge.
  - f. One or more contact sensors shall be located at the bottom edge of a vertical barrier (arm).

# OVERVIEW OF TYPICAL INSTALLATION

## **⚠ WARNING**

To prevent SERIOUS INJURY or DEATH; one or more non-contact sensors shall be located where the risk of entrapment or obstruction exists.

### Left-Hand Gate

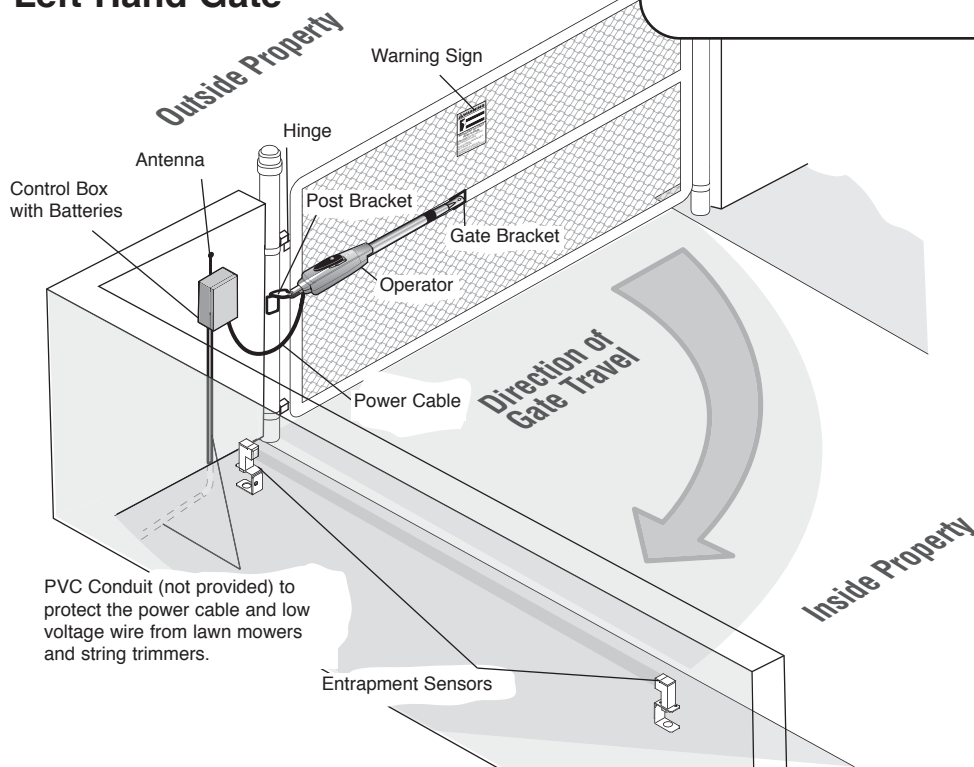

### Right-Hand Gate

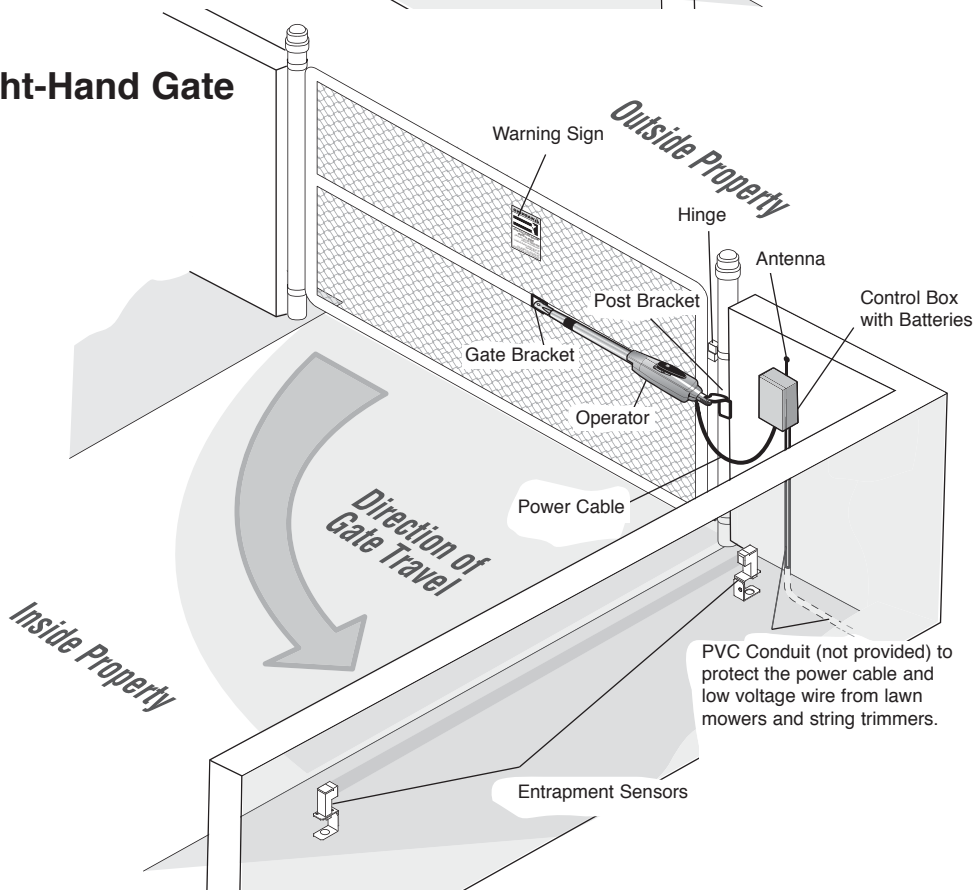

**NOTE:** One or more non-contact sensors shall be located where the risk of entrapment or obstruction exists at either the opening or closing direction. Care shall be exercised to reduce the risk of nuisance tripping, such as when a vehicle, trips the sensor while the gate is still moving.

# Dual Gate Typical Installation

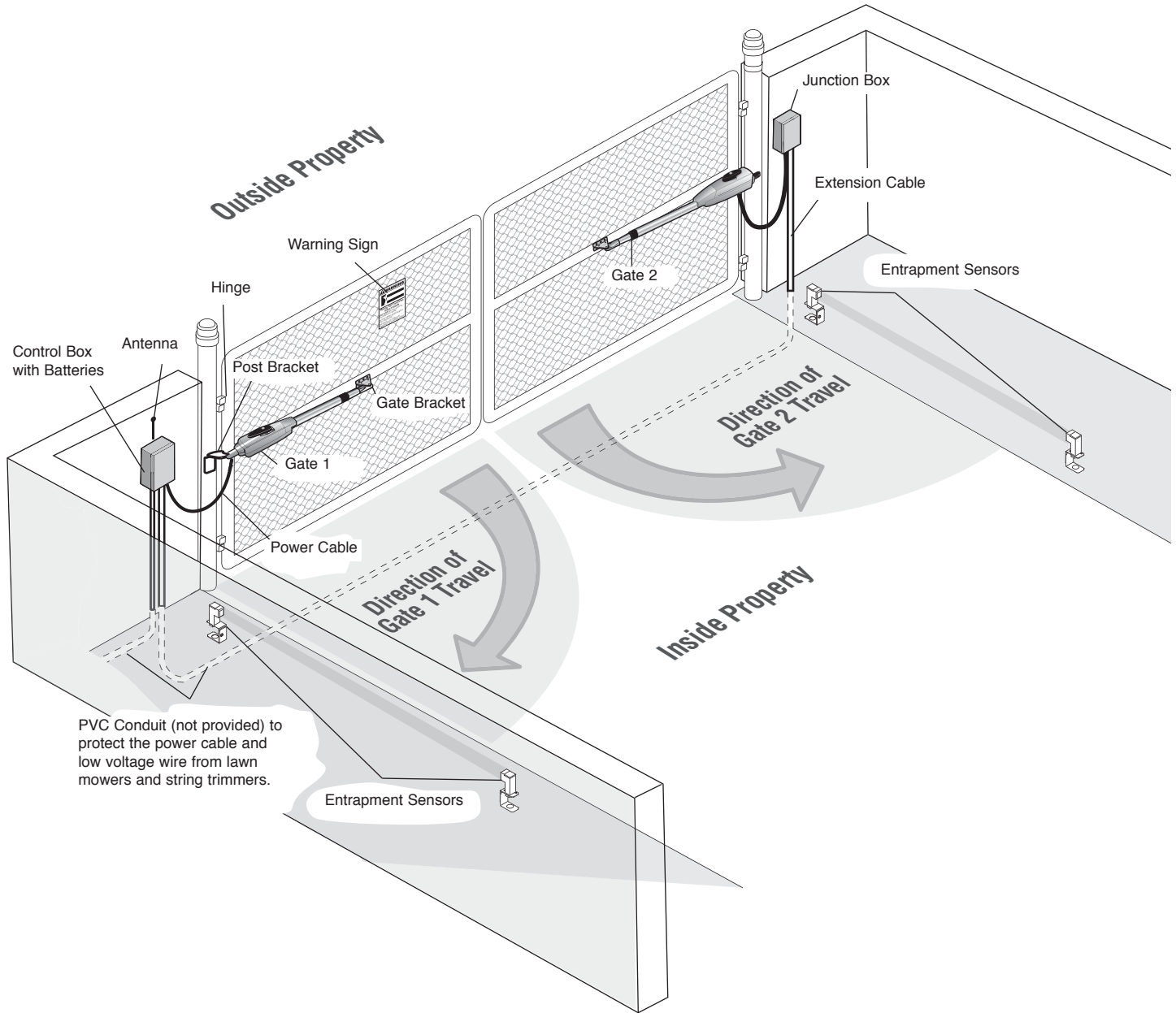

## Safety Precautions for Swing and Ornamental “Grill Type Gates”

### **WARNING**

To prevent **SERIOUS INJURY** or **DEATH** from a moving gate:

- Entrapment protection devices **MUST** be installed to protect anyone who may come near a moving gate.
- Locate entrapment protection devices to protect in **BOTH** the open and close gate cycles.
- Locate entrapment protection devices to protect between moving gate and **RIGID** objects, such as posts.
- A swinging gate shall **NOT** open into public access ways.

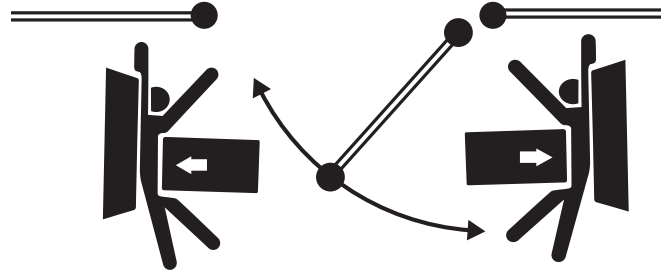

## Warning Sign Placement

### **WARNING**

To prevent **SERIOUS INJURY** or **DEATH** from a moving gate:

- Install warning signs on **EACH** side of gate in **PLAIN VIEW**.
- Permanently secure each warning sign in a suitable manner using fastening holes.

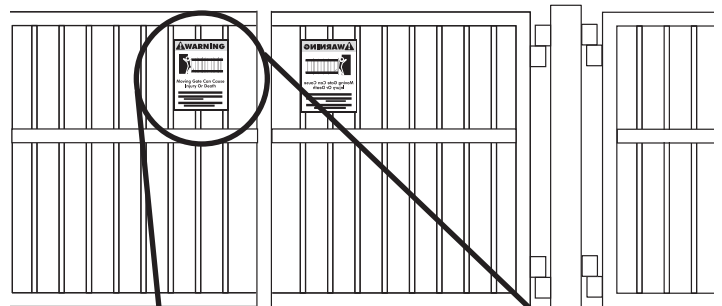

## Before Installation Check Your Gate

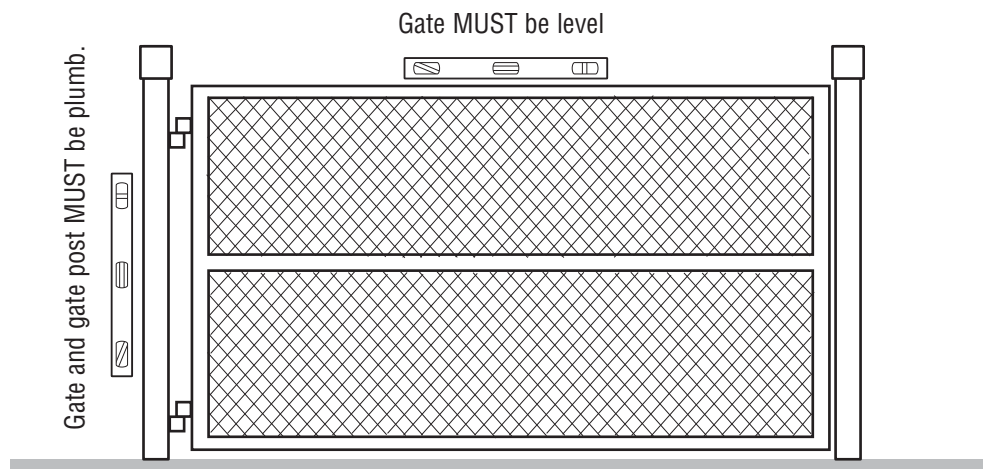

Remove ANY/ALL wheels from the bottom of the gate

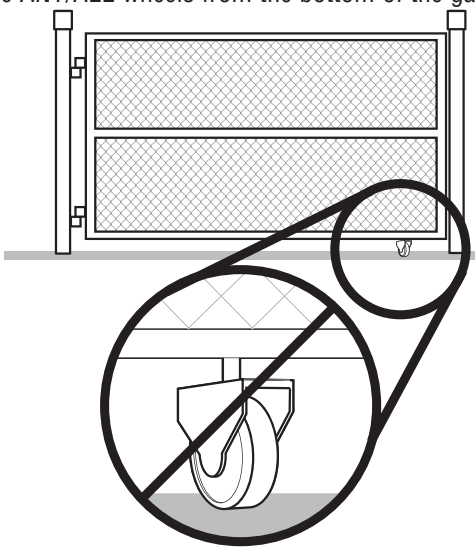

Gate MUST NOT hit or drag across ground

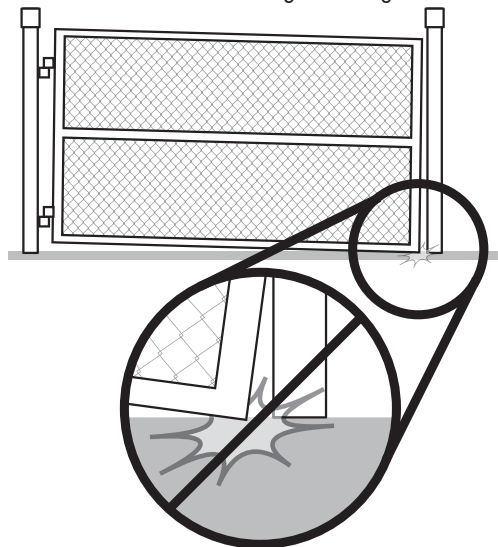

Gate MUST swing freely and be supported entirely by its hinges. Heavy duty, ball bearing type hinges are recommended.

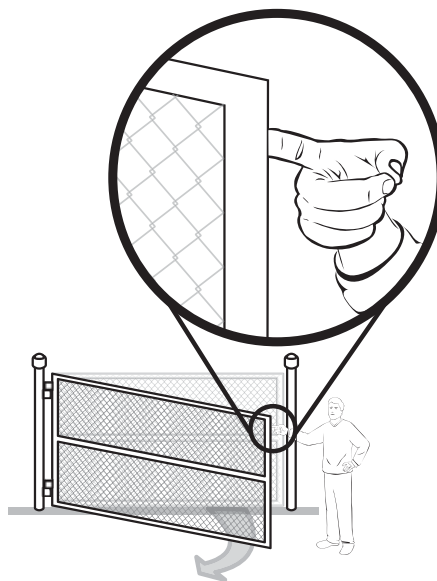

# Mounting Options

Mounting locations vary depending on type and style of your gate. Minimum distance from the ground should not be less than 4" from the bottom of the gate operator arm.

Recommended:

- = Gate post bracket mounting locations
- = Gate bracket mount locations

Optional:

- = Gate post bracket mounting locations
- = Gate bracket mount locations

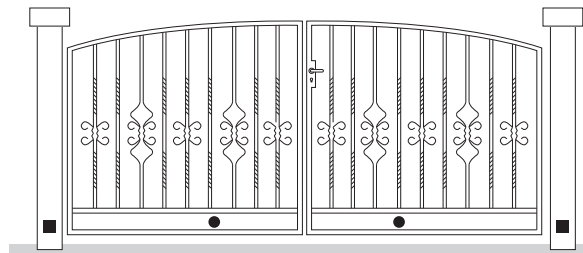
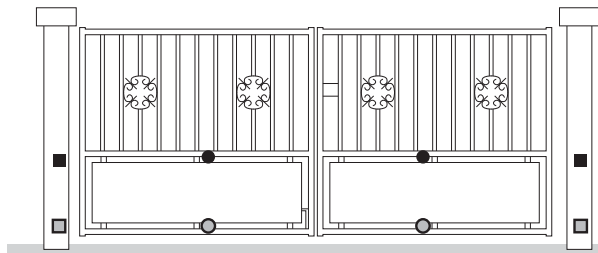
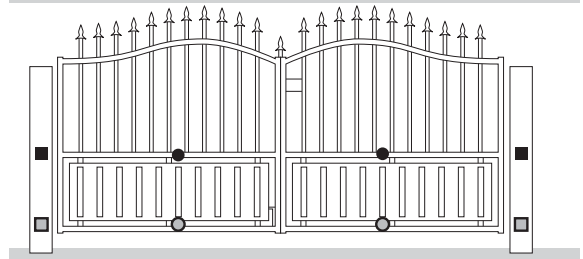
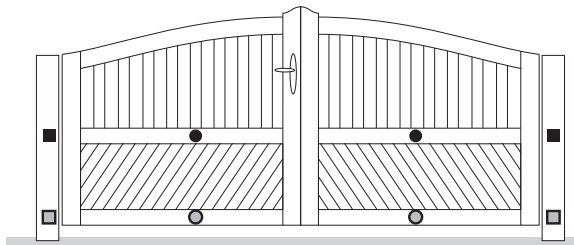
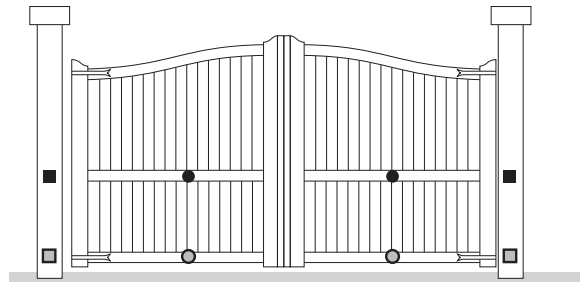
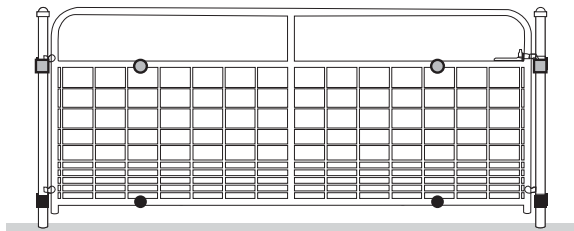
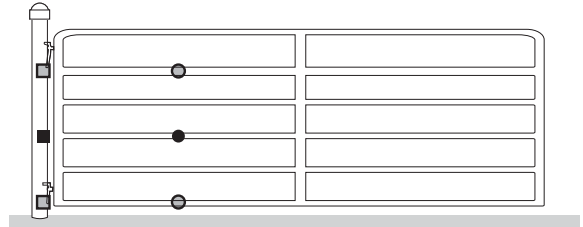
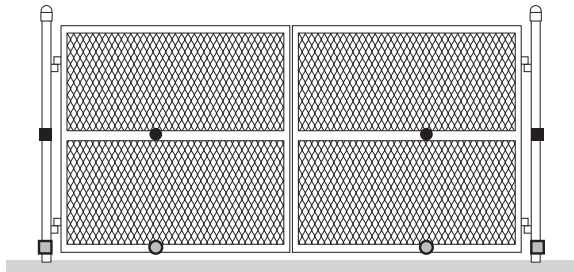



# INSTALLATION

## Step 1: Manual Release

Insert the key into the lock and turn counter-clockwise 180°. Turn the release lever counter-clockwise 180°. The operator is in manual mode.

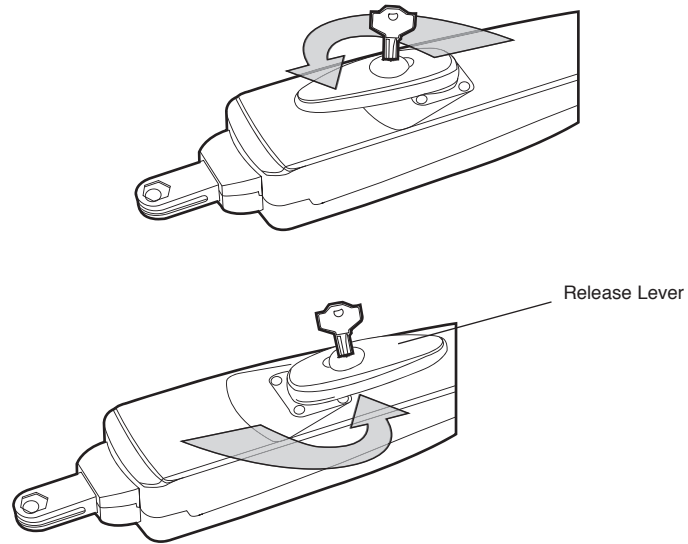

## Step 2A: Determine Position of the Pull-to-Open Bracket

The Pull-To-Open bracket can be assembled to work on a **Left-Hand** or a **Right-Hand** gate. Review the gate types below and select the type of installation you will require.

**NOTE:** If the **Pull-To-Open** bracket is not assembled correctly you will damage the operator.

### Left-Hand Gate

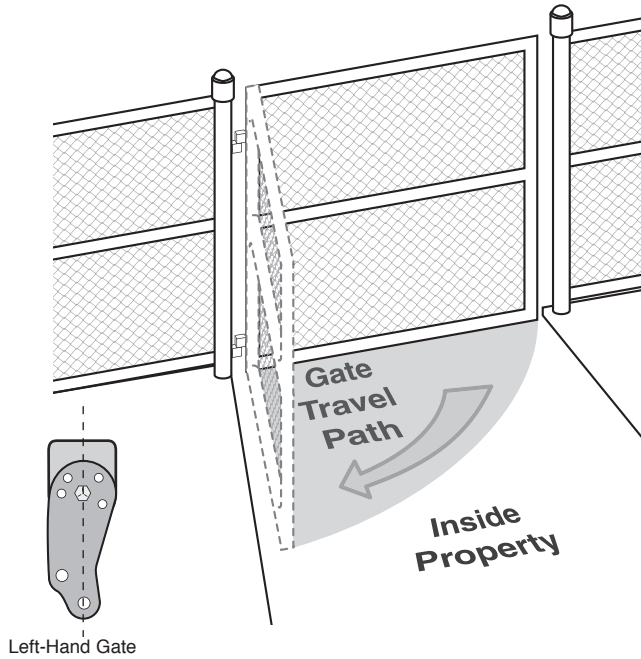

### Right-Hand Gate

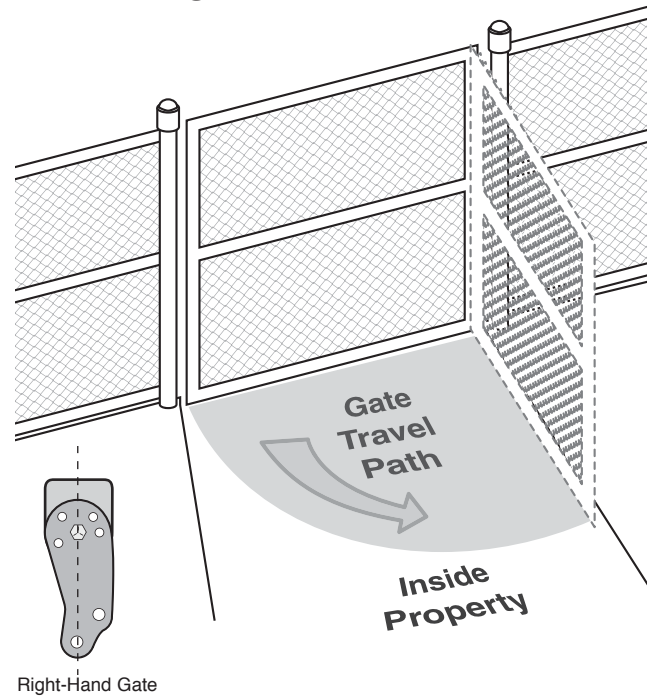

## Step 2B: Determine Position of the "Optional" Push-to-Open Bracket (Not provided. See Accessories.)

The Push-To-Open bracket can be assembled to work on a **Left-Hand** or a **Right-Hand** gate. Review the gate types below and select the type of installation you will require.

### Left-Hand Gate

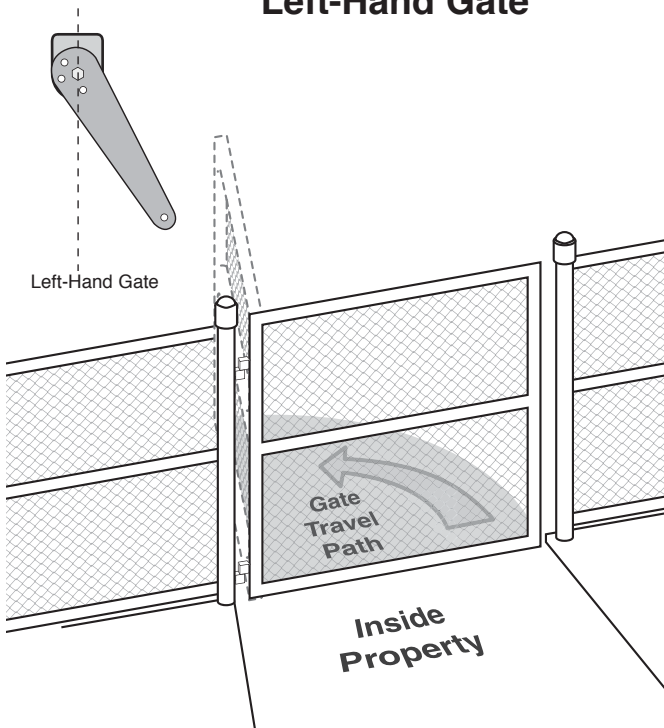

### Right-Hand Gate

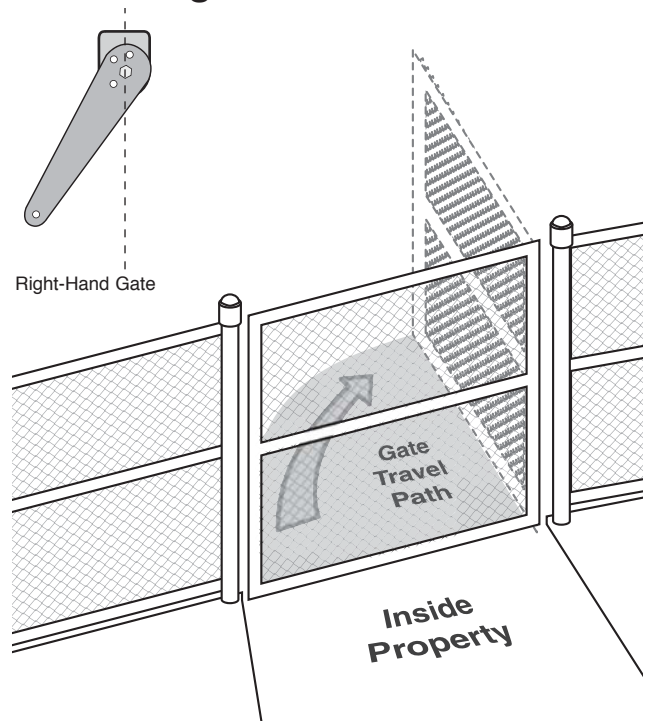

### Step 3: Determine Mounting Location

The gate post bracket assembly can be mounted several places on the gate post. Refer to the illustrations on page 10 for the ideal mounting location.

Refer to the illustrations below to determine the appropriate dimensions for the Pull-To-Open bracket.

**NOTE:** It may be necessary to add shims (angle iron, sheets of metal or wood) to the gate post to achieve the required dimensions.

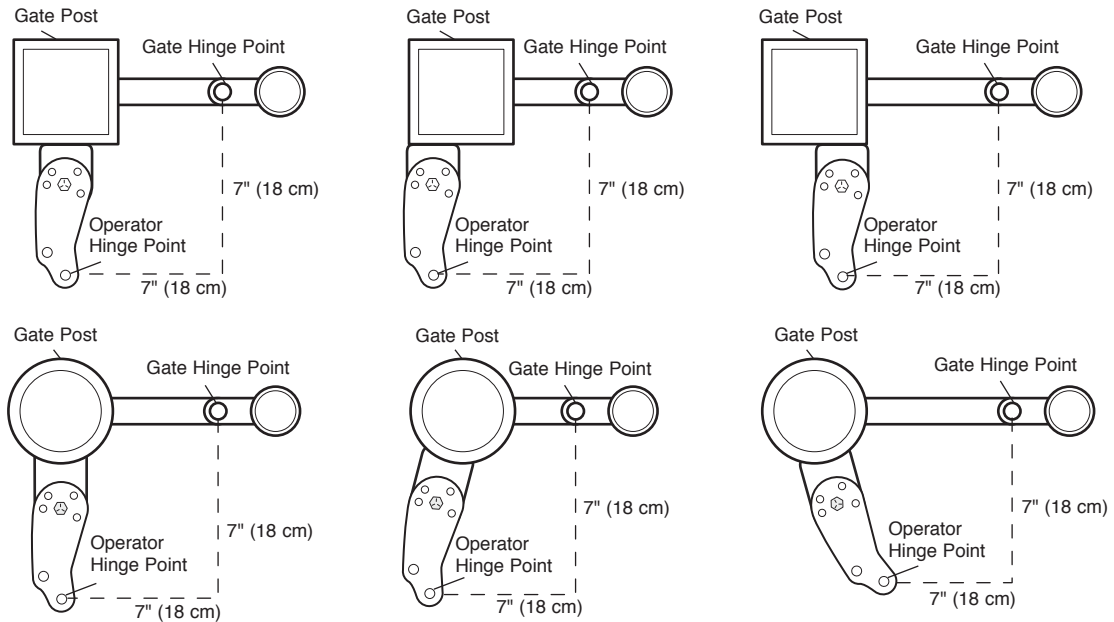

### Step 4: Assemble Gate Post Bracket (Pull-to-Open)

Assemble Gate Post bracket by placing Pull-To-Open bracket on top of Post bracket. Insert bolt through both brackets and secure with washer, lock washer and nut. Insert second bolt through both brackets and secure with washer, lock washer and nut.

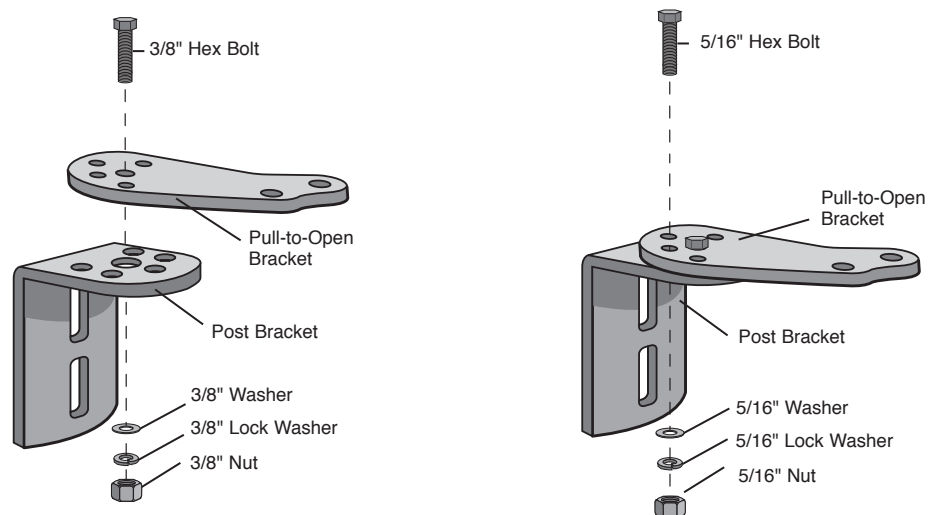

**NOTE:** All the illustrations on the following pages display a typical **Left-Hand** Gate installation.

## Step 5: Attach Brackets to Arm

Attach gate post bracket to arm using hex bolt and lock nut with nylon insert. Attach gate bracket to arm using pin and hairpin clip.

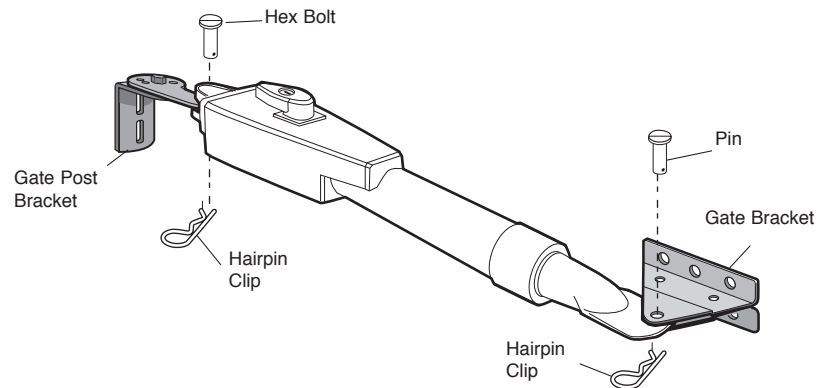

## Step 6: Position Operator on Gate

The gate post bracket assembly can be mounted several places on the gate post. Refer to the illustrations on page 10 for mounting options.

Place opener arm against gate post at the desired vertical position and temporarily secure Gate Post bracket with C-clamp. **Arm must be level.**

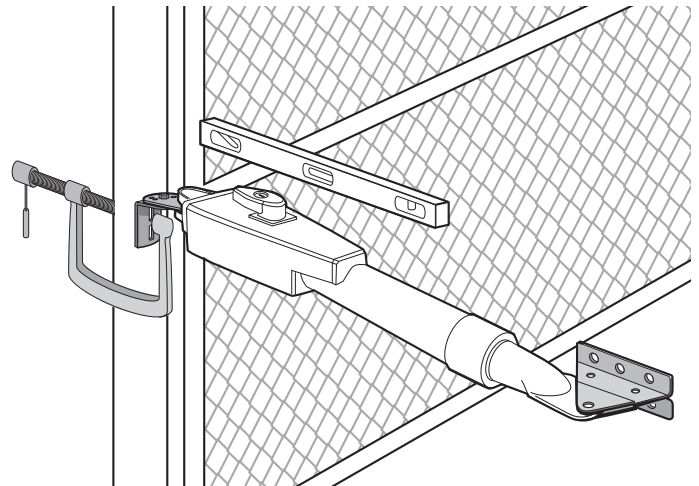
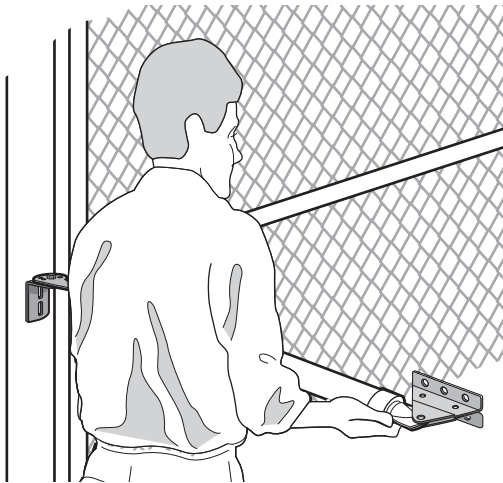

Open gate to desired **open** position (no greater than 100°) and hold arm against gate. Mark mounting holes on gate for reference.

Temporarily secure the gate bracket using a C-clamp.

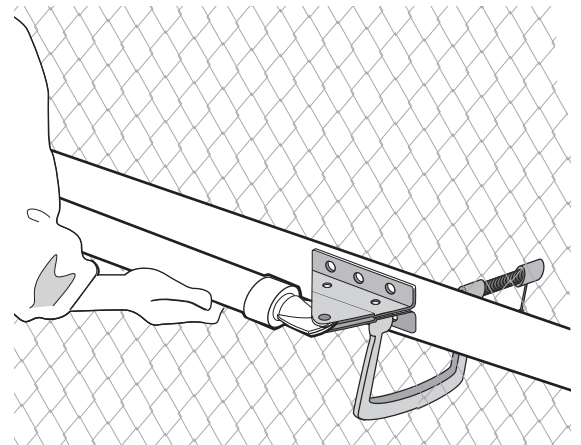
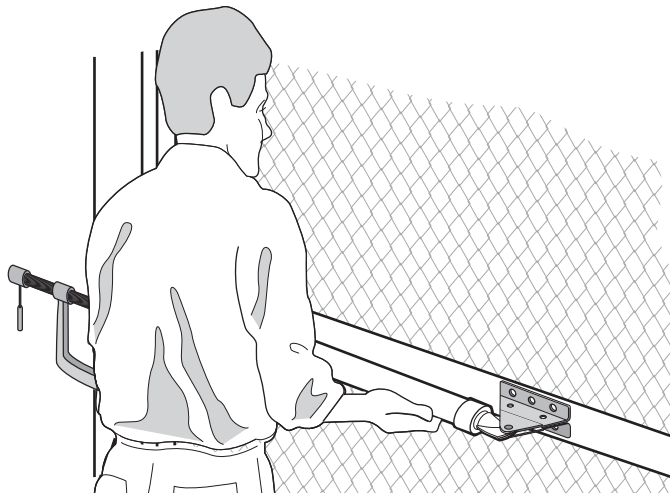

## Step 7: Test Gate Travel

Manually open and close the gate.

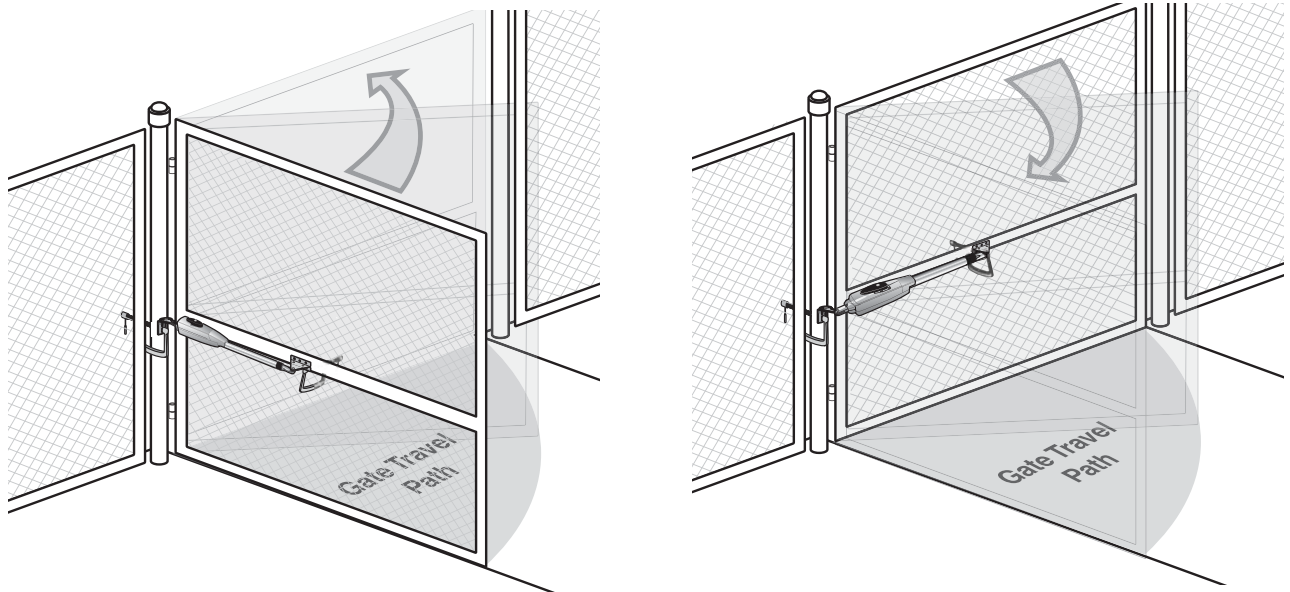

Ensure that the arm does not bind against the pull-to-open bracket.

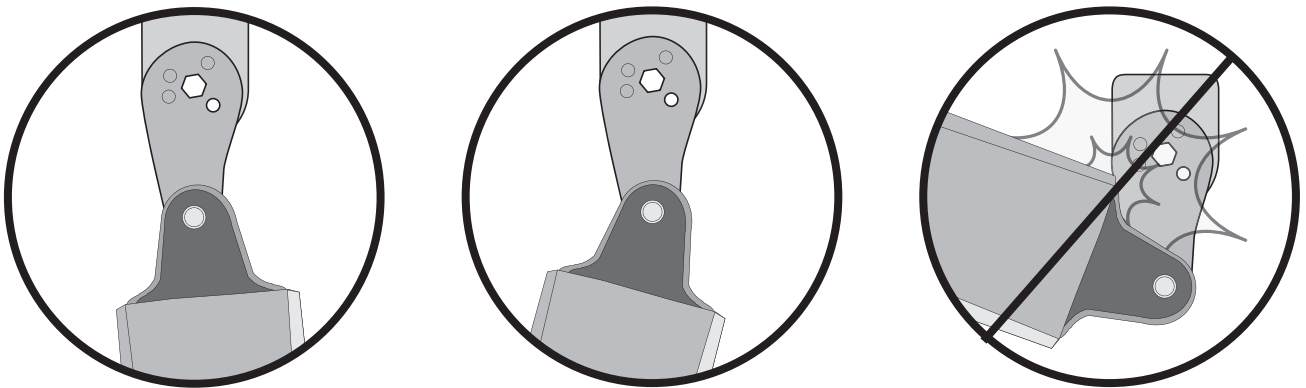

Ensure that the piston does not bottom out.

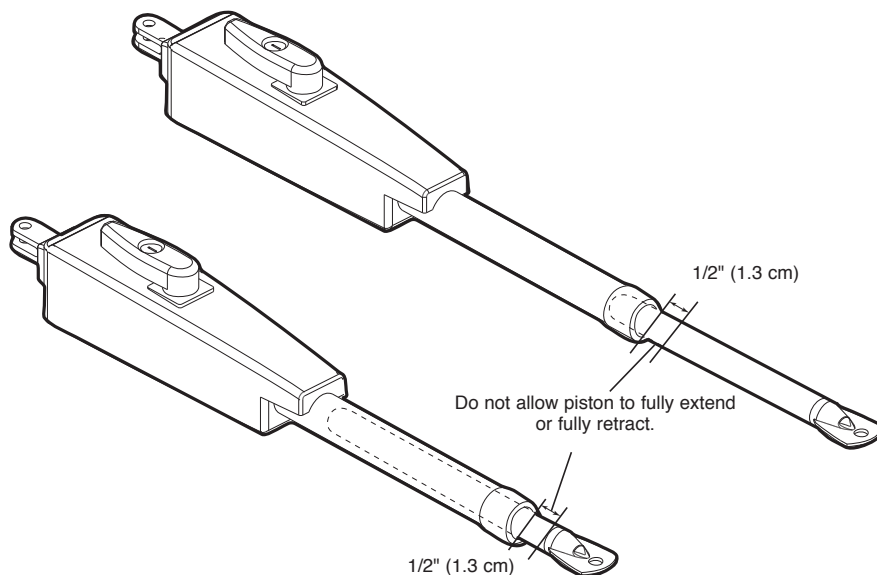

**NOTE:** If gate does not open and close completely adjust the position of the gate bracket and mark new mounting holes.



## Step 8: Secure Gate Post Bracket to Gate Post

Mark holes for gate post bracket.

Remove C-clamp and operator. Set aside and drill adequate holes in gate post.

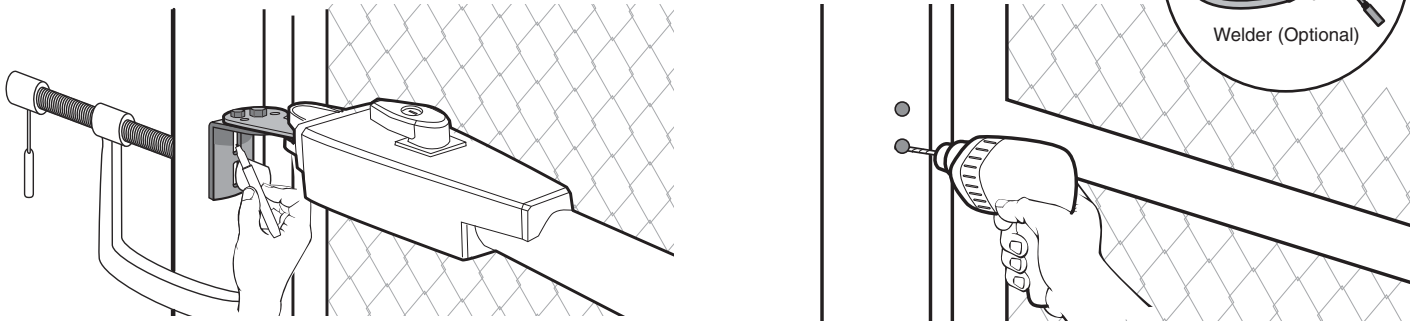

Secure gate post bracket to gate post using hardware. Keep arm level.

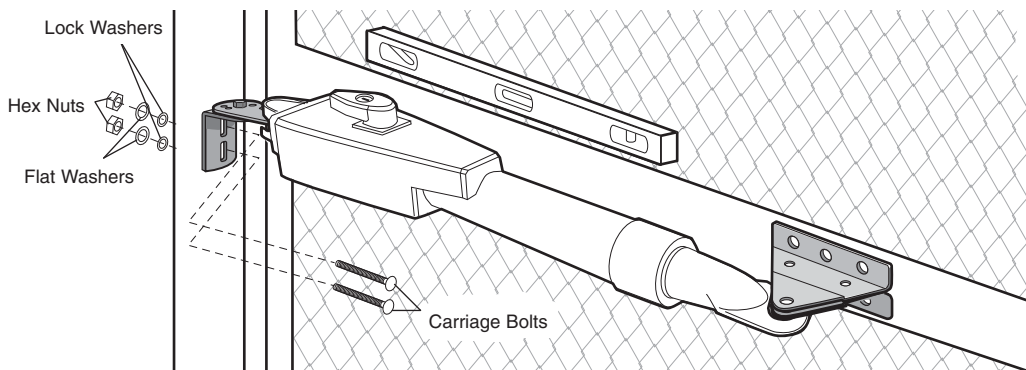

## Step 9: Secure Gate Bracket to Gate

Drill holes in gate or reinforcement (if necessary) large enough for the gate bracket mounting hardware. Secure gate bracket to gate using hardware (not provided). Keep arm level.

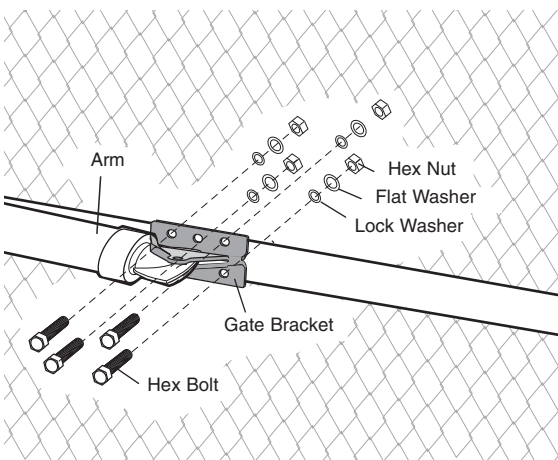

**NOTE:** Some installations may require additional reinforcement be installed on the gate.

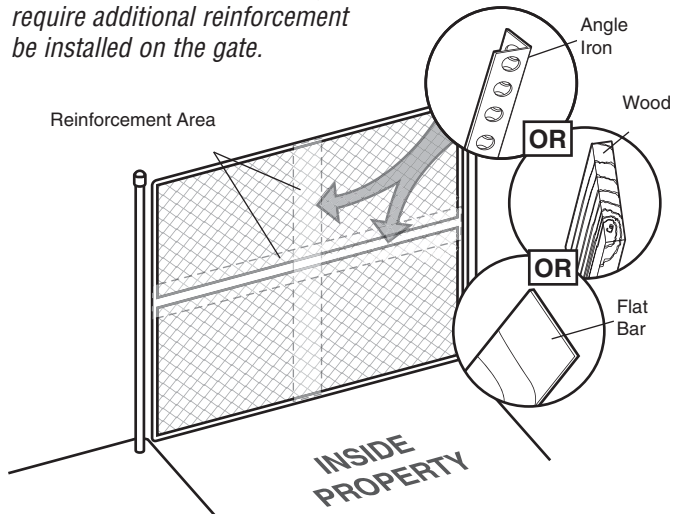

Manually move the gate to verify gate opens and closes fully.



## Step 10: Warning Sign Placement

Warning placards **MUST** be installed on both sides of the gate and in plain view.

### **WARNING**

To prevent **SERIOUS INJURY** or **DEATH** from a moving gate:

- Install warning signs on the front and back of the gate in **PLAIN VIEW**.
- Permanently secure each warning sign in a suitable manner using fastening holes.

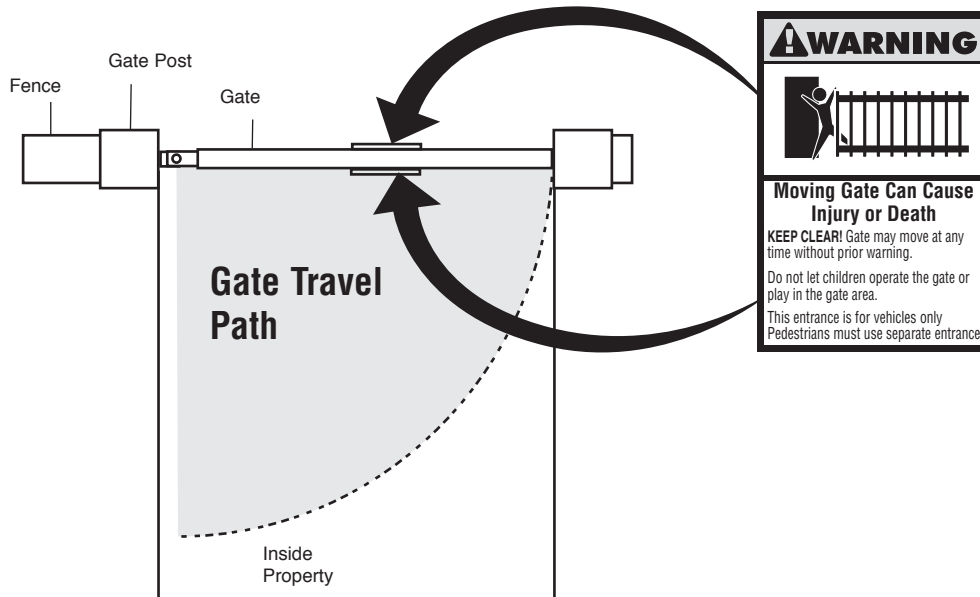

If you are installing a 2nd operator repeat installation steps 1-10 for the second gate before proceeding to the next page.

**NOTE:** It is recommended that the control box be mounted within 3' (.9 m) of Gate 1 or Gate 2.

## Step 11: Open the Control Box

Remove screws and open the control box.

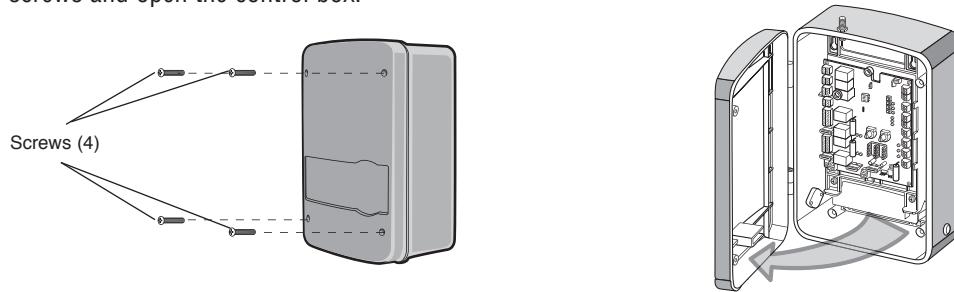

## Step 12: Select Mounting Holes

Select holes to be used for mounting and knock out using a screwdriver and hammer.

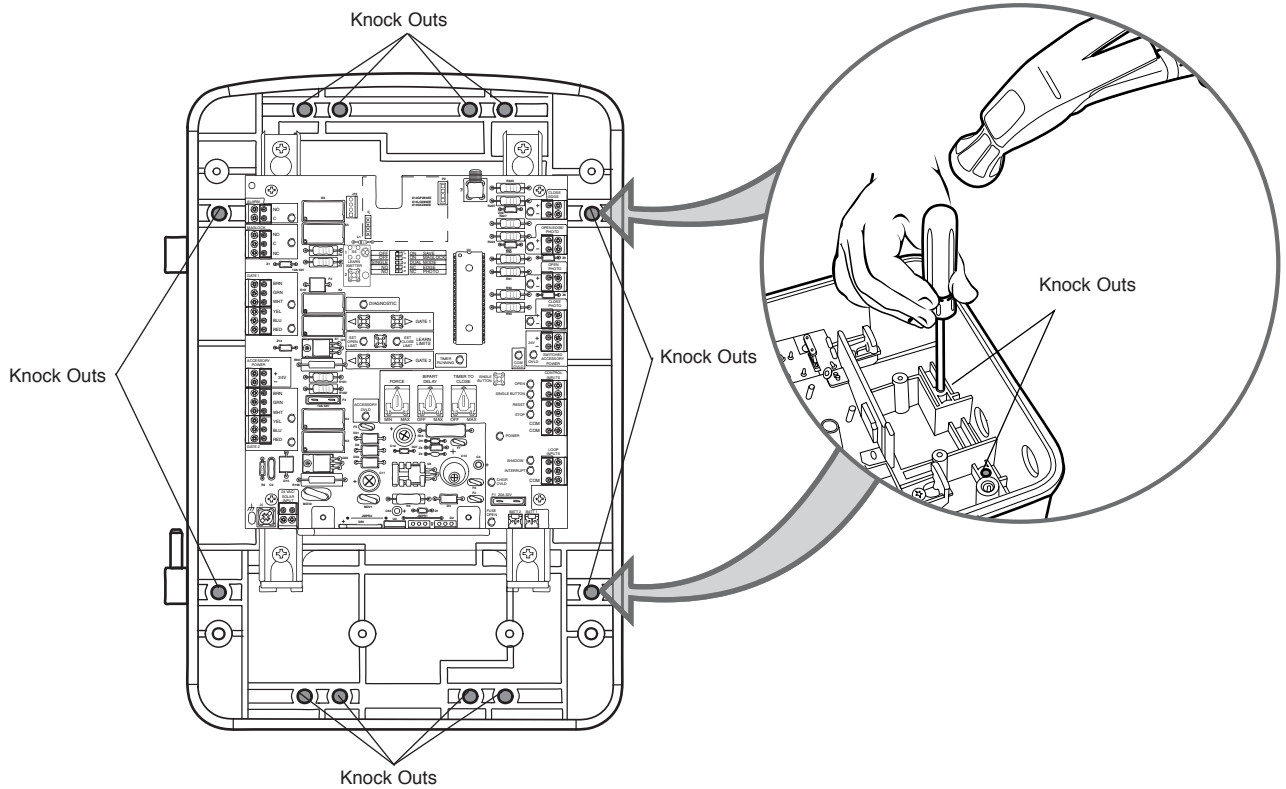

## Step 13: Mount Control Box

Secure control box to mounting surface (post, wall, column, etc.) using appropriate hardware.

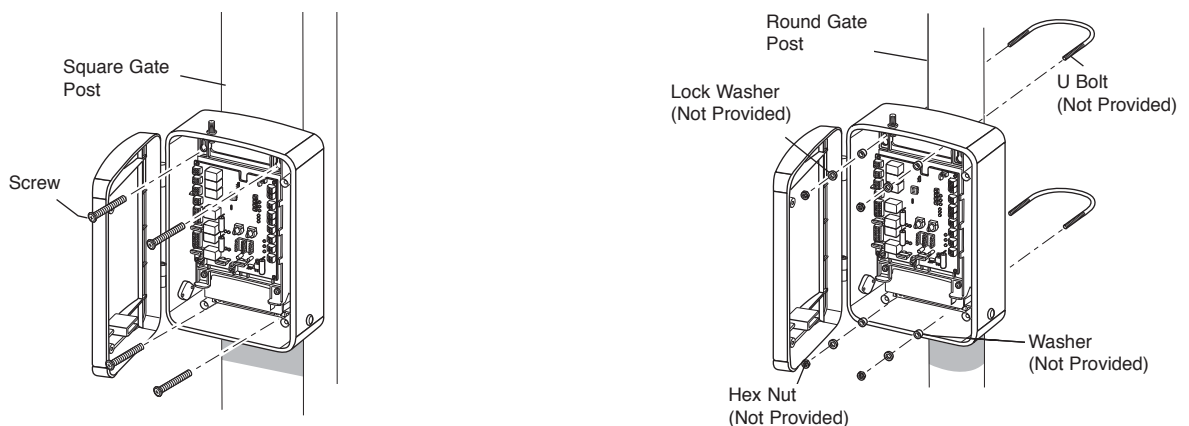

# MOTOR WIRING

## **WARNING**

To reduce the risk of SEVERE INJURY or DEATH:

- ANY maintenance to the operator or in the area near the operator **MUST** not be performed until disconnecting the electrical power and locking-out the power via the operator power switch. Upon completion of maintenance the area **MUST** be cleared and secured, at that time the unit may be returned to service.
- Disconnect power at the fuse box **BEFORE** proceeding. Operator **MUST** be properly grounded and connected in accordance with local electrical codes. **NOTE:** *The operator should be on a separate fused line of adequate capacity.*
- ALL electrical connections **MUST** be made by a qualified individual.
- **DO NOT** install ANY wiring or attempt to run the operator without consulting the wiring diagram. We recommend that you install an optional reversing edge **BEFORE** proceeding with the control station installation.
- ALL power wiring should be on a dedicated circuit and well protected. The location of the power disconnect should be visible and clearly labeled.
- ALL power and control wiring **MUST** be run in separate conduit.
- **BEFORE** installing power wiring or control stations be sure to follow ALL specifications and warnings described below. Failure to do so may result in SEVERE INJURY to persons and/or damage to operator.

### Step 1: Watertight Connector Nut

Insert operator cable through watertight connector nut.

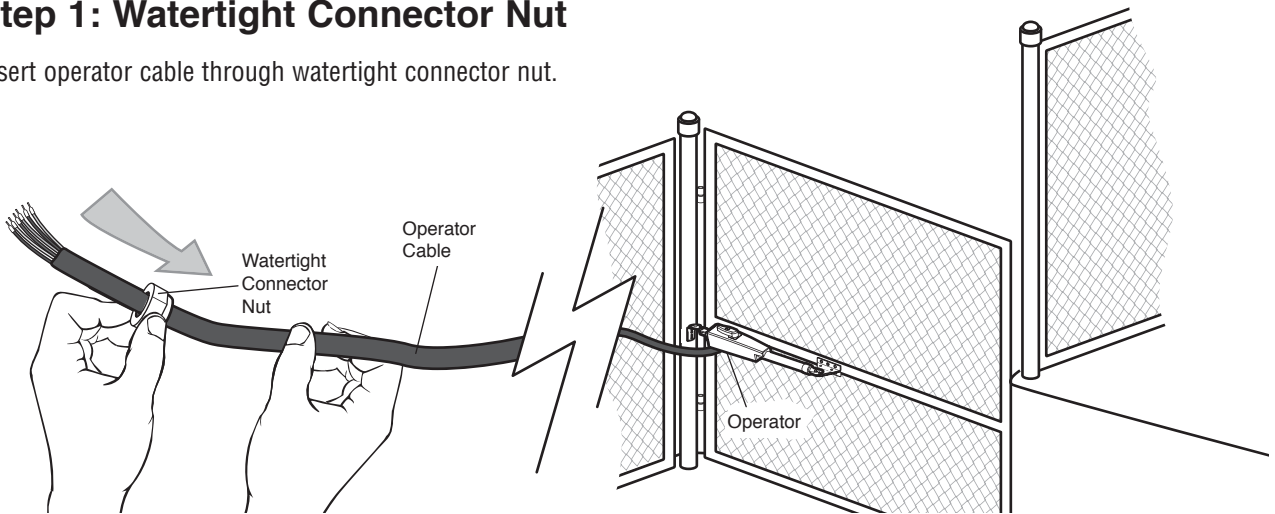

### Step 2: Insert Operator Cable

Insert operator cable through watertight connector mounted in the bottom of the control box.

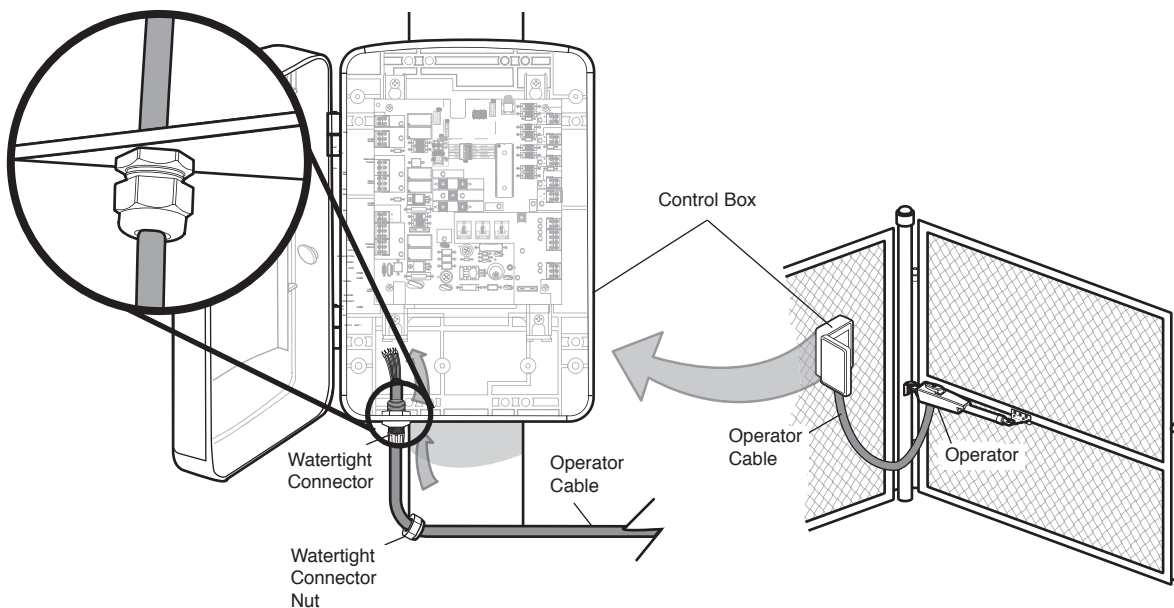

### Step 3: Connect Operator to Control Board

Extend cable and wires to "Gate 1" connector for single gate arm installation and connect as shown. Repeat for "Gate 2" connector and connect as shown.

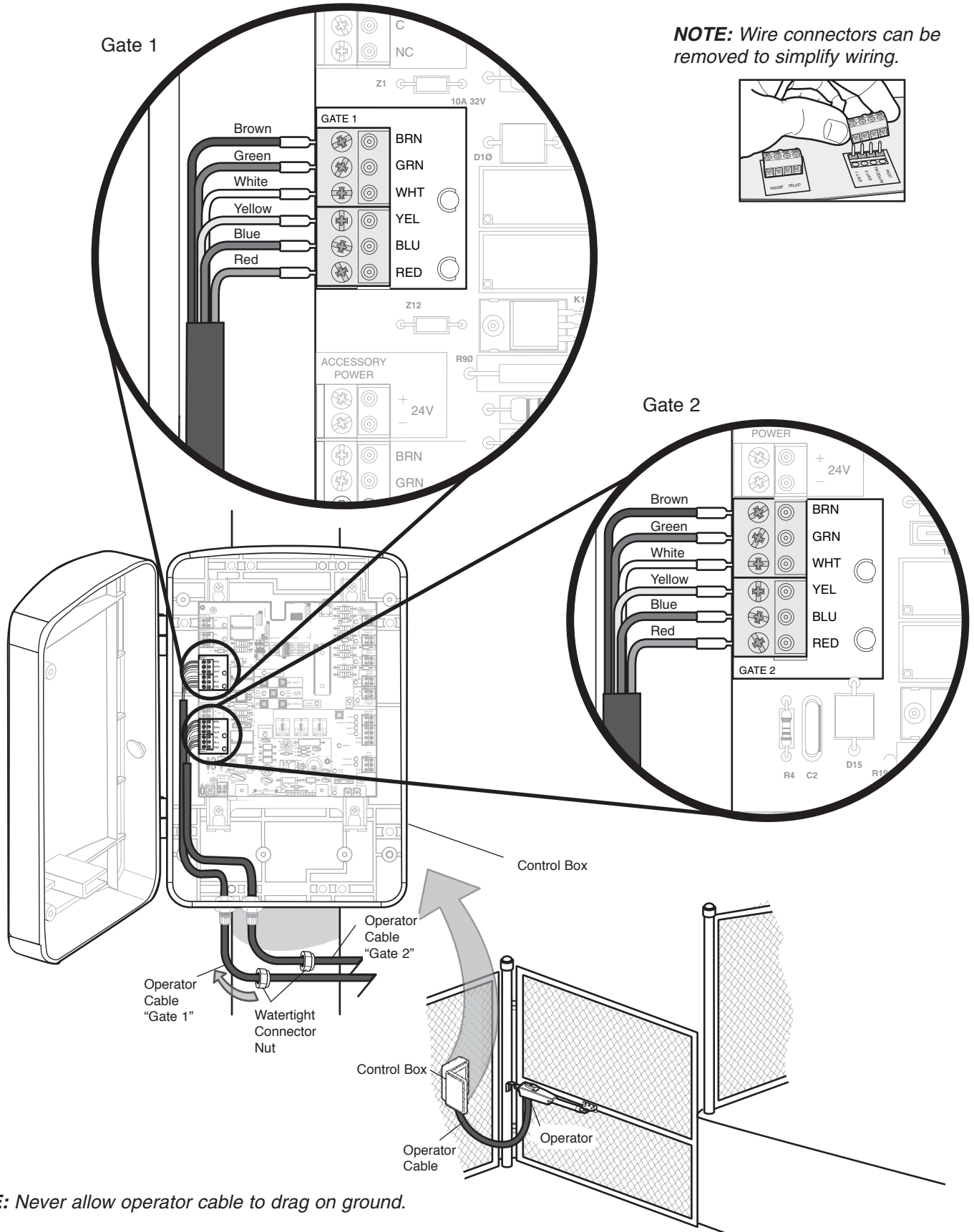

# POWER WIRING

## CAUTION

To AVOID damaging plug-in transformer, it MUST be enclosed in a suitable weatherproof enclosure and provided with proper weatherproof fixtures.

## CAUTION

To AVOID damaging gas, power or other underground utility lines, contact underground utility locating companies BEFORE digging.

### Connect Transformer to Control Board

**NOTE:** All power wiring should be on a dedicated circuit and well protected.

Calculated using NEC guidelines. Local codes and conditions must be reviewed for suitability of wire installation.

The transformer can be plugged into a receptacle external to the control box. Run low voltage wire between the transformer and control box. This will create more space in the control box for accessories.

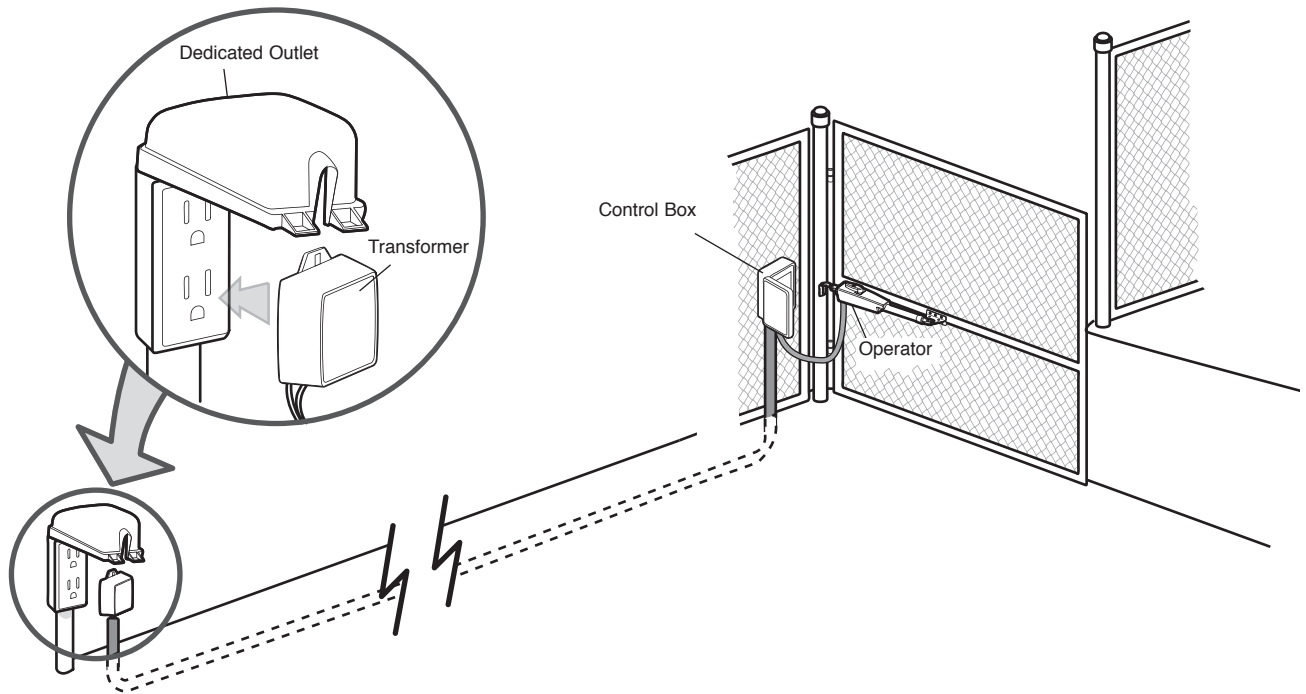

OR

Connect 120Vac directly to the box and plug the transformer to the receptacle inside the control box.

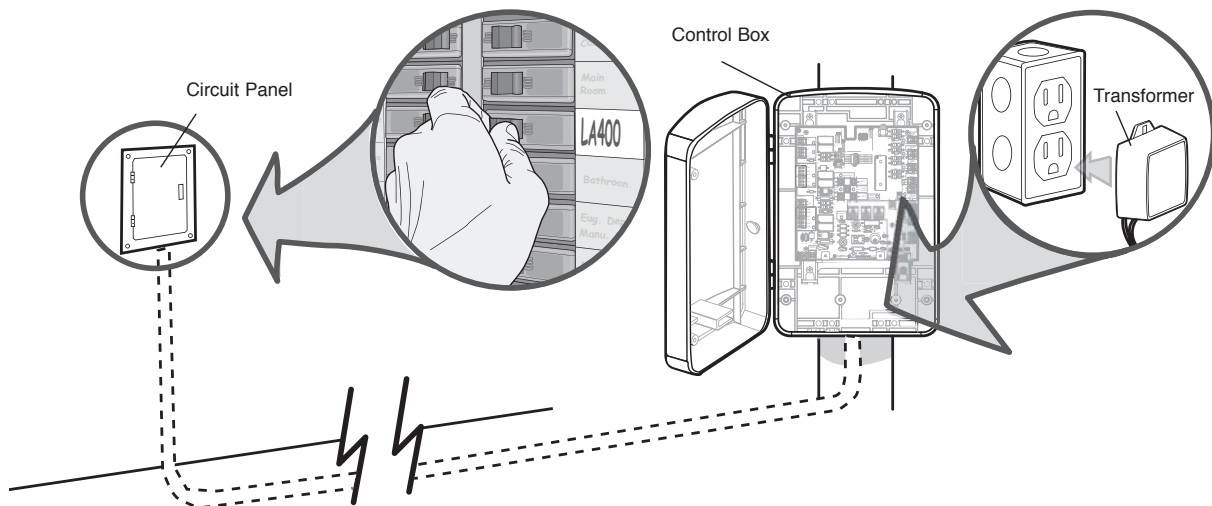

## EARTH GROUND ROD INSTALLATION (OPTIONAL)

**NOTE:** For proper operation, do not connect the earth ground rod to the green screw on the outlet plate.

1. Install earth ground rod within 3' (0.9 m) of the operator.
2. Disconnect and remove the green/yellow ground wire connected to the screw terminal of the control board.
3. Attach earth ground rod wire to the screw terminal of the control board marked **J4**. Ensure the power wiring ground connection remains securely connected to the green screw on the outlet plate.

## CAUTION

To AVOID damaging gas, power or other underground utility lines, contact underground utility locating companies BEFORE digging.

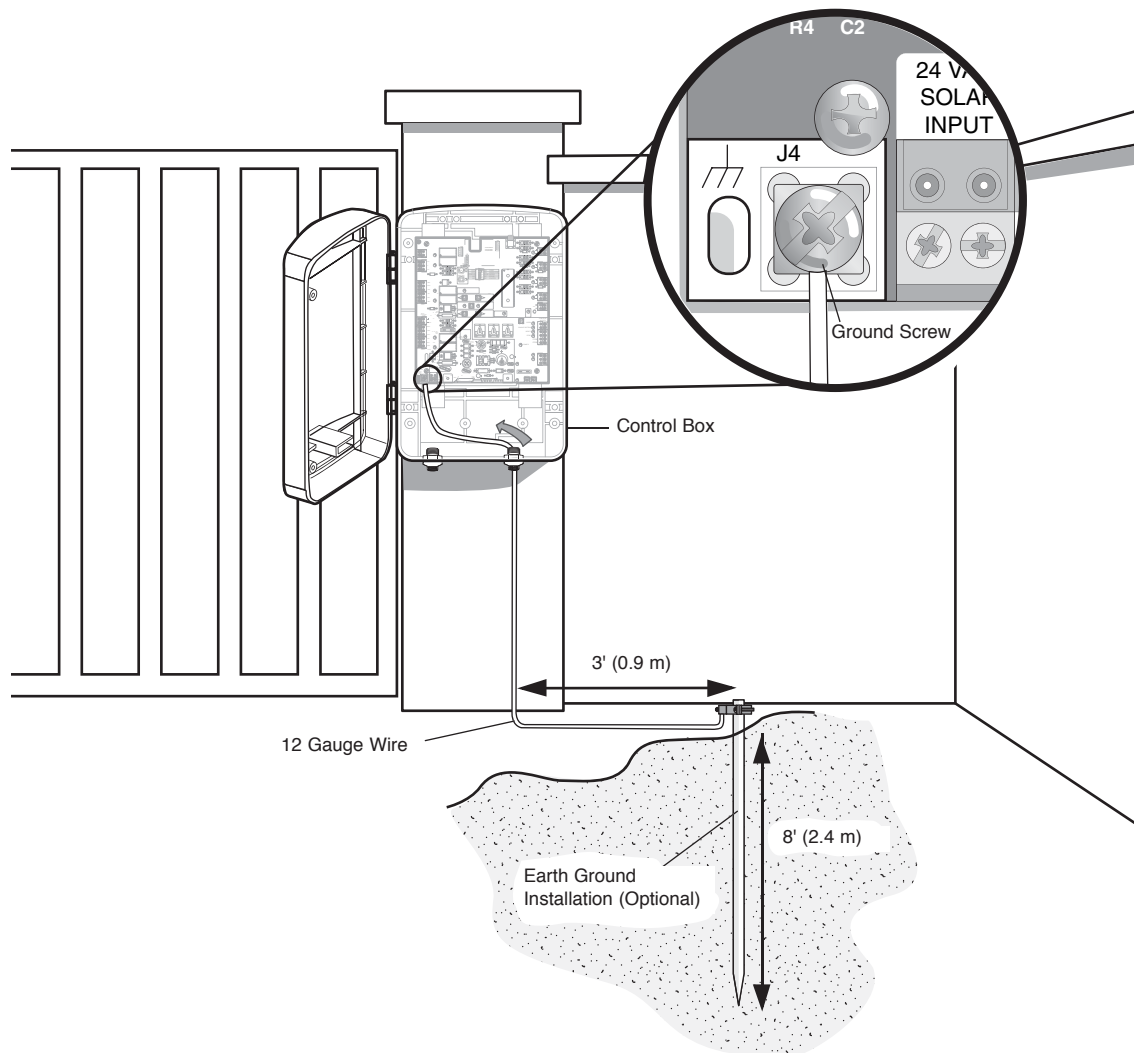



# CONTROL WIRING

## CAUTION

To reduce the risk of FIRE or INJURY to persons use ONLY LiftMaster part #K74-30762 for replacement batteries.

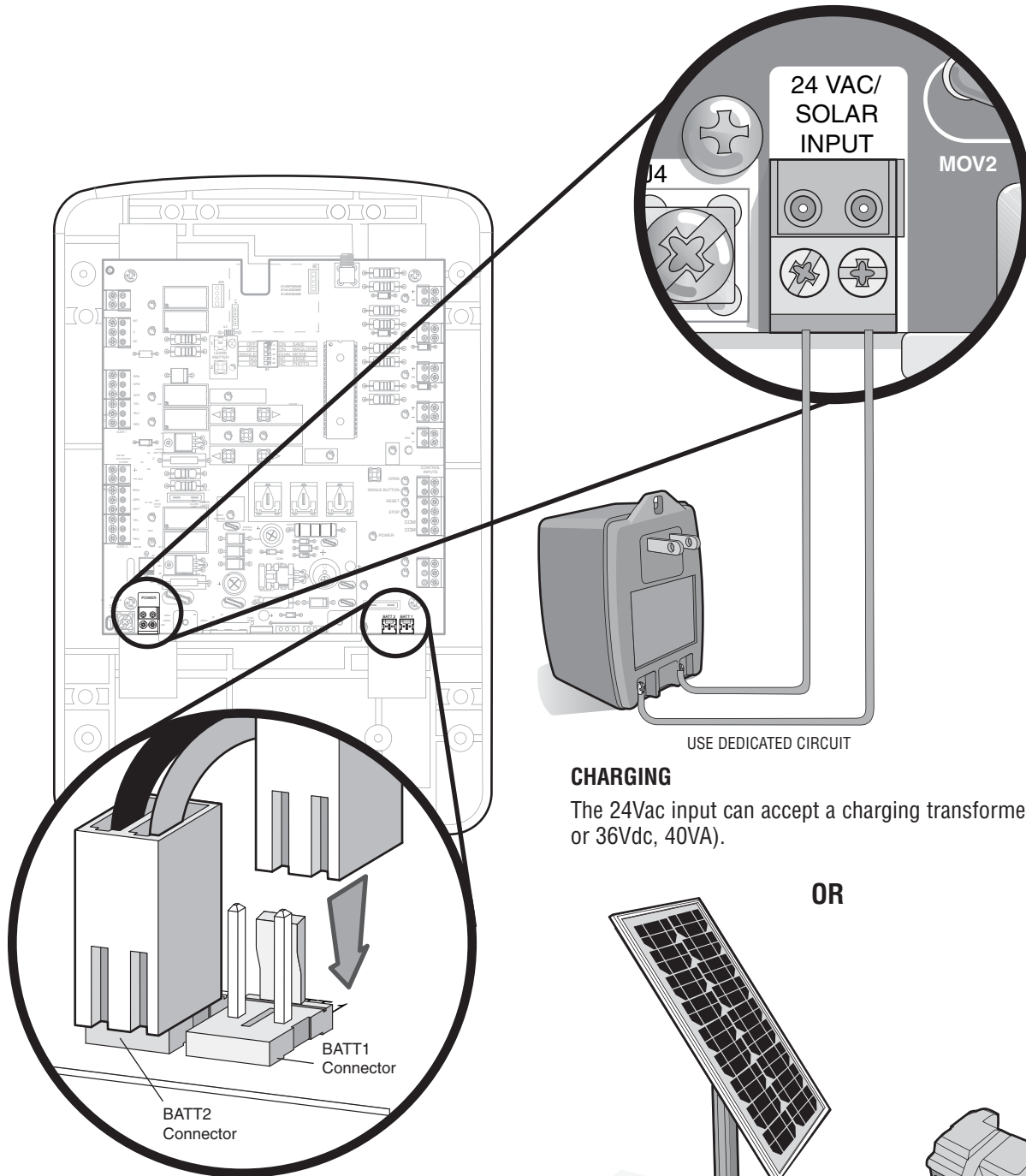

### CHARGING

The 24Vac input can accept a charging transformer (26Vac, 29VA or 36Vdc, 40VA).

OR

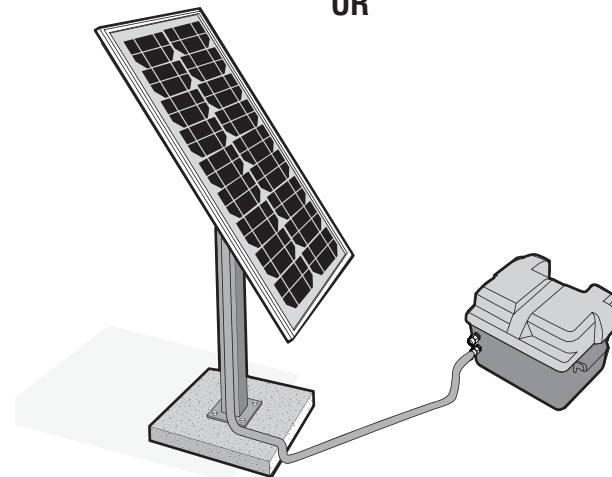

### SOLAR PANEL KIT

Optional Liftmaster solar panel(s) kit may be used to charge the batteries. (See Accessories)

### BATTERY

The main source of power for the operator is the batteries. The batteries can be charged in circuit by using a charging transformer or solar panels.

# ADJUSTING / RUNNING THE OPERATOR

## Step 1: Set Dip Switch

1. The Save switch must be set to the OFF position prior to programming or changing the switches.
2. Set switch to Single for single gate installation. For Dual (Gate 1 and 2) installation set switch on Dual.

**NOTE:** Save switch must be in the OFF position prior to programming or changing switches for the change to be saved.

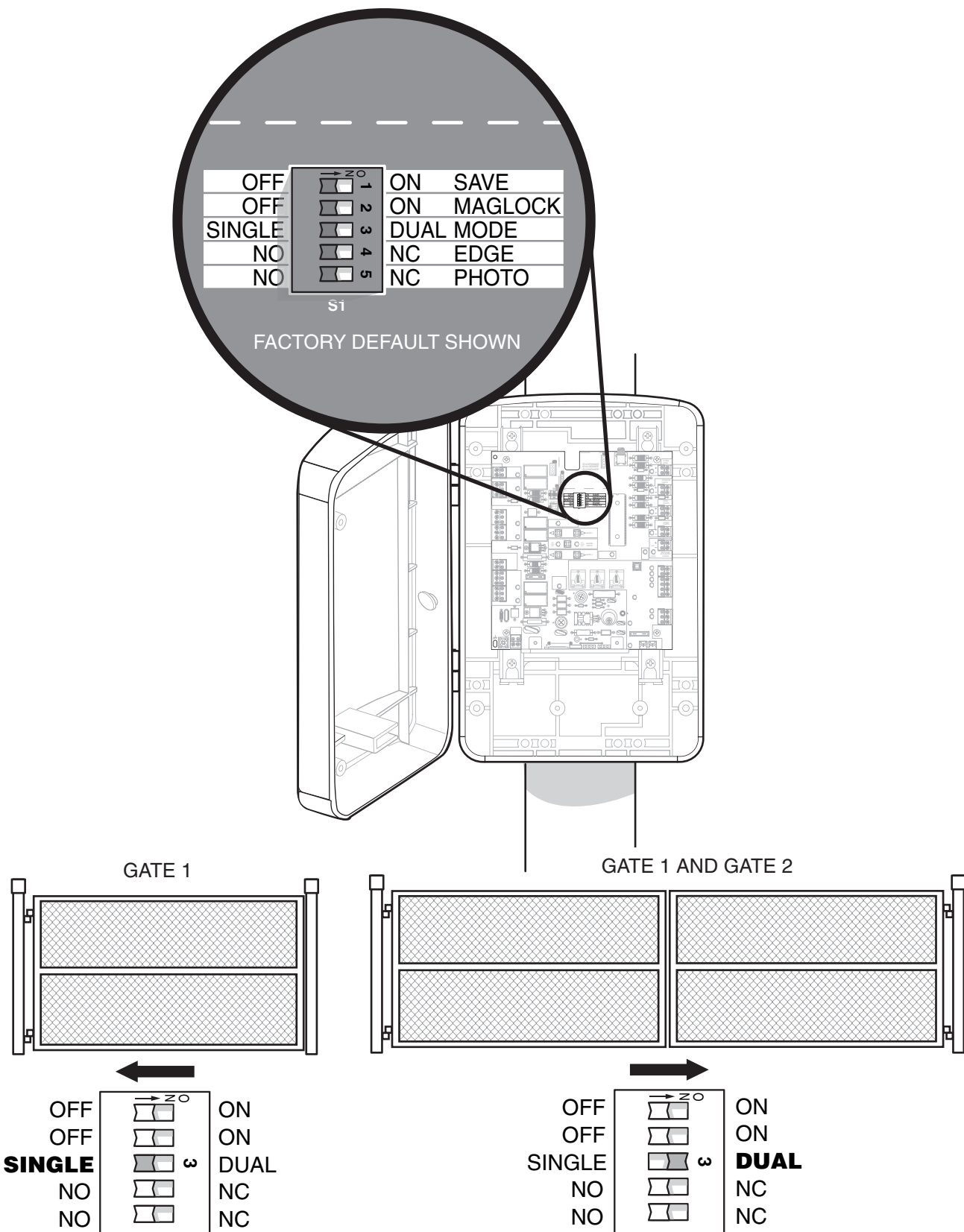

## Step 2: Program Limits (Ensure Save Switch is in the OFF position before beginning)

1. With the gate in the closed position, press the “LEARN LIMITS” button. The “SET OPEN LIMIT” LED will blink.

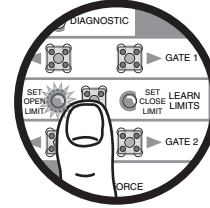

2. Use the “Gate 1” buttons to move Gate 1 to the desired open position (not to exceed 100°). If you have gone beyond the desired open position you can jog the gate towards the close position by using the opposite Gate 1 button. Repeat if Gate 2 is present using the “Gate 2” buttons.

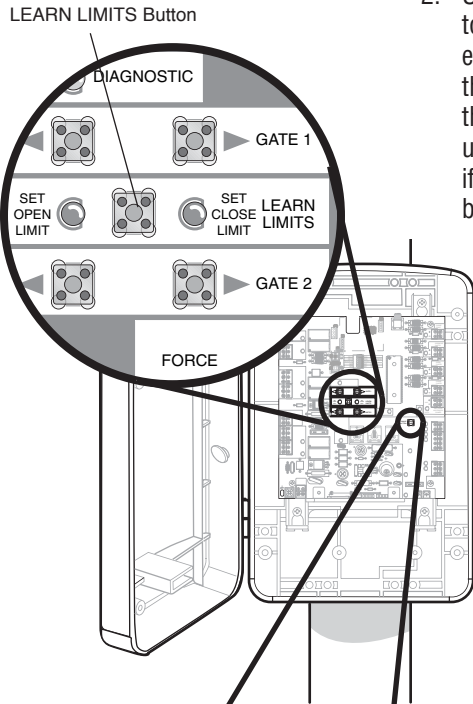
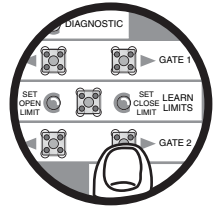
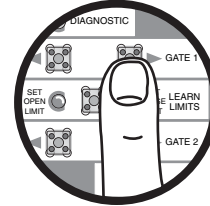

3. Press the “LEARN LIMITS” button again to set the Open position. The “SET CLOSE LIMIT” LED will blink and beep once.

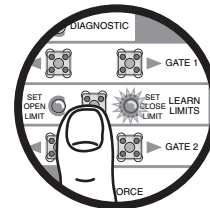

4. Use the “Gate 1” buttons to move Gate 1 to the desired close position. If you have gone beyond the desired close position you can jog the gate towards the open position by using the opposite Gate 1 button. Repeat if Gate 2 is present using the “Gate 2” buttons.

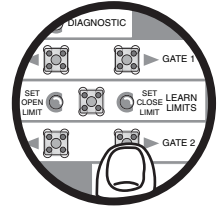
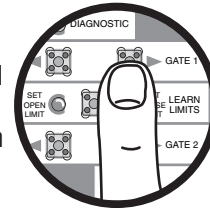

5. Press the “LEARN LIMITS” button again to set the Closed position. The “SET CLOSE LIMIT” LED will blink and beep. The limits are now set.

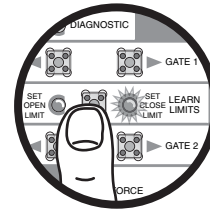

6. Using the single button control on the board, run the gate(s) from the closed position to the open position. This will learn the forces.

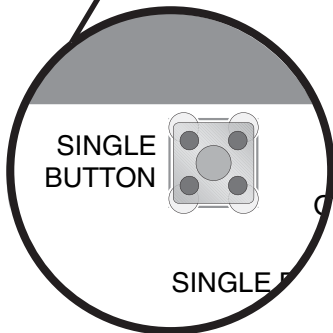

7. Set Save Switch to the ON position.

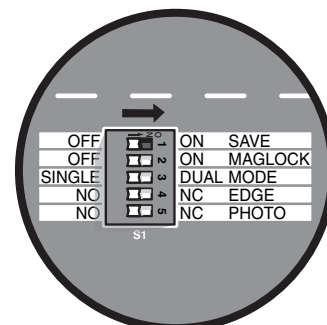

### Step 3: Set Force / Bi-Part / Timer

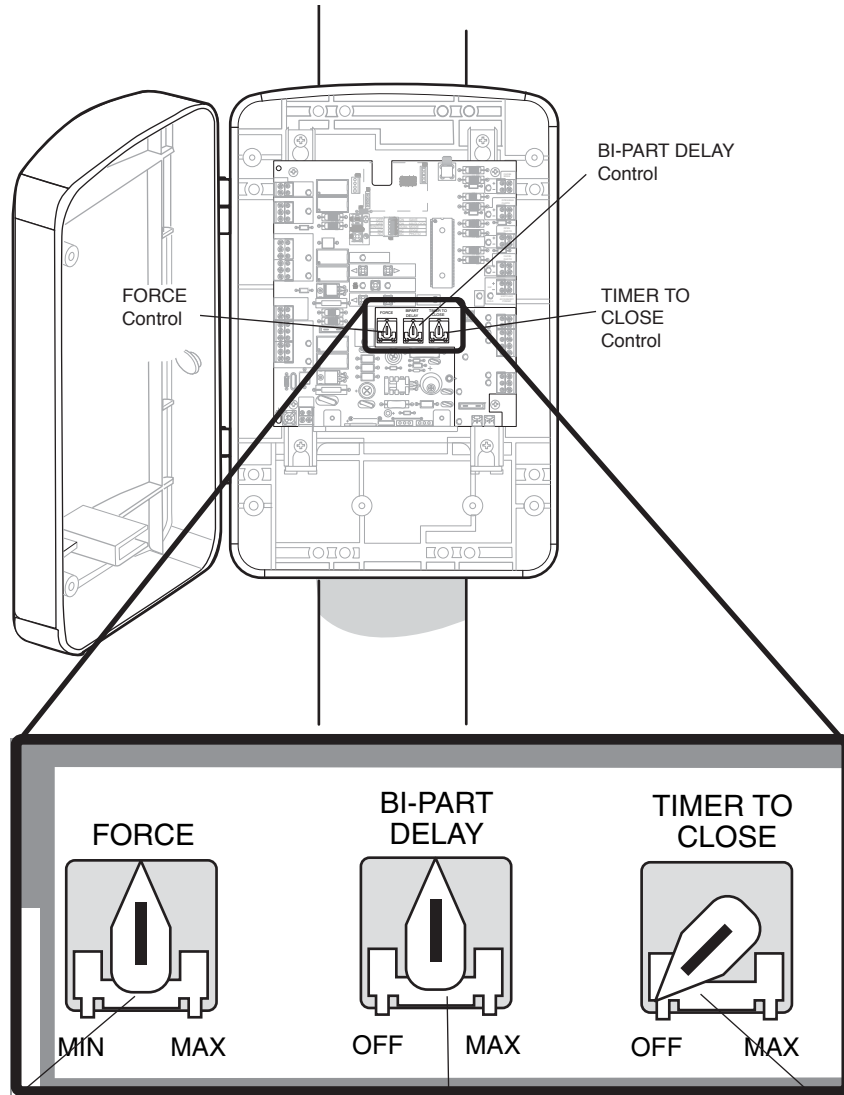

#### FORCE CONTROL

Set the force control such that the opener will complete a full cycle of gate travel but will reverse off an obstruction without applying an excessive amount of force.

#### BI-PART DELAY

Set the BI-PART DELAY to desired setting. The range is 0 to 8 seconds, 0 seconds is OFF.

**NOTE:** Used for Dual Gate installations only.

#### TIMER TO CLOSE ENABLE

Set the TIMER TO CLOSE to desired setting. The range is 0 to 180 seconds, 0 seconds is OFF.

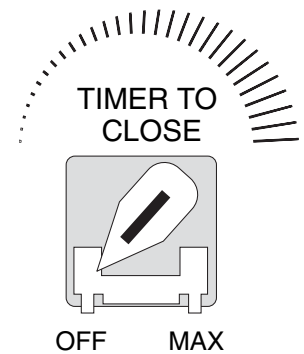
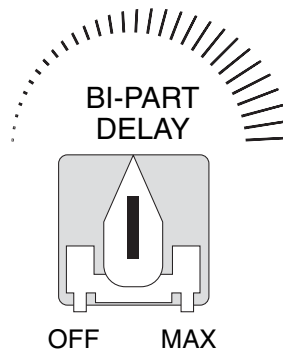
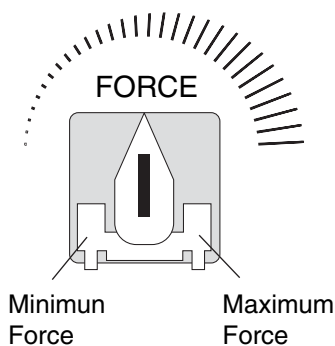

Your basic installation is now complete.

# OPTIONAL CONTROL AND SAFETY DEVICES

## To Add or Reprogram a Remote Control

1. Press and release “LEARN XMITTER” button (LED will light up).
2. Press and hold remote button, the LED will flash, alarm will beep twice and the LED will go out.
3. Repeat steps 1 and 2 until all remote controls are programmed (50 remote controls maximum).

**NOTE:** For highest level of security, we recommend the 315 MHz, Security+® line of products. Refer to Accessories.

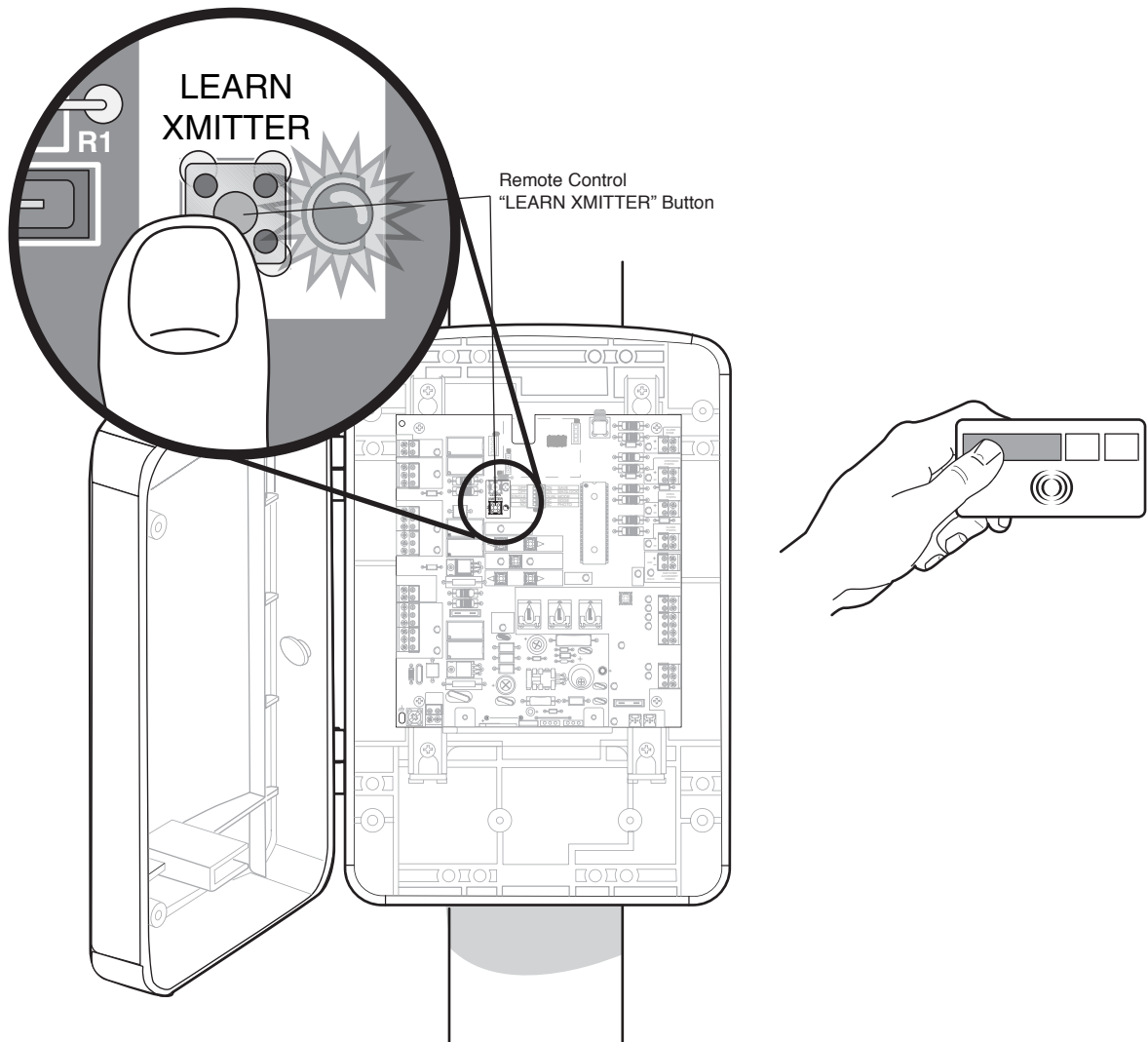

### To Erase All Codes

To deactivate any unwanted remote controls, first erase all codes:

Press and hold the “LEARN XMITTER” button on logic board until the learn indicator light goes out (approximately 6 seconds). All previous codes are now erased. Reprogram each remote control or keyless entry you wish to use.

NOTICE: To comply with FCC and or Industry Canada (IC) rules, adjustment or modifications of this receiver and/or transmitter are prohibited, except for changing the code setting or replacing the battery. THERE ARE NO OTHER USER SERVICEABLE PARTS.  
Tested to Comply with FCC Standards FOR HOME OR OFFICE USE. Operation is subject to the following two conditions: (1) this device may not cause harmful interference, and (2) this device must accept any interference received, including interference that may cause undesired operation.

# Dip Switch Settings

## SAVE SWITCH S1-1

This switch (S1-1) is used to save the settings for switches 2 through 5.

**NOTE:** When setting switches, the save switch must be in the off position prior to setting or changing switches for the change to be saved.

## MAG DELAY ENABLE

This switch (S1-2) enables the Maglock feature. On an open command there will be a .5 second delay before the motor starts, to allow the Maglock to release.

## MODE DUAL/SINGLE

This switch (S1-3) sets the mode as Dual or Single (Refer to page 24).

## SAFETY INPUTS

Swing gates allow four safety inputs. A DIP switch is required for determining between N/O and N/C edges and N/O and N/C eyes.

### EDGE INPUT

Set switch (S1-4) to the following settings:

N/O Edge (Active Close) = N/O dry contact edge or monitored edge

**NOTE:** Monitored Edges should be set in the N/O position, as the activation condition is shorting the terminals.

### EYE INPUT

This switch (S1-5) differentiates between N/O and N/C dry contact photoelectric eye inputs.

**NOTE:** Pulsing Chamberlain (CPS-L) photoelectric eyes will automatically learn in N/O mode (See Accessories).

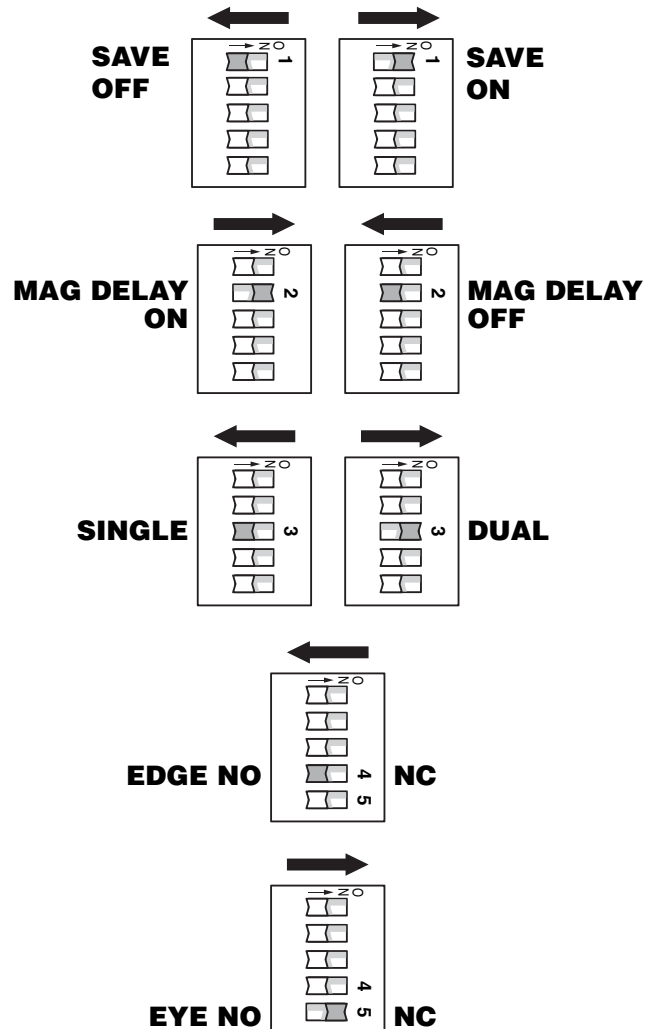
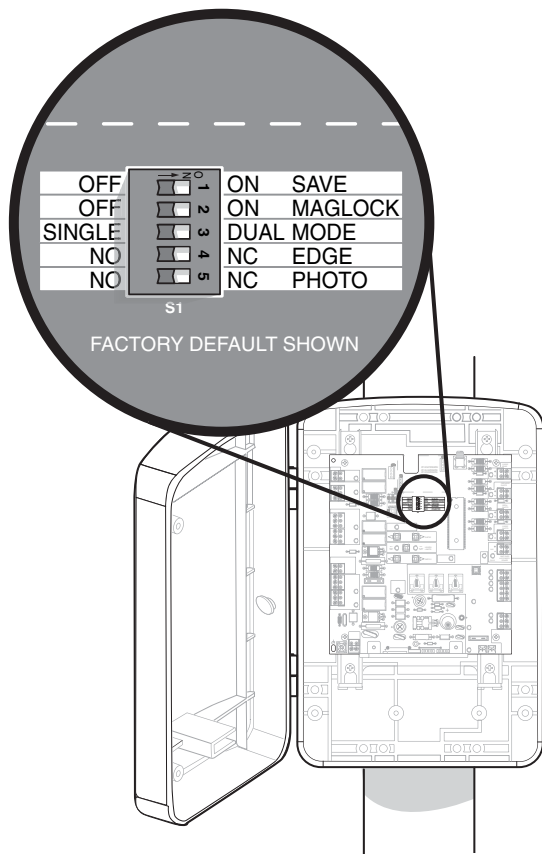



## Wire Stop Button (Optional)

A jumper wire is factory installed between the stop and common input.

**Stop (N/C)** - Stop only (does not reset alarm).

**NOTE:** Stop jumper is required for normal operation (the Stop LED will be lit except when the control board goes into Sleep Mode). Remove only if remotely mounted Stop button is added.

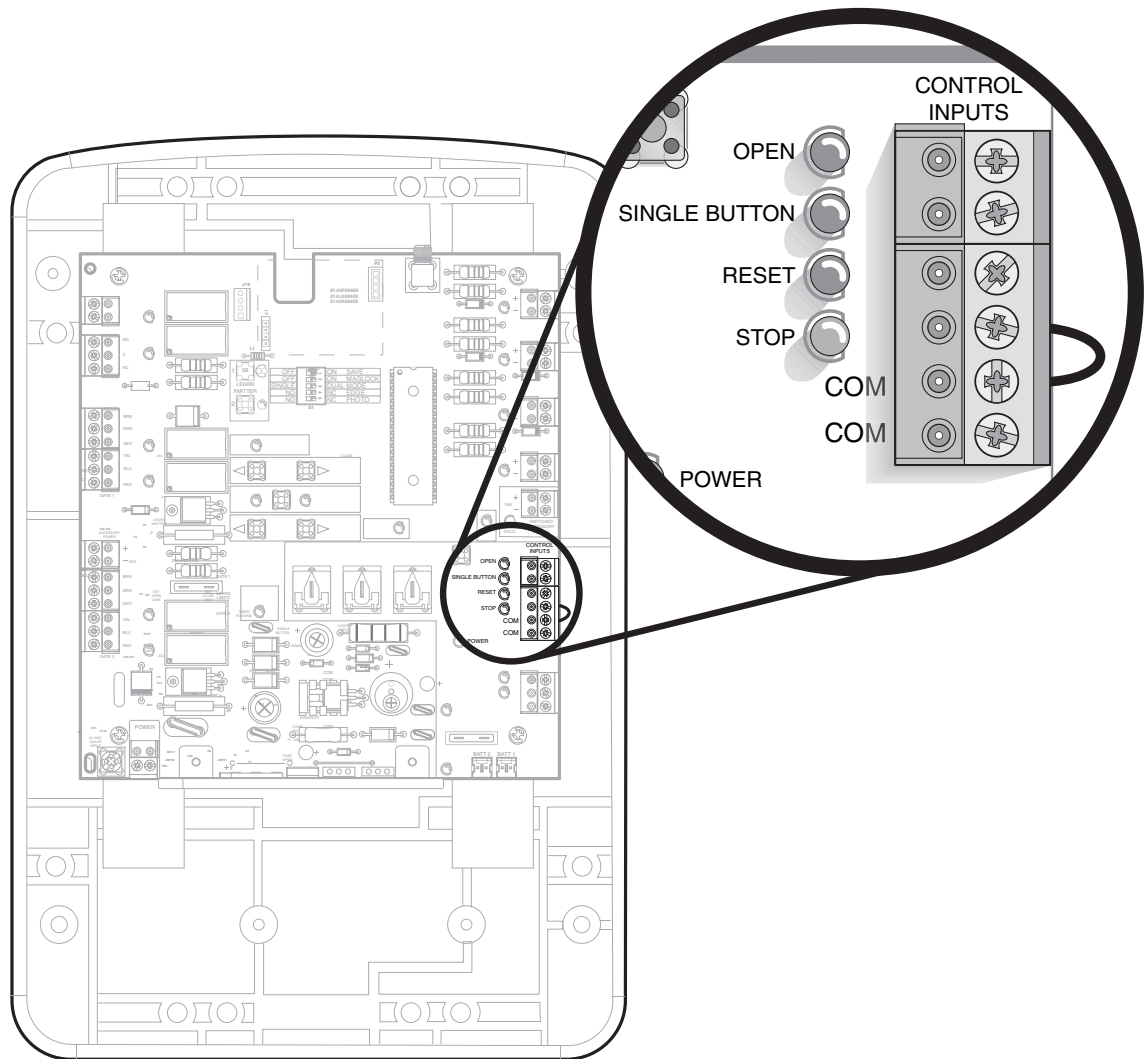

## OPEN

Opens only or reverses a closing gate.

## SBC (SINGLE BUTTON CONTROL) INPUT

This input will command the gate to OPEN / STOP / CLOSE / STOP in sequence.

## RESET CONTROL INPUT

The control box has a factory installed internal reset button. These terminals are intended for use with a single reset button that is installed within line of sight of the gate. This input functions to reset the alarms. This input will NOT stop the gate.

**NOTE:** All Control Inputs must be Normally Open (N.O.) dry contact type.

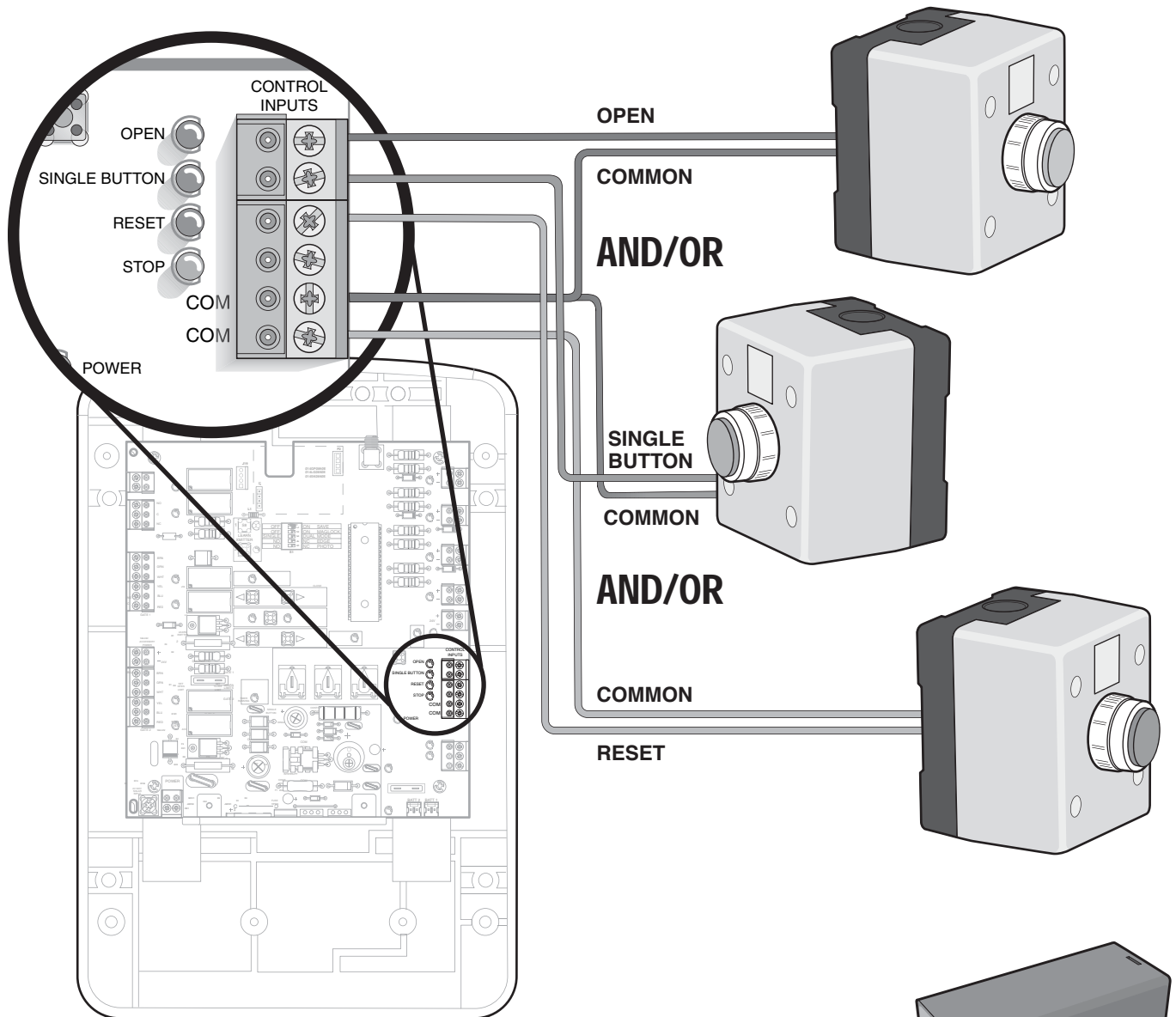

## OPEN INPUT AND EXIT LOOP

These terminals are intended for use as a general open control. Accessories such as telephone entry systems, radio receivers (open only applications), exit loop detectors, keypads and 7-day timers may be wired to this input.

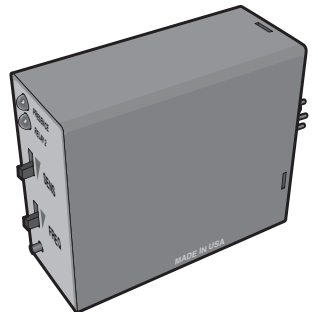

EXIT LOOP

# Loop Inputs

## Shadow Loop Input Terminal and Common

This input protects cars by preventing the gate from moving off of the open or close limit when the shadow loop input is active.

**NOTE:** Shadow Loop is disabled when gate is moving.

## Interrupt Loop Input Terminal and Common

This input functions to reverse a closing gate to the open limit. Latching this input will reset the timer to close.

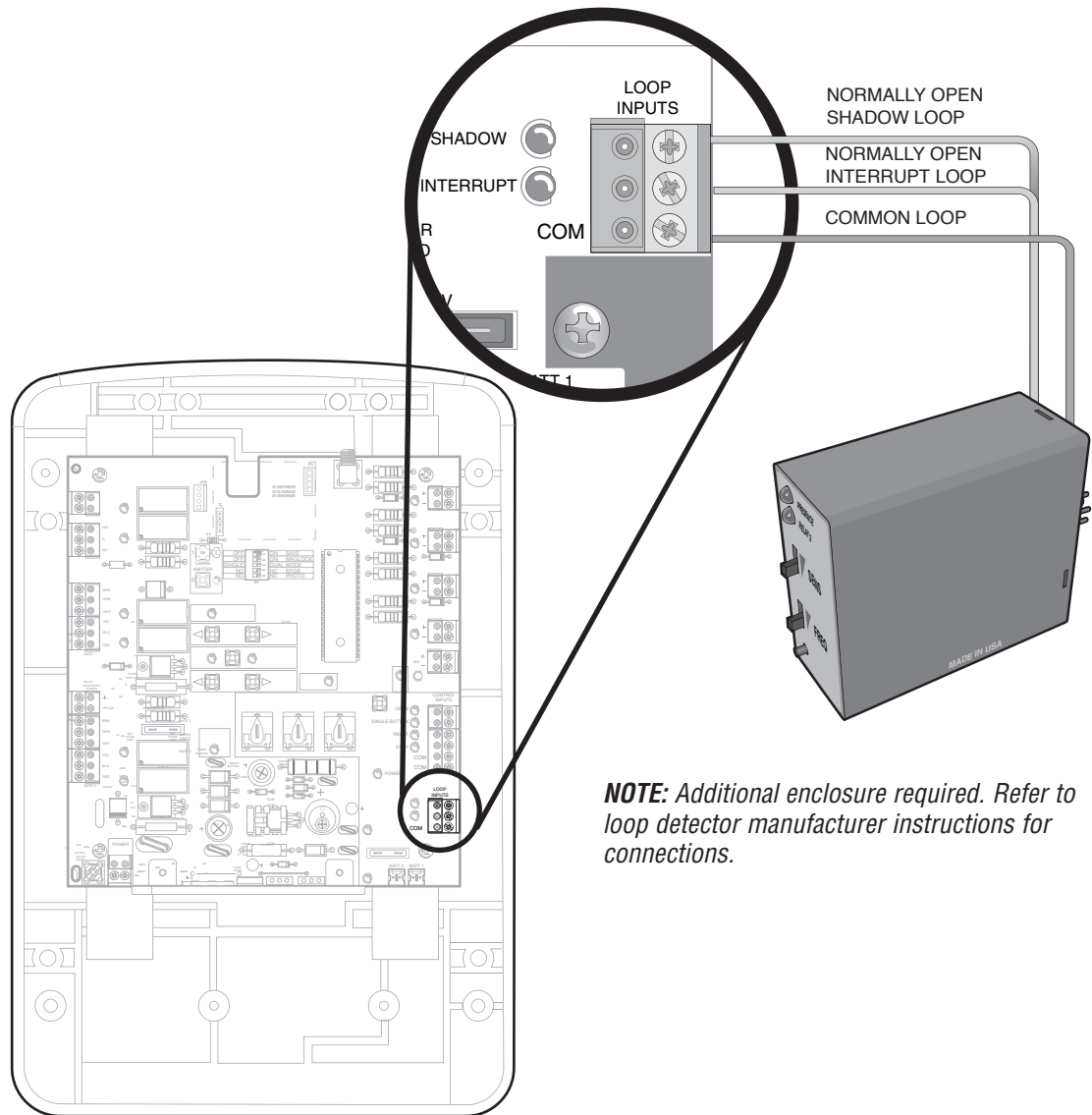

**NOTE:** Additional enclosure required. Refer to loop detector manufacturer instructions for connections.

## Photo/Edge Inputs (P6-7-8 and 9)

### Terminal P6 – Close Safety Edge

This input will reverse a closing gate. It will disable the Timer-to-Close if that feature has been enabled. Activating this input while the gate is opening will have no effect.

Order part number LA400-BOX to enclose safety electronics.

### Terminal P8 – Open Safety Edge/Photo Eye (Entrapment)

If an Open Edge device or a Retro-Reflective Photo Eye has been connected to Terminal P8, then this input will reverse an opening gate for 2 seconds then stop. Activating this input with an Open Edge device or a Retro-Reflective Photo Eye connected to Terminal P8 while the gate is closing will have no effect.

If a Chamberlain Pulsing Photo Eye (See Accessories) has been connected to Terminal P8, then this input will pause an opening gate until the obstruction has been removed. Upon removing the obstruction, the gate will continue to open. Activating this input with a Chamberlain Pulsing Photo Eye (See Accessories) connected to Terminal P8 while the gate is closing will have no effect.

### Terminal P7 – Open Safety Photo Eye (Entrapment)

This input will pause an opening gate until the obstruction has been removed. Upon removing the obstruction, the gate will continue to open. Activating this input while the gate is closing will have no effect.

### Terminal P9 – Close Safety Photo Eye

This input will reverse a closing gate to the open limit. Activating this input while the gate is opening will have no effect. The Timer-to-Close will reactivate at the open limit.

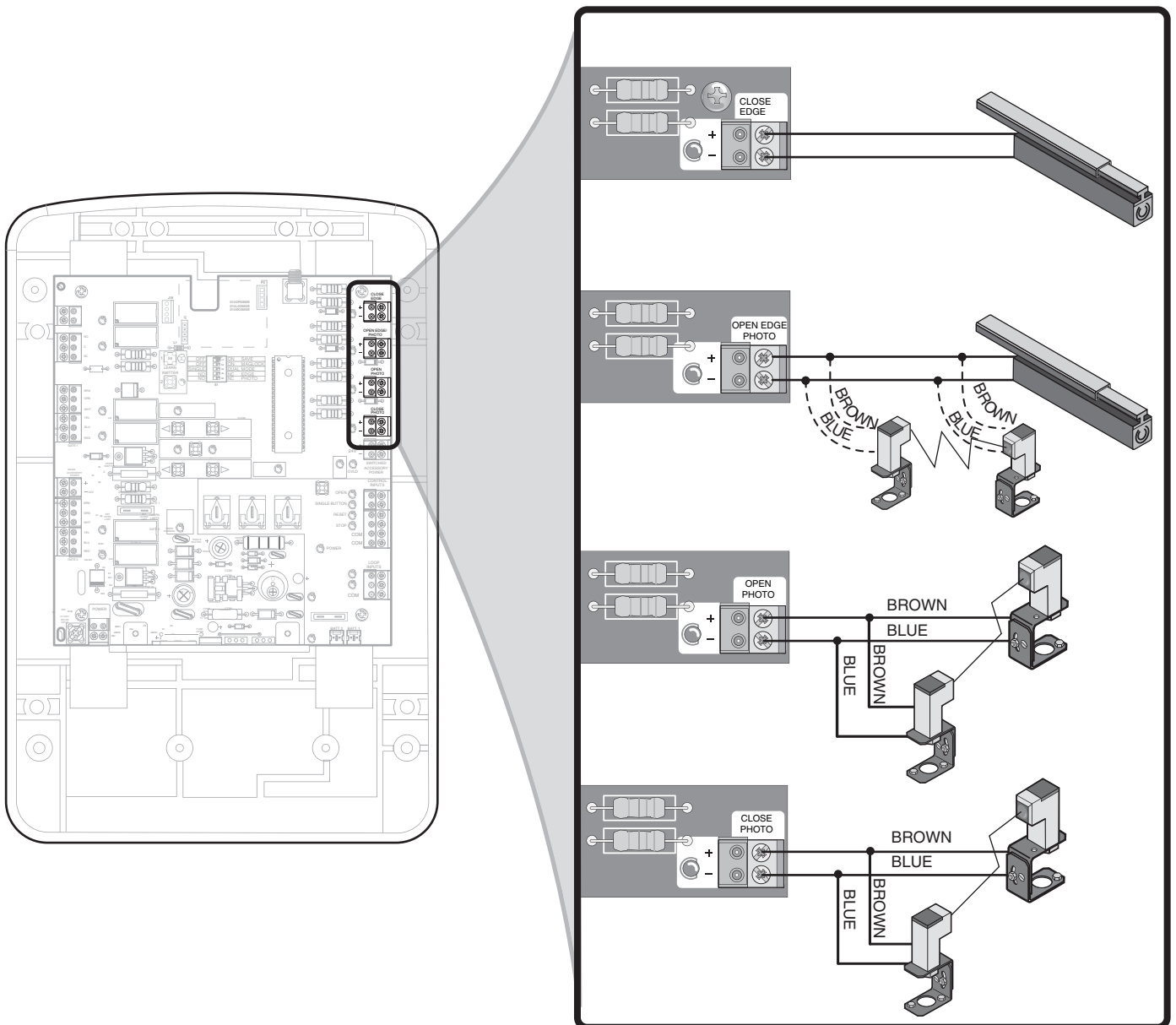

# Safety Accessories for Secondary Entrapment Protection

The following devices are acceptable for Safety Accessories for secondary entrapment protection. These devices have been tested with the LA400 to meet the requirements of UL325 and UL991.

PHOTO-ELECTRIC CONTROLS		
MODEL	DESCRIPTION	VOLTAGE
CPS-LN4	Emitter, receiver and mounting brackets - 30' (9 m) Ranges	+24Vdc
CPS-RN4	Emitter with reflector and mounting brackets	+24Vdc
SENSING EDGES		
MODEL	DESCRIPTION	
G65MG0204	Miller MG020 2-wire electric edge for gates. Sensitized on three sides. (Requires mounting channel. PIN:G65ME120C5)	
G65MG0205	Miller MG020 2-wire electric edge for gates. Sensitized on three sides. (Requires mounting channel. PIN:G65ME120C5)	
G65MGR205	Miller MGR20 2-wire electric edge in 5' (1.5 m) lengths for 2" (5 cm) round post.	
G65MGS205	Miller MGR20 2-wire electric edge in 5' (1.5 m) lengths for 2" (5 cm) square post.	

## Maglock

When enabled, the maglock output is activated (energized) while the gate is in motion.

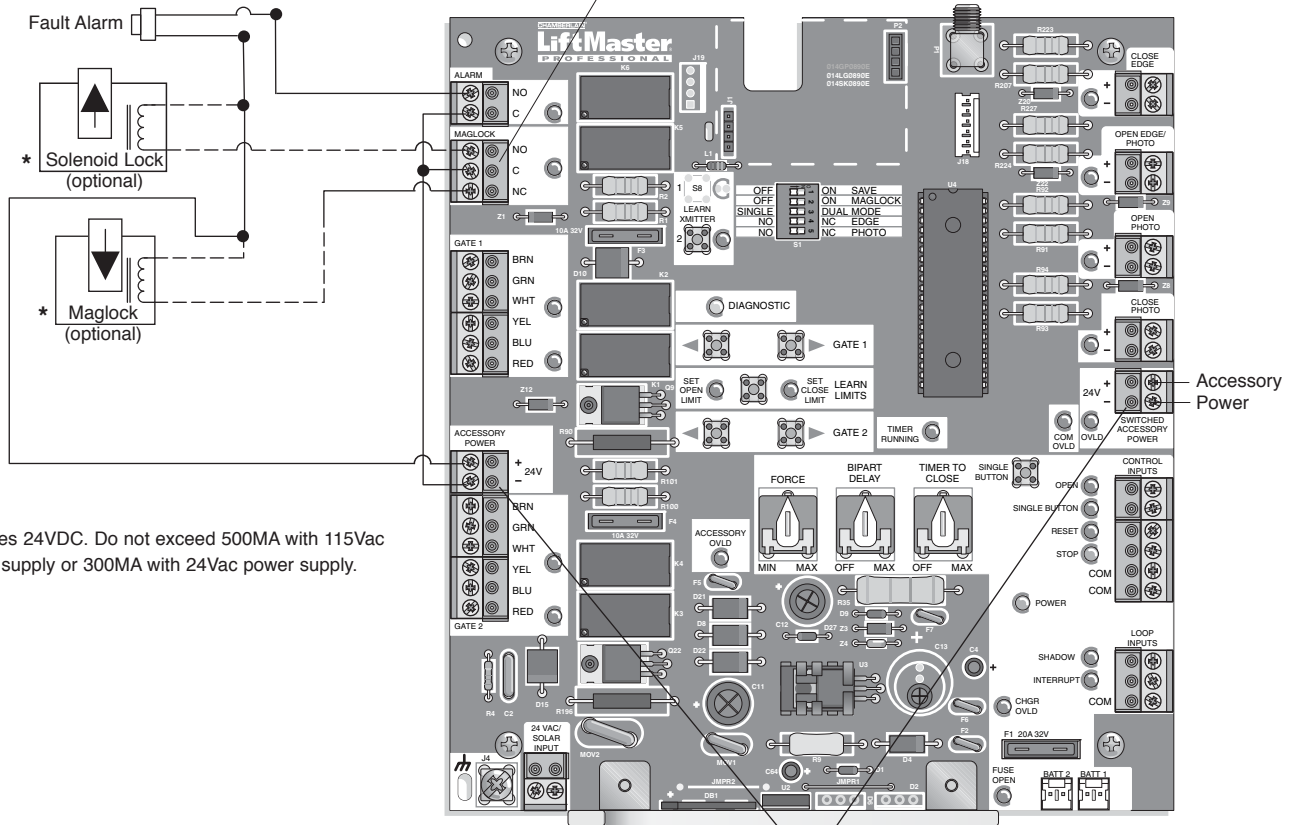

\* Provides 24VDC. Do not exceed 500MA with 115Vac power supply or 300MA with 24Vac power supply.

## Auxiliary Output Power for Optional Devices

(2) +24Vdc Outputs have been provided for optional devices

# OPERATION

## Reset Button

The reset button is located on the outside of the control box and serves several functions.

### Obstruction/Entrapment Reset

If gate encounters two consecutive obstructions, the control system will go into an entrapment alarm condition and the control board will require resetting. This is achieved by simply pushing the “Reset Button” located on the outside of the control box.

### Party Mode (Timer Defeat - Hold Open)

When the “Timer to Close” feature is activated for normal daily operation and you wish to leave the gate(s) in the open position for any extended period of time you can activate the “Party Mode” by pushing the “Reset Button” located on the outside of the electrical box. To exit this mode, simply give the gate(s) a command to run by using the remote control. This will close the gate(s) and return the operator to normal operation.

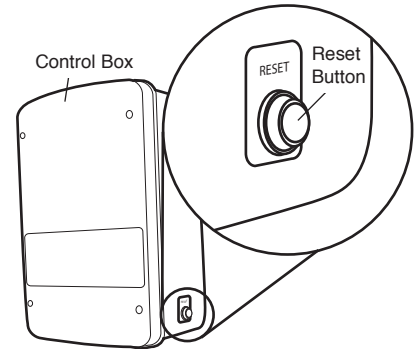

## Remote Control

Once the remote control has been programmed unit will operate as follows:

When gate is in the closed position, activation of the remote control button will open the gate. During the open cycle another activation of the remote control will stop the gate and the next activation of the remote control will close the gate.

When the gate is in the open position, activation of the remote control button will close the gate. During the close cycle another activation of the remote control will stop the gate and the next activation of the remote control will open the gate.

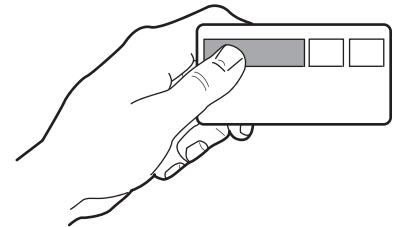

## Manual Release

The drive mechanism can be released. The gate can then be operated manually (power failure). With a new drive mechanism, the release action may sometimes feel stiff/jerky. This is normal and has no effect on function.

### Release

1. Insert the key into the lock.
2. Turn the key counter-clockwise 180°.
3. Turn the release lever counter-clockwise 180°.
4. Done! Operator is in manual mode.

### Engage

1. Turn the release lever clockwise 180°. This engages the motor.
2. Turn the key clockwise 180°. This locks the release lever.
3. Remove the key and store in a safe place.
4. Done! Back in automatic mode.

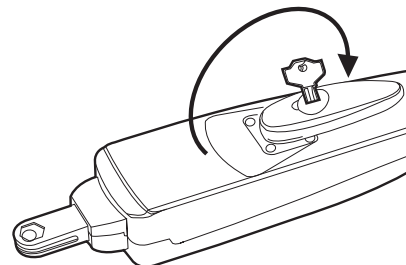
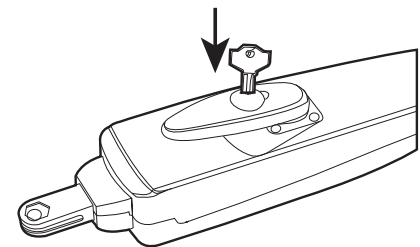

# MAINTENANCE

## IMPORTANT SAFETY INSTRUCTIONS

### **WARNING**

### To reduce the risk of SEVERE INJURY or DEATH:

1. READ AND FOLLOW ALL INSTRUCTIONS.
2. NEVER let children operate or play with gate controls. Keep the remote control away from children.
3. ALWAYS keep people and objects away from the gate. NO ONE SHOULD CROSS THE PATH OF THE MOVING GATE.
4. Test the gate operator monthly. The gate MUST reverse on contact with a rigid object or stop when an object activates the non-contact sensors. After adjusting the force or the limit of travel, retest the gate operator. Failure to adjust and retest the gate operator properly can increase the risk of INJURY or DEATH.
5. Use the emergency release ONLY when the gate is not moving.
6. KEEP GATES PROPERLY MAINTAINED. Read the owner's manual. Have a qualified service person make repairs to gate hardware.
7. The entrance is for vehicles ONLY. Pedestrians MUST use separate entrance.
8. Disconnect ALL power BEFORE performing ANY maintenance.
9. ALL maintenance MUST be performed by a LiftMaster professional.
10. **SAVE THESE INSTRUCTIONS.**

### CHECK AT LEAST ONCE EVERY

DESCRIPTION	TASK	MONTH	3 MONTHS	6 MONTHS	12 MONTHS
External entrapment protection systems	Check for proper operation	●			Complete Check Out
Gate warning signs	Make sure they are present		●		
Manual disconnect	Check and operate			●	
Gate	Inspect for wear or damage			●	
Accessories	Check all for proper operation			●	
Electrical	Inspect all wire connections			●	
Frame bolts	Check for tightness			●	
Total unit	Inspect for wear or damage			●	

### CAUTION

To reduce the risk of FIRE or INJURY to persons, use ONLY LiftMaster part #K74-30762 for replacement batteries.

#### NOTES:

1. Disconnect power before servicing.
2. Severe or high cycle usage will require more frequent maintenance checks.
3. Inspection and service should always be performed anytime a malfunction is observed or suspected.
4. When servicing, please do some "house cleaning" of the operator and the area around the operator. Pick up any debris in the area. Clean the operator as needed.
5. It is suggested that while at the site voltage readings be taken at the operator. Using a Digital Voltmeter, verify that the incoming voltage to the operator it is within ten percent of the operators rating.



## **WARNING**

To avoid **SERIOUS** personal **INJURY** or **DEATH** from electrocution, **DISCONNECT** electrical power to operator **BEFORE** proceeding.

## **CAUTION**

To reduce the risk of **FIRE** or **INJURY** to persons, use **ONLY** LiftMaster part #K74-30762 for replacement batteries.

### **Battery Replacement**

1. Disconnect power to operator.
2. Open the control box cover.
3. Remove all quick connect terminals in use to the control board. Remember location of all wire connections for reinstallation.
4. Remove control board and mounting plate.
5. Disconnect terminals leads to both batteries.
6. Replace both batteries and connect red wires to the positive (+) terminals (red). Connect black wires to the negative (-) terminals (black).
7. Install control board and mounting plate.
8. Reconnect all quick connect terminals to the control board.
9. Close cover of control box.
10. Reconnect power to operator.

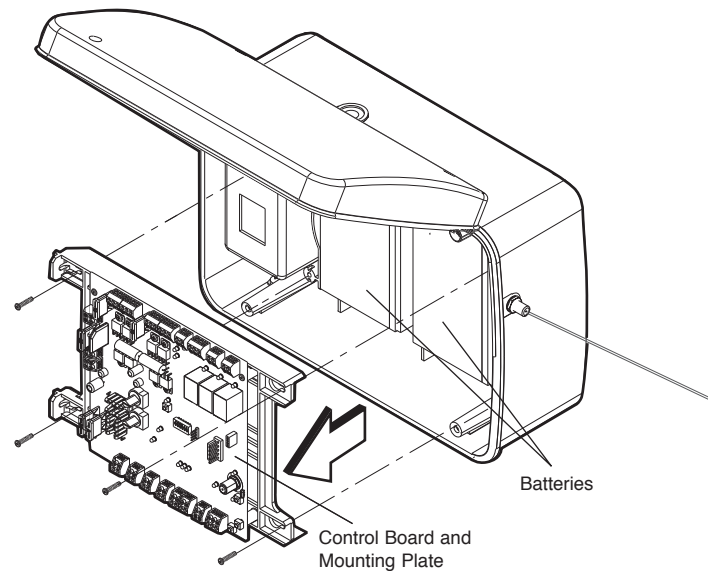

# BASIC CONTROL BOARD LAYOUT

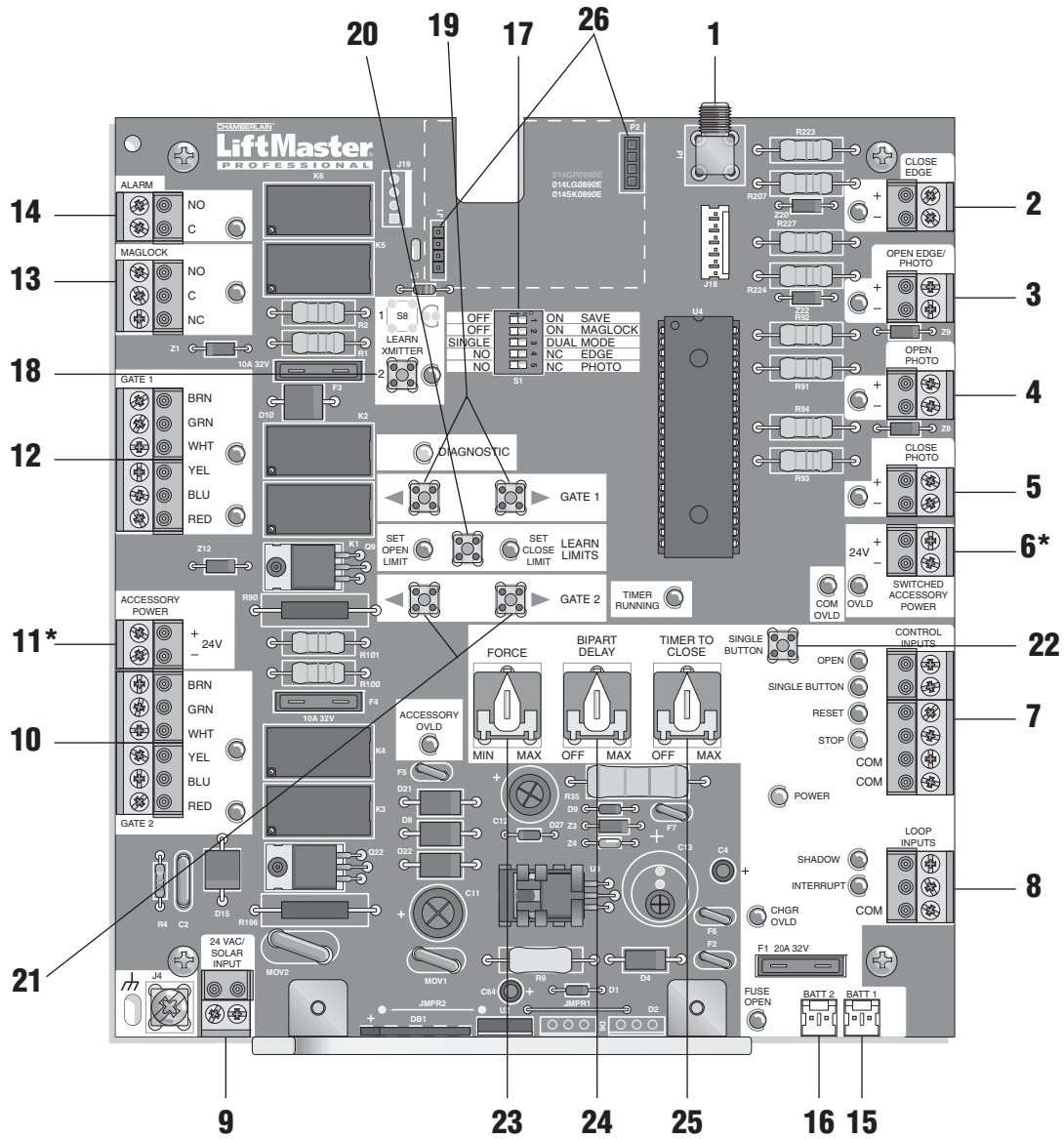

ITEM	DESCRIPTION	FUNCTION	ITEM	DESCRIPTION	FUNCTION
1	Connector P1	Antenna Input	14	Connector P15	Alarm
2	Connector P6	Close Edge	15	Connector	Battery 1
3	Connector P8	Open Edge/Photo	16	Connector	Battery 2
4	Connector P7	Open Photo	17	Dip Switch	S1
5	Connector P9	Close Photo	18	Pushbutton	Learn Xmitter - Program Remote
6	Connector P12	Switched Accessory Power*	19	Pushbuttons	Gate 1 - Jog Learn Limit
7	Connector P10	Control Inputs	20	Pushbutton	Learn Limits
8	Connector P11	Loop Inputs	21	Pushbuttons	Gate 2 - Jog Learn Limit
9	Connector P5	24Vac/Solar Input	22	Pushbutton	Single Button
10	Connector P16	Gate 2	23	Potentiometer	Force
11	Connector P13	Accessory Power*	24	Potentiometer	Bi-Part Delay
12	Connector P17	Gate 1	25	Potentiometer	Timer to Close
13	Connector P14	Maglock/Solenoid	26	Connector	Receiver

\*See page 40 for max current draw

# WIRING DIAGRAM

1. ANTENNA INPUT
2. CLOSE EDGE
3. OPEN EDGE/PHOTO EYE
4. OPEN PHOTO EYE
5. CLOSE PHOTO EYE
6. 24VDC ACCESSORY OUTPUT
7. CONTROL INPUTS/EXIT LOOP
8. LOOP INPUTS, SAFETY/SHADOW
9. TRANSFORMER INPUT/SOLAR INPUT (OPTIONAL)
10. SECOND - OPERATOR ARM CONNECTION
11. 24VDC ACCESSORY OUTPUT
12. MASTER OPERATOR ARM CONNECTION
13. MAGLOCK/SOLENOID OUTPUT
14. FAULT ALARM OUTPUT
15. BATTERY INPUT #1
16. BATTERY INPUT #2
17. DIP SWITCH, S1
18. LEARN XMITTER
19. MASTER GATE JOG
20. LIMIT SET
21. SECOND GATE JOG
22. SBC (SINGLE BUTTON CONTROL)
23. FORCE SET
24. BIPART DELAY SET
25. TIMER TO CLOSE SET

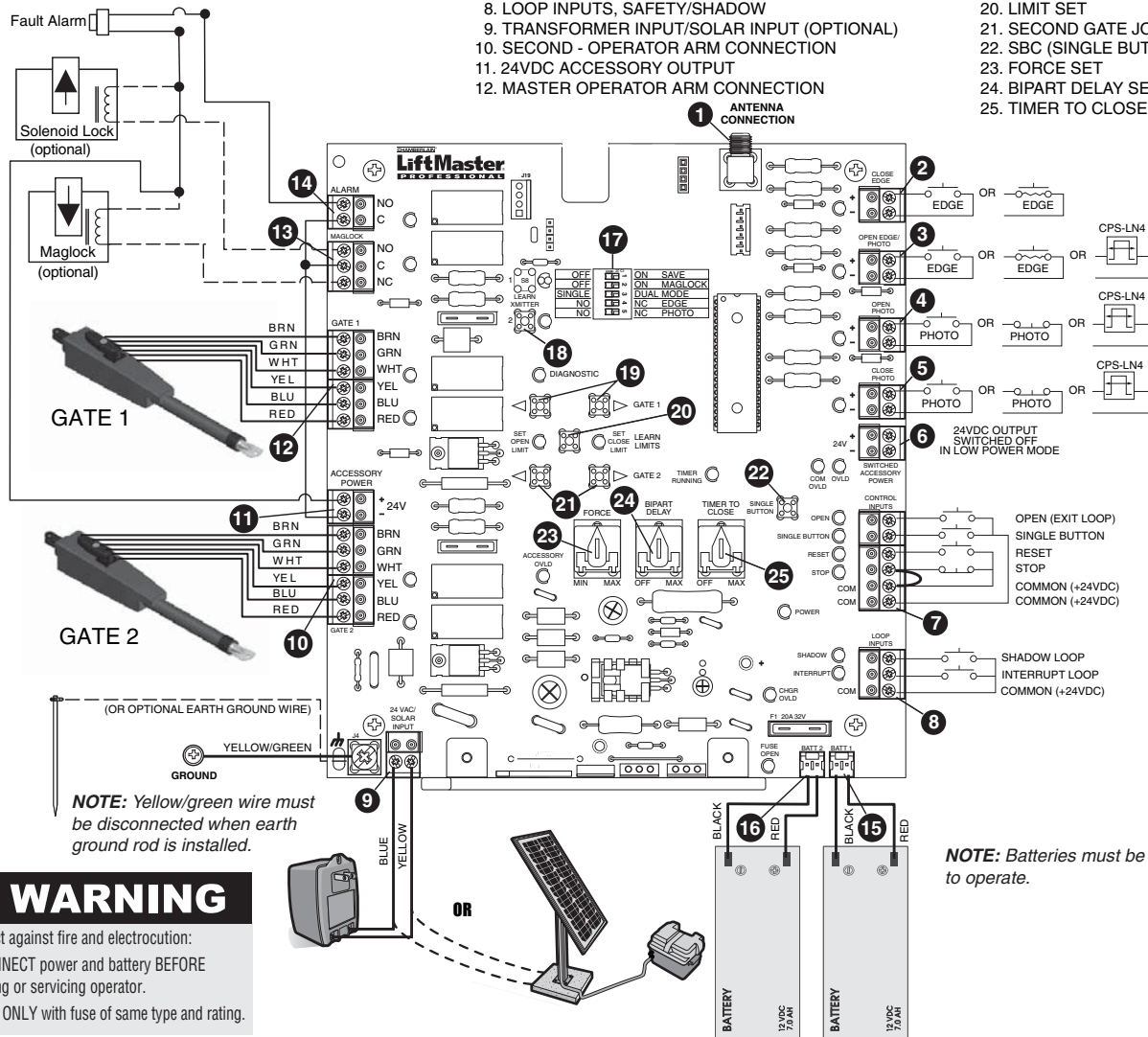

**⚠ WARNING**

To protect against fire and electrocution:

- DISCONNECT power and battery BEFORE installing or servicing operator.
- Replace ONLY with fuse of same type and rating.

# TROUBLESHOOTING

<b>FAULT</b>	<b>POSSIBLE CAUSE</b>	<b>FIX</b>
<b>OPERATOR IS DEAD</b> No LED lights are on.	<ol style="list-style-type: none"> <li>1) No voltage to board.</li> <li>2) Bad control board.</li> </ol>	<ul style="list-style-type: none"> <li>➤ Battery must be &gt;23V, AC or Solar needs to be connected.</li> <li>➤ Replace control board.</li> </ul>
<b>OPERATOR DOES NOT RUN</b> Unit does not respond to any commands.	<ol style="list-style-type: none"> <li>1) Low/disconnected battery.</li> <li>2) Remote not programmed.</li> <li>3) STOP connection loose/disconnected.</li> <li>4) Constant Open Command (Check LED's).</li> <li>5) Limits not programmed correctly.</li> <li>6) Bad control board.</li> </ol>	<ul style="list-style-type: none"> <li>➤ Voltage must be &gt;23V at battery connection.</li> <li>➤ See Programming Remote instructions.</li> <li>➤ Check STOP connections.</li> <li>➤ Clear all Open/Safety devices from obstruction.</li> <li>➤ See Programming Limits instructions.</li> <li>➤ Replace control board.</li> </ul>
<b>MOTOR DOES NOT RUN</b> Relays "click" when radio or SBC signal is given, but the operator does not move.	<ol style="list-style-type: none"> <li>1) Low Battery.</li> <li>2) Cable wiring between control box and operator arm disconnected or loose.</li> <li>3) Batteries not connected.</li> <li>4) Bad motor.</li> <li>5) Bad control board.</li> </ol>	<ul style="list-style-type: none"> <li>➤ Voltage must be &gt;23V at battery connection.</li> <li>➤ Check wiring on control board to arm, replace wire if needed.</li> <li>➤ Connect batteries.</li> <li>➤ Replace motor.</li> <li>➤ Replace control board.</li> </ul>
<b>GATE STOPS AND REVERSES</b> (Force Reversal)	<ol style="list-style-type: none"> <li>1) Gate met an obstruction.</li> <li>2) Force set too low.</li> <li>3) Bad gate hardware.</li> <li>4) Incorrect Arm installation.</li> </ol>	<ul style="list-style-type: none"> <li>➤ Clear gate from obstruction.</li> <li>➤ See Force Adjustment section.</li> <li>➤ Service/replace gate hardware.</li> <li>➤ See Installation section of operator arm.</li> </ul>
<b>RPM REVERSAL</b>	<ol style="list-style-type: none"> <li>1) Obstructed Arm (bottoms out).</li> <li>2) Bad RPM Sensor.</li> <li>3) Too much mA pulled off board.</li> </ol>	<ul style="list-style-type: none"> <li>➤ Check for obstruction on arm, verify arm is not bottomed out.</li> <li>➤ Replace arm.</li> <li>➤ Move accessories to separate power source. Use reference chart on next page to determine max mA draw for circuit board.</li> </ul>
<b>GATE STOPS</b> Gate starts to run, then stops and does not reverse.	<ol style="list-style-type: none"> <li>1) Low battery.</li> <li>2) Gate met an obstruction.</li> </ol>	<ul style="list-style-type: none"> <li>➤ Voltage must be &gt;23V at battery connection.</li> <li>➤ Clear gate from obstruction.</li> </ul>
<b>GATE OPENS BUT DOES NOT CLOSE</b>	<ol style="list-style-type: none"> <li>1) Constant Open Command (Check LED's).</li> <li>2) Timer to Close not set.</li> <li>3) Accessory device wired to Open Only command.</li> </ol>	<ul style="list-style-type: none"> <li>➤ Clear all Open/Safety devices from obstruction.</li> <li>➤ See Timer to Close section for adjustment instructions.</li> <li>➤ Rewire desired accessory device to Single Button Input.</li> </ul>
Audible beeps (3 times) when command is given.	<ol style="list-style-type: none"> <li>1) Battery Low &gt;23.5V</li> </ol>	<ul style="list-style-type: none"> <li>➤ Operator will resume normal operation once battery voltage reaches 24V.</li> </ul>
<b>GATE'S DO NOT OPEN/CLOSE IN SYNC</b>	<ol style="list-style-type: none"> <li>1) Bi-Part Delay not set.</li> <li>2) Limits not programmed correctly.</li> <li>3) Incorrect Arm Installation</li> </ol>	<ul style="list-style-type: none"> <li>➤ See Bi-Part Delay section for adjustment instructions.</li> <li>➤ See Programming Limits section for instructions.</li> <li>➤ See Installation section for instructions.</li> </ul>
<b>GATE DOES NOT AUTOMATICALLY CLOSE</b> Auto Close Timer not closing gate.	<ol style="list-style-type: none"> <li>1) Timer to Close not turned on.</li> <li>2) Gate has opened on Obstruction Reversal.</li> <li>3) Operator in "Party Mode".</li> <li>4) Constant Open Command (Check LED's).</li> </ol>	<ul style="list-style-type: none"> <li>➤ See Timer to Close section for instructions.</li> <li>➤ Check DIAG code, clear obstruction.</li> <li>➤ Use Remote/SBC to resume normal operation.</li> <li>➤ Clear all Open/Safety devices from obstruction.</li> </ul>
<b>ACCESSORY DEVICE NOT WORKING PROPERLY</b>	<ol style="list-style-type: none"> <li>1) Not installed properly.</li> <li>2) Enabling Switch not turned on.</li> <li>3) Loose/disconnected wires.</li> <li>4) Bad accessory device</li> </ol>	<ul style="list-style-type: none"> <li>➤ Check for proper installation of accessory.</li> <li>➤ Turn applicable switches on.</li> <li>➤ Check proper installation of wires.</li> <li>➤ Replace accessory device.</li> </ul>

<b>MAX CURRENT DRAW</b>
115 power to control box - 500mA accessory power, 150mA switched accessory power.
24V power to control box depending on wire gauge and distance - 300mA accessory power, 75mA switched accessory power.
Solar power to control box - 0mA accessory, 50mA switched accessory power.

### DIAGNOSTIC CODES

<b># OF BLINKS</b>	<b>MEANING</b>
1	No Stop Switch Connected
2	Gate 1 Arm Disengaged
3	Gate 2 Arm Disengaged
4	Both Gate Arms Disengaged
5	RPM Reversal
6	Force Reversal
7	Processor Reset
8	ROM Check Failed
9	RAM Check Failed
10	EEPROM Check Failed - Reset Limits

# REPAIR PARTS

Refer to the parts lists below for replacement parts available for your operator. If optional modifications and/or accessories are included with your operator, certain components may be added or removed from these lists.

CONTROL BOX LA400-CONT			
ITEM	PART #	DESCRIPTION	QTY
1	K001A6039	Control Board	1
2	K75-15480	Control Box & Cover with Gasket	1
3	K75-30764	Control Board Bracket	1
4	K23-19380	Reset Switch	1
5	K74-19499	Antenna	1
6	K74-30762	Battery	2
7	K74-30763	Transformer	1
8	K76-19446	Alarm	1
<b>Not Shown</b>	K74-30941	ATC Fuse Kit Includes 20 Amp (1), 15 Amp (2)	
	K001A5747-2	390 MHz Receiver Module	
	K001A5747	315 MHz Receiver Module	

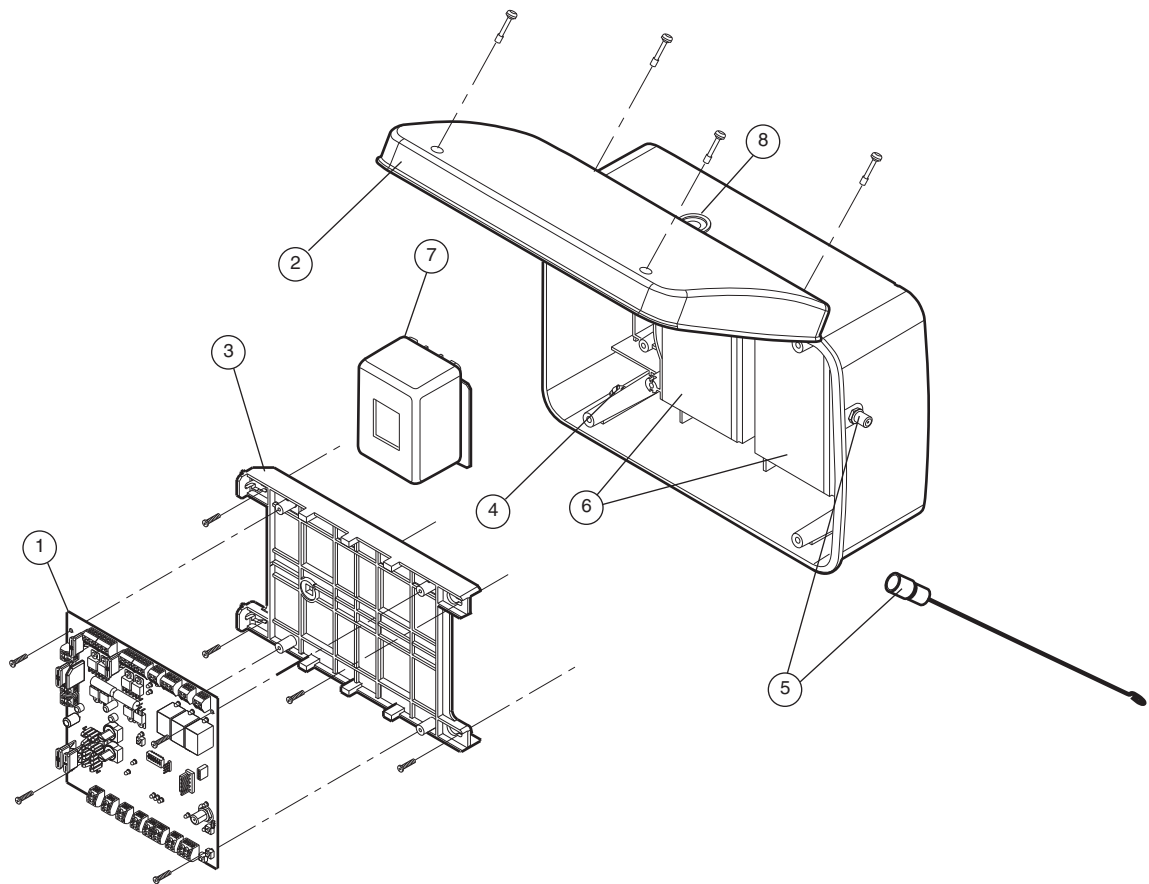



## ACTUATOR ARM KITS

ITEM	PART #	DESCRIPTION	QTY
1	41ASWG-442SA	Release Lever	1
2	41ASWG-438SA	Motor with Limit Switch Harness	1
3	41ASWG-0014SA	Rear Connector	1
4	41ASWG-489	Cable 24V with Connector	1
<b>Not Shown</b>	41ASWG-0119	Release Key	1
	K77-19130	Hardware Bag	1
<b>Complete With:</b> Gate bracket, Post bracket, Extension bracket and Hardware			

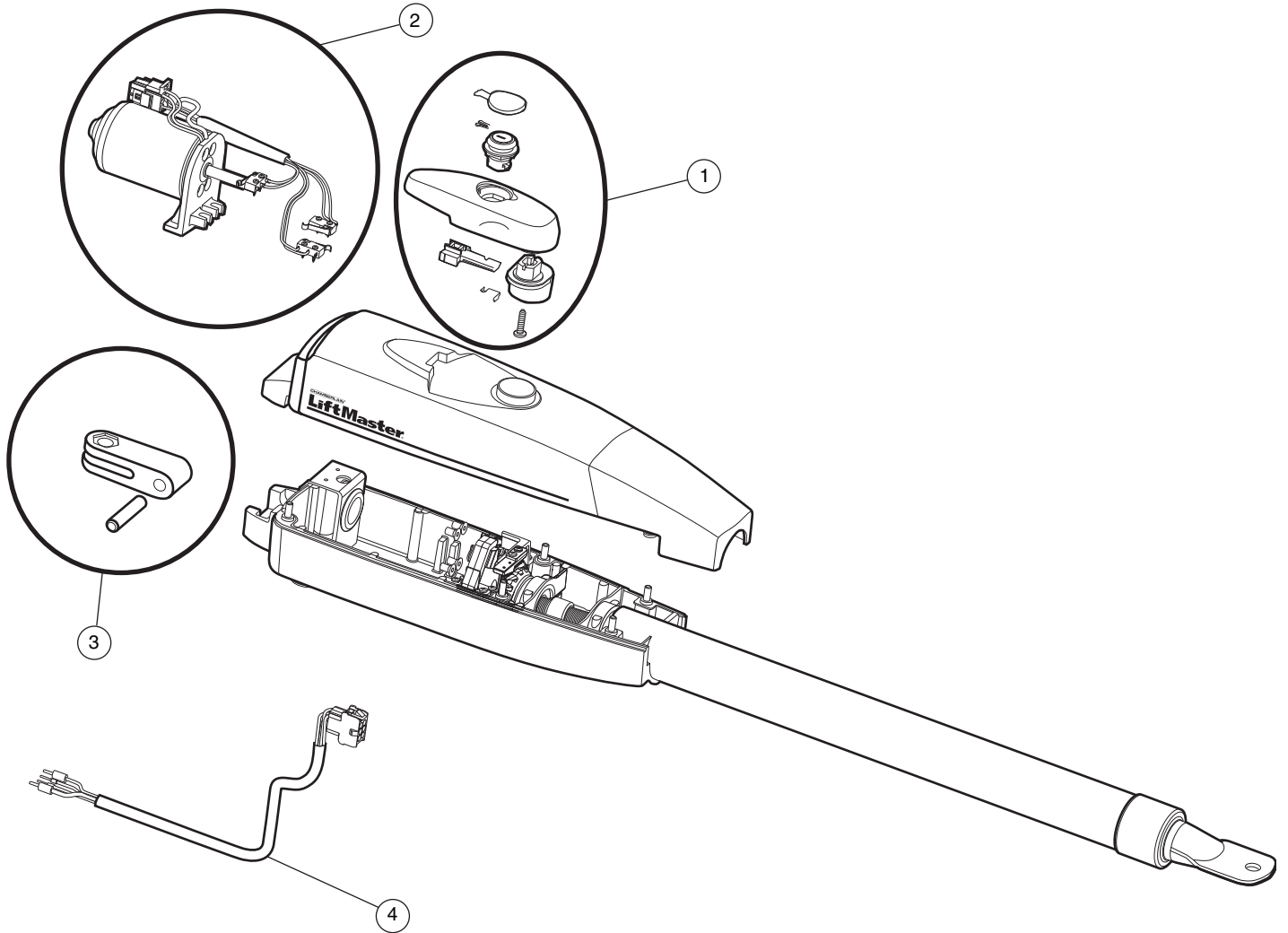

# LA400 SWING GATE ACCESSORIES

50-19503

## Push to Open Bracket

Used to allow the gate operator to push the gate open.

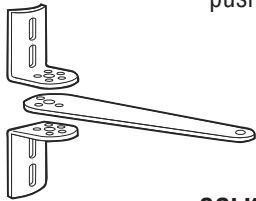

377LM

## SECURITY+® Keyless Entry (☺):

Enables homeowner to operate gate by entering a password on a specially designed keyboard. Also can add a temporary password for visitors or service persons. This temporary password can be limited to a programmable number of hours or entries.

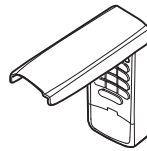

SOLKIT12V

## SOLKIT12V (Single Panel) SOLKIT12V-2P (Two Panels):

Kit contains: Battery management module, outdoor battery case (battery not included), solar panel(s). When power is not close by, solar may be the right option. For more information, please contact customer service or see pre-sale solar application guide.



LM202

## Vehicle Detecting Driveway Probe:

One piece outdoor buried vehicle motion detector with sensing probe is housed in a small relay type housing. Provides for free exit.

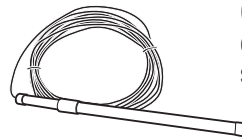

02101

## 1-Button Station:

Steel enclosure wired station will allow for a Open, Close, Stop command of the gate.



GC824-12

## Gate Solenoid Lock:

Heavy all steel construction. Failsafe operation keeps gate locked if power is lost. Can be welded onto gate or post. 24Vdc operation, solenoid-activated release. Can be released in case of an emergency. Requires separate power supply (Model ARMPS).

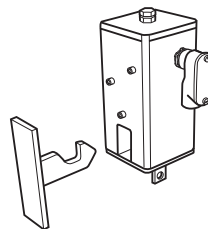

370LM

## 3-Button Mini-Remote Control with SECURITY+® (☺):

With key ring and fastening strip.



GC838

## Magnetic Gate Lock:

Incredible 1,200 Lb. holding force. Operates on 12 or 24Vdc. Low power consumption. Universal mounting holes for ease of installation. Automatically releases when power is lost. Requires separate power supply (Model ARMPS).

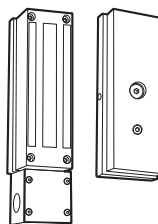

373LM

## 3-Button SECURITY+® Remote Control (☺):

Includes visor clip.



50-19509

## 6" Post Mounting Kit for control box

86LM

## Remote Antenna Mounting Kit:

Kit contains antenna bracket and 15' (4.6 m) of cable. Recommended for increasing the effective range of remote controls.



50-19511

## 4" Post Mounting Kit for control box

50-19512

## 2 1/2" Post Mounting Kit for control box

GCPSN4

## Commercial Protector System®:

Maximum range is 45' 24V. Includes mounting hardware and electrical interface box.

CPS-LN4

## Commercial Protector System® (Direct Connect):

Maximum range is 45' 24V. Includes mounting hardware.

# WARRANTY POLICY AND SERVICE

## LIFTMASTER® TWO YEAR LIMITED WARRANTY

The Chamberlain Group, Inc. warrants to the first purchaser of this product, for the structure in which this product is originally installed, that it is free from defect in materials and/or workmanship for a period of two years from the date of purchase. The proper operation of this product is dependent on your compliance with the instructions regarding installation, operation, maintenance and testing. Failure to comply strictly with those instructions will void this limited warranty in its entirety.

If, during the limited warranty period, this product appears to contain a defect covered by this limited warranty, call 1-800-528-2806, toll free, before dismantling this product. Then send this product, pre-paid and insured, to our service center for warranty repair. You will be advised of shipping instructions when you call. Please include a brief description of the problem and a dated proof-of-purchase receipt with any product returned for warranty repair. Products returned to Seller for warranty repair, which upon receipt by Seller are confirmed to be defective and covered by this limited warranty, will be repaired or replaced (at Seller's sole option) at no cost to you and returned pre-paid. Defective parts will be repaired or replaced with new or factory-rebuilt parts at Seller's sole option.

**ALL IMPLIED WARRANTIES FOR THE PRODUCT, INCLUDING BUT NOT LIMITED TO ANY IMPLIED WARRANTIES OF MERCHANTABILITY AND FITNESS FOR A PARTICULAR PURPOSE, ARE LIMITED IN DURATION TO THE TWO YEAR LIMITED WARRANTY PERIOD SET FORTH ABOVE, AND NO IMPLIED WARRANTIES WILL EXIST OR APPLY AFTER SUCH PERIOD. Some States do not allow limitations on how long an implied warranty lasts, so the above limitation may not apply to you. THIS LIMITED WARRANTY DOES NOT COVER NON-DEFECT DAMAGE, DAMAGE CAUSED BY IMPROPER INSTALLATION, OPERATION OR CARE (INCLUDING, BUT NOT LIMITED TO ABUSE, MISUSE, FAILURE TO PROVIDE REASONABLE AND NECESSARY MAINTENANCE, UNAUTHORIZED REPAIRS OR ANY ALTERATIONS TO THIS PRODUCT), LABOR CHARGES FOR REINSTALLING A REPAIRED OR REPLACED UNIT, OR REPLACEMENT OF BATTERIES.**

**THIS LIMITED WARRANTY DOES NOT COVER ANY PROBLEMS WITH, OR RELATING TO, THE GARAGE DOOR OR GARAGE DOOR HARDWARE, INCLUDING BUT NOT LIMITED TO THE DOOR SPRINGS, DOOR ROLLERS, DOOR ALIGNMENT OR HINGES. THIS LIMITED WARRANTY ALSO DOES NOT COVER ANY PROBLEMS CAUSED BY INTERFERENCE. ANY SERVICE CALL THAT DETERMINES THE PROBLEM HAS BEEN CAUSED BY ANY OF THESE ITEMS COULD RESULT IN A FEE TO YOU.**

**UNDER NO CIRCUMSTANCES SHALL SELLER BE LIABLE FOR CONSEQUENTIAL, INCIDENTAL OR SPECIAL DAMAGES ARISING IN CONNECTION WITH USE, OR INABILITY TO USE, THIS PRODUCT. IN NO EVENT SHALL SELLER'S LIABILITY FOR BREACH OF WARRANTY, BREACH OF CONTRACT, NEGLIGENCE OR STRICT LIABILITY EXCEED THE COST OF THE PRODUCT COVERED HEREBY. NO PERSON IS AUTHORIZED TO ASSUME FOR US ANY OTHER LIABILITY IN CONNECTION WITH THE SALE OF THIS PRODUCT.**

Some states do not allow the exclusion or limitation of consequential, incidental or special damages, so the above limitation or exclusion may not apply to you. This limited warranty gives you specific legal rights, and you may also have other rights which vary from state to state.

### **HOW TO ORDER REPAIR PARTS**

OUR LARGE SERVICE ORGANIZATION  
SPANS AMERICA

FOR INSTALLATION AND SERVICE INFORMATION,  
CALL OUR TOLL FREE NUMBER

**1-800-528-2806**

[www.liftmaster.com](http://www.liftmaster.com)

**WHEN ORDERING REPAIR PARTS  
PLEASE SUPPLY THE FOLLOWING INFORMATION:**

**PART NUMBER DESCRIPTION MODEL NUMBER**

ADDRESS ORDER TO:

THE CHAMBERLAIN GROUP, INC.  
Technical Support Group  
6050 S. Country Club Road  
Tucson, AZ 85706