

ENFORCER®

Long-Range Barrier Sensors

Manual

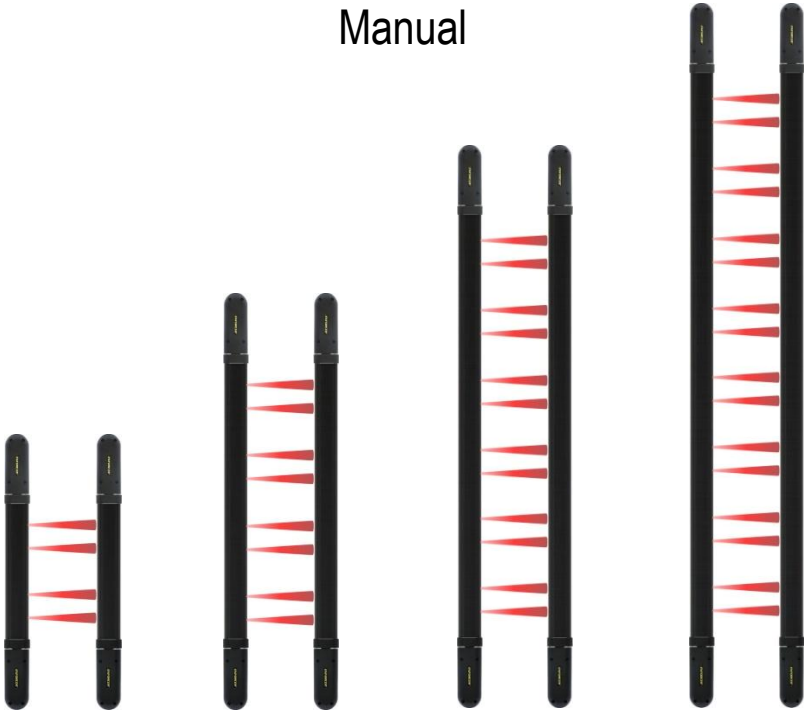

Model	# of Beams	Length
E-9626-2B190Q	2 pairs	26" (66cm)
E-9643-4B190Q	4 pairs	43" (109cm)
E-9661-6B190Q	6 pairs	61" (155cm)
E-9679-8B190Q	8 pairs	79" (201cm)

- 4 Different programmable frequencies
- Range: Up to 190ft (60m) outdoor, 380ft (120m) indoor
- End caps swivel for easy installation
- Built-in heater for cold weather operation
- Built-in tamper switches
- Programmable trigger options
- Form C relay output
- Weatherproof IP65
- AGC circuits ensure operation in rain, fog, and low-temperature conditions

SLI SECO-LARM



Note: Model numbers that end with "Q" or that have a round green "Q" sticker signify RoHS-compliant products.

Table of Contents:

Introduction.....	2	Connecting Multiple Units	7
Parts List	2	Installation – Running the Wires.....	8
Features	3	Installation – Mounting	8
Specifications	3	Installation – Connecting the Wires	9
Dimensions.....	4	Aligning the Beams	10
Swivel Housing.....	4	Programming the Trigger Mode	10
Sample Applications	4	Programming the Barrier Sensor.....	11
Overview – Inside the Sensor.....	5	Triggering the Barrier Sensor.....	11
Installation – Choosing a Location.....	6	Troubleshooting	12
Installation – Wall vs. Pole Mounting.....	7		

Introduction:

ENFORCER Long-Range Barrier Sensors are ideal for protecting indoor or outdoor areas separated by long distances. They feature reliable photobeam technology with a choice of four programmable beam frequencies that provide superior perimeter protection by eliminating crosstalk and interference when multiple units are used. False alarms caused by animals, falling leaves, poor weather, or other sources are minimized by programming the alarm output trigger operation.

ENFORCER Long-Range Barrier Sensors work in even the most extreme conditions. A built-in heater automatically turns on and off depending on the outside temperature. An environmental control system senses a slow degradation in beam strength when weather conditions worsen to help prevent false alarms.

Installation and alignment is quick and easy with the ENFORCER Long-Range Barrier Sensors. They come with swiveling heads that allow them to be mounted along the same wall or on opposite walls, as well as provide for easy alignment of the beams between the transmitter and receiver.

Parts List:

- 1 x Transmitter
 - 1 x Receiver
 - 1 x Manual
 - 4 x Pole mount brackets
 - 8 x Machine screws 4x6mm (for pole mount brackets)
 - 8 x Machine screws 4x25mm (for pole mount brackets)
 - 12 x Screws 6x20mm (for wall mount use)
 - 12 x Plastic anchors (for wall mount use)
-

Features:

- For indoor or outdoor perimeter security
- Long sensor range up to 190ft (60m) outdoors, 380ft (120m) indoors
- Install on windows, doorways, skylights, fence tops, and any place where space is limited
- End caps swivel so sensor can be mounted on a single wall or on opposite walls with no L-bracket needed
- Programmable immediate trigger on simultaneous breaking of beams, or trigger after a single pair of beams is broken for at least 2 seconds
- Heater for use in cold weather operation
- Heater activates at 41°F (5°C)
- Terminal block wiring
- Slim design: 2 1/4" x 1 7/8" (55 x 49 mm)
- Rugged aluminum construction
- Built-in tamper switches, one on either end, trigger the alarm if end cap is removed
- No synchronizing wires required to align the beams
- Form C relay output
- LED and buzzer alignment indicators
- AGC (Auto Gain Control) circuits regulate beam signals in order to compensate for and ensure operation in rain, fog, and low-temperature conditions
- Programmable for 4 different frequencies to reduce interference between multiple units

Specifications:

Model	E-9626-2B190Q	E-9643-4B190Q	E-9661-6B190Q	E-9679-8B190Q
Number of beams	2 pairs	4 pairs	6 pairs	8 pairs
Max. range (outdoor)	190' (60m)			
Max. range (indoor)	380' (120m)			
Tx standby & active current, heater off (+/-25%@12VDC)	56mA	84mA	100mA	109mA
Rx standby current (buzzer off), heater off (+/-25%@12VDC)	66mA	80mA	95mA	108mA
Rx trigger current (buzzer on) heater off (+/-25%@12VDC)	66mA	80mA	95mA	108mA
Buzzer active current (Rx only)	20mA@12VDC			
Heater active current (Rx+Tx)	160mA@12VDC			
Input voltage	12-24 VDC			
Response time (receiver)	150/300/450/600 ms (DIP switch programmable)			
Detection methods	Triggers as programmed when any 2 adjacent pair of beams are broken, or any single pair of beams is broken for over 2 sec. (programmable by JP2)			
Selectable beam frequencies	4 Different frequencies (DIP switch programmable)			
Alarm output	NO/NC/COM, relay output, active for 1 sec. when triggered			
Tamper output (Tx & Rx)	1A@120VAC / 1A@24VDC			
Alignment LED (Rx only)	Red LED, ON – beam is broken / OFF – aligned			
Alignment angle	Horizontal +/-90°			
Operating temperature	-45°C~-55°C (-49°F~-131°F)			
Humidity	95%			
Ingress protection	IP65			
Case	Aluminum housing / PC anti-UV cover / ABS end caps			
Dimensions	See page 4, <i>Dimensions</i> for more details			
Weight (Tx & Rx) with brackets	5.5lb (2.5kg)	7.7lb (3.5kg)	12.1lb (5.5kg)	14.3lb (6.5kg)

Dimensions:

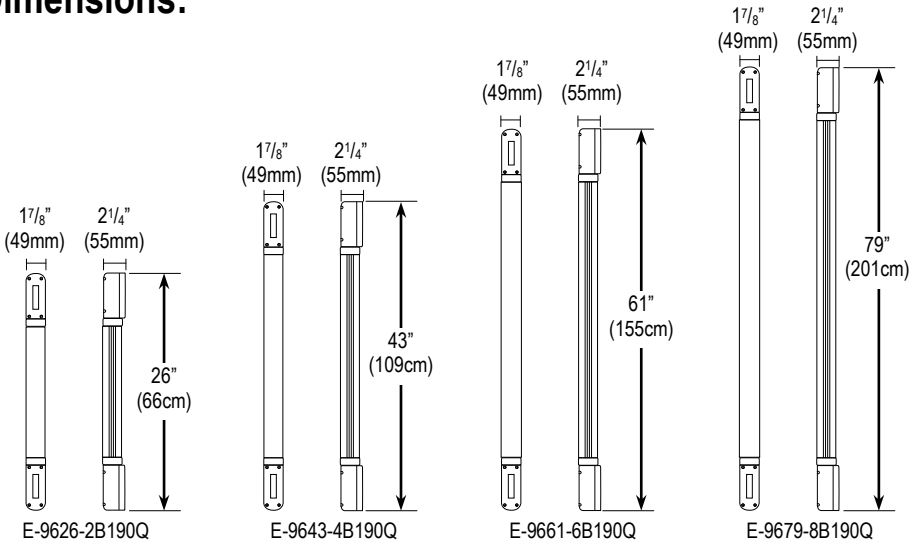

Swivel Housing:

Each sensor is built with a swivel housing for flexible installations and simple alignment. To use, twist the beams up to 90°.

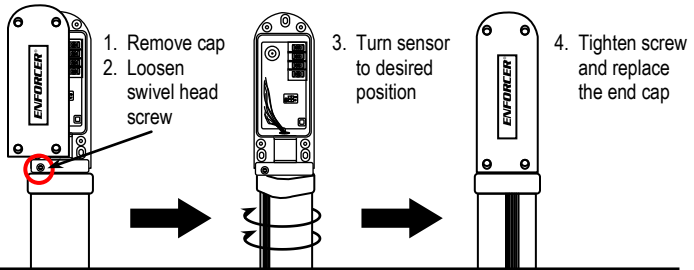

Sample Applications:

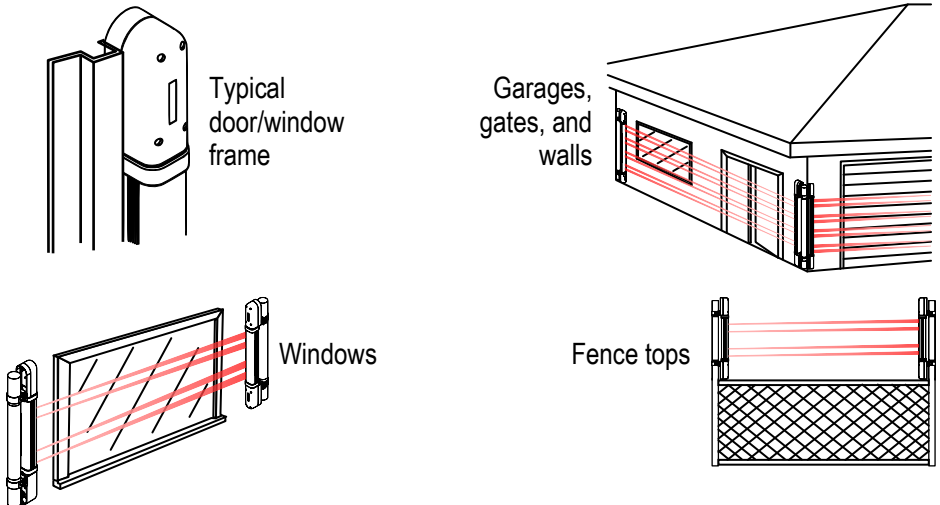

Overview – Inside the Sensor:

Transmitter

Receiver

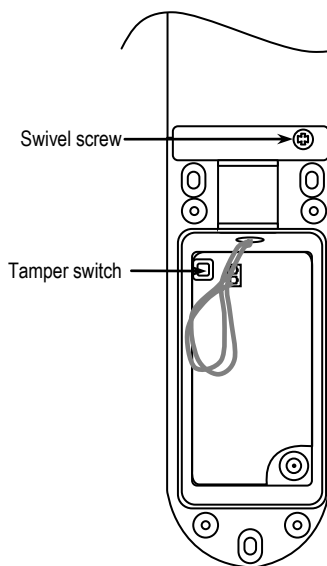
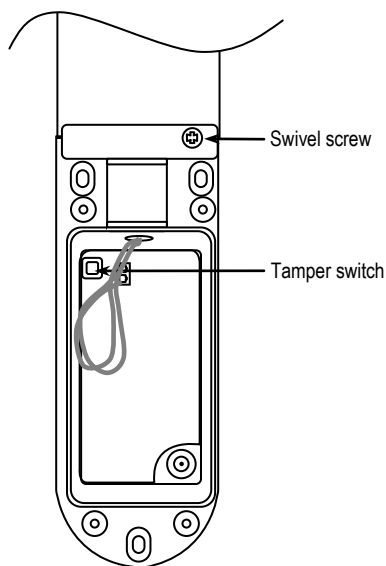
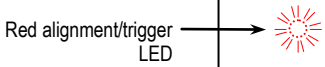
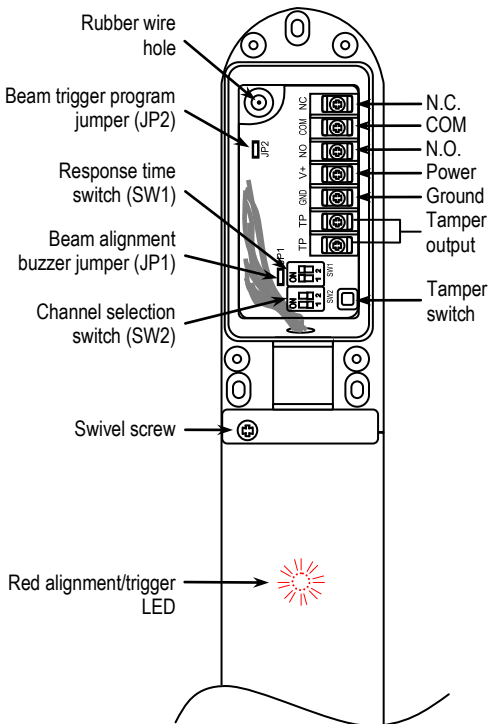
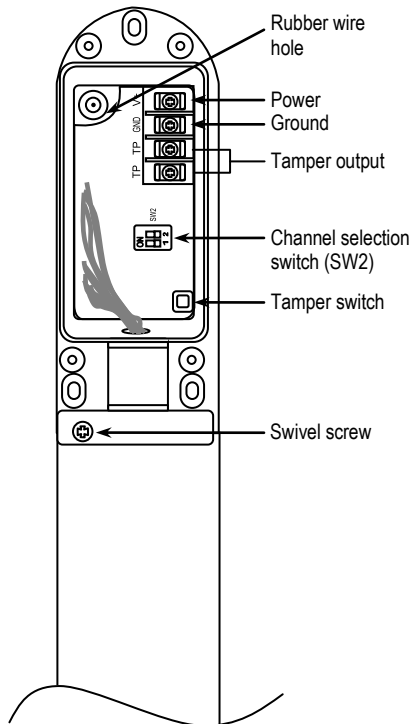

Installation – Choosing a Location:

IMPORTANT: Do not connect to power until the sensor has been completely installed and the installation has been double-checked.

When used outdoors, place the Long-Range Barrier Sensor under a roof or shelter. This will reduce the chance of false alarms caused by rain or snow.

To prevent erratic operation and/or false alarms:

- Do not mount near trees, bushes or other leafy vegetation. Wind could cause leaves or similar objects to fly or wave into the beams (see Fig. 1).
- Do not mount where water might run off the roof and break the beam (see Fig. 1).
- Do not mount where the units could be splashed by water or mud.
- Do not let sunlight or any direct beam of light shine directly on the sensor. If unavoidable, mount in a way that the transmitter – not the receiver – faces the sun (see Fig. 2).
- Mount the sensor so that the wires are placed at the bottom. If the wires must be placed on top, seal the opening with silicone.
- Do not mount in such a way that the terminal block of one unit is at the top and the other is at the bottom (see Fig. 3).
- Do not mount where animals or other objects could accidentally break the beams.
- Do not mount near reflective surfaces, as this could prevent the sensor from working properly.
- Do not mount where the unit could be suddenly exposed to a bright light, such as a floodlight or a passing automobile's headlight.

Fig. 1 – Beware natural interference

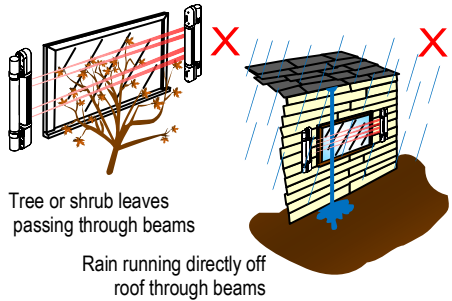
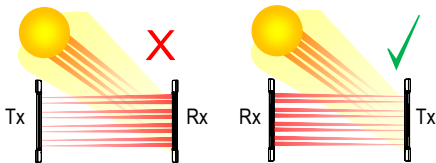
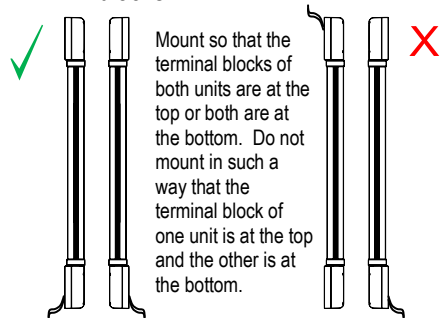

Fig. 2 – Orientation to the sun



Do not let sunlight or any direct beam of light shine directly on the sensor. If unavoidable, mount in a way that the transmitter – not the receiver – faces the sun.

Fig. 3 – Orientation of the terminal blocks



Installation – Wall vs. Pole Mounting

Fig. 4 – Wall mounting – Same wall

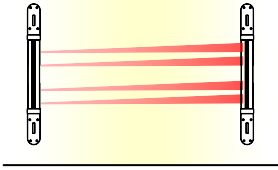

Fig. 5 – Wall mounting – Facing walls

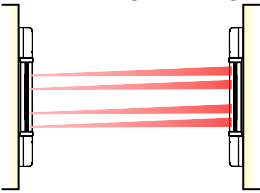
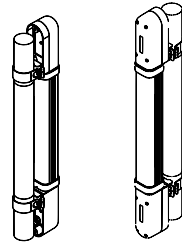
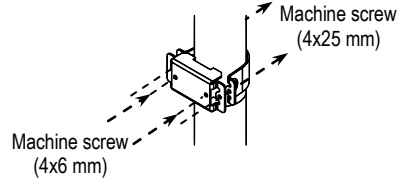

Fig. 6 – Pole mounting



(Pole-mount brackets included)

Connecting Multiple Units

Fig. 7 – Linear protection

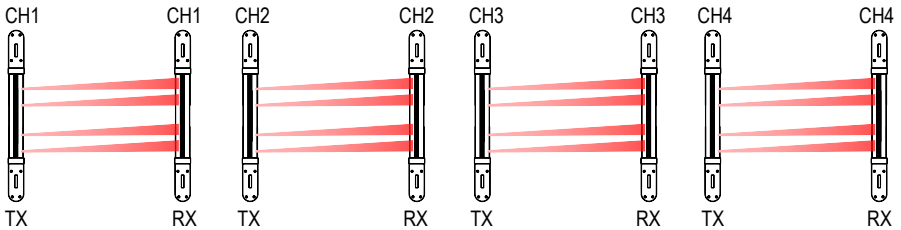
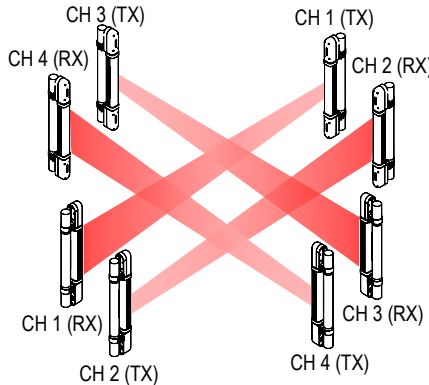

Fig. 8 – Perimeter protection



Installation – Running the Wires

1. Run six wires (1 x power, 1 x ground, 2 x alarm signal, and 2 x tamper switch) from the alarm control panel to the receiver of the sensor. Shielded cable is strongly suggested.
2. Run four wires (1 x power, 1 x ground, and 2 x tamper switch) from the alarm control panel to the transmitter of the sensor. Shielded cable is strongly suggested.

Note: It may be more convenient to connect the transmitter's power and tamper wires to the receiver's power and tamper wires.
3. If burying the wires is required, make sure to run them through electrical conduit. Shielded cable is strongly suggested.
4. If the wires are run along the wall, the use of armored cable is strongly suggested.

Fig. 9 – Maximum wire lengths

Voltage	Gauge	Max. length
12VDC	AWG 22	1,800ft (550m)
12VDC	AWG 20	2,600ft (800m)
24VDC	AWG 22	2,600ft (800m)
24VDC	AWG 20	3,900ft (1,200m)

Installation – Mounting

1. Find a suitable location.
 - a. The transmitter and receiver can be mounted at any angle as long as they are parallel to each other and directly facing each other, and as long as the wires come out of the same ends of both units (see Fig. 3).
 - b. If using multiple curtain sensors, be sure to set each for a different frequency (see pg. 11).
 - c. The transmitter and receiver must not be separated by more than 190ft (60m) outdoors or 380ft (120m) indoors.
2. Mount the transmitter and the receiver in such a way that surface-mounted wires do not come out from above the units. This is to prevent water from entering via the wire holes. If this is unavoidable, use silicone to completely cover the area where the wires come out the holes to prevent water from entering
3. Once a suitable mounting location has been found, remove the covers of the end caps and locate the three mounting holes (see Fig. 10). Using these holes as a template, mark their location on the wall with a pencil.
4. Connect the wires (see pg. 9) before permanently mounting the units to the wall.

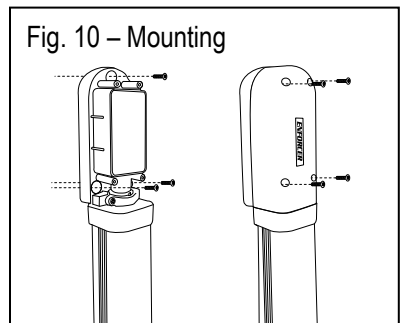

Installation – Connecting the Wires

Receiver

1. Unscrew and pull the end cap off the side of the receiver with the terminal block (see Fig. 11).
2. Run the wires through the rubber wire hole in the top corner of the back of the end cap.
3. Program the receiver (see pg. 11).
4. Replace the end cap. **NOTE:** End cap must be off when aligning the sensor.
5. Use a screwdriver to tighten the screws holding the end cap in place.

Transmitter

1. Unscrew and pull the end cap off the side of the transmitter with the terminal block (see Fig. 12).
2. Run the wires through the rubber wire hole in the top corner of the back of the end cap.
3. Program the transmitter.
4. Replace the end cap. **NOTE:** End cap must be off when aligning the sensor.
5. Use a screwdriver to tighten the screws holding the end cap in place.

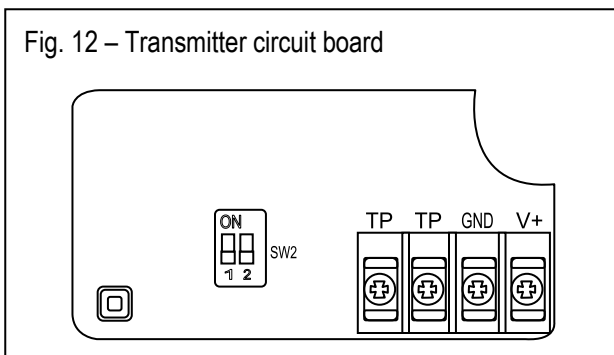
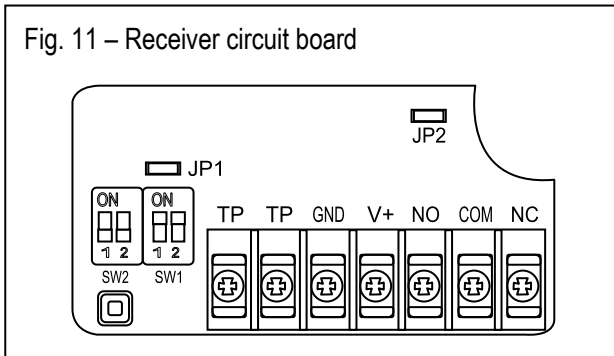

Aligning the Beams

1. To align the beams, loosen the swivel screw and adjust the beams to face each other. Connect the power to the receiver and transmitter. If the beams are not aligned, the red LED on the receiver will light ON (see Fig. 13).
2. For audible confirmation in addition to the LED, make sure jumper JP1 is plugged in on the receiver's circuit board. If the beams are not aligned, the receiver's buzzer will sound. To disable this feature, remove JP1 (see Fig. 14).
3. Once the beams are aligned, the red LED will turn off and the buzzer will not sound.

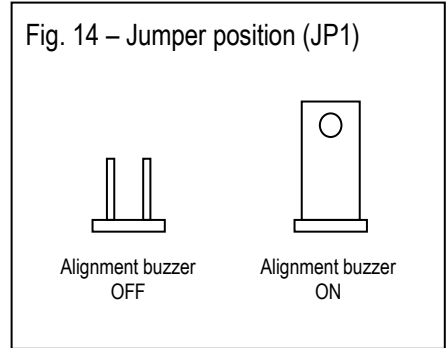
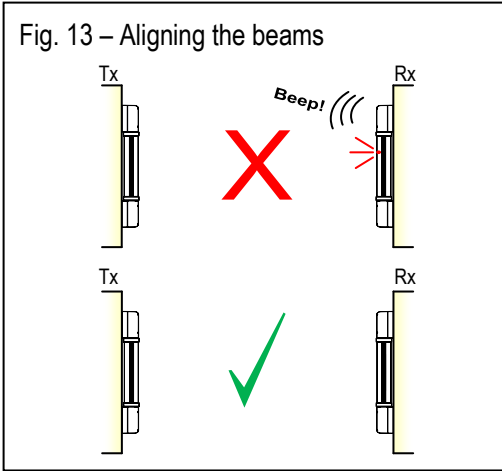

Programming the Trigger Mode

1. The default detection method is when any 2 adjacent pair of beams is broken, or when any single pair of beams are broken more than 2 seconds (see Fig.19).
2. The latter (any single pair of beams broken) detection function can be disabled when the JP2 jumper is removed.

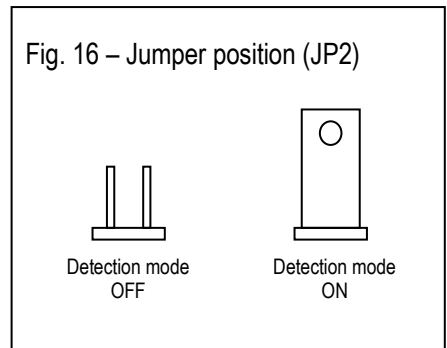
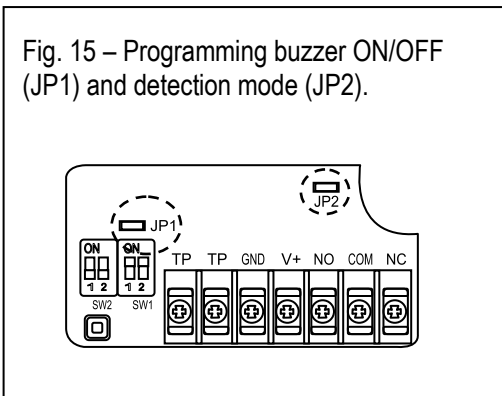

Programming the Barrier Sensor

Fig. 17 – Programming the response time (SW1)

Receiver circuit board

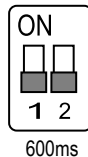
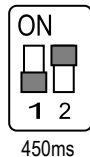
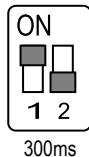
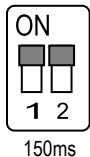
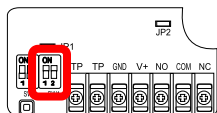
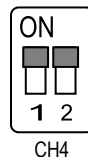
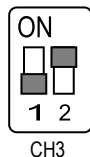
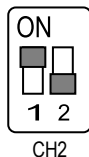
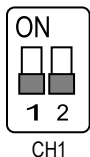
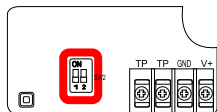
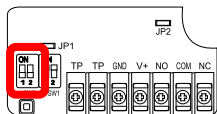

Fig. 18 – Programming the sensor beam channel frequency (SW2)

Transmitter circuit board



Receiver circuit board



Triggering the Barrier Sensor

Fig. 19 – Ways to trigger the sensor

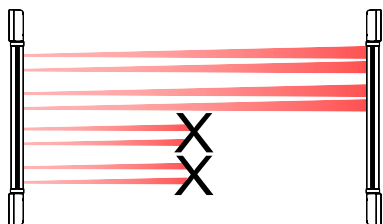

Any two adjacent pair tripped
Response time: programmable
150/300/450/600ms

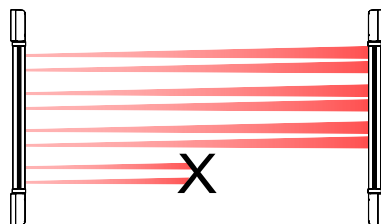

Any single pair tripped
Response time: 2 seconds
(Programmable, see page 10)

Troubleshooting:

Receiver LED never turns ON and the buzzer never sounds	<ul style="list-style-type: none">• Test the power and ground wire with a voltage meter to ensure power is connected and is of the correct voltage
Buzzer does not sound if the sensor is triggered	<ul style="list-style-type: none">• If jumper J1 is plugged in, this indicates that the beams are not aligned• If jumper J1 is not plugged in, buzzer should never sound
Receiver LED is ON and the buzzer sounds all the time	<ul style="list-style-type: none">• Realign the transmitter and receiver
Does not trigger when beam is broken	<ul style="list-style-type: none">• Remount the curtain sensor, or repaint the surface to cut down on reflection• Lower the response time (SW1)
Receiver continuously triggers the alarm	<ul style="list-style-type: none">• Realign the transmitter and receiver• Check that the tamper switch and the cover for the tamper switch are mounted correctly
False alarm	<ul style="list-style-type: none">• Reinstall so that one sensor does not interfere with another sensor• Cut back on leafy vegetation• Do not mount under the edge of the roof• Mount under a roof or shelter

Also Available from SECO-LARM:

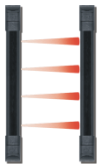

Curtain Beam Sensors



Dual Beam Sensors



Quad Beam Sensors



Retro-Reflective Beam Sensors

WARRANTY: This SECO-LARM product is warranted against defects in material and workmanship while used in normal service for a period of one (1) year from the date of sale to the original customer. SECO-LARM's obligation is limited to the repair or replacement of any defective part if the unit is returned, transportation prepaid, to SECO-LARM.

This Warranty is void if damage is caused by or attributed to acts of God, physical or electrical misuse or abuse, neglect, repair or alteration, improper or abnormal usage, or faulty installation, or if for any other reason SECO-LARM determines that such equipment is not operating properly as a result of causes other than defects in material and workmanship.

The sole obligation of SECO-LARM and the purchaser's exclusive remedy, shall be limited to replacement or repair only, at SECO-LARM's option. In no event shall SECO-LARM be liable for any special, collateral, incidental, or consequential personal or property damages of any kind to the purchaser or anyone else.

NOTICE

The information and specifications printed in this manual are current at the time of publication. However, the SECO-LARM policy is one of continual development and improvement. For this reason, SECO-LARM reserves the right to change specifications without notice. SECO-LARM is also not responsible for misprints or typographical errors.

Copyright © 2012 SECO-LARM U.S.A., Inc. All rights reserved. This material may not be reproduced or copied, in whole or in part, without the written permission of SECO-LARM.

SECO-LARM U.S.A., Inc.

16842 Millikan Avenue, Irvine, CA 92606

Tel: 800-662-0800 / 949-261-2999

Website: www.seco-larm.com

E-mail: sales@seco-larm.com

 PITSW3

MI E-96xx-xB190QXX_1107.docx