

DSP-222 Operations Manual

Dual Channel Inductive Loop Detector Sensor Unit



This manual contains technical information for the DSP-222 detector sensor unit. Included are general description, general characteristics, installation procedure, adjustment instructions, operational guide, maintenance procedures and technical schematics and drawings.

1. General Description

The DSP-222 is a dual-channel inductive loop vehicle detector sensor unit designed to meet the State of California, Department of Transportation, (Caltrans) specification TSCES dated January of 1989 and the addendum dated July of 1991.

2. General Characteristics

The sensor unit incorporates a double-sided 44-pin edge connector for the connection of power, loop inputs and call outputs and sensor unit reset. Each channel has individual front-panel controls for setting sensitivity, frequency, and pulse/presence mode. Each channel is also equipped with two high-intensity front-panel LEDs which are used to indicate the detect state and fail condition of the individual channels. Call outputs are optically isolated solid-state transistors. The sensor unit occupies one position of a standard 170 input file. Each channel of the DSP-222 will automatically tune to any loop and lead-in inductance between 50 and 750 microhenries with a loop system "Q" as low as 5. The unit will detect inductance changes as small as 0.01% $\Delta L/L$.

3. Installation and Adjustments

The sensor unit is factory shipped with all switches set to off signifying both channels are disabled. The MIN PRESENCE jumper J1 located on the printed circuit board is installed forcing all detection outputs to last a minimum of 100 ms in the presence mode. The ALTERNATE jumper J2 located on the printed circuit board is installed forcing both channels to operate in the non-scanning mode.

- a) Remove the MIN PRESENCE jumper J1 on the circuit board to allow presence outputs of times less than 100 ms, if so desired.
- b) Remove the ALTERNATE jumper J2 on the circuit board to allow both channels to scan sequentially, if so desired.
- c) Make sure that the sensor unit is firmly seated into its position in the input file.
- d) Set the PULSE switch on for pulse operation. Set the PULSE switch off for presence operation.
- e) Adjust sensitivity by setting switches S1, S2, and S4 to the desired position using standard binary coding. Sensitivity 1 is the lowest setting and Sensitivity 7 is the highest

setting. If a channel is not used, it may be switched off (disabled) by setting it to Sensitivity 0 (all three switches off).

f) Frequency setting needs to be changed only if crosstalk occurs between nearby loops. Crosstalk usually manifests itself as chattering of the call output. Change the frequency if crosstalk is encountered. Four frequency positions are available on each channel to assist in alleviating interference. It may be necessary to reset the channel after the frequency has been changed.

g) Check the front-panel indicators. If the Fault LEDs on either channel are flashing there is a problem with the loop system on that channel. Observe the flash sequence to determine the type of fault. A single flash followed by a pause indicates an open loop system. A double flash indicates a shorted loop system. Check the loop connections carefully. Reset both channels by momentarily selecting a different sensitivity or mode and then return to the original setting.

h) Monitor operation and make adjustments to the sensitivity and frequency as necessary.

4. Theory of Operation

The DSP-222 works on the principle that loop frequency is directly related to loop inductance. However, the change in loop frequency is very small -- perhaps as little as one hertz. It is easy to measure a change of one hertz simply by counting the number of cycles in one second. Unfortunately, the minimum response time using this method is easily greater than one second. To improve the response time, the measurement is done by gating a high-speed stable oscillator with the loop frequency. This scheme, called period measurement, provides high-resolution in a short period of time. This measurement is compared to a previously established reference to determine whether or not the frequency of the loop oscillator has changed sufficiently to indicate the presence of a vehicle.

The high speed of the reference crystal oscillator ensures that the sample can be taken within a very short period of time. For example, at sensitivities less than 4, a sample can be taken within 2 ms which allows the sensor unit to respond to a vehicle presence (or loss of presence) in the detection area with an accuracy of 1 ms. Note: This is true only if the ALTERNATE jumper J2 is installed.

Sensitivity is a function of how long a sample is used for the determination of a vehicle presence, i.e. the longer the sample time, the more sensitive the sample. Since the sensor unit measures the minute changes in loop oscillations, it follows that low frequency loops are innately more sensitive than high frequency loops. In order to keep

the sensitivity the same over the wide spectrum of loop frequencies, the sensor unit first measures the loop frequency and calculates the number of complete cycles needed for a sample. This value is then used for all subsequent loop measurements for this channel.

The sensor unit checks the completed sample to confirm that it is still within acceptable operating limits and then determines whether the sample has changed sufficiently with respect to the stored reference to indicate the presence of a vehicle. It then controls the output and indicators appropriately. Minor changes in period occurring over a relatively long time are due entirely to environmental fluctuations. By altering the stored reference slowly, these environmental changes are ignored. In this fashion, the sensor unit can compensate for temperature changes and other long-term effects such as water on the pavement.

5. Detailed Description of Circuit Operation

The following description is valid for both channels of the DSP-222. Reference designators are shown for channel 1 with those related to channel 2 in parentheses. Refer to section 8 for block diagram and schematic.

The loop oscillators consist of two PNP transistors in a basic Franklin type circuit. Q1 (Q4) is coupled to Q2 (Q5) to form the active oscillator. The loop is connected to the oscillator circuit with the isolation transformer T1 (T2). The reflected roadway loop inductance is resonated with the capacitor C5 (C11). Frequency modification capacitors C3 (C9) and C4 (C10) are switched in via SW1 (SW2) and are used to change the operating frequency of the loop circuit. Neon surge arrestor I1 (I2) provides high voltage spike protection. When loops are connected to the oscillators and the unit is under power, the oscillators will resonate at their natural frequency according to the inductance of the roadway loop and the capacitance described above.

Surge protective diode D1 (D2) is used to limit voltage surges that may appear on the circuit side of the loop transformer. The output signal from the oscillator is present on the collector of Q1 (Q4) and is a sine wave at the oscillator frequency.

The loop frequency signals from the oscillators are routed to the squaring circuits formed by transistor Q3 (Q6). The outputs of the squaring circuits are passed through a low-pass filter network consisting of resistor R9 (R18) and capacitor C6 (C12). From here, the square wave loop frequency is presented to the capture register input of the microprocessor.

The Microchip PIC 16F73 U1 is an advanced RISC microcontroller using Harvard architecture. The processor is being clocked with a 20 MHz crystal. This speed insures fast instruction processing as well as a high-speed time base for the two independent capture registers used in the period measurement of the loop frequencies.

The front-panel LED indication LED2 (LED1) is used to indicate the “Call” output of the channels. LED3 (LED4) indicates the “Fail” condition of the loops. These outputs are driven directly by the microcontroller. Monolithic voltage regulators provide a stable 12-volt reference supply U3. Two additional 5-volt regulators provide stable 5-volt power to the digital circuitry U2 and loop oscillators respectively U4.

An external reset signal is provided to reset the microcontroller with a low (ground true) signal on pin C of the loop sensor unit. This is accomplished by using Q9 as an input voltage comparator and phase inverter as well as a second phase inverter Q10. The input signal is “noise” filtered with C15 and diode D5.

Front-panel switch S1 (S2) is used to input data to the microcontroller from the user. The sensitivity setting and the choice of pulse or presence operation are routed directly to the input ports of the microcontroller U1.

Transistor Q7 (Q8) is the high-current driver necessary to power the opto-isolator U5 outputs for external equipment.

The +24 volt input is protected with a power diode D6 to prevent damage to the unit if power is connected incorrectly. In addition, an input resistor R36 is provided to reduce inrush current when the unit is plugged into a “hot” card cage. The input voltage is well filtered with C16.

6. Preventive Maintenance

Over the years, the electronic components used in inductive loop detectors have become very reliable. Generally, most inductive loop sensor problems can be traced to the loop system. The loop system is defined as the loop of wire(s) located in the street, the lead-in wire(s) located between the street loop and the controller cabinet, and the associated wiring in the controller cabinet itself.

The wire used in the street loop should be rated for direct burial. The wire should be of the cross-linked polyethylene (XLPE) insulated type. PVC insulated type of wire should always be avoided. The sealant should be carefully chosen to match the application and pavement. A hard setting epoxy should never be used with asphalt.

The loop wires should be held into the bottom of the saw cut with backer rod. The loop wire should be twisted with a minimum of 5 twists per foot between the loop itself and the splice point. This is usually the hand hole or pull box at the side of the road.

At this point, the twisted loop wires must be soldered to the lead-in cable. If crimp type connectors are used, they must be soldered after crimping. After soldering, the splices must be protected with a moisture-proof seal.

The feeder cable used to extend the lead-in, must be a shielded, twisted pair with high-density polyethylene insulation. The termination of the feeder cable in the controller cabinet must also be soldered if crimp type terminals are used. The use of wire nuts and other improper methods of connections will result in problems with the detection system.

7. Trouble Analysis

The following chart should be used to troubleshoot the sensor unit and installation. If the DSP-222 itself is suspect, see section 8 for a complete internal testing sequence.

a) Neither channel responds to vehicles. Power supply fault.

The DSP-222 requires a 24 VDC nominal supply. The sensor unit will operate at voltages as low as 16 volts. However, supply voltages below this may result in the sensor unit entering a reset state. In this case, the unit will appear to be non-functional.

b) Reset line held low.

This fault is likely to affect all units in the rack since the external reset line is usually common to every card rack position. Measure the voltage on the external reset line. If it is below approximately 12 volts, remove each unit one by one until the reset line returns to the power supply level (approximately 24 volts). The unit that was removed last should be checked carefully for other faults. See section 8.

c) Channel does not detect all vehicles.

Sensitivity is too low. Increase sensitivity by one setting and observe operation.

d) Channel is noisy/chatters/gives false detect calls.

Two or more units are interfering with each other (crosstalk). Adjust the frequency switches on all units that exhibit crosstalk. Continue this procedure until all affected channels are corrected.

8. Troubleshooting Sequence

Apply 24 ± 1 volt power to the unit. Connect a loop test box with an inductance of approximately 115 microhenries to the loop inputs pins D and E (channel 1) and pins J and K (channel 2) to simulate the connection of loops.

NOTE: All of the following signal measurements are referenced to logic ground.

a) Unregulated power supply.

Voltage across capacitor C16 should be 24 ± 1 volt. This voltage can also be measured at the input of regulator U3 and/or U2.

Possible component faults are diode D6 or resistor R36.

b) Regulated 12 volt power supply.

Voltage at output of U3 (across capacitors C17) should be $12 \pm .2$ volts. Possible component fault is the voltage regulator U3.

c) Regulated 5 volt (logic) power supply.

Voltage at output of U2 should be $5 \pm .2$ volts.

Possible component fault is the voltage regulator U2.

d) Regulated 5 volt (oscillator) power supply.

Voltage at output of U4 should be 5 ± 0.2 volts.

Possible component fault is the voltage regulator U4.

e) Microcontroller clock

Waveform at pin 10 of U1 should be a sine wave at 20 MHz with a peak to peak voltage of 1 to 2 volts. Note: This value will vary with the type of oscilloscope probe used. The value stated here is obtained using a Tektronix scope probe with a capacitance of 20 pF.

Possible components at fault are the crystal X1 or microcontroller U1.

f) Reset input to microcontroller

Voltage at pin 1 of U1 should be 5 volts \pm .2 volts. Check to insure pin C on the detector is high--approximately 24 volts.

Possible components at fault are transistors Q9, Q10, or diode D5.

g) Loop oscillator output

Connect an oscilloscope to pin 13 (pin 12) of U1. Observe the square wave to be the same frequency as the loop oscillator. At this point, a simulated call should be introduced at the test box. Observe a slight frequency increase at this point.

If there is no square wave at this point a defective component in the oscillator circuit may exist. Possible components at fault are Q1 (Q4), Q2 (Q5), Q3 (Q6), D3 (D4) or the potcore isolation transformer T1 (T2).

h) Outputs and indicators

Verify that the opto-isolated outputs conducts only when the front-panel detect LEDs are on.

Possible fault areas are: Transistor Q7 (Q8) or the dual opto-isolator U2 or LED2 (LED1)

9. Bill of Materials

Qty	Reference	Description	Manufacturing Part Number
2	C13, 14	22 pF 50V NPO SMD 805	Panasonic/ECU-V1H22OJCN
2	C6, 12	270 pF 50V X7R SMD 805	Kemet/C805C271M5RAC
2	C2, 8	.001uF 50V NPO SMD 805	Panasonic/ECU-V1H102JCX
10	C1,7,15,17-20,22-24	1uF 50V X7R SMD 1206	Kemet/C1206C104M5RAC
2	C3, 9	.022uF 50V PPS 1910	Panasonic/ECH-U1H223JB5
2	C4, 10	.047uF 50V PPS 1812	Panasonic/ECH-U1H473JB9
2	C5, 11	.1uF 50V PPS 1913	Panasonic/ECH-U1H104JB9
2	C25,26	.47uf X7R SMD 1206	AVX 12063C474KAT2A
2	C16, 21	220uF 35V elect SMD	Elna/RV-35V221MH10-R
1	_____	DSP-222 alum. front panel	Diablo P/N CAS013
1	_____	Oscillator plastic cover	Modar/JIT minibox
2	J1, 2	2 pins .025" sq. x .1" center	generic
7	D3-5, 7-10	1N914 SMD SOT-23	Motorola MMBD914LT1
1	D6	1N4004 1 amp 400V SMD SMA	Diodes, Inc S1G-13
2	Z1, 2	33V zener SMD SOD-123	Diodes, Inc MMSZ5257B
2	D1, 2	11V transorb SMD SMB	Diodes, Inc SMBJ11CA
2	LED3, 4	Right angle green LED	Bivar/H101CSGC
2	LED1, 2	Right angle red LED	Bivar/H101CSRC
2	I1,2	NE-2E neon indicator	Xenell
2	_____	#4-3/8" Phil self-tap screw	generic
2	_____	#4-40 5/16" screw w/ washer	generic
2	_____	Right angle bracket	Diablo P/N HDW025
1	_____	Handle	Diablo P/N HDW030
2	_____	#6-3/8" Phil self-tapping screw	generic
2	U2, 4	+5V regulator SMD D2PAK	On Semi M7805CD2T
1	U3	+12V regulator SMD D2PAK	On Semi M7812CD2T
1	U5	Dual opto-coupler SMD SO-8	Fairchild MOC223
1	U1	PIC microcontroller	Microchip PIC16F73-20/SO
1	_____	2-channel oscillator box label	Diablo LBL032
1	_____	Front panel label	Diablo LBL037
1	_____	DSP-222 main PCB	Diablo PCB222
2	R1, 10	68 ohm 1/8 watt SMD 1206	generic
1	R36	10 ohm 1/2 watt SMD 1206	generic
6	R9, 18, 24, 25, 39, 40	330 ohm 1/8 watt SMD 1206	generic
2	R2, 11	510 ohm 1/2 watt SMD 1206	generic
6	R20-23, 37, 38	1K 1/8 watt SMD 1206	generic
16	R3, 5, 7, 8, 12, 14, 16, 17, 26-29, 31, 32, 34, 35	4.7K 1/8 watt SMD 1206	generic
4	R19, 30, 33, 41	12K 1/8 watt SMD 1206	generic

2	R4, 13	27K 1/8 watt SMD 1206	generic
2	R6, 15	56K 1/8 watt SMD 1206	generic
7	Q3, 6-8, 10-12	2N3904 NPN SMD SOT-23 transistor	Motorola MMBT3904LT1
5	Q1, 2, 4, 5, 9	2N3906 SMD SOT-23 transistor	Motorola MMBT3906LT1
2	S1, 2	6 position right angle DIP switch	Switronic DA06BTS
2	T1, 2	Potcore isolation transformer	Diablo P/N XFM060
1	X1	20 Mhz Xtal-parallel 20 pF HC-49UA	Fox 200-20-1

10. Block Diagram

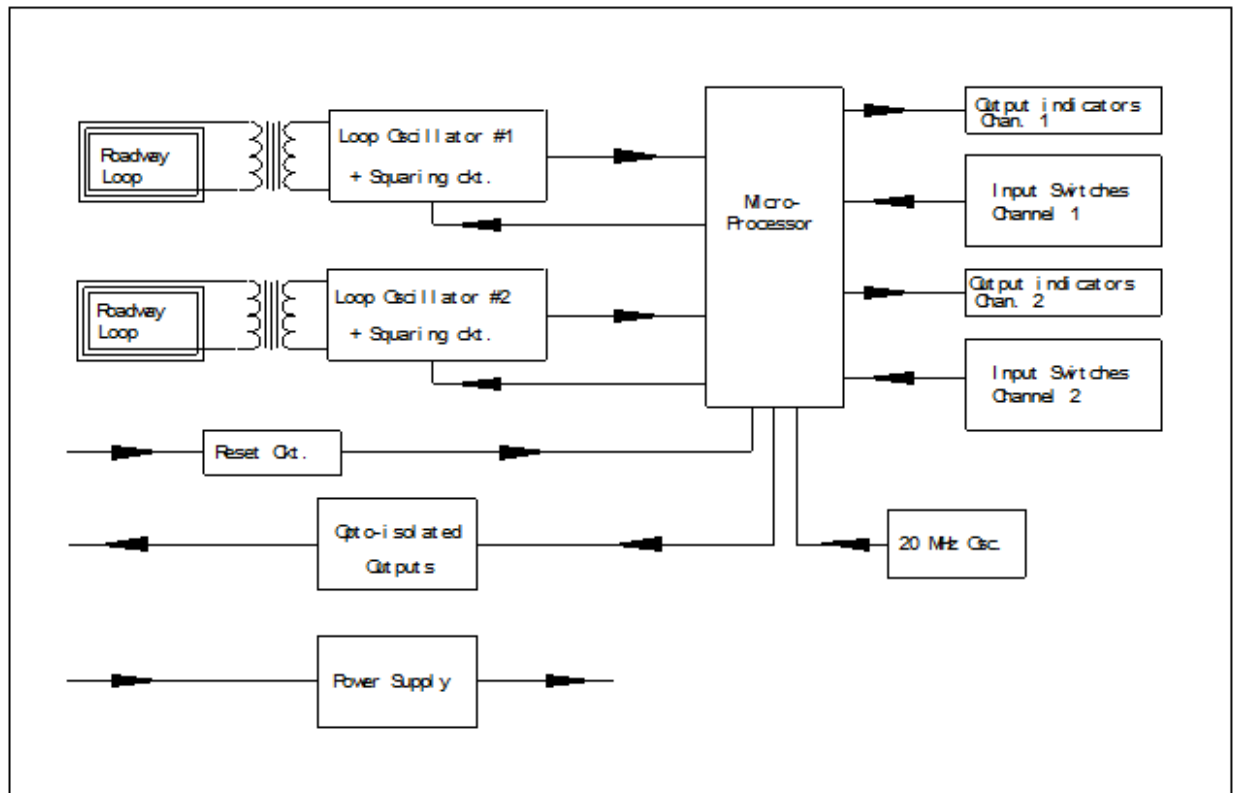

11. Schematic (next page)

This page left intentionally blank.

Remove and insert B-size schematic.

12. Assembly Drawing

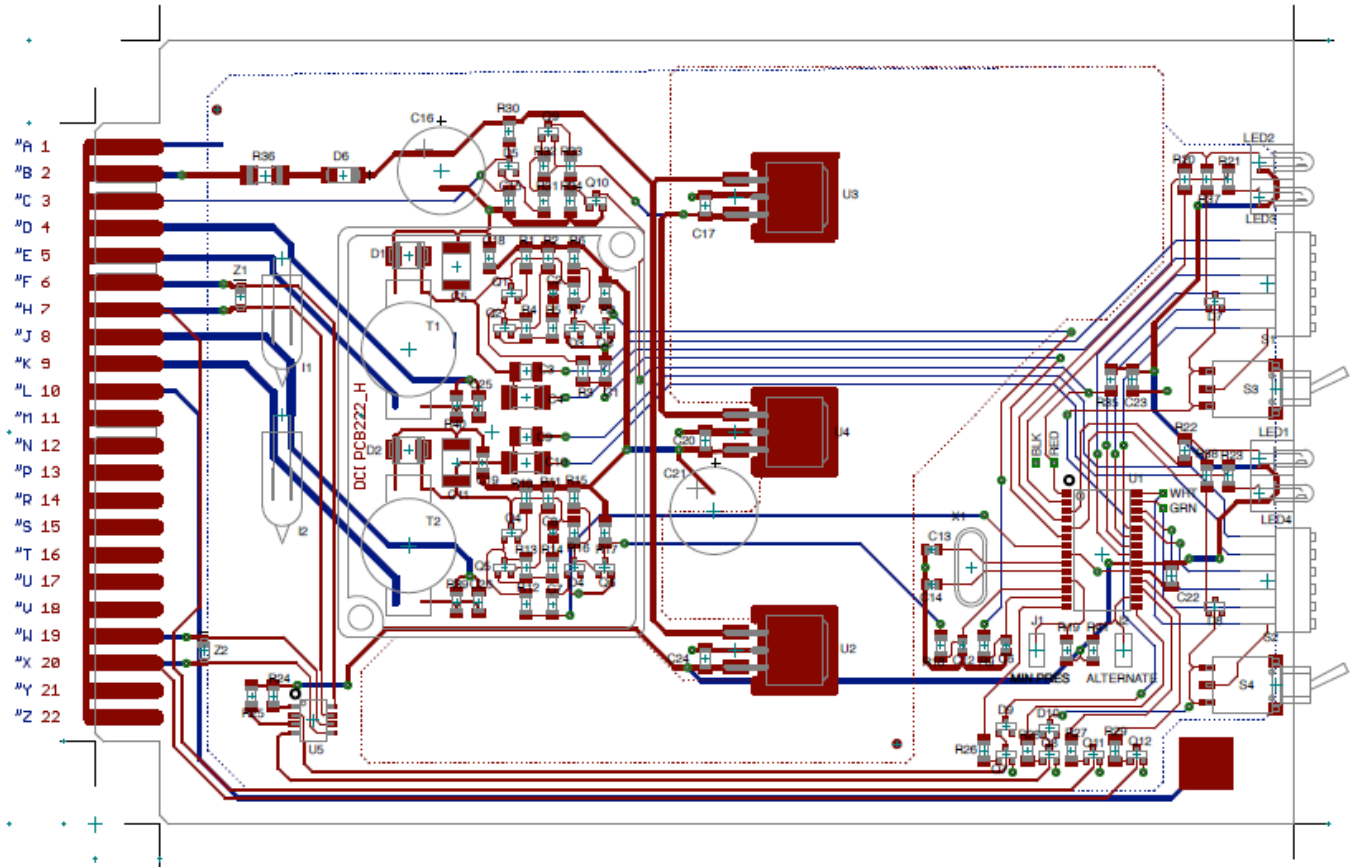

13. Specifications

Power Supply:

24 VDC $\pm 20\%$, 80 ma maximum for both channels.

Loop Input:

The loop inputs incorporate lightning and transient protection devices and the loop oscillator circuitry is transformer isolated. The lightning protection will withstand the discharge of a 10 microfarad capacitor charged to 2,000V across the loop inputs or between any loop input and earth ground.

Tuning:

Each channel of the DSP-222 series will automatically tune to any loop and lead-in combination within the tuning range upon application of power or when a valid reset signal is received. A channel can be reset by adjusting mode, sensitivity, or frequency.

Tuning Range:

50 to 750 μ H with a “Q” greater than 5.

Lead-in Length:

The unit will operate with lead-in (feeder) lengths up to 2,000 feet with Caltrans types A, B, or Q loops in all configurations as defined by California Standard Plan ES-5A & B.

Environmental Tracking:

The DSP-222 automatically and continuously compensates for environmental changes and effects throughout the entire tuning range and operating temperature range.

Fault Monitoring:

Internal monitoring of the loop system is accomplished with the microcontroller. The system is able to detect shorted or open loop systems, as well as a sudden change of inductance exceeding 25 % of the nominal value. If a fault is detected on a channel, the Fail LED will flash in a sequence related to the type of fault. The channel output will remain in the detect (call) state. If the fault condition is removed, the detect LED and the output will return to normal operation.

High-Intensity LED Indicators:

Each channel has a high-intensity red LED indicator to indicate the presence, or “call” and a high-intensity green LED indicator to indicate a failure in the roadway loop system.

Front Panel Controls:

Front panel mounted DIP switches allow the user to select sensitivity, pulse/presence and frequency on each channel.

Operational Modes:

Pulse - 125 ms \pm 25 ms momentary output

Presence Time - Meets or exceeds the State of California (Caltrans) Specifications. (Minimum presence = 10 minutes for a change of inductance of 0.06% and minimum presence = 3 minutes for a change of inductance of 0.02%)

Note: When operating in the pulse mode, a vehicle remaining over a loop will inhibit further pulse outputs from being issued for a period of 2 seconds after which time vehicles passing over the loop will again be detected.

Sensitivity:

One of seven settings may be selected to optimize detection on varying loop and lead-in configurations. Sensitivity is defined as the minimum percentage change in $\Delta L/L$ of the total inductance (loop plus lead-in). Selecting level 0 will switch the channel off. In this condition, the loop oscillator is de-energized, and the output will remain in the no call state.

Sensitivity	$\Delta L\%$	Response Time (ms)
0	Off	Off
1	.64	.5
2	.32	1
3	.16	2
4	.08	4
5	,04	8
6	.02	16
7	.01	32

Frequency:

One of four settings may be selected to eliminate crosstalk.

Reset Input:

The DSP-222 may be reset by applying a ground true logic level to the reset input pin C for a period exceeding 15 microseconds.

Electrical Interconnection:

Edge Connector mates with connector types. Cinch 50-44A-30

Pins Function

A Power and logic common

B Input power (+24 volts DC)

C /Reset

D Loop 1

E Loop 1

F Output 1 (collector)

H Output 1 (emitter)

J Loop 2

K Loop 2

L Chassis ground

M N/C

N N/C

Output Ratings:

Optically Isolated Output Versions: the output transistor is rated for a maximum collector voltage of 30 VDC. Maximum collector current is 50 mA.

Mechanical:

Dimensions 1.12 W x 4.5H x 7.0 (Excluding handle)

Environmental:

Temperature Range:

Storage: -55C to +85C

Operating: -37°C to +74°C

Humidity: 0 to 95% relative