

DSP-22-1

Low Power, Single Channel Vehicle Detector with Support for the Free-exit Probe

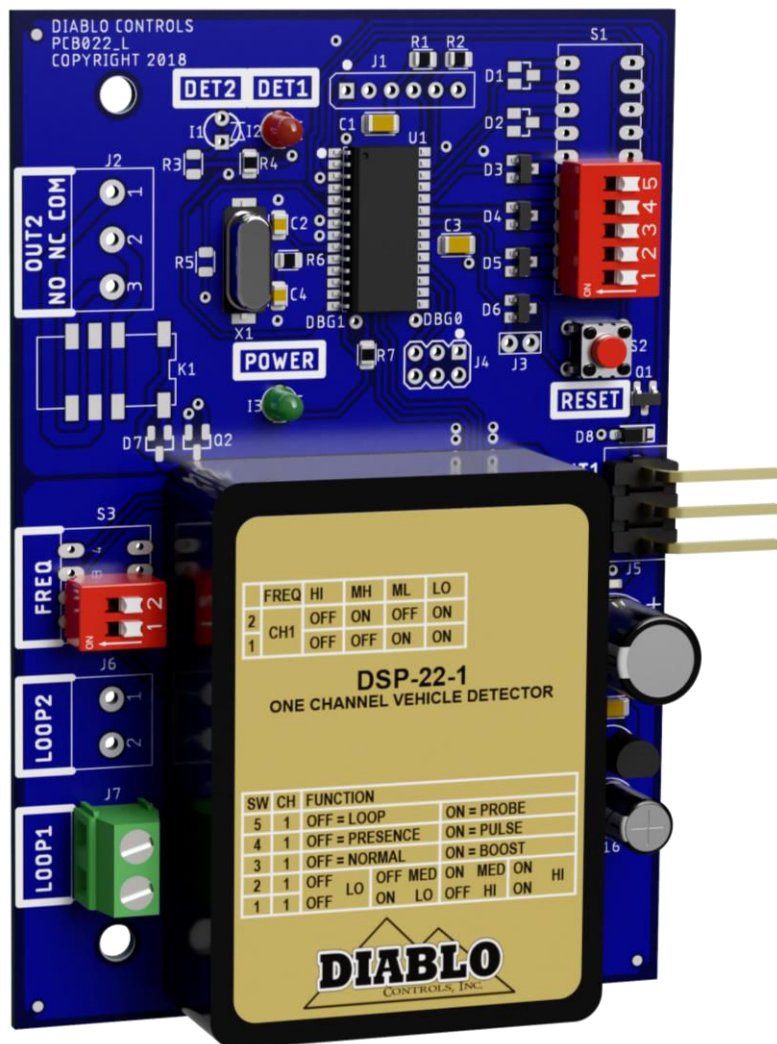

Contents

Figures	3
1. Introduction	4
Functional Data.....	5
Electrical Data.....	5
Environmental Data.....	5
Mechanical Data.....	6
2. Features and Functions.....	7
Detector Reset.....	7
Channel 1 – Sensitivity (DIP Switches 1 and 2).....	7
Channel 1 – Normal Sensitivity / Sensitivity Boost (DIP Switch 3)	7
Channel 1 – Frequency (S3 DIP Switches 1 and 2).....	8
Channel 1 – Presence / Pulse (DIP Switch 4).....	8
Channel 1 – Loop / Probe (DIP Switch 5).....	9
Indicators.....	9
3. Installation	12
General Rules and Best Practices for Inductive Loops	12
Detector Installation.....	13
Loop Installation	14
Free-exit probe Installation	17
4. Troubleshooting	19
No Power LED	19
Detect LED Flashes On Once Every Two Seconds.....	19
Detect LED Flashes On Twice Every Two Seconds.....	19
Detect LED Flashes at the Same Time as the Power LED every Two Seconds.....	20
Power LED Intermittently Comes On (Not Once Every 2 Seconds).....	20
Detect LED Intermittently Comes On / Stays On Without a Vehicle Present.....	20
Detect LED Will Not Come On With a Vehicle Present.....	21

Figures

Figure 1: Product Views.....	4
Figure 2: Physical Dimensions	6
Figure 3: Loop Installation	16
Figure 4: Saw Cut for Home Run Exit and Chiseled Corner for Home Run Exit.....	16
Figure 5 Typical Free-exit probe Installation	17
Figure 6 Side of Driving Surface Free-exit probe Installation.....	18

1. Introduction

The DSP-22-1 detector is intended to be a single channel detector that can work with both inductive loops as well as the new Diablo Control Free-exit probe. The detector is powered by a high-performance 8-bit microcontroller that does not skimp on performance. The DSP-22-1 detector has a small footprint and was designed to directly plug into many DoorKing operators.

The detector uses a 3-pin Molex connector for its power connections and the Channel 1 solid state output.

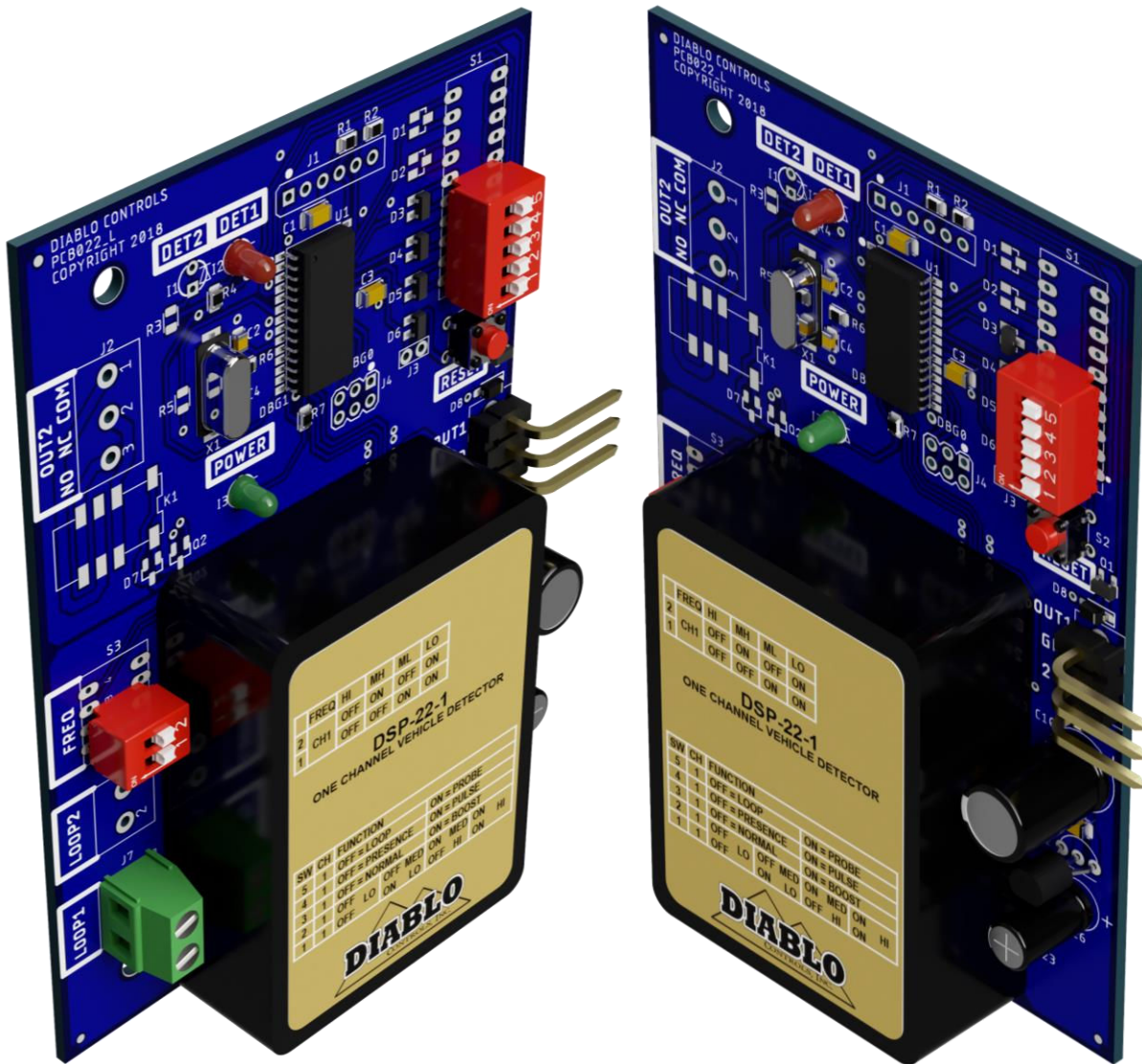

Figure 1: Product Views

Functional Data

Sensitivity: Four sensitivities for are user selectable.

S1 DIP Switch		Sensitivity
1	2	
OFF	OFF	.32% Δ L/L Low
OFF	ON	.16% Δ L/L Medium Low
ON	OFF	.08% Δ L/L Medium High
ON	ON	.04% Δ L/L High

Frequency Settings: There are four frequency settings available. The actual loop frequency is dependent on loop circuit inductance.

S3 DIP Switch		Frequency
1	2	
OFF	OFF	High
ON	OFF	Medium High
OFF	ON	Medium Low
ON	ON	Low

Pulse Output: 250ms \pm 15ms.

Response Time: 152 ms typical. 280 ms worst case.

Vehicle Hold Time: The detector will use an extended presence mode of operation. This mode allows very weak detections to be held for about 15 minutes. Strong detections can be held for very long periods of time (days or even weeks) as long as power is not interrupted.

Electrical Data

Loop Inductance: 20 microhenries to 1500 microhenries (including lead-in inductance). Not all frequency settings are available at inductances below 30 microhenries.

Operating Voltage: 14 volts to 27 volts DC

Solid State Output Rating: Maximum Output Current: 250 milliamps
Maximum Pull-Up Voltage: 30 volts
Maximum Voltage Drop Across Active Output: 0.3 volts

Current Draw: No Detect 0.69 milliamps typical @ 20VDC.
In Detect 26.43 milliamps typical @ 20VDC.

Environmental Data

Operating Temperature: -35°F to 165°F (-37°C to 74°C)

Storage Temperature: -40°F to 176°F (-40°C to 80°C)

Humidity: Up to 95% relative humidity non-condensing

Mechanical Data

Mounting Position:	Any
Housing Material:	Lexan
Detector Size:	4.300 inches (High) x 2.950 inches (Wide) x .820 inches (Deep) 109.22 mm (High) x 74.93 mm (Wide) x 20.83 mm (Deep)

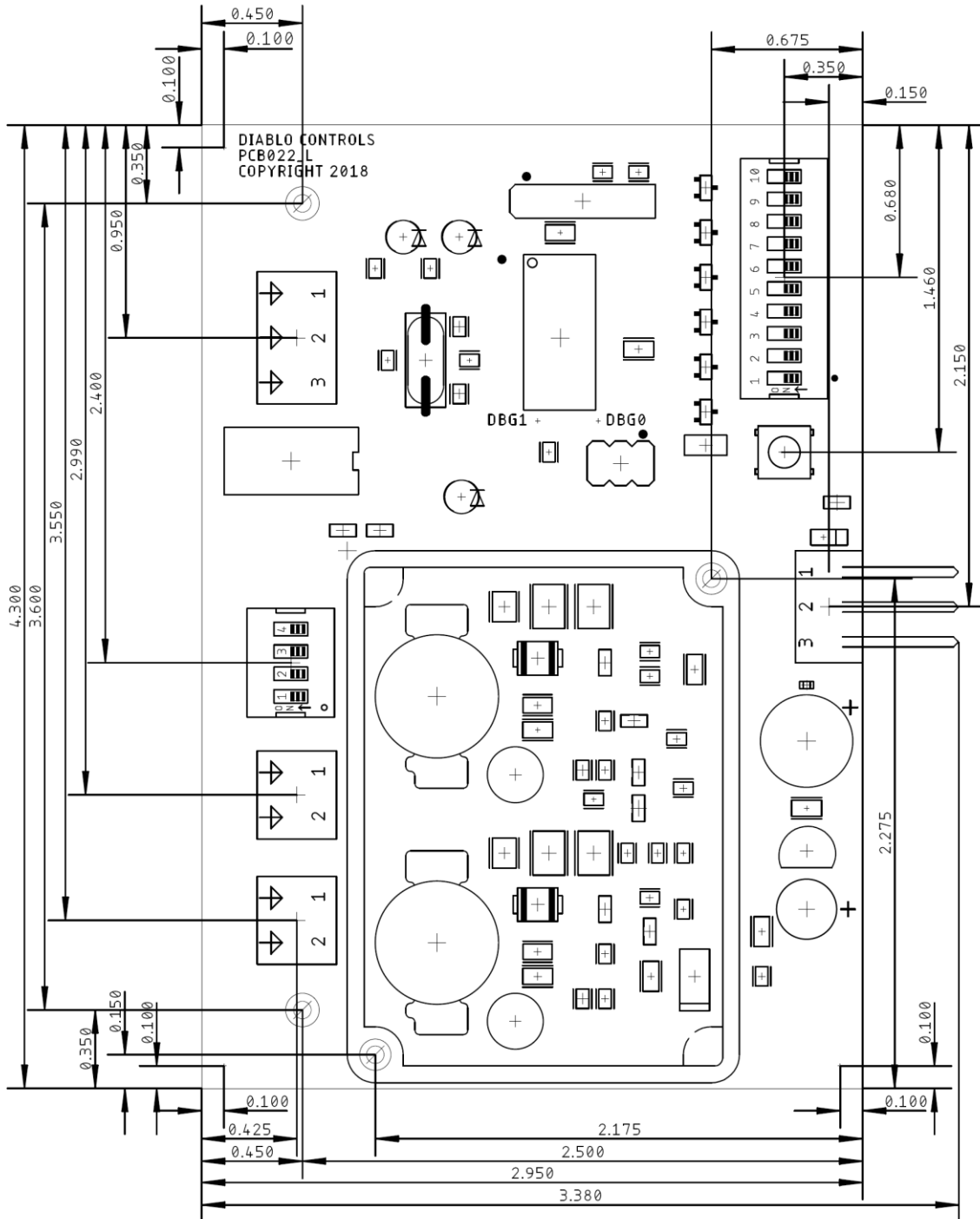

Figure 2: Physical Dimensions

2. Features and Functions

Detector Reset

When any of the DIP switches are changed, the reset button is pressed, or power is cycled to the detector, the detector will perform a reset. The reset event will last for two seconds while the detector initiates any changes and waits for all systems to stabilize.

Both LEDs will turn off for 500 milliseconds at the start of the reset event. After that, the Detect 1 LED will flash according to the fail-safe or fail-secure mode of operation. A flash rate that is the same as the power LED indicates the output is operating as fail-safe. A much faster flash rate indicates that the output is operating in the fail-secure mode.

NOTE: If a vehicle is over a loop during the reset period it will not be detected.

Channel 1 – Sensitivity (DIP Switches 1 and 2)

Channel 1 has four possible sensitivity levels. In most situations the sensitivity setting medium high (DIP switch 1 OFF and DIP switch 2 ON) will work effectively. For those situations where this setting is not sensitive enough, raise the sensitivity. For those situations where the detector is overly sensitive, lower the sensitivity one level at a time until the desired performance is obtained. Remember that semi-trucks look much smaller than a car. So, do not set or test the sensitivity using a passenger vehicle if semi-truck traffic will be seen over the loop. The factory default is low (DIP switch 1 OFF and DIP switch 2 OFF).

Like most inductive loop vehicle detectors, the DSP-22-1 directly measures the change in frequency of the loop and from there, calculates the change in inductance when a vehicle interacts with it. The change in inductance is measured as $\% \Delta L/L$ (reads as “percent delta L over L”).

For the four sensitivities, the detection thresholds are:

DIP Switch		Channel 1 Sensitivity
1	2	
OFF	OFF	.32% $\Delta L/L$ Low
OFF	ON	.16% $\Delta L/L$ Medium Low
ON	OFF	.08% $\Delta L/L$ Medium High
ON	ON	.04% $\Delta L/L$ High

Channel 1 – Normal Sensitivity / Sensitivity Boost (DIP Switch 3)

Each channel of the detector has a user selectable feature that increases the sensitivity of the detector after initial detection. This feature is most often used to allow a detector to have a lower starting sensitivity and then increase it after a vehicle has been detected. This is useful in situations where high-bed tractor-trailer vehicles will be passing over the loop. With this feature the detector may be able to detect the high-bed portion of the vehicle

without having to be overly sensitive and susceptible to false detections. NOTE: If detection of high-bed tractor-trailers is required, correctly sized loops must be used.

DIP Switch 3	Function
OFF	Channel 1 Normal Sensitivity
ON	Channel 1 Sensitivity Boost

Channel 1 – Frequency (S3 DIP Switches 1 and 2)

When loops are installed sufficiently far apart, any two loops will not interfere with each other. However, if two loops are fairly close together, say two to four feet apart, the inductive fields may couple together and may interact causing intermittent false detections. The main variables for inductive coupling are loop size, distance between loops, and the loop frequency. Loops that are connected to the same DSP-22-2 detector can not interfere with each other, as the detector will only turn on one of the loops at any point in time (this is referred to as scanning). To aid in mitigating inductive coupling, each DSP-22-2 unit comes with two frequency switches for each channel. They are binary coded allowing up to four different operating frequencies.

If there are suspicions that loops are interacting, change one of the detector’s frequency settings for the suspect channel so that their inherent frequencies are sufficiently different as to no longer interact. If the loops are the same size and number of turns, setting one channel to high and the other channel to low will provide the maximum frequency separation.

DIP Switch		Frequency
1	2	
OFF	OFF	Channel 1 High
OFF	ON	Channel 1 Medium High
ON	OFF	Channel 1 Medium Low
ON	ON	Channel 1 Low

Channel 1 – Presence / Pulse (DIP Switch 4)

The operating mode for channel 1 is selected with DIP switch 4 (Presence or Pulse) and affected by the setting of DIP switch 5 (Loop or Probe). Presence detection for channel 1 is only available in the inductive loop mode of operation (DIP switch 5 OFF). If channel 1 is in the probe mode of operation only pulse on entry operation is available regardless of the setting of DIP switch 4.

In the Presence mode of operation, once activated, the output will remain activated for as long as a vehicle is detected over the loop. After four minutes of continuous detection, the detector will begin a proprietary algorithm that is designed to be able to reliably detect the vehicle for long periods of time (days or even weeks) while still being able to drop the detection once the vehicle exits the loop.

When the probe mode of operation is selected (DIP switch 5 ON), pulse on entry is the only detection mode of operation for Channel 1. If DIP switch 5 is OFF and DIP switch 4 is ON, Channel 1 is in the pulse mode.

- Reset** At the start of a reset event (a DIP switch change, sensitivity change, or power cycle) the LED will turn off for 500 milliseconds, on for 500 milliseconds, off for 500 milliseconds, and then display its normal state.
- High Speed Operation** The LED is always on when the detector is in its high-speed mode of operation.
- Low Power Operation** The LED will blink on once every 2 seconds when the detector is in its low power mode of operation.

Detect 1 LED – The red Detect 1 LED is used to display the status of Channel 1. There are several different statuses that can be displayed on this LED:

- Off** No vehicle present in the detection area and the loop is functioning normally and there has not been a prior fault in the last week.
- Reset in Fail-safe** At the start of a reset event (a DIP switch change, sensitivity change, or power cycle) the LED will turn off for 500 milliseconds, on for 500 milliseconds, off for 500 milliseconds, on for 500 milliseconds, and then finally display its normal state.
- Reset in Fail-secure** At the start of a reset event (a DIP switch change, sensitivity change, or power cycle) the LED will turn off for 500 milliseconds, on for 500 milliseconds, blink repeatedly with 50 milliseconds on followed by 50 milliseconds off for one second, and then display its normal state.
- Detect** The LED is on constantly when a vehicle is detected.
- Open Loop** When the detector senses that the loop is open, or the inductance is too high, the LED will flash once every two seconds repeatedly, for the duration of the fault. If the fault is corrected the LED will display the appropriate Prior Fault indication.
- Shorted Loop** When the detector senses that a loop is shorted, or the inductance is too low, the LED will flash twice every two seconds repeatedly, for the duration of the fault. If the fault is corrected the LED will display the appropriate Prior Fault indication.
- Large Change Fault** When the detector senses that a loop is experiencing a large inductance change (greater than 25%), the LED will flash three times every two seconds repeatedly, for the duration of the fault. If the fault is corrected the LED will display the appropriate Prior Fault indication.
- Prior Fault** The detector is equipped with the ability to remember prior faults that have occurred since the last power interruption or reset (changing a DIP switch or the sensitivity). The detector will hold this status for one week

and then automatically clear the status. In the high-speed mode of operation (green LED is ON) and the channel is not in detect, the LED will flash on one, two, or three times depending upon the prior failure type. When the detector is in the low power mode (Green LED flashes on once every 2 seconds), the channel Detect LED will flash on at the same time.

3. Installation

General Rules and Best Practices for Inductive Loops

Before beginning the installation, it is important to make that the loop you are about to use is appropriate for this installation. Here are some general rules and best practices that will help you ensure that the loop you use will have the desired performance and a long life.

1. The preferred insulation material for loop wire is cross-linked polyethylene (XHHN or XHHW are types of this wire). Wire with PVC insulation should never be used. This includes THHN. The cross-linked polyethylene is a much more durable insulation and, more importantly, has a much lower moisture absorption rate. Moisture absorption can affect loop stability.
2. Wire gauge of the loop wire has little to no impact on the sensitivity of the loop. A larger wire gauge may help extend the life of the loop, especially in asphalt installations where heavy truck traffic is expected.
3. Wire nuts should never be used in loop connections. At a minimum wire to wire connections should be crimped or use a screw terminal. Ideally, solder the connections.
4. Loop saw cuts should be mitered to reduce the loop wire bend angle to not exceed 45 degrees at any location.
5. Use backer rod to hold the loop wire at the bottom of the saw cut before sealing the loop. The backer rod should be cut into 1-inch pieces and one placed every foot or so, as needed.
6. If a loop installation will cross an expansion joint in the roadway surface some method of leaving some slack wire at the joint should be implemented. This can be done by core drilling a 1" or larger hole where the saw cut crosses the expansion joint and leaving a loop of wire in the hole each time you go through it when installing the loop wire. The other option is to dip the saw at the expansion joint to make the saw slot at least two inches deeper at the joint. Then when installing the loop wire, ensure that the wire lays all the way at the bottom of the saw slot at the expansion joint.
7. Useable detection height of a loop is 2/3rds of the shortest leg of the loop. Therefore, if you need to detect semi-truck trailers, no side of the loop can be shorter than 6'.
8. The approximate inductance of the loops can be calculated using the formula:

$$L = (P / 4) \times (N + N^2)$$

Where: L = Loop Inductance in microhenries (μ H)

P = Perimeter of the loop in feet

N = Number of turns (wraps) in the loop

For example, a 6' by 14' loop with 2 turns would be:

$$L = ((6 + 14 + 6 + 14) / 4) \times (2 + 2^2)$$

$$L = (40 / 4) \times (2 + 4)$$

$$L = 10 \times 6$$

Loop Inductance is approximately 60 μ H.

9. The approximate inductance of the lead-in cable can be calculated using a value of .22 μH per foot for lead-in cable.

$100' \times .22 \mu\text{H} = 22 \mu\text{H}$ of inductance in 100' of lead-in cable.

10. The ratio of loop inductance to lead-in inductance should be 2 to 1 for a well-designed installation. Since the vehicle to be detected can only influence the loop inductance, letting the lead-in inductance get close to the loop inductance will effectively lower the sensitivity of the loop. This is usually only an issue when the loop is 50' or more away from the detector. If you do have a long lead-in, additional turns should be added to the loop until the 2 to 1 ratio is satisfied.
11. The ideal loop inductance is 50 to 500 μH . Although the detector will tune to loops in the range of 20 to 1000 μH , the 20 to 50 range should be avoided to provide a more stable loop and loss of sensitivity due to lead-in inductance. It is always better to have too much inductance than too little.
12. Lead-in wires must be twisted. Ideally, 3 to 6 twists per foot should be maintained. It is also important that the twists are tight. An air gap between the two wires should not exist as this can cause loop stability issues. The lead-in wires should be kept twisted until right before connection to the detector.
13. A figure 8 loop can be used in locations where electrical interference is expected or seen. This is a standard loop with an extra saw cut down the middle of the loop. This extra saw cut should point toward the source of the interference as much as practical. If the source is overhead or below ground (power lines) the saw cut should be parallel to the short side of the loop. The loop wire is placed in the saw cuts using a figure 8 motion. A figure 8 loop will have more inductance than a similar sized conventional loop.
14. If multiple loops are to be connected to the same detector there are several things to be aware of:
 - a. Always connect multiple loops in series. This increases the inductance and insures that a loop failure will cause a loop fault at the detector.
 - b. The loops connected together **must** be the same size and the same number of turns. Failure to do this will lead to the loops having different sensitivities that cannot be compensated for. This difference in sensitivity can very large.
 - c. Connecting two loops together will reduce the sensitivity of each loop by half.
 - d. If the two loops are within 6' of each other, the phasing of the loops should be considered. If the loops are on the same side of a gate and are being used to increase the size of the detection zone, the two edges closest to each other should have opposite phasing (North to South). This will increase the sensitivity in the area between the two loops. If the loops are on opposite sides of a gate, the loops should have the same phasing (North to North). This will decrease the sensitivity in the area between the two loops. Especially at the middle point between the two loops, it may be impossible to detect any object in this area. So, this phenomenon can be very useful in sliding gate and lift gate installations.

Detector Installation

Location: The detector should be plugged in to the appropriate connector on the DoorKing operator.

Mounting: The detector will function when mounted in any orientation. Using the two holes in the detector, secure the detector in place.

Wiring: Attach the loops to the appropriate loop screw terminals. Wire nuts should never be used at any point in the loop circuit itself. All loop connections should be crimped or use screw terminals at a minimum and soldered for best long-term reliability. Special attention should be paid to ensure that the loop wires remain tightly twisted together. An air gap between the two wires for a loop may cause the detector to lock up if the wires are disturbed.

If connecting two loops to one channel of a detector, there are certain rules you should follow:

1. Always connect multiple loops in series, not parallel. A failure of one loop may not be identified if the loops are connected in parallel.
2. The loops should be the same size, shape, and have the same number of turns. If any of these items are different, the loops will have different sensitivities that cannot be adjusted for. The difference in sensitivity could be very significant.
3. Do not use a wire nut to connect the wire from each loop together. Wire nuts have a spring in them and will expand and contract with temperature. Even the slightest change in resistance can cause detector lock-ups.

Loop Installation

The reliability and overall performance of the detector are greatly dependent on the loop itself. Several factors go into a good loop installation: type of wire used, loop configuration, and installation practices.

Type of Wire Used: The wire used for wiring the loop should have a jacket of cross-linked polyethylene or similar material that has very low moisture absorption properties. This would be a wire with an XLP jacket such as XHHW. THHN or similar wire types should never be used for loop wire.

The gauge of the wire to use depends on two factors: Distance in cable feet from the loop to the detector and stresses the wire may see. The gauge of the wire can be 20 AWG as long as the detector is within 50 feet of the loop in cable distance. For 50 to 100 feet, use at least 18 AWG wire. At greater than 100 feet, use a 16 AWG wire at a minimum. If the loop is installed in asphalt and there will be heavy vehicles or stopping and starting vehicles in the loop area, a 14 AWG or 12 AWG should be used to provide additional strength to the loop. This helps increase the life of the loop in areas where the asphalt may slowly move and/or deform due to wear and/or temperature.

Loop Configuration: The size and shape of the loop will determine what type of vehicles it can reliably detect. There are many variables that come into play including loop dimensions, percent of coverage, length of lead-in wire, number of turns in the loop area, and detection height to name just a few of them. One common rule is that the useable field height of a loop is $\frac{2}{3}$ of the shortest leg of the loop. So, if you plan on using a 2.5' x 6' loop, the expected useable detection height would be 20" (The shortest leg is 2.5' or 30", $30" \times 2 = 60"$, $60" / 3 = 20"$). If the installation requires the detection of motorcycles as well as vehicles, the loop should go to within one foot of the curb or roadway edge, whichever is present. If only motor vehicle detection is required, within three feet of the curb or roadway edge is all that is required.

The number of turns to use in a loop is dependent on the size of the loop and length of the lead-in. Rather than dive into all of the calculations to arrive at a value, we will just give you a table of safe values based on the number

of square feet in the loop (length times width in feet). If you are unsure about your particular installation, call tech support for guidance.

Loop Size in Square Feet	Recommended Turns for <100' of Lead-in	Recommended Turns for 100' to 199' of Lead-in	Recommended Turns for 200' to 299' of Lead-in
5 to 6 square feet	7	8	10
7 to 9 square feet	6	7	9
10 to 15 square feet	5	6	8
16 to 23 square feet	4	5	6
24 to 54 square feet	3	4	5
55 to 150 square feet	2	3	3

Installation Practices: Permanent loops should be installed into the road surface by cutting slots into the road surface using a saw with an appropriate cutting disk for the road surface.

The slot cut should be wide enough that the wire being used will easily fit into the slot. This is needed so that the loop sealant used can fully encapsulate the wire. When the wire fits tightly in the slot, the sealant may not be able to get below the wire, leaving air pockets in the saw slot. If water finds its way in to these air pockets, over time, freeze thaw cycles can slowly jack the loop out of the saw slot causing loop failure.

The saw slot should be deep enough that the loop wire will have a minimum of ½” of sealant over the top wire in the slot. More is better. Going too deep with the saw cut is also a concern. Deep cuts in a road surface may impact the structural strength of the roadway, especially if any reinforcement material is cut. Using a smaller gauge of wire will allow for shallower saw cuts.

The corners of the loop should be crosscut at a 45° to help prevent damage to the wire insulation during installation and temperature cycling. The angled cuts should be at least 9” back from where the corner would be. The saw cuts should not go any further than necessary to ensure that the saw slots are at full depth where they meet.

Special consideration should be given to where the home run saw cut meets the loop saw cuts. Here either an additional saw cut should be made as shown in Detail A or the inside of the sharp corner should be removed with a chisel as shown in Detail B.

Once the saw slot has been cut, the slot should be cleaned of all loose material. High-pressure air should be directed in to the saw slot to remove all debris. This will also help remove dust from the saw cutting operation from the sides of the saw slot. This will allow better adhesion of the loop sealant to the saw slot.

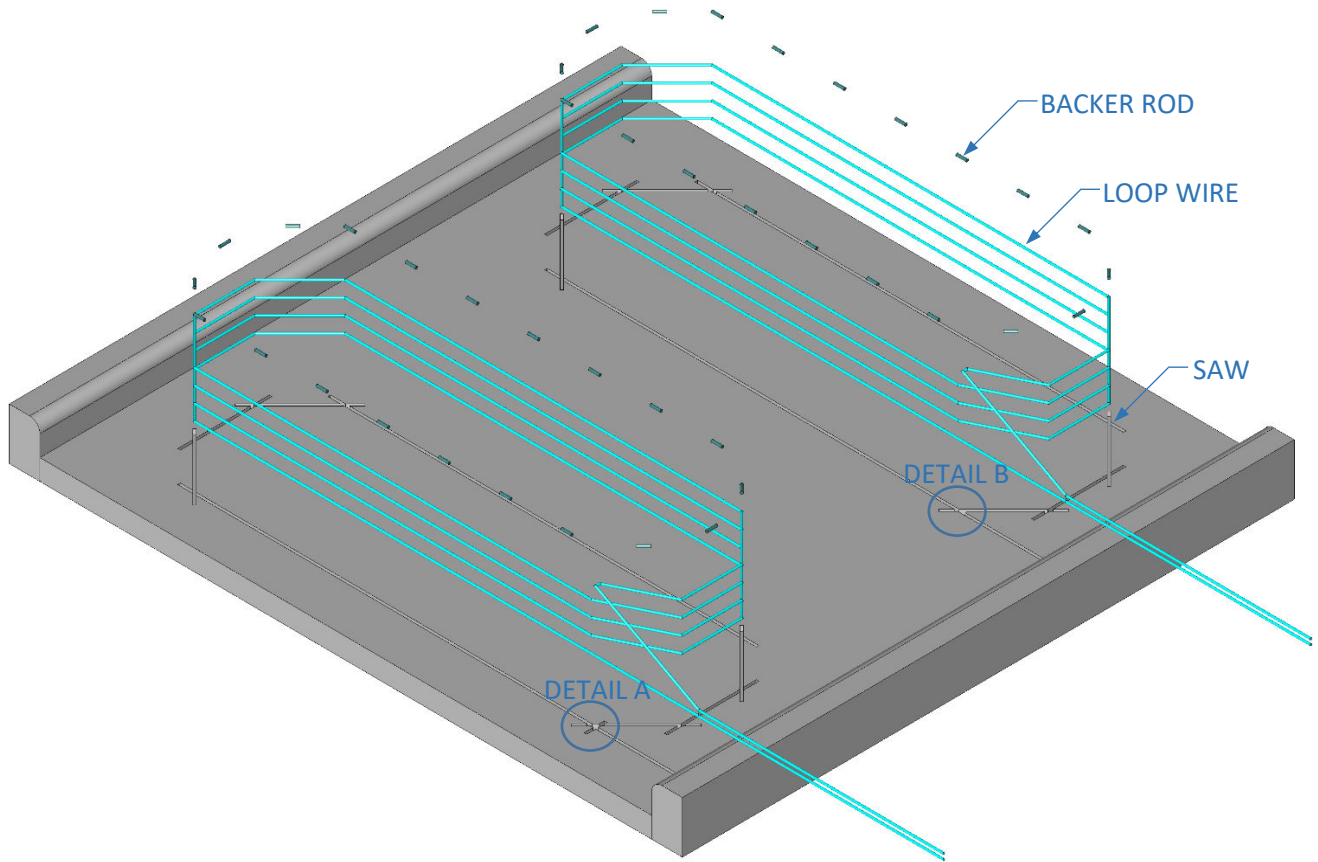

Figure 3: Loop Installation

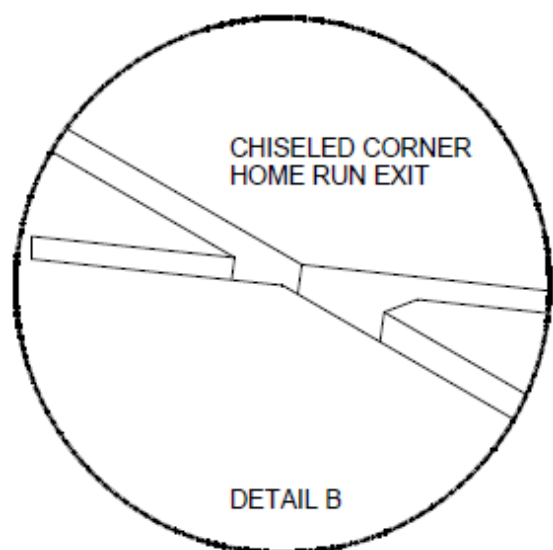
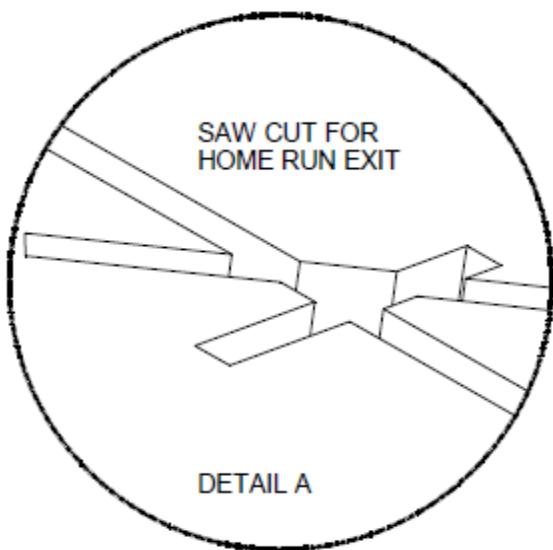

Figure 4: Saw Cut for Home Run Exit and Chiseled Corner for Home Run Exit

The loop wire should be installed as a continuous piece of wire from the detector to the loop, all of the turns in the loop, and back to the detector. Remember to make allowance for shrinkage in the wire length when the portion of the wire not in the roadway surface is twisted. The twisting is important for dealing with electrical noise. A splice of the loop wire should never be made in the roadway. If the loop wire needs to be spliced to another cable to get to the detector, the splice should be done in a junction box and the connections should be soldered and weatherproofed. Wire nuts should never be used at any point in the loop circuit.

In order to keep the loop wire at the bottom of the saw slot, 1" to 2" pieces of backer rod should be placed in the saw slot every 1 to 2 feet. The backer rod should be sized such that it fits snugly in the saw slot. Use a blunt object (not a screwdriver) to press the backer rod pieces down into the saw slot as far as they will go. Keeping the loop wire at the bottom of the saw slot allows the loop sealant to provide the maximum amount of protection possible from foreign object penetration. Never use a continuous piece of backer rod over the loop, as this would prevent the loop sealant from encapsulating the loop wire.

The loop sealant used should be appropriate for the roadway surface that was cut. Generally, epoxy or polyester based sealants are used for concrete surfaces and polyester or polyurethane based sealants are used for asphalt surfaces. However, these are not hard guidelines and specific circumstances will determine which type of sealant should be used.

Once the loop wire leaves the saw slot it should be twisted at least three times per foot. More is better. The twists should be kept tight to be most effective in reducing the effects of electrical interference.

Free-exit probe Installation

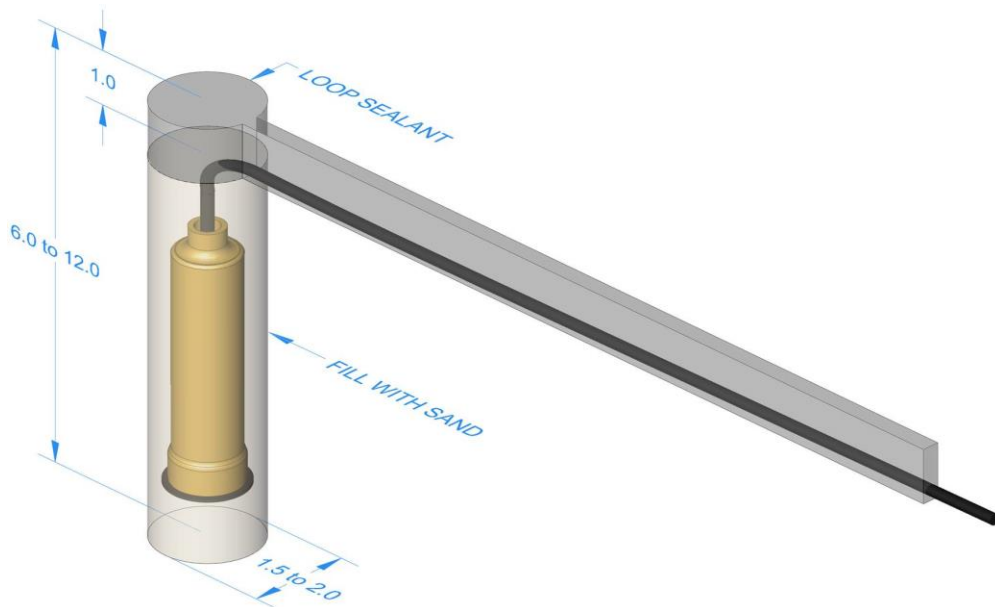

Figure 5 Typical Free-exit probe Installation

Side Detection Zone Placement

NOTE: When the roadway is greater than 11 feet wide requiring a greater detection zone you have the option to add a second Free-exit probe to the opposing side of the roadway. The probes must be wired in series.

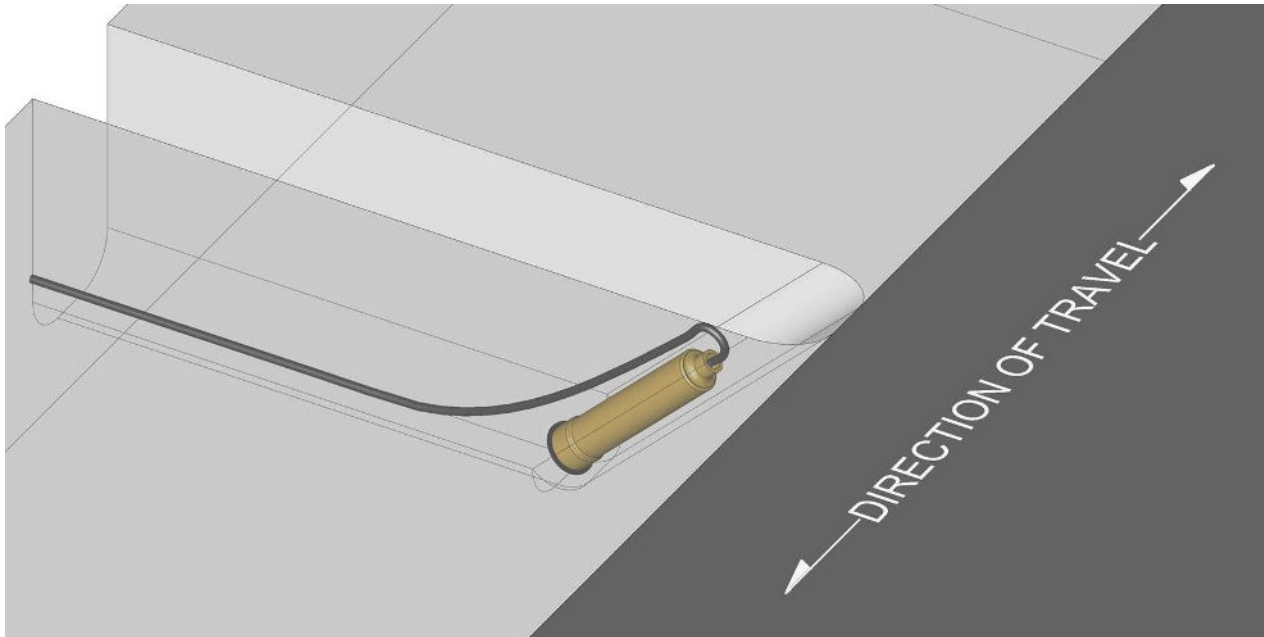

Figure 6 Side of Driving Surface Free-exit probe Installation

4. Troubleshooting

No Power LED

The first step is to ensure that the correct model of the detector is being used for the installation. Ensure that the wiring is correct, and the correct voltage is being used.

Use a meter to measure the voltage applied to the detector. The voltage must be between 14 volts and 27 volts DC.

If the correct voltage is applied and the power LED is not on, replace the detector.

Detect LED Flashes On Once Every Two Seconds

This flash count indicates that the detector channel has an open loop, a high resistance in the loop circuit, or excessive inductance.

The first step is to confirm that the channel has a loop connected to it and the loop is connected to the correct loop terminals (see the wiring configuration for the pin out).

If a loop is connected to the correct terminals of the detector, disconnect the loop and using an ohmmeter, check the resistance of the loop circuit. If the resistance is above 5 ohms there is a bad connection, or the wire has been damaged. The resistance will typically be 1.5 ohms or less.

If the resistance is below 5 ohms, the loop inductance should be checked. This is done using an inductance meter. The inductance of the loop should be less than 1500 microhenries. It is very unusual to have a loop with an inductance value this high, but it is possible with very large loops and many turns. If the loop inductance value is above 1500 microhenries, the loop will have to be replaced with a loop with less inductance. Contact technical support for help with very large loops.

If you do not have a meter capable of measuring resistance and/or inductance but do have another operating detector in the same box, you can skip to this step. Swap the loops between a working detector and a failing detector. If the problem follows the loop the loop is the problem. If it stays in the same detector, replace the detector.

Detect LED Flashes On Twice Every Two Seconds

This flash rate indicates that the channel has a shorted loop, a low resistance across the loop circuit, or insufficient inductance.

The first step is to confirm that the loop is connected to the correct screw terminals. If the wiring is correct, the next step is to confirm that the detector is working correctly. Disconnect the loop wires for the detector. The LED should begin flashing just once every two seconds. If it does not change its flash count, change the detector.

If a loop is connected to the correct screw terminals of the detector, disconnect the loop and using an ohmmeter, check the resistance of the loop circuit. If the resistance is below 0.2 ohms there is a short in the loop circuit. The resistance will typically be 0.5 ohms to 1.5 ohms.

If the resistance is above 0.2 ohms, the loop inductance should be checked. This is done using an inductance meter. The inductance of the loop should be more than 20 microhenries. If the loop inductance is less than 20 microhenries, the loop was probably not wound correctly and only has one turn in it. In this case the loop must be replaced. Other possibilities include a foreign object embedded in the saw slot and shorting some or all of the wires, or failed wire insulation due to the wire being exposed or the wrong type of wire being used. Very small loops may also have a low inductance value if sufficient turns were not added. Contact technical support for help with very small loops.

If you do not have a meter capable of measuring resistance and/or inductance but do have another operating detector, you can skip to this step. Swap the loops between a working detector and a failing detector. If the problem follows the loop the loop is the problem. If it stays in the same detector, replace the detector.

Detect LED Flashes at the Same Time as the Power LED every Two Seconds

This flash rate indicates that the channel has had a failure of some type but is currently working correctly.

Intermittent failures are usually open loop failures. Any splices in the loop wire should be redone. If there are any wire nuts used in the loop circuit, remove them, and replace with a crimp connection or preferably, a soldered connection. The open loop fault could also be a fatigued point in the loop wire. This can occur at locations where the loop wires cross an expansion joint in the road surface. Any place where the loop wires must move, even if only a very tiny amount, can cause wire fatigue. The actual failure point may be very difficult to find. Often the loop must just be replaced if the issue persists but cannot be found.

It is possible for the intermittent failure to be a shorted loop fault. One possible source of this type of fault is a foreign object being embedded in the loop saw cut and damaging the wire. Another is that the loop wire has been damaged where it enters or exits a conduit or junction box, or that a conduit that the loop wire is in has been damaged (crushed, kinked, bent, cut, etc.).

Power LED Intermittently Comes On (Not Once Every 2 Seconds)

This type of display is an indication that the detector is experiencing electrical interference. This could be cross-talk with another loop connected to a different detector or an external source of noise. These external sources can be radio transmitters, card readers, or any electrical device that is within several feet of a loop.

Detect LED Intermittently Comes On / Stays On Without a Vehicle Present

This type of symptom is usually caused by one of three issues: physical issues with the loop, electrical interference, moving objects in proximity to the loop.

Physical Issues with the Loop – There are many ways in which a loop installation can go bad. The insulation of the loop wire can fail. This can be due to the loop wire being exposed in the saw lot, damage to the wire insulation

during loop installation, physical stressing of the wire due to movement (crossing of expansion joints or asphalt that has slowly moved or deformed), wires moving in the saw slot due to poor loop sealant encapsulation, foreign objects embedded in the saw slot, and poor electrical connections in the loop circuit.

The best way to check for any of these issues is to use a megohmmeter (commonly referred to as a megger). Disconnect the loop wires in question from the vehicle detector and any other electronic equipment. Connect one lead of the megger to one end of the loop wire and the other lead to earth ground. Measure the resistance. For accurate measurements the ground and the loop should be wet or at least damp (use a hose or a bucket of water if needed to get the area wet). The reading should be at least 100 megohms. If it is less than 50 megohms the insulation is compromised, and the loop circuit should be replaced. Between 50 and 100 megohms, the loop may or may not work properly and reliably.

Electrical Interference – There are several possible sources of electrical interference: loop cross-talk, power lines, electric motors, and insufficient twisting of the loop wires, just to name a few.

Other loops in the area that are connected to a different detector are prone to cross-talk (when the magnetic fields from different loops interfere with each other). Adjusting the loop frequency of one or both of the loops in the same area will usually allow you to find a setting that both loops will work reliably with.

Anything that uses electricity is a possible source for electrical interference depending on its proximity to the loop and the amount of energy being used. If you believe the loop is experiencing electrical interference, turn off the device believed to be the source of the interference and see if the problem goes away. Sometimes this is not possible and more technical means are needed to help identify the source. Call Technical Support in this case.

If the electrical interference is occurring in the wire from the loop to the detector, additional twisting should help mitigate the issue.

Moving Objects in Proximity to the Loop – Objects that can move and are metallic or somehow electrically conductive, may cause detection issues.

A common issue is movement of a slide gate or gate arm in close proximity to a loop. The best solution would be to move the detection area further away from the moving gate. We recommend that all loops should be at least 4 feet from a slide gate. Try lowering the sensitivity one level so that the desired vehicles are still detected, but not the moving gate. NOTE: Do not lower the sensitivity too much or vehicles will no longer be detected.

Another possibility is metal objects in close proximity to the loop. Utility manhole covers are objects that may move slightly when vehicle tires drive over them, especially if the vehicle turns while a tire is on the cover. Most manhole covers can be bolted in place. Contact the owner of the manhole to see what can be done to mitigate the cover movement.

Detect LED Will Not Come On With a Vehicle Present

The first thing to do is verify that the LED in question is still working. This is accomplished by a quick lamp test. Reset the detector by pressing the RESET button. All three LEDs should turn off and turn on. If a Detect LED does not illuminate, replace the detector.

If the red LED illuminates, then perhaps the sensitivity setting is too low. There are many variables in determining overall sensitivity: loop size, number of turns, loop lead-in, percent coverage, etc. In most cases, a sensitivity setting of medium high is the correct setting. However, to compensate for some unusual loop geometries, this setting may be inadequate. Adjust the sensitivity one level higher and recheck the detector for proper detection.

If the channel sensitivity is set to high and the red LED still does not come on and you have another operating detector, swap the loops between a working detector and a failing detector. If the problem follows the loop the loop is the problem. If it stays in the same detector, replace the detector.