

# SENTIR

*edge* 92.20 RT

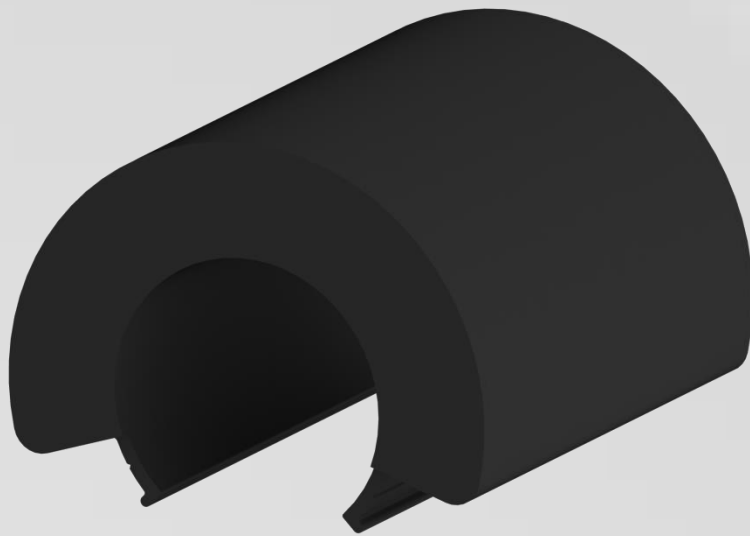

Produktinformation | Product information

**ASO** Safety  
Solutions

# Spezifikationen *Specifications*

SENTIR *edge*  
92.20 RT

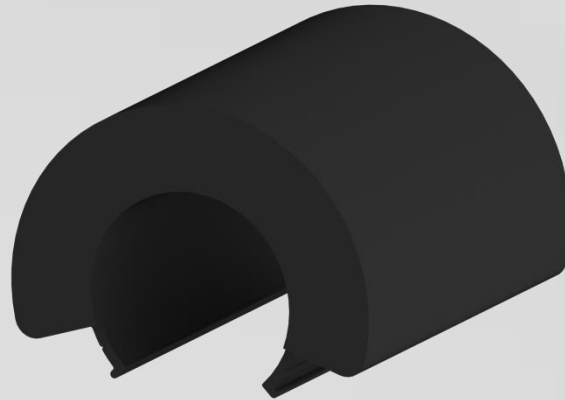

SENTIR *edge* 92.20 R T

ASO-Sicherheits-  
kontakteleisten  
*ASO-Safety contact  
edges*

Profilbreite  
*Profile width*

Profilhöhe  
*Profile height*

Material/*material*  
T: TPE

Ausführung/  
*Shape*  
R: Rund  
*Round*

# Spezifikationen *Specifications*

## SENTIR *edge* 92.20 RT

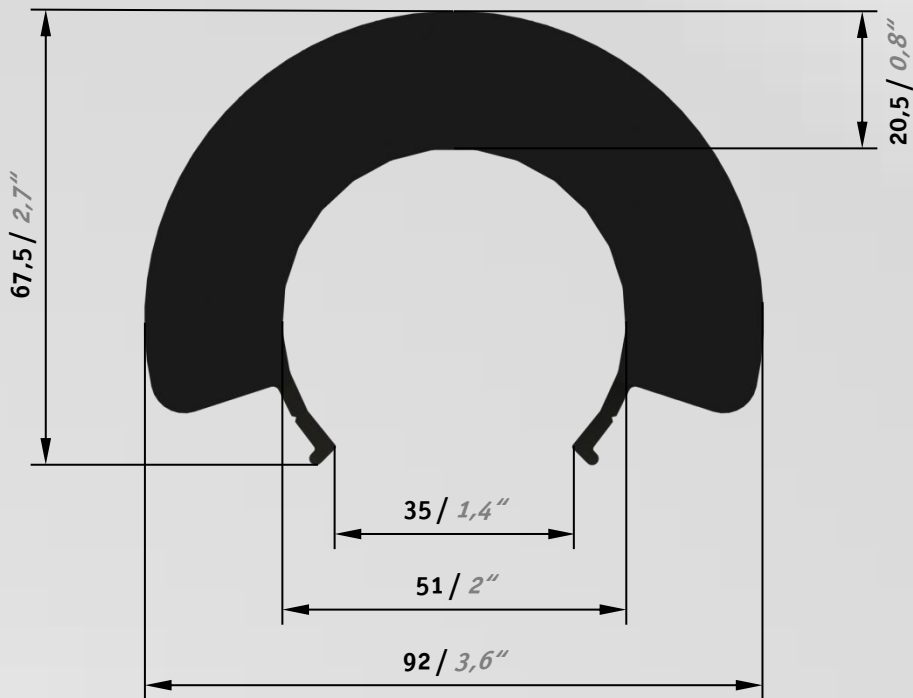

Maße in mm, Toleranzen nach DIN ISO 3302-1 Klasse E2  
*Dimension in mm, Tolerances according to DIN ISO 3302-1 class E2*

\* Verkleinerung auf Anfrage möglich  
*\* Reduction possible on request*

Max. Lieferlänge: <i>Max. delivery length:</i>	Auf Anfrage <i>On request</i>
Dimensionen: <i>Dimensions:</i>	92 mm W x 67,5 mm H <i>3,6" W x 2,7" H</i>
Zertifizierung: <i>Certificates:</i>	UL 325

# Technische Daten

## Technical data

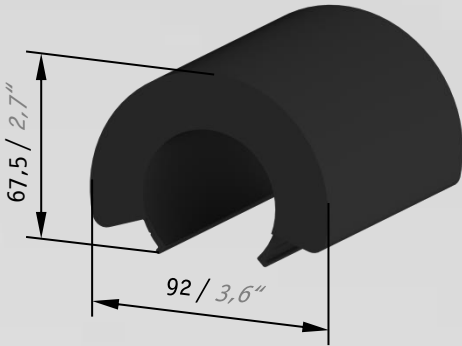

Maße in mm, Toleranzen nach DIN ISO 3302-1 Klasse E2  
Dimension in mm, Tolerances according to DIN ISO 3302-1 class E2

### Kennwerte für Prüftemperatur +20°C

Characteristics for test temperature +20°C

Betätigungskraft F Actuation Force F	39 N
---	------

Prüfung gemäß UL 325 „NORMAL OPERATION TEST“  
Test according to UL 325 „NORMAL OPERATION TEST“

Allgemeine Daten		General Data
Typ	SENTIR edge 92.20 RT	Type
Artikel-Nummer	1501-0480	Article No.
Material	TPE	Material
Materialhärte	90/68 Shore A	Material hardness
Max. Lieferlänge	Auf Anfrage / On request	Delivery length
Schutzart	IP 65	Enclosure
Schaltspiele	10.000	Switching Cycles
Schaltwinkel	2 x 90 °	Switching Angle
Betätigungswiderstand	≤ 500 Ohm	Actuation resistance
Elek. Belastbarkeit	24 V 10 mA	Electrical capacity
Betriebstemperatur	-10 °C → 55°C	Operating temperature
Max. Temperaturbereich	-25 °C → 75°C	Max. temperature range
Max. Reihenschaltung der Kontaktleiste	5 Kontaktleisten	Max. series connection of the contact edges
Inaktiver Bereich mit höheren Kräften	30 mm	Inactive end region with higher forces
Leitung (max. 25m)	LIY11Y 2x0,34 mm <sup>2</sup>	Connection cables
Material Leitung	PUR matt schwarz	Cable material

**!** Die Reaktionszeit der angeschlossenen Auswertelektronik beeinflusst die ermittelten Nachlaufwege der Kontaktleiste.  
The response time of the used controller affects the measured overtravel distances of the contact edge.

# Technische Daten

## Technical data

### Materialeigenschaften

Material properties

Allgemeine		General
Reißfestigkeit	3	Tear strenght
Reißdehnung	3	Ultimate tensile strenght
Rückprallelastizität bei 20°C	2	Rebound elasticity at 20°C
Widerstand gegen bleibende Verformung	3	Resistance against permanent deformation
Abrieb	3	Abrasion
Weiterreißwiderstand	3	Elongation @ Tear
Kälteflexibilität	2	Cold flexibility
Wärmebeständigkeit	2	Heat stability
Oxidationsbeständigkeit	1	Oxidation stability
UV-Beständigkeit	1	UV-stability
Witterungsbeständigkeit	1	Weather resist.
Flammwidrigkeit	6	Flame resistance
Ozon (50 ppm)	1	Ozone (50 ppm)

1 = sehr gut → 6 = ungenügend      1 = very good → 6 = insufficient

Chem. Beständigkeit		Chem. resistance
Wasser (dist.)	1	Water (dist.)
Säure (verd.)	1	Dilutes acid
Laugen (verd.)	1	Dilutes base
Nicht oxid. Säuren	2	Not oxidizing acids
Oxidierete Säuren	2	Oxidizing acids
ASTM-Öl Nr. 3	6	ASTM-oil No. 3
Mineralöl	2	Mineral oil
Bremsflüssigkeit	2-3	Brake fluid
Frostschutzmittel	1	Antifreezing admixture
Benzin	5	Gasoline
Diesel	2-3	Diesel
Alkohole	1	Alcohol

1 = keine Effekte	Für Dauerkontakt	1 = no effects	Permanent contact
2 = geringe Effekte	Kontakt zulässig	2 = few effects	Some contact
3 = mäßige Effekte	Kontakt zulässig	3 = medium effects	Some contact
4 = merkliche Effekte	Kontakt einschränken	4 = noticeable effects	Reduced contact
5 = starke Effekte	Nur kurzzeitigen Kontakt	5 = severe effects	Very brief contact
6 = extreme Effekte	Kontakt vermeiden	6 = extreme effects	Avoid contact

Die aufgeführten Materialeigenschaften gelten als Richtlinie. Kritische Anwendungen müssen von Seiten des Kunden praxisbezogen erprobt werden.

The listed material properties are considered as guideline. Critical application must be practically tested by the customer.

# Montageanleitung

## Mounting instructions

1. Drill a 1/2" hole in the post with 2" (± 10%) diameter at specified position.

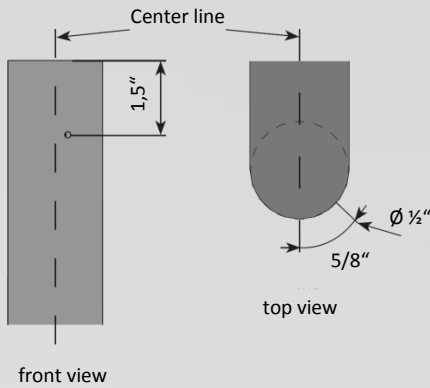

2. Lead the cable of the SENTIR edge through the hole.

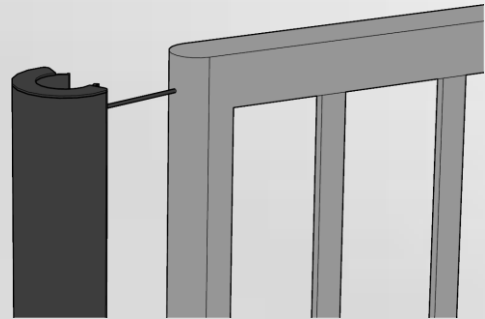

3. Clip and align the SENTIR edge onto post.

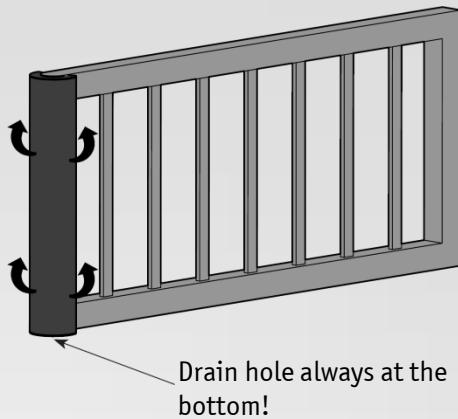

4. Predrill with 1/8" at a distance of 1" from the top. Drill further holes through the mounting tabs and the gate post every 12 inches.

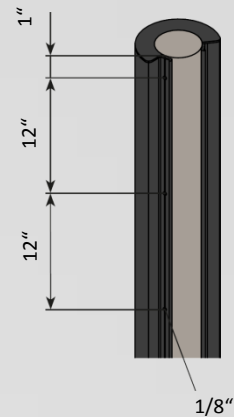

5. Screw SENTIR edge with #10 screws to the post. Screw through mounting tab into the post.

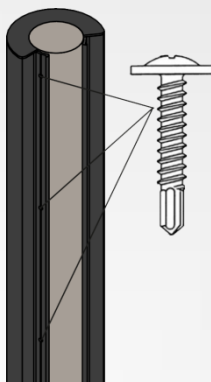

6. Connect the wire to the gate operator.

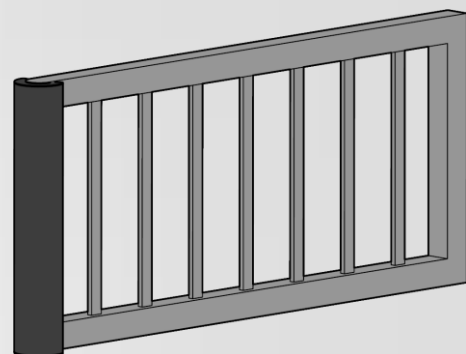

# Vorzüge im Überblick

## *Benefit overview*

- Optimiertes Schaltsystem  
(IP 65)  
*Optimized switching system  
(IP 65)*
- Optimale Verfügbarkeit durch eigene Extrusionsanlage  
*Best availability thanks to own extrusion line*
- Verbesserte Qualitätskontrolle für noch verlässlichere Produkte  
*Improved quality control for even more product reliability*
- Verbesserte Schaltresultate (auch  $> 45^\circ$ )  
*Enhanced switching results (also  $> 45^\circ$ )*
- Geeignet für Rohrfosten 2 inch (50,8mm)  
*Prepared for posts 2 inch (50.8mm)*
- UL 325 zertifiziert  
*UL 325 certified*
- Einsetzbar für diverse Tortypen  
*Usable for various types of doors, gates*
- Umweltfreundlicher Herstellungsprozess  
*Eco-friendly manufacturing process*



**Hauptsitz Europa**  
Headquarter Europe

ASO GmbH  
Hansastraße 52  
59557 Lippstadt

**Tel** +49 2941 9793-0  
**Fax** +49 2941 9793-299  
[www.asosafety.de](http://www.asosafety.de)  
[info@asosafety.com](mailto:info@asosafety.com)

**Hauptsitz USA**  
Headquarter USA

ASO Safety Solutions Inc.  
300 Roundhill Drive, Unit 6  
Rockaway, NJ 07866

**Phone** +1 973 5869600  
**Fax** +1 973 7844994  
[www.asosafetyus.com](http://www.asosafetyus.com)  
[sales-us@asosafety.com](mailto:sales-us@asosafety.com)