

USER'S GUIDE

Model CVC

Current & Voltage Calibrator

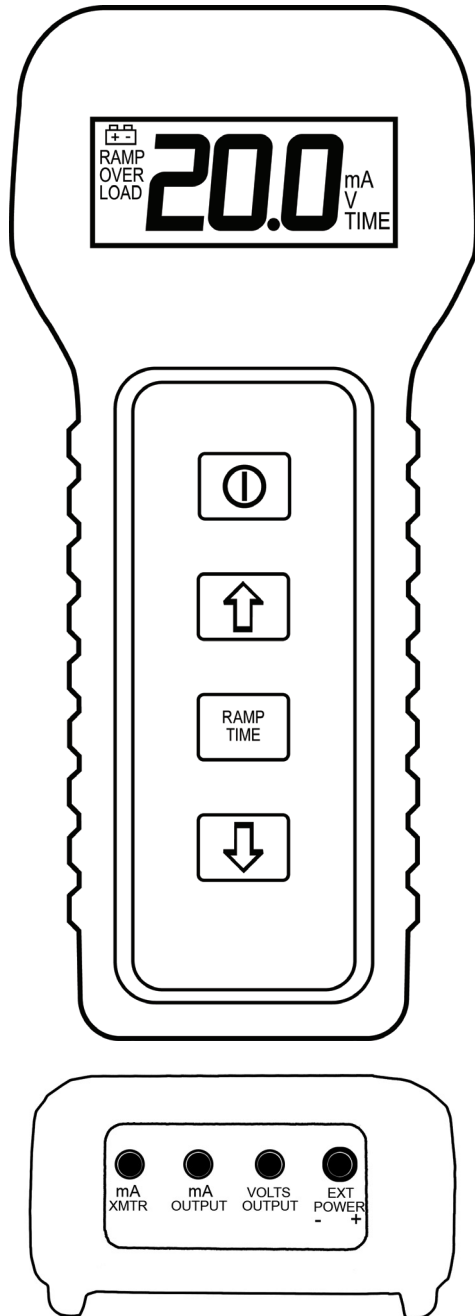

Specifications

OUTPUTS

Ranges

Current: 0.0 to 20.0mA DC in 1mA steps
Voltage: 0.0 to 10.0V DC in 1V steps

Accuracy at 25°C

Current: +/- 0.05mA DC
Voltage: +/- 0.05V DC

Load Impedance

Current: 300 ohms maximum
Voltage: 1000 ohms minimum

External mA Transmitter Source

Voltage: 12V minimum to 30V peak maximum

RAMPING

Manual

Anywhere in range

Auto

Values: User adjustable Min. & Max. values anywhere within range

Step Time: User adjustable from 1 to 20 seconds, in 1 second increments

DISPLAY

Numerical

LCD, 00.0 to 99.9, 0.59"H (15mm)

Annunciators

"RAMP", "OVER LOAD", "mA", "V", "TIME", and symbol for low battery

Blue Backlight

Energized with momentary side switch

ENVIRONMENT

Operating

32 to 122°F (0 to 50°C)

POWER

9V Battery

NEDA1604, JIS006P, or IEC6F22 (Duracell MN1604 or equivalent)
Up to 30 hours continuous use

Low Battery

Indicator comes on below approximately 7 volts

120 V AC

Plug-in 9V DC output supply for bench-top use

Auto Power Off

User adjustable delay time from 1 to 20 minutes after last key press
Can also be disabled

MECHANICAL

Dimensions

5.5"H x 2.5"W x 1.4"D
(140H x 63.5W x 35.6D mm)

Weight

6 oz (170 g)

Operating Instructions

POWER ON/OFF

Make sure that the battery is installed or the AC adapter is plugged into the EXT POWER jack. The AC adapter disconnects the internal battery.

To turn the CVC on, press and hold the upper red ON/OFF button for at least 2 seconds. The LCD annunciators will cycle and then hold steady when the CVC is turned on. Release the ON/OFF button within 5 seconds after cycling stops or the unit will turn off.

To turn off, press and hold the ON/OFF button for at least 5 seconds. The LCD annunciators will start to cycle when the CVC is turned off. Release the ON/OFF button as soon as the display starts to cycle or the unit will turn on again.

SELECTING OUTPUT MODE

Plug the test lead assembly into the appropriate output jack as shown below. If the test leads are plugged into the mA XMTR or mA OUTPUT jack, or no leads are plugged in, "mA" will turn on. If the load resistance is too high or the leads are left open, "OVERLOAD" will turn on. If the leads are plugged into the VOLTS OUTPUT jack, "V" will turn on. If the load resistance is too low or the leads are shorted, "mA" may stay on or turn on.

Fig 1. Voltage Output

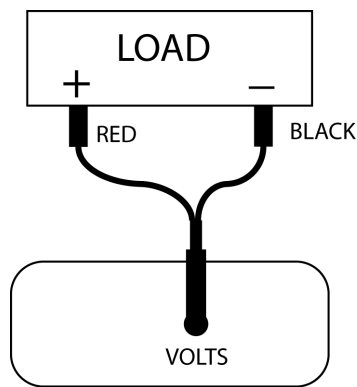

Fig. 2 mA Source Output

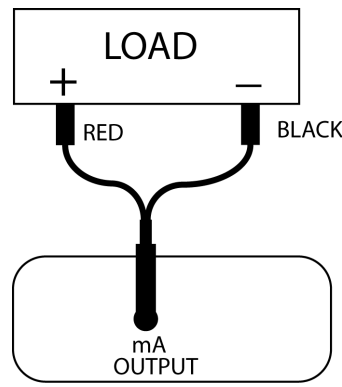
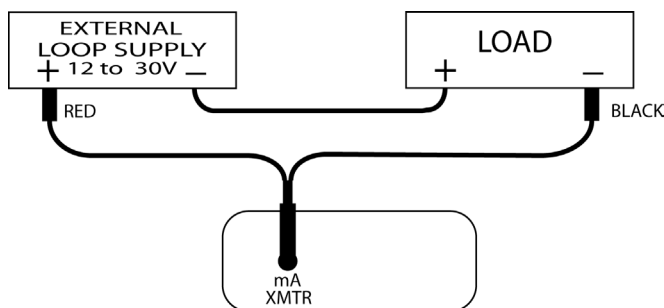

Fig 3. Simulate a 2-Wire mA Transmitter Loop With External 12 to 30V DC Supply. A similar connection can be used to extend output range of CVC beyond 300 ohms. A 24V source will allow CVC to source into an impedance of >1000 ohms.



MANUAL SELECTION OF OUTPUT LEVEL

To increase the output, press the \uparrow key. To reduce the output, press the \downarrow key. New output value will be displayed on the display.

AUTO RAMPING

The output is preprogrammed to ramp between 4 to 20 mA (or 2 to 10 V) and back in 1.0 mA (or 1.0 V) steps, with 5 seconds between each step. See below to change the ramp end points and step time interval.

To start ramping the output, press the RAMP/TIME key for 2 seconds. "RAMP" will turn on and the output will start ramping within the minimum and maximum values programmed into the CVC. It will start at the output value manually set on the CVC before the key is pressed.

To stop the ramping and return to manual mode, press the RAMP/TIME key again.

CHANGING THE AUTO RAMPING END POINTS AND STEP TIME

Press and hold the RAMP/TIME key, and immediately (within 2 seconds) press the \downarrow key without releasing the RAMP/TIME key until "RAMP" and "TIME" turn on. "mA" will turn off. Set the time duration for each step increment from 1.0 to 20.0 seconds, in 1.0 second increments by using the \uparrow and \downarrow keys.

To store the desired time interval, press the RAMP/TIME key again. "TIME" will turn off and the appropriate "mA" or "V" will flash. "RAMP" will remain on.

Set the first end point by using the \uparrow and \downarrow keys. To store the first end point, press the RAMP/TIME key again. The appropriate "mA" or "V" and "RAMP" will flash.

Set the second end point by using the \uparrow and \downarrow keys. To store the second end point and exit the programming mode, press the RAMP/TIME key again. The second value stored will be displayed along with the appropriate "mA" or "V".

SETTING THE AUTO POWER OFF DELAY TIME

With the unit ON, press and hold the RAMP/TIME key, and immediately (within 2 seconds) press the \uparrow key without releasing the RAMP/TIME key until "TIME" turns on. All other annunciators are off. Set the time delay from the last key press until the unit automatically turns OFF by using the \uparrow and \downarrow keys. The time delay can be set from 1.0 to 20.0 minutes in 1.0 minute increments. If the delay time is set to 00.0 minutes, the Auto Power Off Delay function is disabled. This is useful when the unit is used on a bench with the AC adapter.

To store the desired time delay, press the RAMP/TIME key again. "TIME" will turn off and the appropriate "mA" or "V" will turn on.

Warranty

This product is warranted to be free of defects in material and workmanship for one year from date of shipment under normal use and service. This warranty does not apply to batteries, lamps, sensors, and other wear items. This warranty does not apply to defects resulting from the action of the user such as misuse, improper wiring, operation outside of specification, alteration, accident, unauthorized repair, improper maintenance, or abnormal conditions of operation.

The manufacturer specifically disclaims any implied warranties of merchantability or fitness for any particular purpose and will not be liable for any direct, indirect, incidental or consequential damages. The manufacturer's total liability is limited to repair or replacement of the product.

If it should be necessary to return the product during or beyond the warranty period, contact customer service where purchased. The sender is responsible for shipping charges, freight, insurance and proper packaging to prevent damage in transit.

The warranty set forth above is inclusive and no other warranty, whether written or oral, is expressed or implied.