

High-Pressure Block Body Ball Valve - Type BBV22/23

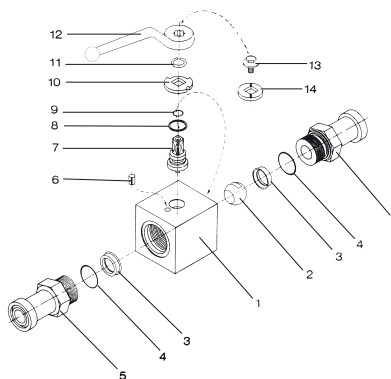
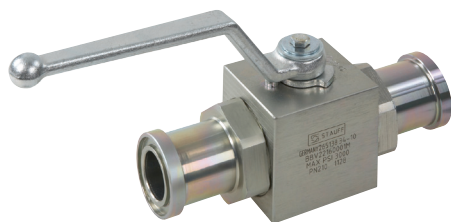

List of Components

No.	Qty.	Description
1	1	Housing
2	1	Ball
3*	2	Seat
4*	2	Connector O-Ring
5	2	Connector
6	1	Stop Pin
7	1	Stem
8*	1	Thrust Ring
9*	1	Stem O-Ring
10	1	Cam Plate
11	1	Snap Ring
12	1	Handle
13	1	Stem Screw
14	1	Flow Indicator

* Included in seal kit

Characteristics

Two-way high-pressure block body ball valves designed for use as on/off devices for hydraulic applications

Standard Construction

- Block body design for in-line assembly
- Supplied with lever

Standard Materials

- Body: Carbon Steel, zinc/iron-plated
- Ball: Carbon Steel, hard chrome-plated
- Stem: Carbon Steel
- Lever: Zinc
- Ball seat: Delrin® (POM)
- O-rings: FPM (Viton®)

Standard Connections Styles / Sizes

- 3000 PSI (code 61) SAE split flange connectors
- 6000 PSI (code 62) SAE split flange connectors
- Standard and extended adapter lengths

Pressure Range

- Pressure range: up to 420 bar / 6000 PSI (depending on size and material combination of the ball valve)

Please note: The final maximum working pressure is determined by flange and pipe/tubing rating.

Temperature Range

- Operating temperature range: -20°C ... +100°C / -4°F ... + 212°F

Options / Accessories

- Flanges and flange kits (see Flanges section)
- Alternative lever designs/materials (see page F98)
- Locking devices (see pages F99-F101)
- Pneumatic actuator packages (see page F102)
- Limit switches (see page F102)
- Stainless Steel body
- Stainless Steel ball and stem
- Special ball seat and O-ring materials available for lower/higher temperatures and more aggressive media
- Additional assembling threads / holes (see page F103)
- Electrical actuators available on request. Please consult STAUFF for further information.

Order Codes

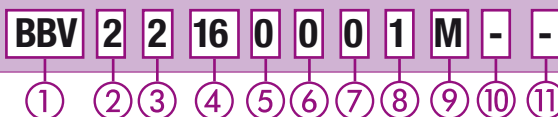

① Type

High-Pressure Block Body Ball Valve **BBV**

② Number of Ports

Two Ports (Two-Way Ball Valve) **2**

③ Connection Style

3000 PSI (Code 61) SAE Split Flange Connectors (Standard Adaptor Length)	2
3000 PSI (Code 61) SAE Split Flange Connectors (Extended Adaptor Length)	2X
6000 PSI (code 62) SAE Split Flange Connectors (Standard Adaptor Length)	3
6000 PSI (code 62) SAE Split Flange Connectors (Extended Adaptor Length)	3X

Please consult STAUFF for alternative connection styles.

④ Connection Size

STAUFF Size (according to dimension table)		
08	12	16

Please consult STAUFF for alternative connection sizes.

⑤ Body Material / Surface Finishing

Carbon Steel, zinc/iron-plated	0
Stainless Steel V4A (AISI 316Ti)	1

Alternative materials / surface finishings are available upon request. Consult STAUFF for further information.

⑥ Ball / Stem Material

Ball: Carbon Steel, hard chrome-plated	0
Stem: Carbon Steel	0
Ball / Stem: Stainless Steel V4A (AISI 316Ti)	1

Alternative materials / surface finishings are available upon request. Consult STAUFF for further information.

⑦ Ball Seat Material

Delrin® (POM)	0
---------------	----------

Alternative materials are available upon request. Consult STAUFF for further information.

⑧ O-Ring Material

NBR (Buna-N®)	0
FPM (Viton®)	1

Alternative materials are available upon request. Consult STAUFF for further information.

⑨ Manufacturing Code

Manufacturing code for all connection styles	M
Manufacturing code for high-pressure version of 6000 PSI Series (STAUFF Size 16)	H

⑩ Lever Options

Supplied with standard lever (according to table)	-
Supplied without lever	-0

Alternative levers can be ordered separately. Please see page F98 for further information.

⑪ Accessories / Options

Supplied without accessories	-
Supplied with Locking Device LD1	-LD1
Supplied with Locking Device LD2	-LD2
Supplied with Locking Device LD3 (standard*)	-LD3
Supplied with Locking Device LD4	-LD4
Supplied with Double-Acting Pneumatic Actuator (Please add size **)	-EDA**
Supplied with Single-Acting Pneumatic Actuator (Please add size **)	-ESA**
Supplied with Limit Switch in open position	-LS-0
Supplied with Limit Switch in closed position	-LS-C
Supplied with Limit Switch in open and closed position	-LS-OC

*1 LD4 is the standard locking device option for the high-pressure version (manufacturing code H). Please see page F99 for further information.

High-Pressure Block Body Ball Valve - Type BBV22/23 3000 PSI SAE Split Flange Connection (ISO 6162-1)

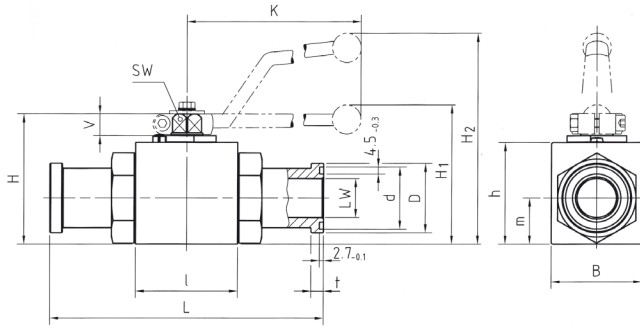

When ordering the standard option as indicated in the table below, the following materials will be supplied:

- Body, ball and stem: Carbon Steel
- Lever: Zinc
- Ball seat: Delrin® (POM)
- O-rings: FPM (Viton®)

3000 PSI Series (Code 61) - Standard Adaptor Length

STAUFF Size	SAE Flange Size	Nominal Size DN	Dimensions (mm/in)														Nom. Pressure (bar/PSI)	Weight (kg/lbs)	Order Codes (Standard Option)	
			LW	L	I	B	H	h	m	V	SW	K	d ¹	D ²	t ³	H1	H2			
08	1/2	13	13	151	48	35	54	40	19	11	9	115	25,5	30,2	6,8		89	345	0,85	BBV22080001M
			.51	5.94	1.89	1.38	2.13	1.57	.75	.43	.35	4.53	1.00	1.19	.27		3.50	5000	1.87	
12	3/4	20	19	162	62	49	75	57	24,5	14	14	200	31,9	38,1	6,8	79		345	1,87	BBV22120001M
			.75	6.38	2.44	1.93	2.95	2.24	.96	.55	.55	7.87	1.26	1.50	.27	3.11		5000	4.11	
16	1	25	25	178	66	58	83	65	29,5	14	14	200	39,8	44,4	8,1	87		345	2,70	BBV22160001M
			.98	7.01	2.60	2.28	3.27	2.56	1.16	.55	.55	7.87	1.57	1.75	.32	3.43		5000	5.94	

3000 PSI Series (Code 61) - Extended Adaptor Length

STAUFF Size	SAE Flange Size	Nominal Size DN	Dimensions (mm/in)														Nom. Pressure (bar/PSI)	Weight (kg/lbs)	Order Codes (Standard Option)	
			LW	L	I	B	H	h	m	V	SW	K	d ¹	D ²	t ³	H1	H2			
08	1/2	13	13	170	48	35	54	40	19	11	9	115	25,5	30,2	6,8		89	345	0,89	BBV22X080001M
			.51	6.69	1.89	1.38	2.13	1.57	.75	.43	.35	4.53	1.00	1.19	.27		3.50	5000	1.96	
12	3/4	20	19	200	62	49	75	57	24,5	14	14	200	31,9	38,1	6,8	79		345	2,00	BBV22X120001M
			.75	7.87	2.44	1.93	2.95	2.24	.96	.55	.55	7.87	1.26	1.50	.27	3.11		5000	4.40	
16	1	25	25	215	66	58	83	65	29,5	14	14	200	39,8	44,4	8,1	87		345	2,85	BBV22X160001M
			.98	8.46	2.60	2.28	3.27	2.56	1.16	.55	.55	7.87	1.57	1.75	.32	3.43		5000	6.27	

Please note: The final maximum working pressure is determined by flange and pipe/tubing rating.

High-Pressure Block Body Ball Valve - Type BBV22/23 6000 PSI SAE Split Flange Connection (ISO 6162-2)

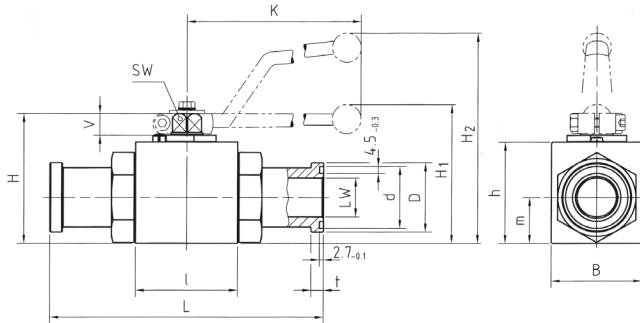

When ordering the standard option as indicated in the table below, the following materials will be supplied:

- Body, ball and stem: Carbon Steel
- Lever: Zinc
- Ball seat: Delrin® (POM)
- O-rings: FPM (Viton®)

6000 PSI Series (Code 62) - Standard Adaptor Length

STAUFF Size	SAE Flange Size	Nominal Size DN	Dimensions (mm/in)														Nom. Pressure (bar/PSI)	Weight (kg/lbs)	Order Codes (Standard Option)	
			LW	L	I	B	H	h	m	V	SW	K	d ¹	D ²	t ³	H1	H2			
08	1/2	13	13	151	48	35	54	40	19	11	9	115	25,5	31,8	7,9		89	420	0,90	BBV23080001M
			.51	5.94	1.89	1.38	2.13	1.57	.75	.43	.35	4.53	1.00	1.25	.33		3.50	6000	1.98	
12	3/4	20	19	174	62	49	75	57	24,5	14	14	200	31,9	41,3	8,9	79		420	1,95	BBV23120001M
			.75	6.85	2.44	1.93	2.95	2.24	.96	.55	.55	7.87	1.26	1.63	.38	3.11		6000	4.29	
16	1	25	25	198	66	58	83	65	29,5	14	14	200	39,8	47,6	9,6	87		315	3,00	BBV23160001M
			.98	7.80	2.60	2.28	3.27	2.56	1.16	.55	.55	7.87	1.7	1.87	3.78	3.43		4500	6.60	
16	1	25	25	206	74	70	88	70	34,5	14	14	200	39,8	47,6	6,9	92		420	3,00	BBV23160001H
			.98	8.11	2.91	2.76	3.46	2.76	1.36	.55	.55	7.87	1.7	1.87	3.78	3.43		6000	6.60	

6000 PSI Series (Code 62) - Extended Adaptor Length

STAUFF Size	SAE Flange Size	Nominal Size DN	Dimensions (mm/in)														Nom. Pressure (bar/PSI)	Weight (kg/lbs)	Order Codes (Standard Option)	
			LW	L	I	B	H	h	m	V	SW	K	d ¹	D ²	t ³	H1	H2			
08	1/2	13	13	180	48	35	54	40	19	11	9	115	25,5	31,8	7,9		89	420	1,00	BBV23X080001M
			.51	7.09	1.89	1.38	2.13	1.57	.75	.43	.35	4.53	1.00	1.25	.33		3.50	6000	2.20	
12	3/4	20	19	200	62	49	75	57	24,5	14	14	200	31,9	41,3	8,9	79		420	2,10	BBV23X120001M
			.75	7.87	2.44	1.93	2.95	2.24	.96	.55	.55	7.87	1.26	1.63	.38	3.11		6000	4.62	
16	1	25	25	250	66	58	83	65	29,5	14	14	200	39,8	47,6	9,6	87		315	3,15	BBV23X160001M
			.98	9.84	2.60	2.28	3.27	2.56	1.16	.55	.55	7.87	1.7	1.87	3.78	3.43		4500	6.93	
16	1	25	25	250	74	70	88	70	34,5	14	14	200	39,8	47,6	6,9	92		420	3,15	BBV23X160001H
			.98	9.84	2.91	2.76	3.46	2.76	1.36	.55	.55	7.87	1.7	1.87	3.78	3.43		6000	6.93	

Please note: The final maximum working pressure is determined by flange and pipe/tubing rating.