

Mounting Quick-Release Vises

Quick-Release Bench Vises can be mounted in variety of positions and on many different styles of benches. The key to successful installation is careful planning and preparation. Installed properly, your vise will give a lifetime of daily service.



WISE POSITION

Assuming you're right handed, typical mounting positions would be either toward the left of the front edge of your bench, or the right end of your bench. Carvers will probably find the end position most useful, as will those who clamp wide, flat work like doors and large panels. For general purpose work, the bench's front edge is probably the best option. Just be sure the vise doesn't interfere with the bench's legs or aprons. Also, take into account that the vise will have wooden jaw liners (described later) that stick out past the edge of the vise. Most people prefer to have the ends of the jaw liners flush with a corner of the bench top, so take that into consideration when you locate your vise.

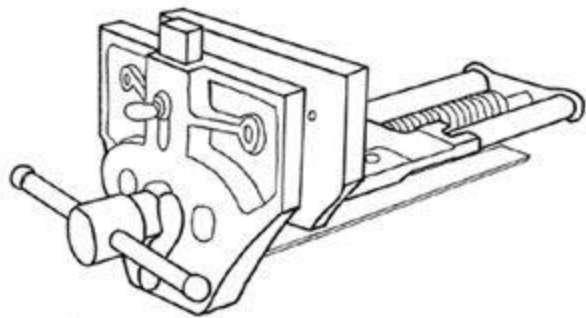

MAKING A SPACER BLOCK

For most bench tops, you'll need to mount a spacer between the vise carriage and the underside of the bench top. You'll want the vise's cast iron jaws set about 1/2" below the top surface of the bench to protect your tools from accidental contact. This 1/2" measurement is not critical. You may have to adjust it in order to make your spacer material fit. With the vise held approximately 1/2" below the top surface of your bench, measure the distance between the vise carriage and the underside of the bench. This distance is the thickness of your spacer. We recommend building the spacer from MDF, particleboard or Masonite, all of which are relatively crush-resistant.

MORTISING THE REAR JAW

Once you've determined the thickness of the spacer block, you'll need to mortise the rear jaw into the edge of your bench top. Put the bench top on edge and secure it well. Temporarily clamp the vise with the spacer blocks to the bench top. With a pencil, mark around the rear jaw onto the edge of the bench. Remove the vise. Make the top line about a 1/16" to 1/8" higher so there'll be a gap between the top of the jaw and the mortise. This gap will allow seasonal movement to occur. The depth of the mortise will be the thickness of the rear jaw. On some vise models, you may also have to remove additional material to accommodate any reinforcement webbing cast into the vise's carriage.

JAW LINERS

Wooden liners expand your vise's holding capacity and prevent your work from being marred by the cast iron jaws. Any hardwood will work as a liner material. The front jaw liner should be at least 1 5/8" thick to prevent deflection and so you can drill holes in the top of the liner for bench dogs if you like. The rear jaw only needs to be 3/4 – 1" thick because it will be supported by the edge of the bench.

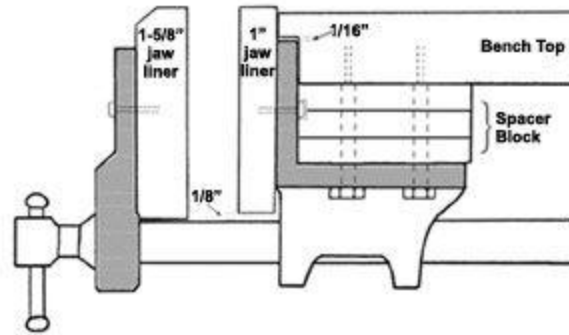

For small vises (7" wide), make the liner length 12 – 14". Medium sized vises (9" wide) can handle liners 14-16" in length. You can go up to 18" long for large vises (10" wide). Anything longer will cause excessive racking and shorten the life of your vise. In the end, the jaw liners need to be at least 1/8" above the vise's guide posts to allow for seasonal movement and flush with the top of the bench. However you choose to attach your jaw liners to your vise, make they can be easily removed if they become damaged or warped. At this point, close the vise and make sure the liners mate up acceptably and shim if necessary. Remember, the jaws of these vises toe in where they meet at the top and should do so after the liners are installed.

MOUNTING THE VISE

Depending on your bench's top thickness, you have two mounting options. If your top is at least 2" thick, lag screws work fine. With washers attached, run the lags up from underneath the vise's carriage, through the spacer block and into the underside of the bench top. If your top is less than 2" thick, install carriage bolts right through the bench top and secure them with nuts and washers under the vise's carriage. Be sure to countersink the heads of the bolts below the surface of the top to prevent tool or work damage. Plug or fill the holes by any method that pleases you. With either mounting technique, you'll want to occasionally check the hardware to be sure it isn't working loose. As for maintenance, lubricate the threads of the main screw with light oil and wax the guide rods occasionally.

These instructions are for use with cast iron British-style quick-release vises. They have been manufactured by many companies including Record, Anant, Groz, Eclipse and others; but most are based on the same pattern. These instructions should work for all of these vises. However, your vise and bench application may require some modifications to these instructions.