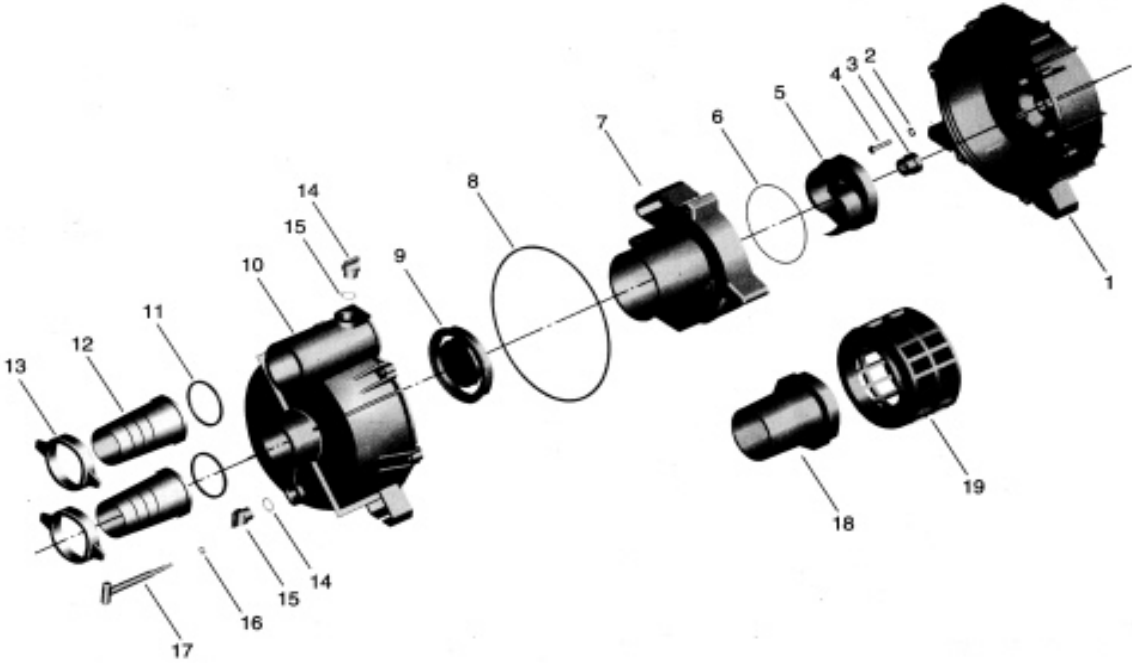

GASOLINE TRASH PUMP, MODEL: GTP-50

No.	P/N	Description	Qty.	Diagram
1	50GTP01	Pump inner housing	1	
2	50GTP02	Washer	4	
3	50GTP03	Mechanical Seal	1	
4	50GTP04	Bolt	4	
5	50GTP05	Impeller	1	
6	50GTP06	Inner O-ring	1	
7	50GTP07	Spiral case	1	
8	50GTP08	Outer Body O-ring	1	
9	50GTP09	Flapper	1	
10	50GTP10	Pump outer housing	1	
11	50GTP11	Intake/Discharge Seal	2	
12	50GTP12	Intake/Discharge Fitting	2	
13	50GTP13	Joint	2	
14	50GTP14	Seal, Drain Plug	2	
15	50GTP15	Drain Plug	2	
16	50GTP16	O-ring	5	
17	50GTP17	Outer Bolt	5	
18	50GTP18	Strainer 1	1	
19	50GTP19	Strainer 2	1	
20	50GTP20	Frame	2	
21	30GTP0	Pump less engine, less frame		

© Yamakoyo Machinery Co., Ltd 2005