

# Service Schematic

NOTICE - PROPRIETARY INFORMATION: THIS SERVICE SCHEMATIC AND ITS CONTENTS ARE WHOLLY OWNED BY HYDRO-GEAR OF SULLIVAN, IL, AND MAY NOT BE USED, DISCLOSED, PUBLISHED OR REPRODUCED WITHOUT THE WRITTEN CONSENT OF HYDRO-GEAR.

## EZT SERVICE DRAWING, 1" AXLE

**NOTES:**

- 1. BRAKE AND CONTROL ARM CAN BE ON EITHER SIDE.
- 2. LH SIDE SHOWN. RH SIDE IS A MIRROR IMAGE.
- 3. 52-SEAL KIT, P/N 70853, CONTAINS THE FOLLOWING ITEMS:  
SEALS: 10,13,20,33,51  
RETAINING RINGS: 14,16,18,31,34,37,45

**ITEMS NOT SHOWN**

- 11 - OIL, 20W-50 (56oz)
- 58 - SEALANT TUBE

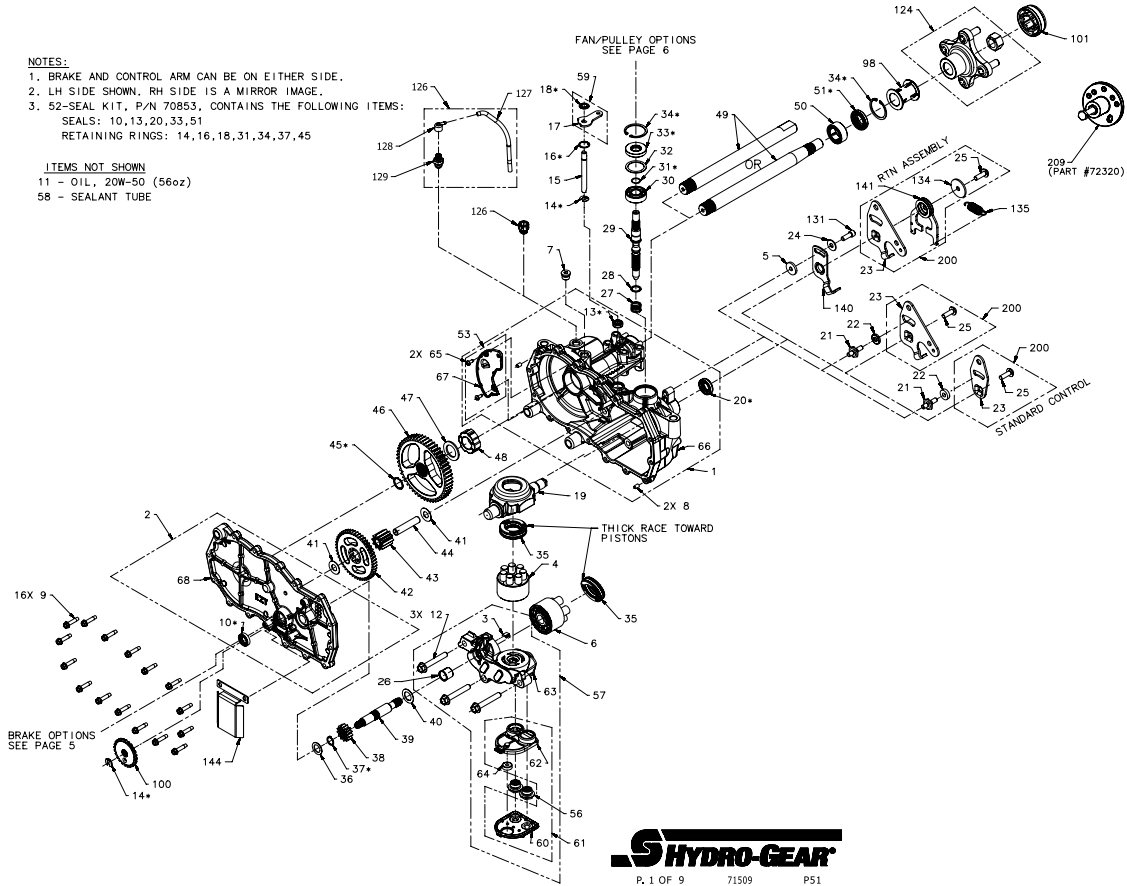

**ZC-AMBB-2L7B-1WPX**

## Service Schematic

#	PART #	DESCRIPTION	QTY	Note
1	71098	KIT, MAIN HOUSING - RH	1	
2	70983R	KIT, SIDE HOUSING - RH	1	
4	70723	ASSY, BLOCK 7 PISTON	1	
5	54315	SPACER 0.320 ID X 1.005 OD X 0.1495 THK	1	
6	70331	KIT, BLOCK, 10CC CYLINDER	1	
7	9005110-5600	PLUG 9/16-18 METAL	1	
9	53246	SCREW 1/4-20 X 1.125 HEX WASHER	16	
15	51625	ROD BYPASS	1	
19	51048	TRUNNION, SWASHPLATE	1	
24	44130	WASHER .34 X .88 X .06	1	
27	2003014	SPRING, BLOCK	1	
28	2003017	WASHER .59 X .79 X .04 FLAT	1	
29	51062	SHAFT INPUT	1	
30	50315	BEARING 17X40X12 BALL OPEN 6203	1	
32	50951	WASHER 1.23 X 1.57 X .04	1	
35	50551	BEARING 30X52X13 BALL THRUST	2	
36	44371	WASHER .63 X 1.0 X .05 FLAT	1	
37	44145	RETAINING RING, MOTOR SHAFT	1	
38	51130	GEAR, 13T PINNION	1	
39	51845	SHAFT MOTOR	1	
40	51069	WASHER .71 X 1.16 X .04 FLAT	1	
41	50132	WASHER .51 X 1.10 X .03 FLAT	2	
42	51129	GEAR, 10T/48T	1	
43	51043	GEAR, 10T JACKSHAFT	1	
44	55710	JACK SHAFT (PIN)	1	
46	52541	GEAR, 52T BULL	1	
47	52532	WASHER 1.013 X 1.750 X .105 FLAT	1	
48	52542	SLEEVE BEARING (INBOARD)	1	
49	52545	SHAFT 1.00 X 11.70 DD AXLE	1	
50	51517	BUSHING 1.003X1.571X.625	1	
52	70853	KIT, SEALS AND RETAINING RINGS	1	
10		SEAL. LIP .625 X 1.000 X .250	1	
		SEAL. LIP .50 X .88 X .25	1	
13		SEAL. LIP .375 X .75 X .25	1	
14		RING RETAINING .375 EXT	2	
16		RING RETAINING .750 INT	1	
18		RING RETAINING .375 EXT (PUSHNUT)	1	
20		SEAL. LIP 18 X 32 X 7	1	
31		RING RETAINING WIRE .561 ID	1	
33		SEAL LIP 17 X 40 X 7	1	
34		RING RETAINING	2	
37		RING RETAINING	1	
45		RING SPIRAL RETAINING	1	
51		SEAL LIP 1.00 X 1.57 X .25	1	
		SEAL LIP .375 X .75 X .25	1	
53	70868R	KIT, EXPANSION PLATE RH	1	

Service Schematic

# Service Schematic

#	PART #	DESCRIPTION	QTY	Note
57	71530	KIT, CENTER SECTION W/ FILTER - RH	1	
(63)		CENTER SECTION, RH, 7P	1	
(3)		PLATE, BYPASS	1	
(26)		BUSHING, .711 X .789 X .778	1	
(12)		BOLT, HEX FLANGE 3/8-24 X 2.5	3	
(60)		ASSEMBLY, COVER	1	
(62)		FILTER, BASE	1	
(64)		MAGNET	1	
(56)		CHECK PLUG ASSEMBLY, .027, WASHER	2	
58	50928	SEALANT TUBE	1	
59	70891	KIT, BYPASS ARM	1	
61	71497	KIT, FILTER	1	
(60)		ASSEMBLY, COVER	1	
(62)		FILTER, BASE	1	
(64)		MAGNET	1	
100	51635	DISC, COG BRAKE	1	
126	55995	ASSEMBLY, FITTING 9/16-18 BREATHER	1	
131	71341	KIT, RTN SCREWS	1	
135	52401	SPRING EXT .63 X 2.05	1	
140	51945	ARM, NEUTRAL RIGHT	1	
200	71588	KIT, RTN, BIDIRECTIONAL	1	
209	72320	KIT HUB PULLER	1	