



M1108J

ITEM NUMBER: 1108, 1109, 1114

SERIAL NUMBER: _____

Owner's Manual

Instructions for Assembly, Testing, Operation, Servicing, & Storage

22, 30, 37-Ton Log Splitters: Outdoor hydraulic powered machine that splits wood logs.

⚠ WARNING

READ and UNDERSTAND this manual completely before using log splitter.

All operators of this equipment must read and completely understand all safety information, operating instructions, maintenance and storage instructions. Failure to properly operate and maintain the log splitter could result in serious injury to the operator and bystanders from moving parts that can crush or cut, flying objects, burns, fire or explosion, escaping high pressure hydraulic fluid, or carbon monoxide poisoning in particular, be aware of the following hazards.

Crush and Cut Hazards

Moving parts can crush and cut hands and fingers. Keep hands clear of endplate, wedge, logs, and log strippers while splitting.

High Pressure Hydraulic Fluid Hazards

High fluid pressures and temperatures are developed in hydraulic log splitters. Hydraulic fluid escaping through even a pin-size hole opening can puncture skin and cause severe blood poisoning. Inspect hydraulic system regularly for possible leaks. Never check for leaks with your hand while the system is pressurized. Seek medical attention immediately if injured by escaping fluid.

Fire Hazards

- If your log splitter is intended for use near an ignitable forest, brush, or grassy covered land, the engine exhaust should be equipped with a spark arrestor. See the "Specifications" section of this manual to determine if your splitter already has a spark arrestor. If not equipped, call NorthStar Product Support for ordering information.
- Keep a fire extinguisher with you that is rated for ordinary combustibles and flammable liquids.

STOP!

ADD OIL TO ENGINE BEFORE USING: Engine is shipped without oil. DO NOT start log splitter without first adding oil.

ADD HYDRAULIC OIL: Your log splitter was shipped without hydraulic oil. Refer to Periodic Maintenance section of this manual for instructions on filling the hydraulic reservoir

INSPECT COMPONENTS: Closely inspect to make sure no components are missing or damaged.

See Initial Unpacking & Set-up for instructions and for whom to contact to report missing or damaged parts.

Any Questions, Comments, Problems or Parts Orders

Call NorthStar Product Support 1-800-270-0810

Hazard Signal Word Definitions





	<p>This is the safety alert symbol. It is used to alert you to potential personal injury hazards. Obey all safety messages that follow this symbol to avoid possible injury or death.</p>
	<p>DANGER (red) indicates an imminently hazardous situation which, if not avoided, will result in death or serious injury.</p>
	<p>WARNING (orange) indicates a potentially hazardous situation which, if not avoided, could result in death or serious injury.</p>
	<p>CAUTION (yellow) indicates a potentially hazardous situation which, if not avoided, may result in minor or moderate injury.</p>
	<p>CAUTION (yellow) used without the safety alert symbol indicates a potentially hazardous situation which, if not avoided, may result in property damage.</p>

fig01453

Table of Contents

About Your Log Splitter.....	4
Safety Label Locations	5
Machine Components Identification	7
Initial Set-up	8
Optional 4-Way Wedge Wings	10
Moving & Towing to the Job Site	11
Before Each Use:	
Step One: Inspection/Maintenance.....	14
Step Two: Refueling.....	16
Step Three: Work site Selection & Set-up	17
Splitting Operation	19
Storage.....	24
Periodic Maintenance	25
Troubleshooting.....	26
Specifications	27
Parts Breakdown – Exploded View.....	28
Summary of Important Safety Information for Operation	30
Assembly Instructions	35

About Your Log Splitter

Thank you for purchasing your NorthStar log splitter!

About Your Log Splitter:

This log splitter is a machine designed to split wood logs using a hydraulically powered moving wedge. The log splitter's gasoline engine is used to pressurize the hydraulic system.

This log splitter is designed to split logs *lengthwise with the grain only*.

Your splitter can be used in either a vertical or horizontal splitting position:

- When the splitter is set up to operate in the horizontal splitting position, a log is placed on the horizontal beam and the wedge moves horizontally into the end of the log to split it.
- When the splitter is set up to operate in the vertical splitting position, the log is placed on the endplate, upright on its end, and the wedge moves down into the top of the log to split it.

The horizontal splitting position is used for lighter logs that can be easily loaded onto the beam. The vertical splitting position is used for heavier logs that are difficult to load onto the beam.

The technical specifications for your log splitter are provided in the Specifications section of this manual.

WARNING

This log splitter uses a high-pressure hydraulic system to generate a very strong splitting force.

Read the manual completely before using the machine to understand how to safely operate and maintain it.

Follow all safety precautions presented throughout this manual. A summary of important safety information can be found at the end of this manual.

Contact NorthStar Product Support at 1-800-270-0810 for any questions about the appropriate use of this log splitter and/or optional accessories.

Warranty Registration:

Please fill out and submit the warranty registration card so that we have your contact information for any future product literature or replacement parts you may need.

Attention: All Rental Companies and Private Owners who loan this equipment to others!

All persons to whom you rent/loan the log splitter must have access to and read this manual. Keep this owner's manual with the splitter at all times and advise all persons who will operate the machine to read it. You must provide instruction on how to safely operate the splitter and remain available to answer any questions a renter/borrower might have.

Safety Label Locations

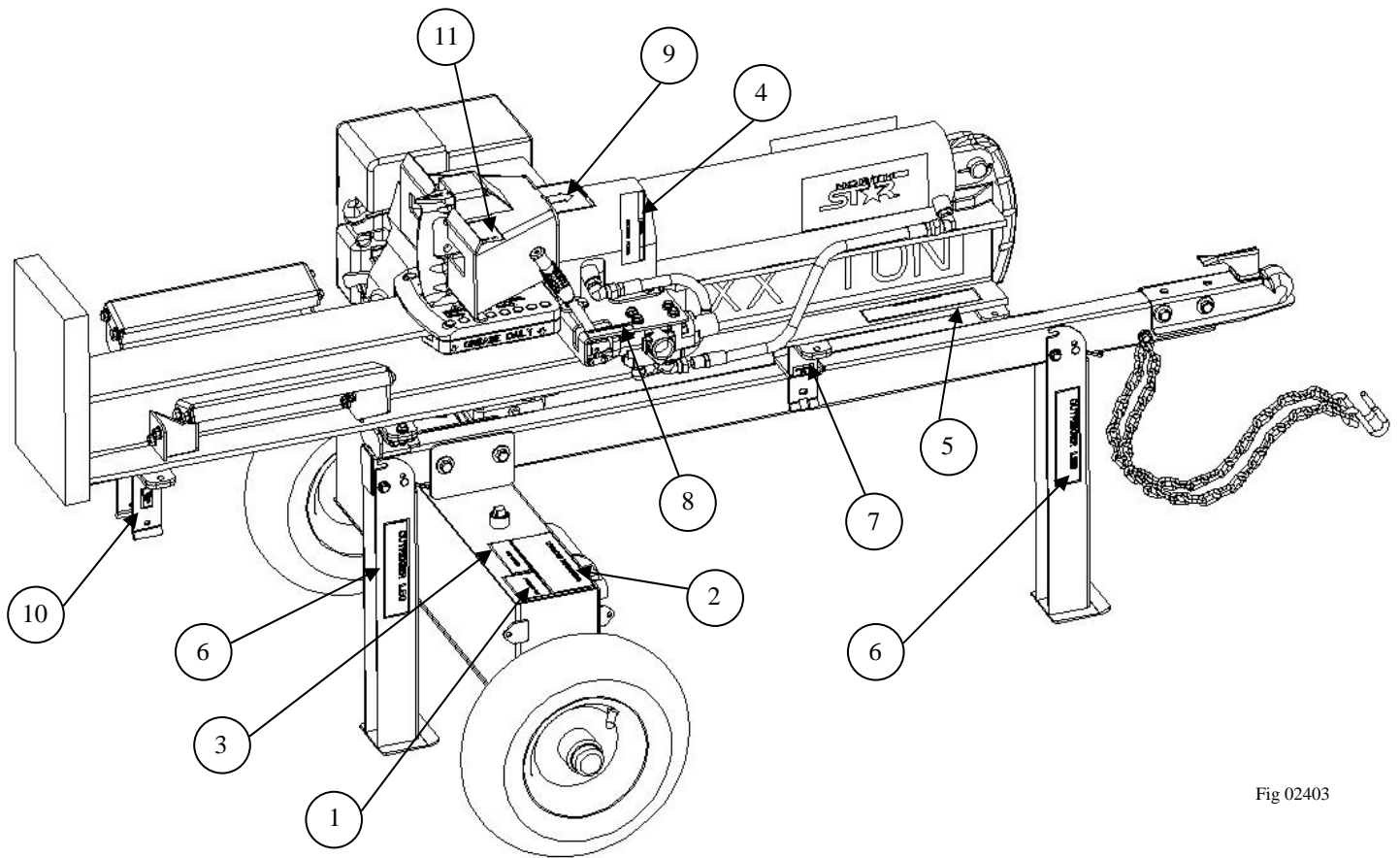

Fig 02403

Reference #	Part #	Description
1	39259	Warning Decal
2	777887	Splitter Operating Instruction Decal
3	777890	Fire Hazard Warning Decal
4	777891	Hydraulic Fluid Warning Decal
5	777892	Moving/Towing Decal
6	778593	Outrigger Leg Decal
7	778597	Horizontal Lock Decal
8	778609	Control Decal
9	778610	Log Splitter Warning Decal
10	778714	Vertical Lock Decal
11	778717	Log Stripper Decal

Always make sure safety labels are in good condition. If a safety label is missing or not legible, order new labels or unsafe operation could result.

Safety Label Locations

1

⚠ WARNING
POISONOUS GAS
 This product's use gives off carbon monoxide, an odorless gas that can kill you.
 • ONLY use outdoors and away from air intakes.
 • NEVER use inside homes, garages, or sheds. EVEN IF you run a fan or open doors and windows.
 See product manual for more details.



©2005 Northern Tool + Equipment Co. 1-800-270-0810 PN 39259

9

⚠ WARNING
 Moving parts can crush and cut. Pieces can fly out while splitting. Follow safety rules for operating the log splitter or serious injury could result.
 • READ the Owner's Manual completely before operating.
 • Only one person should operate the log splitter. If an assistant is helping to load logs, the operator should not actuate controls until the assistant is at least 10 ft away.
 • Stay in the designated OPERATOR POSITION while actuating the controls.
 • Split wood in direction of the grain only.
 • Hold bark side of logs when loading.
 • Keep hands away from wedge, endplate/ram, and partly split logs.
 • Never leave log splitter unattended during operation.
 • Stay off slopes and slippery surfaces.
 See additional safety rules in the Owner's Manual.

©2006 Northern Tool + Equipment Co. 1-800-270-0810 PN 778610

4

⚠ WARNING
ESCAPING HIGH PRESSURE HYDRAULIC FLUID HAZARD
 High fluid pressures and temperatures are developed in the hydraulic system. Hydraulic fluid escaping through even a pin-size hole opening can puncture skin and cause blood poisoning.
 • Inspect hydraulic system regularly for leaks
 • Never check for leaks with your hand while system is pressurized.
 • Seek medical attention immediately if injured by escaping fluid.



©2005 Northern Tool + Equipment Co. 1-800-270-0810 PN 777891

11

LOG STRIPPER
RETRACT WEDGE TO REMOVE STUCK WOOD

⚠ WARNING
PINCH POINT
 Keep hands clear of wedge and log stripper

©2006 Northern Tool + Equipment Co. 1-800-270-0810

2

OPERATING INSTRUCTIONS

GENERAL

- Stay in the OPERATOR POSITION while actuating controls.
- Never actuate controls until the helper is 10ft away from log splitter, including any helpers assisting to load logs.
- Wear eye protection, hearing protection, snug fitting gloves, and safety shoes or heavy boots. No loose or dangling apparel.

SETTING UP

- Place log splitter on dry, level ground.
- Secure splitter for unintended movement.
- Place splitter in horizontal or vertical position.
- Start engine

SPLITTING LOG

- Position log on beam, against endplate.
- Move split control to extend wedge and split log.
- Release split control to stop wedge.
- Move split control to return wedge.
- Remove split wood from work area.

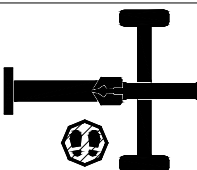

Operator Position - horizontal

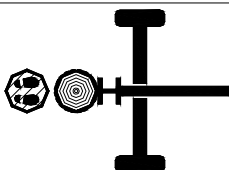

Operator Position - vertical

©2005 Northern Tool + Equipment Co. 1-800-270-0810 PN 777887

5

MOVING/TOWING INSTRUCTIONS

Moving log splitter by hand:

- Lock beam in horizontal position (tip-up models only).
- Lock towbar leg in DOWN position.
- Lock support leg in UP position (if equipped)
- Do not attempt to move log splitter up or down slope by hand.

Towing log splitter:

- Latch coupler securely to class 2 or higher hitch with 2" ball.
- Lock tow bar leg and support leg (if equipped) in the UP position.
- Attach safety chains to tow vehicle.
- Close fuel shut-off valve on engine (if equipped)
- Do not tow faster than 45 mph. Higher speeds can cause loss of control.
- Check local, state, and federal requirements before towing on public roads.

©2005 Northern Tool + Equipment Co. 1-800-270-0810 PN 777892

8

SPLIT CONTROL LEVER OPERATION

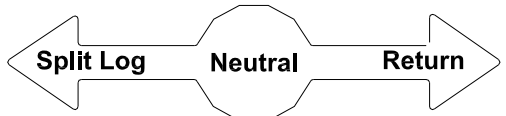

6

OUTRIGGER LEG
 LOCK BOTH OUTRIGGER LEGS IN THE DOWN POSITION BEFORE SPLITTING

3

⚠ WARNING
FIRE HAZARD
 Hot exhaust can ignite dry brush, trees, or grass.
 • Equip engine with a spark arrestor if you will be using near ignitable forest, brush or grassy covered land.
 • Keep a fire extinguisher on hand that is rated for ordinary combustibles & flammable liquids.



©2005 Northern Tool + Equipment Co. 1-800-270-0810 PN 777890

7

HORIZONTAL LOCK

PN 778597

10

VERTICAL LOCK

PN 778714

Machine Component Identification

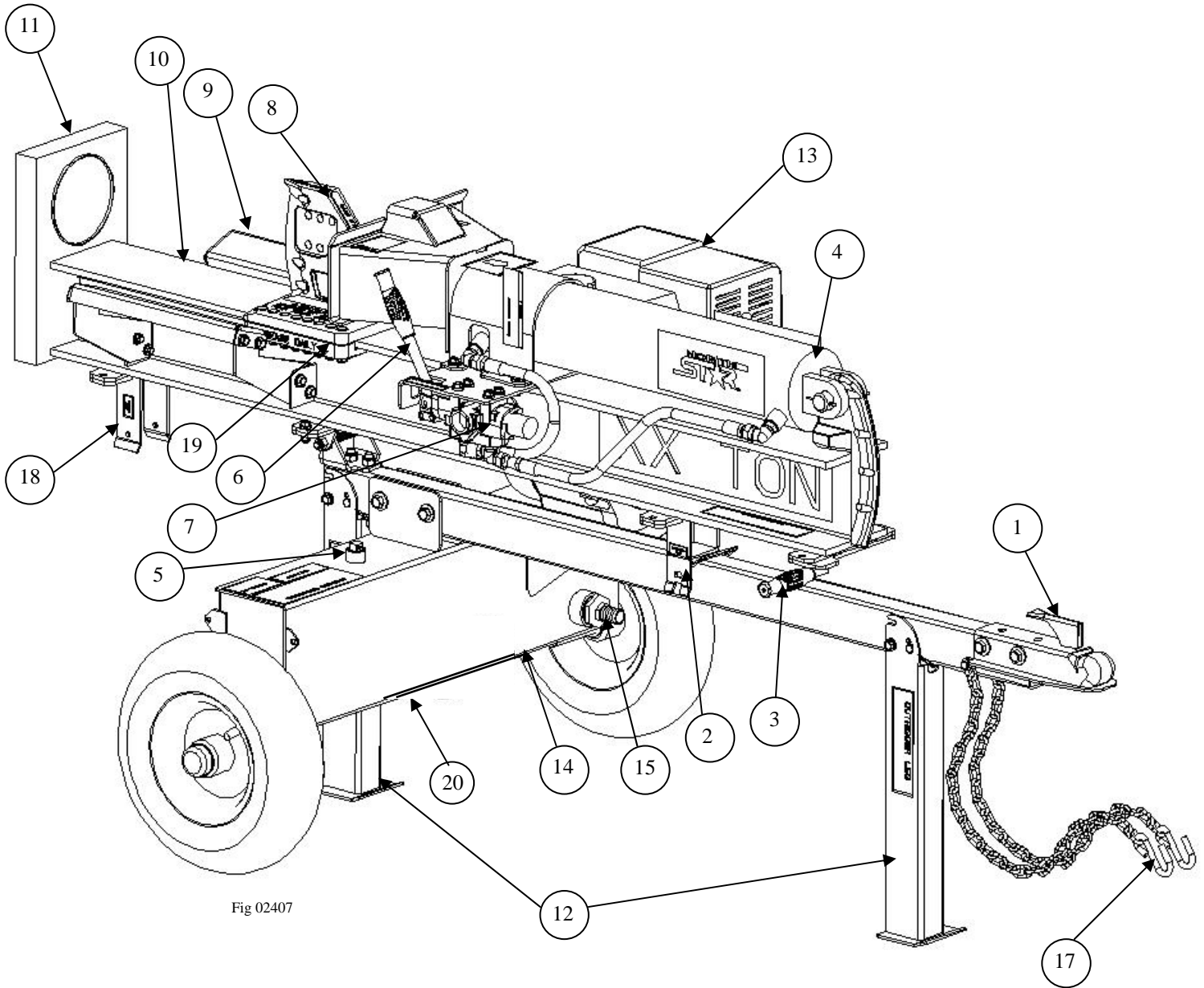

Fig 02407

Ref #	Description
1	2" Ball Coupler
2	Horizontal Lock
3	Lifting Handle
4	Cylinder
5	Hydraulic Oil Dipstick
6	Split Control Lever
7	Control Valve
8	Wedge
9	Log Cradle
10	Beam

Ref #	Description
11	Endplate
12	Outrigger Legs
13	Engine
14	Hydraulic Tank
15	Suction Strainer
17	Safety Chains
18	Vertical Lock
19	Grease Zerks
20	Drain Plug

Initial Set-Up

IMPORTANT!

Engine is shipped without oil. DO NOT start the engine before adding oil.

See Assembly Instructions section of this manual to assemble the log splitter before set-up.

<p><u>Step One:</u> Inspect Log Splitter Components.</p>	<p>Closely inspect all log splitter components. (See Machine Components section of this manual for diagram of components.)</p> <ul style="list-style-type: none"> • If you have missing components, contact Product Support at 1-800-270-0810. • If you have damaged components, contact the Freight Company that delivered the unit and file a claim.
<p><u>Step Two:</u> Add Oil to Engine</p>	<p>Add oil to the engine. Using a funnel. Add SAE 10W-30 oil up to the FULL mark on the dipstick. (See engine Owner's Manual for oil capacity and location of fill cap.)</p>
<p><u>Step Three:</u> Add Hydraulic Oil to Reservoir</p>	<p>⚠ WARNING: High fluid pressures and temperatures are developed in hydraulic log splitters. Hydraulic fluid escaping through a pin hole sized opening can burn or puncture skin, resulting in wounds that could cause blood poisoning, infection, disability, gangrene, amputation, or death. Therefore, the following instructions should be heeded at all times when inspecting or servicing the hydraulic components of the log splitter.</p> <ul style="list-style-type: none"> • NEVER check for leaks with your hand. Leaks can be located by holding a piece of cardboard or wood (at least two feet long) with your hand at one end and passing the other end over the suspected area (wear eye protection). Look for discoloration of the cardboard or wood. • NEVER adjust the pressure of the pump or valve. • If injured by escaping fluid, no matter how small the wound is, see a doctor at once. A typical injection injury may be a small wound that does not look serious. However, severe infection or reaction can result if proper medical treatment is not administered immediately by a doctor who is familiar with injection injuries. <ol style="list-style-type: none"> 1. Remove hydraulic oil dipstick. 2. Refer to the Specifications section for approximate hydraulic oil capacity. 3. Fill reservoir with 10 wt AW32, ASLE H-150, or ISO 32 oil. Use a funnel 4. Replace hydraulic oil dipstick. 5. Start engine and use control valve handle to extend and retract wedge 5 (five) times to remove air from the high pressure lines. 6. With wedge retracted, check oil level again. Fill if necessary. <p>⚠ WARNING: NEVER remove the hydraulic oil fill cap when the engine is running or hot. Hot oil can escape causing severe burns. Allow log splitter to cool completely before removing hydraulic oil fill cap.</p> <p>Note: If the log splitter will be run for long periods of time in outdoor temperatures above 70F, we recommend changing the hydraulic oil to DEXTRON III.</p>

Initial Set-Up

Step Four:
Lubricate Keepers

Pump grease into grease zerks found under each keeper. This will help prevent wear between the keepers and beam.

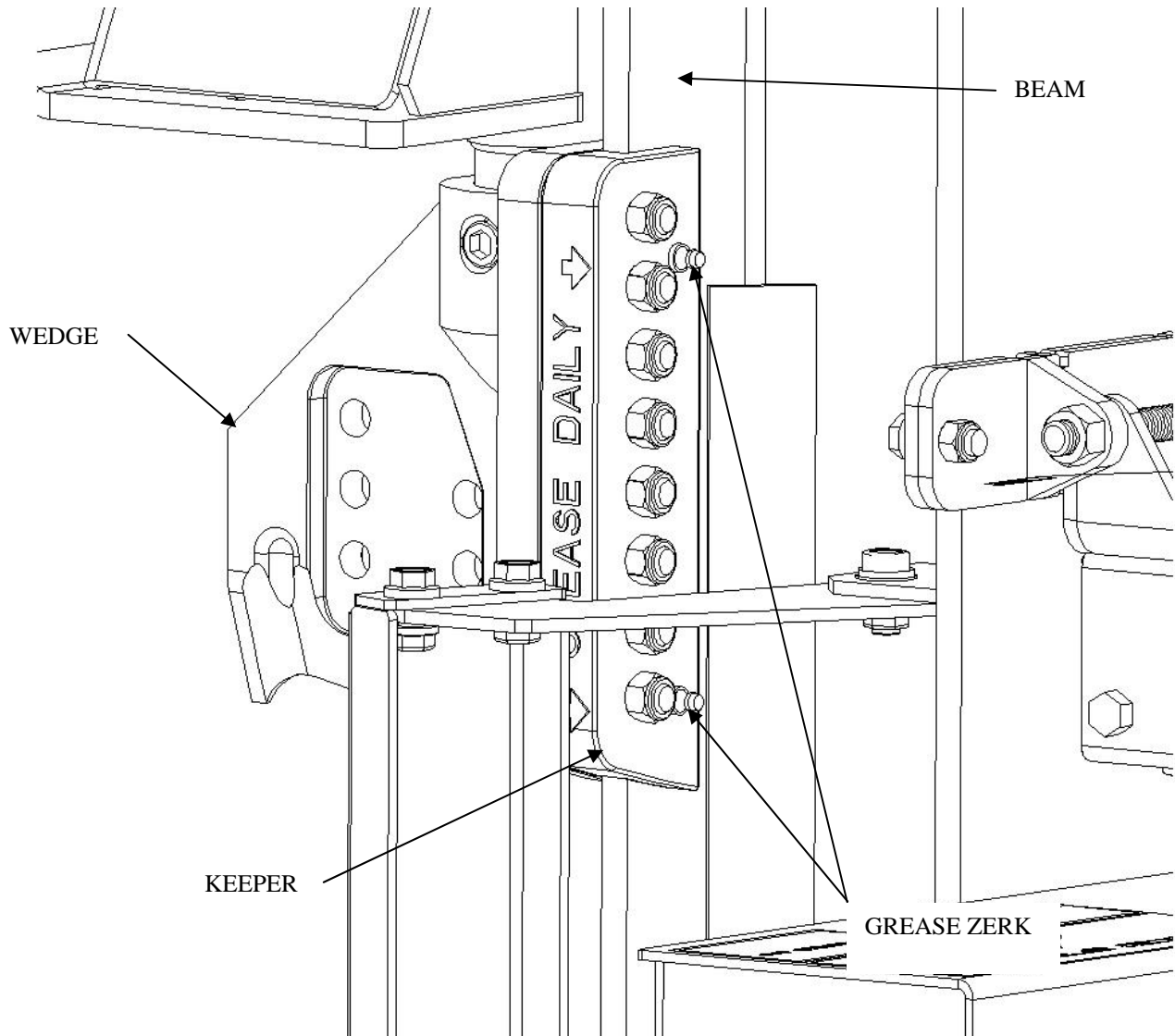

Optional 4-Way Wedge Wings

4-Way Wedge Wings

Wing Assembly

1. Unbox and identify components
2. Insert Nylon nuts into hex cutouts in wing
3. Position wings into proper locations on the wedge and bolt into position using supplied bolts
4. Tighten the bolts with a 3/8" hex wrench

Exploded View

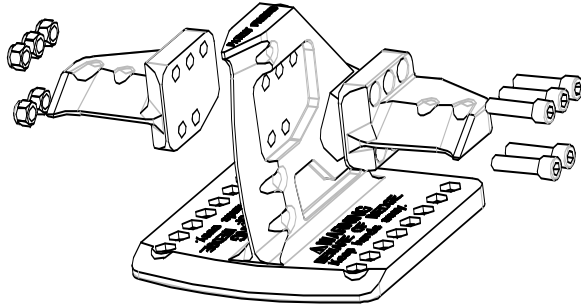

Assembled View

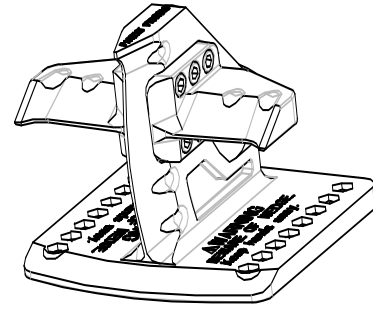

FIG02435

⚠ WARNING

- 4-Way Wings create additional pinch points when the wedge is moving forward or backwards. Keep hands clear of the wedge, wedge wings, and the log while the wedge is moving. When the log is caught on the wedge do not use the auto-return feature. Retract wedge manually, paying close attention so the log does not hit the engine or control valve.
- Pay particular attention to stringy wood, such as elm, because it becomes lodged on the wedge easily.

To order call: Northern Tool + Equipment at 1-800-556-7885
Item # 1143

Moving and Towing to the Job Site

WARNING

The log splitter is heavy. It can crush and cause serious injury if it rolls out of control or tips over.

Follow the instructions below for safely moving and towing the log splitter.

Moving the log splitter:

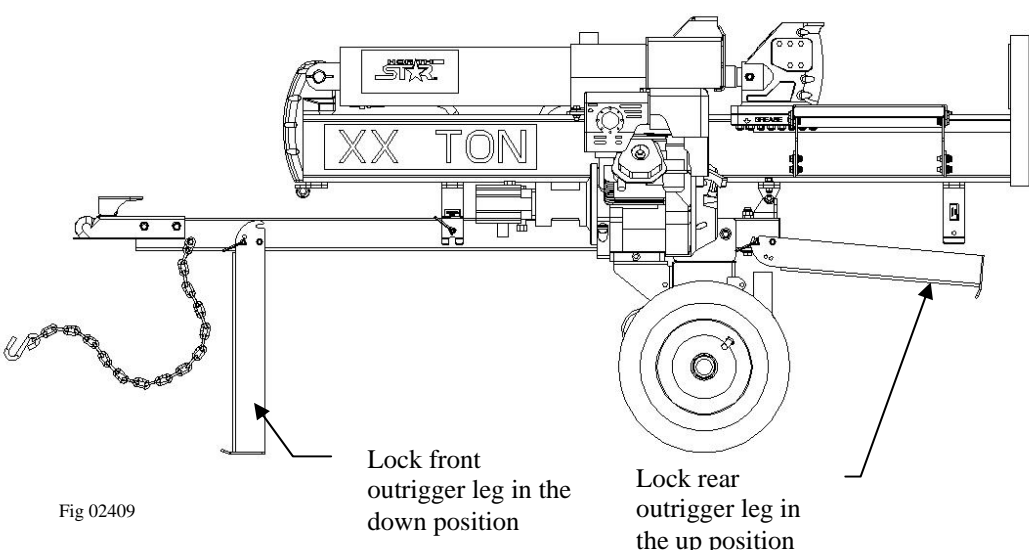
<p>1. Place in Horizontal position</p>	<p>Make sure the log splitter is locked in the horizontal position with hitch pin before moving.</p> <p>NEVER move log splitter when it is in vertical configuration because it will be unstable and could tip.</p>
<p>2. Engine off.</p>	<p>IMPORTANT: Make sure log splitter engine is off.</p> <p>Never move the log splitter with its engine running.</p>
<p>3. Fuel valve off (if equipped)</p>	<p>Turn fuel valve off to prevent carburetor flooding and reduce the chance of fuel leakage. Refer to Engine owner's manual for fuel valve location.</p>
<p>4. Lock:</p> <ul style="list-style-type: none"> • Front <u>outrigger leg</u> DOWN • Rear <u>outrigger leg</u> UP 	<p>Lock the front <u>outrigger leg</u> in the “DOWN” position and the rear <u>support leg</u> in the “UP” position before you move the log splitter.</p>  <p>Fig 02409</p> <p>Lock front outrigger leg in the down position</p> <p>Lock rear outrigger leg in the up position</p>
<p>5. Move log splitter to work site or tow hitch</p>	<p>Move log splitter by hand either directly to chosen work site or to vehicle hitch for towing.</p> <p>(See Before Each Use: Step Three: instructions on selecting a work site)</p> <p><u>Important Safety Instructions:</u></p> <ul style="list-style-type: none"> • Hills. Do not move the log splitter up or down hills by hand—use a towing vehicle. • No riding. Never allow anyone to sit or ride on the log splitter. • No cargo. Never transport cargo or wood on the log splitter.

Moving and Towing to the Job Site

Towing:

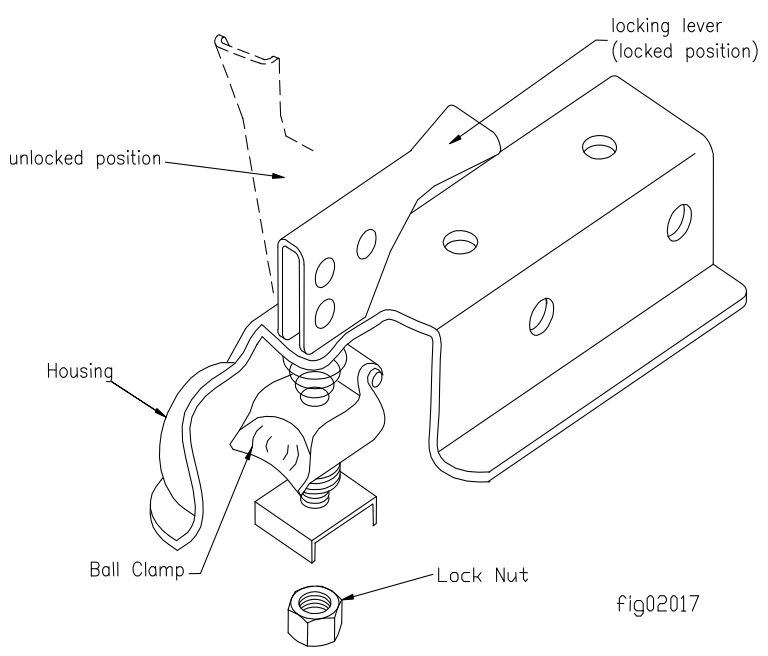
<p>1. Read instructions</p>	<p>Review towing safety instructions in your vehicle manual.</p>
<p>2. Check tires</p>	<p>Make sure tires are fully inflated and in good repair.</p> <p>⚠️WARNING:</p> <ul style="list-style-type: none"> • Do not over-inflate tires. Serious injury can occur if tire explodes. • When seating a bead after repair, do not exceed 30 PSI. Pressures higher than 30 PSI can cause the tire and wheel to rupture and explode.
<p>3. Attach to hitch (2" ball)</p>	<p>Attach log splitter to vehicle hitch</p> <ol style="list-style-type: none"> 1. Attach log splitter's coupler to a class 2 or higher hitch with 2" ball (only). 2. Adjust coupler to ball by raising locking lever and turning lock nut with fingers. 3. Proper adjustment is obtained when coupler is as tight as possible on ball and locking lever can still be opened and closed. 4. Lock lever closed to secure the attachment. An optional locking pin or padlock may be inserted in the locking lever hole for extra security. 
<p>4. Attach safety chains</p>	<p>Attach safety chains.</p> <ol style="list-style-type: none"> 1. Two safety chains must be used while towing. 2. Cross safety chains under the coupler allowing only enough slack for vehicle turns.

Moving and Towing to the Job Site

5. Put front outrigger leg UP

Move the **front outrigger leg** to the “UP” position and lock. (Both outrigger legs must remain in the up position during towing.)

Fig 02410

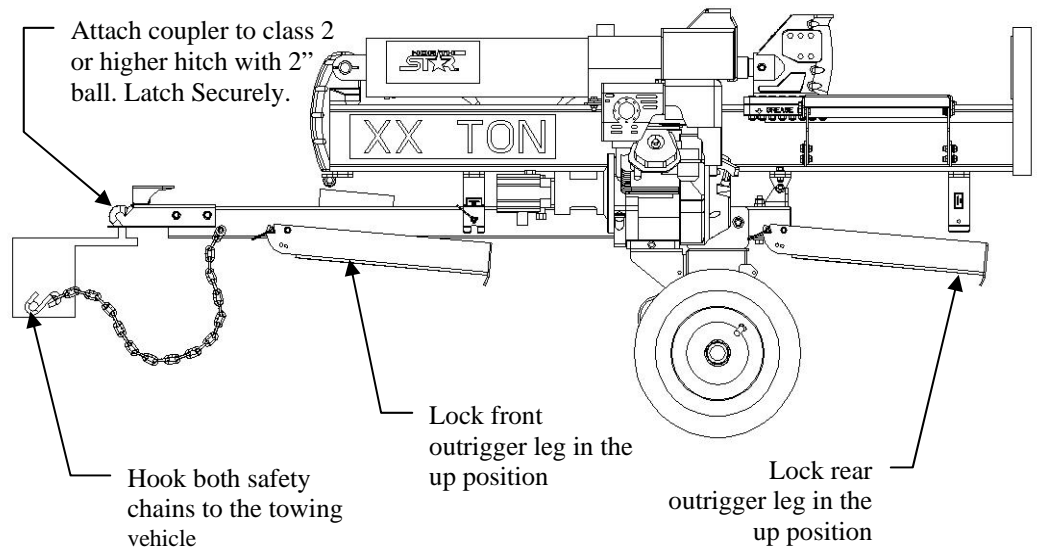

6. Tow to desired location

Tow log splitter carefully to desired work site.
(See Before Each Use section on selecting an appropriate work site)

Important safety instructions:

- **Added length.** Be aware of the added length of the splitter.
- **Speed limit.** Never tow this log splitter over 45 mph. Faster speeds may result in loss of control.
- **Rough terrain.** Drive slowly and take extra caution when traveling over rough terrain.
- **On public roads.** If towing on a public road, make sure to comply with all local, state, and federal towing requirements. It is the sole responsibility of the purchaser to obtain licensing, trailer lights, safety chains or signage, as needed to comply.
- **Unattended.** Turn off the towing vehicle before leaving the splitter unattended.
- **Under the influence.** Never tow or operate this splitter while under the influence of alcohol, drugs, or medication.

7. Lock front outrigger leg down & unhitch

Lock front outrigger leg in the DOWN position and disconnect from vehicle.
NEVER operate log splitter while it is attached to the vehicle.

Before Each Use-Inspection / Maintenance

Step One: Inspect and maintain log splitter before each use

If the log splitter has been used previously, it must be inspected and maintained BEFORE EACH SUBSEQUENT USE.

⚠ WARNING

ALWAYS shut off the engine, disconnect the spark plug, and relieve system pressure before inspecting, cleaning, adjusting, or repairing the splitter. Relieve system pressure by moving Split Control Lever back and forth several times.

IMPORTANT:

If a part needs replacement, only use parts that meet the manufacturer's specifications. Replacement parts that do not meet specifications may result in a safety hazard or poor operation of the log splitter.

1. Engine off / relieve pressure	<p>Perform all inspections/repairs with the engine off and hydraulic system pressure relieved.</p> <ol style="list-style-type: none"> 1. Make sure engine is off and cool. 2. Disconnect the spark plug 3. Relieve all hydraulic system pressure by moving the Split Control Lever back and forth several times.
2. Remove debris	<p>Remove debris from engine, muffler, and moving parts.</p> <ol style="list-style-type: none"> 1. <u>Engine debris.</u> Debris on a hot engine can be a fire hazard. Clean debris and chaff from engine cylinder head, cylinder head fins, blower housing rotating screen, and muffler areas. Avoid contact with hot muffler. 2. <u>Other debris.</u> Debris on moving parts can cause excess wear. Clear debris from the slide beam, wedge, and endplate.
3. Fuel tank / lines	<p>Check fuel tank and fuel lines for leaks.</p> <p>Any fuel leak is a fire hazard. Fix any fuel leaks before starting engine.</p>

4. Mechanical parts **Check to be sure that all nuts and bolts are tight** to make sure the log splitter is in safe working condition.

Apply grease to grease zerks.

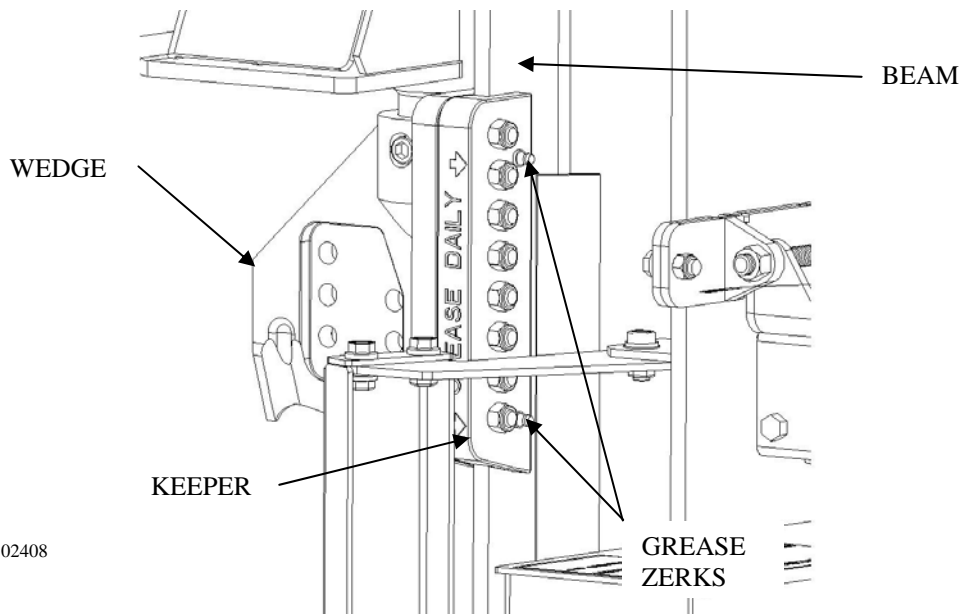

Fig 02408

Before Each Use-Inspection / Maintenance

5. Hydraulic system	<p>Check the hydraulic system carefully:</p> <ol style="list-style-type: none"> 1. Visually inspect all hoses, tubing, clamps/fittings, pump, and cylinder for cracks, fraying, kinks, or other damage. 2. Check all components for oily residue, which may indicate a leak. <p>Do NOT operate the log splitter if there is any indication of damage or oily residue. Small leaks in hydraulic lines can cause severe injuries and can also be an indication of catastrophic failure in the near future. The life of hydraulic hoses may be from a few months to a few years, depending on use and storage patterns.</p> <p>⚠ WARNING: High fluid pressures and temperatures are developed in hydraulic log splitters. Hydraulic fluid escaping through a pin hole sized opening can burn or puncture skin, resulting in wounds that could cause blood poisoning, infection, disability, gangrene, amputation, or death. Therefore, the following instructions should be heeded at all times when inspecting or servicing the hydraulic components of the log splitter:</p> <ul style="list-style-type: none"> • Stop the engine, disconnect the spark plug, and move all control valve handles back and forth to relieve pressure before changing or adjusting hydraulic system components such as hoses, tubing, fittings or other components. • NEVER check for leaks with your hand. Leaks can be located by holding a piece of cardboard or wood (at least two feet long) with your hand at one end and passing the other end over the suspected area (wear eye protection). Look for discoloration of the cardboard or wood. • NEVER adjust the pressure setting of the pump or valve. • If injured by escaping fluid, no matter how small the wound is, see a doctor at once. A typical injection injury may be a small puncture wound that does not look serious. However, severe infection or reaction can result if proper medical treatment is not administered immediately by a doctor who is familiar with injection injuries.
6. Hydraulic oil level	<p>Check the hydraulic oil level using the dipstick. Fill as needed.</p> <p>⚠ WARNING: NEVER remove the hydraulic oil dipstick when the engine is running or hot. Hot oil can escape causing severe burns. Allow log splitter to cool completely before removing hydraulic oil dipstick.</p>
7. Engine	<p>Inspect and perform engine maintenance as directed in the engine manual.</p>
8. Spark arrestor muffler	<p>If the engine is equipped with a spark arrestor muffler, clean and inspect it regularly (follow spark arrestor manufacturer's service instructions).</p> <p>Replace if damaged.</p>
9. Tires	<p>Make sure tires are fully inflated and in good repair if you will be towing the splitter.</p> <p>See tire sidewall for recommended tire pressure.</p> <p>⚠ WARNING:</p> <ul style="list-style-type: none"> • Do not over-inflate tires. Serious injury can occur if tire explodes. • When seating a bead after repair, do not exceed 30 PSI. Pressures higher than 30 PSI can cause the tire and wheel to rupture and explode.
10. Shields / guards	<p>Replace all guards and shields after servicing the log splitter.</p>



Before Each Use - Fueling

Step Two: Fueling



WARNING

Gasoline is highly flammable and explosive. You can be burned or seriously injured when handling fuel. Use extreme care when handling gasoline.

1. Engine off / cool	<p>The engine must be off and allowed to cool at least two minutes before adding fuel.</p> <p> WARNING: A running engine is hot enough to ignite fuel. Never add fuel or remove gas cap if engine is running or still hot.</p>
2. Outdoor location	<p>Fill fuel tank outdoors – never indoors.</p> <p> WARNING: Gasoline vapors can ignite if they collect inside an enclosure. Explosion can result.</p>
3. Remove gas cap	<p>Remove engine gas cap.</p>
4. Add gasoline	<p>Add gasoline through fill opening from a UL-approved container.</p> <p><u>Important Safety Instructions:</u></p> <ul style="list-style-type: none"> • Use approved container. NEVER pump fuel directly into engine at gas station. Static charge can build and ignite fuel. Use a UL approved fuel container to transfer gas to the engine. • Don't overfill. DO NOT overfill the gas tank. Allow at least 1/2" of empty space below the fill neck to allow for fuel expansion • Heat / flames / sparks. Stay away from sources of heat, flame, or sparks while adding fuel.
5. Spills / splashes	<p>Clean up fuel spills /splashes immediately.</p> <ol style="list-style-type: none"> 1. Move the log splitter away from spilled fuel on the ground. 2. Wipe fuel off engine and wait 5 minutes for excess fuel to evaporate before starting engine. 3. Gas soaked rags are flammable and should be disposed of properly. 4. If gasoline is spilled on your skin or clothes, change clothes and wash skin immediately.
6. Replace gas cap	<p>Replace gas cap securely before starting engine.</p>
7. Gasoline storage	<p>Store extra gasoline in a cool, dry place in a UL approved, tightly sealed container.</p>

Splitting Operation

Step Three: Work site selection and log splitter set-up

⚠ WARNING

It is important to select an appropriate work site and properly set up the log splitter in order to minimize the risk of slips and falls, equipment rolling or tipping over, carbon monoxide poisoning, and accidental fires.

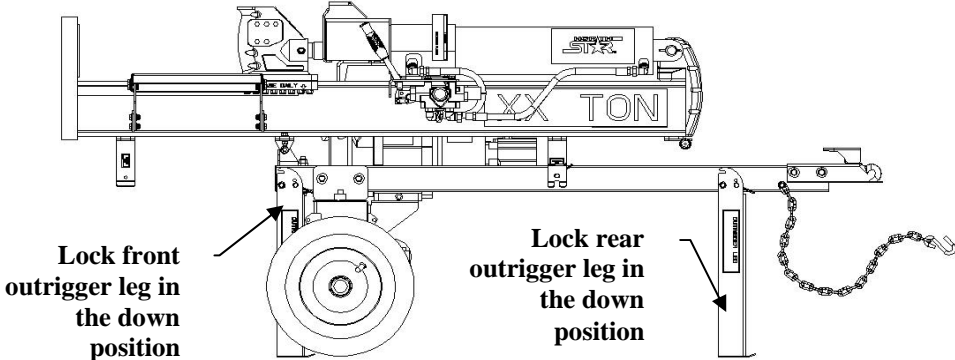
<p>1. Select location</p>	<p>Select an appropriate location for operating the log splitter.</p> <p><u>Requirements:</u></p> <ol style="list-style-type: none"> 1. Dry-level surface with good footing. Stay clear of areas with mud, ice, tall grass, weeds, brush, or snow. 2. Outdoors, away from air intakes. <p>⚠ WARNING: The running engine gives off carbon monoxide, a poisonous gas that can kill you. You CANNOT smell it, see it, or taste it.</p> <ul style="list-style-type: none"> • ONLY run log splitter <u>OUTDOORS</u> and away from air intakes. NEVER run log splitter inside homes, garages, sheds, or other buildings or semi-enclosed spaces. These spaces can trap poisonous gases, EVEN if you run a fan or open windows. • If you start to feel sick, dizzy, or weak while using the log splitter, shut off the engine and get to fresh air <u>RIGHT AWAY</u>. See a doctor. You may have carbon monoxide poisoning.
<p>2. Fire precautions</p>	<p>Take the following precautions against fire:</p> <ol style="list-style-type: none"> 1. <u>IMPORTANT:</u> If your splitter will be used near any unimproved forest, brush, or grassy covered land, then engine must be equipped with a <u>spark arrestor</u>. <p>(See the “Specifications” section of this manual to determine if your splitter already has a spark arrestor. Contact NorthStar Product Support at 1-800-270-0810 for information about obtaining a spark arrestor for your log splitter if it is unequipped.)</p> <ol style="list-style-type: none"> 2. Make sure you comply with applicable local, state and federal codes. 3. Keep a fire extinguisher available (classified for both ordinary combustibles & flammable liquids) as a precautionary measure when operating the log splitter in dry areas.
<p>3. Position splitter 7' from any combustibles or flammable liquids</p> <p>4. Lock both outrigger legs DOWN</p>	<p>Position muffler at least 7 ft. from combustible objects during operation. Hot exhaust fumes from engine could cause fire. Also, hydraulic oil leaking or spraying on hot engine can ignite.</p> <p>Lock both the <u>outrigger legs</u> in the “DOWN” position.</p> <div style="text-align: center;">  </div>
<p>5. Block wheels</p>	<p>Block the wheels to prevent unintended movement of the log splitter.</p>
<p>6. Apply grease</p>	<p>Apply grease into grease zerks located under both keepers.</p>

Splitting Operation

WARNING

Before starting this log splitter, review the following instructions and safety information for safe operation of the log splitter.

Failure to follow these rules may result in serious injury to the operator or bystanders from moving parts that crush, cut, or entangle from flying objects, burns, fire, falling or tripping, or from carbon monoxide poisoning.

General safety information:

- **Read manual.** Do not allow anyone to operate the log splitter who has not read the Owner's Manual or has not been instructed on the safe use of the splitter. The log splitter owner should instruct all operators in safe log splitter operation.
- **Age restrictions.** Never allow anyone under 16 years old to operate the log splitter. Anyone 16 years and older must be trained and supervised by a trained adult.
- **Intended use.** Log splitters should only be used for splitting wood logs, lengthwise with the grain. Do not use for other purposes as unforeseen hazards may result.
- **Modifications.** Never modify or alter the log splitter in any way. Modifications can create serious safety hazards and will void the warranty:
- **Attachments.** Never add attachments to the splitter, except for authorized accessories supplied by the manufacturer with instructions for safe installation and use.
- **Engine speed.** The maximum engine speed is preset at a safe limit. Never attempt to modify the engine speed setting to run at a higher speed.
- **Fuel/exhaust system.** NEVER modify or add to the exhaust system, fuel tanks, or fuel lines. Fire can result.
- **Remote control.** NEVER attach a rope, cable, or other remote device to the splitting control.
- **Splitting wedge.** NEVER attempt to change the height or speed of the splitting wedge.
- **Pressure setting.** NEVER increase the pressure setting of the pump or control valve.
- **Safety equipment / controls.** Always operate the log splitter with all safety equipment in place and in good working order, and all controls properly adjusted for safe operation.
- **Know how to stop.** Be thoroughly familiar with all controls and with the proper use of the equipment. Know how to stop the log splitter and relieve system pressures quickly if needed.
- **Operating speed.** Always operate the log splitter at the manufacturer's recommended speed. The maximum speed of the engine pump and wedge are preset within safe limits.
- **Daylight only.** Only use the log splitter in daylight so you can see what you are doing.
- **Smoking / sparks.** Never smoke while operating the log splitter, and never operate near sources of sparks or flames.
- **Under the influence.** Never operate, or let anyone else operate, the log splitter while under the influence of alcohol, drugs, or medication.
- **Unattended.** Never leave the machine unattended while the engine is running.
- **Refueling.** Never refuel the engine until it has cooled at least two minutes.
- **Adjusting / repairing.** Always make sure the engine is off before cleaning, repairing or adjusting the splitter, except as recommended by the manufacturer. In addition, disconnect the spark plug and move all control handles back and forth to relieve system pressure *before changing or adjusting hydraulic system components* such as hoses, tubing, fittings or other components.
- **Replace labels.** Always make sure safety labels are in place and in good condition. If a safety label is missing or not legible, order new labels because unsafe operation can result. Call 1-800-270-0810 to order new safety labels.

Splitting Operation

1. Put on protective clothing / gear

Wear the following protective clothing and safety gear:

- 1) **Eye protection.** Always wear safety glasses or goggles when operating the machine. Pieces of log may fly out and serious eye injury can occur.
- 2) **Boots.** Falling logs can crush feet. Always wear safety shoes or heavy boots when operating or helping to load logs.
- 3) **Gloves.** Wear snug fitting gloves without drawstrings or loose cuffs.
- 4) **Hearing protection.** The use of earplugs or other hearing protection device is recommended.
- 5) **No Loose / dangling.** Loose or dangling apparel can become entangled in moving parts. Never wear jewelry or loose-fitting clothing.

2. Lock & block

Block the wheels to prevent unintended movement of the log splitter. Check that:

- 1) The outrigger legs are both locked in the DOWN position.
- 2) The wheels are blocked.

3. Set to horizontal or vertical:

Set log splitter into either the horizontal or vertical splitting position

The HORIZONTAL splitting position is used for lighter logs that can be easily loaded onto the beam. The VERTICAL splitting position is used for light logs as well as heavy logs that are difficult to load onto the beam.

Note:

Musculoskeletal injury can result from lifting logs onto the log splitter if proper lifting techniques are not used or the logs are too heavy for a person's size, weight, or strength. In some cases, logs as small as 8" in diameter and 14" in length may be heavier than what some persons should be repeatedly lifting onto the splitter.

The use of the vertical splitting position can greatly reduce the need to lift logs onto the splitter. Employers are advised to consider NIOSH lifting guidelines when assigning employees to log splitting tasks for an extended period of time.

⚠ WARNING: NEVER change splitting positions with the engine running. You may contact the muffler and receive serious burns.

a) Set to Horizontal position

Make sure beam is locked securely in the horizontal position by checking the horizontal lock. Rear outrigger leg must be locked in horizontal splitting position.

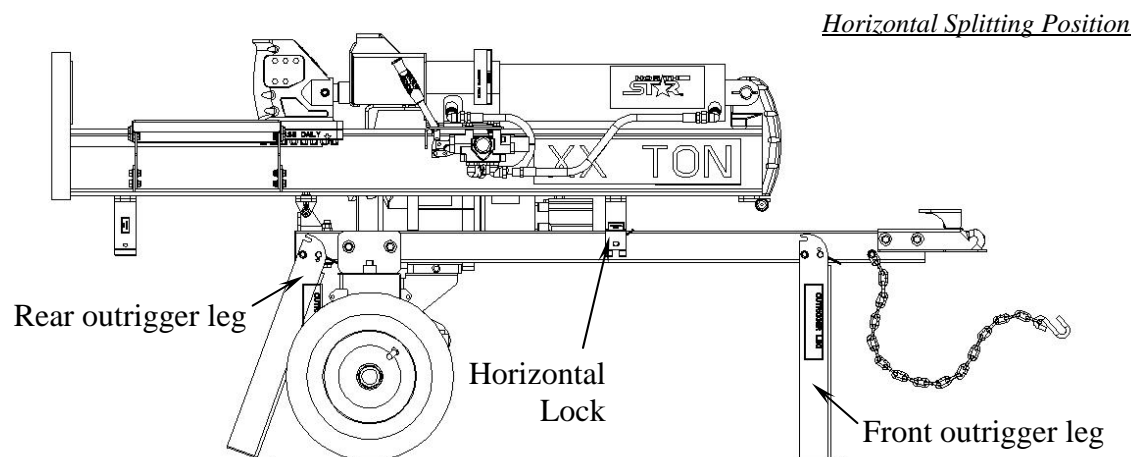

Fig 02412

Splitting Operation

b) Set to
Vertical
position

- 1) Lock rear outrigger leg in down position.
- 2) Pull out horizontal lock catch pin, grasp lifting handle and lift beam until it rotates into vertical position.

⚠️ WARNING: Crush hazard. The beam is heavy – do not let it just drop. It could crush fingers or cause damage to the splitter.

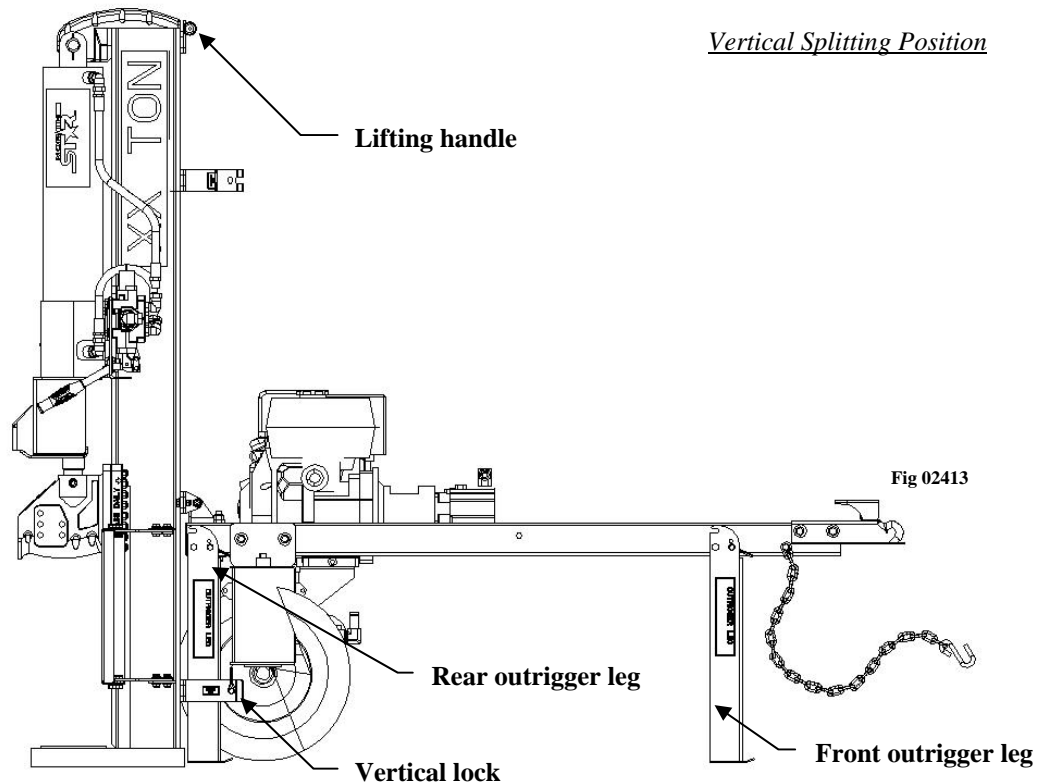

- 3) Lock in vertical position using catch pin through the vertical lock.
- 4) To return to horizontal position, unlock vertical position, grasp lifting handle and lower beam carefully in a controlled manner until it rests on the tow bar, lock beam in the horizontal position with catch pin.

4. Start engine

Start the engine.

See the engine owner's manual for engine starting instructions.

NOTE:

- a) Make sure the hydraulic oil is above 10°F before starting the engine. Cold hydraulic oil can damage the hydraulic pump.
- b) If outdoor air temperature is below 32°F, allow log splitter to warm up by extending and returning the wedge several times before splitting wood.

⚠️ WARNING:

Burns. To avoid burns, stay clear of hot muffler if you are starting a warm engine.

Carbon monoxide. The running engine gives off carbon monoxide, a poisonous gas that can kill you. You CANNOT smell it, see it, or taste it. If you start to feel sick, dizzy, or weak while using the log splitter, shut off the engine and get to fresh air RIGHT AWAY. See a doctor. You may have carbon monoxide poisoning.

Other exhaust dangers. Engine exhaust, some of its constituents, and certain vehicle components contain or emit chemicals known to the State of California to cause cancer, birth defects, or other reproductive harm. Avoid inhalation of exhaust.

Splitting Operation

5. Load log

Load log onto beam with a cut end against the endplate – positioned for a lengthwise cut.

Notes:

- The log splitter is designed only for cutting lengthwise with the grain, NOT for cutting across the grain.
- This log splitter is designed for cutting logs only up to a maximum of 16" in diameter and 25" long. Larger diameter logs could get stuck on the wedge and longer logs will not fit on the beam.

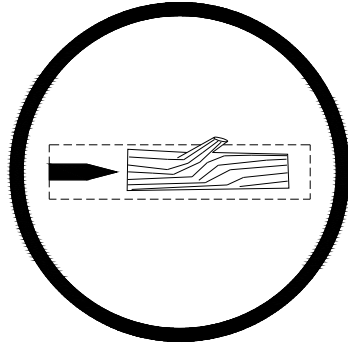

Correct Log Orientation

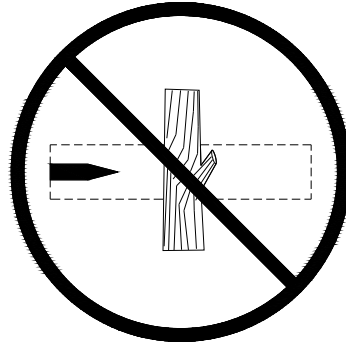

Incorrect Log Orientation

⚠ WARNING: ALWAYS keep hands and feet away from the endplate, wedge, and partially split logs while loading, operating and unloading the log splitter.

Important safety instructions:

- **Hold bark side.** Hold the bark side of logs when loading or positioning, never the ends. Never place your hands or any part of your body between a log and any part of the log splitter.
- **NOTE for vertical position loading:** Place the log on the endplate and turn it until it leans against the beam and is stable. If the log is too big or oddly shaped, stabilize the log with wooden shims between the log and endplate or ground. **DO NOT** use your leg or knee to stabilize the log. **NEVER** stabilize the log by placing your hand on top of the log.
- **Wedge moving.** NEVER load or unload logs while the wedge is moving.
- **Straddling / reaching across.** Never straddle, reach across, or step over the beam while the engine is running and the log splitter is in the horizontal position. You could trip, actuate the controls, and get seriously injured.
- **Unsplit log pile.** Do not pile logs to be split in a place that will make you reach across the log splitter in order to load them.
- **Square log ends.** Logs that are not cut square can slide out while splitting and become a safety hazard or cause excessive force to log splitter components. Use a chainsaw to cut logs square on each end before attempting to split them.
- **Single log.** Never attempt to split more than one log at a time. Pieces of log can unexpectedly be thrown from the machine causing serious injury.
- **Split along grain.** Do not use the log splitter to split logs across the grain. Doing so will damage the log splitter and could also cause pieces of log to be thrown, injuring the operator or bystanders.
- **Changing splitting position.** Do not change splitting positions (horizontal/vertical) with the engine running. You may contact the muffler and receive serious burns. Be careful to avoid contact with hot muffler even after the engine is turned off.

Splitting Operation

6. Extend wedge

Move Split Control Lever toward endplate to extend wedge and split log.

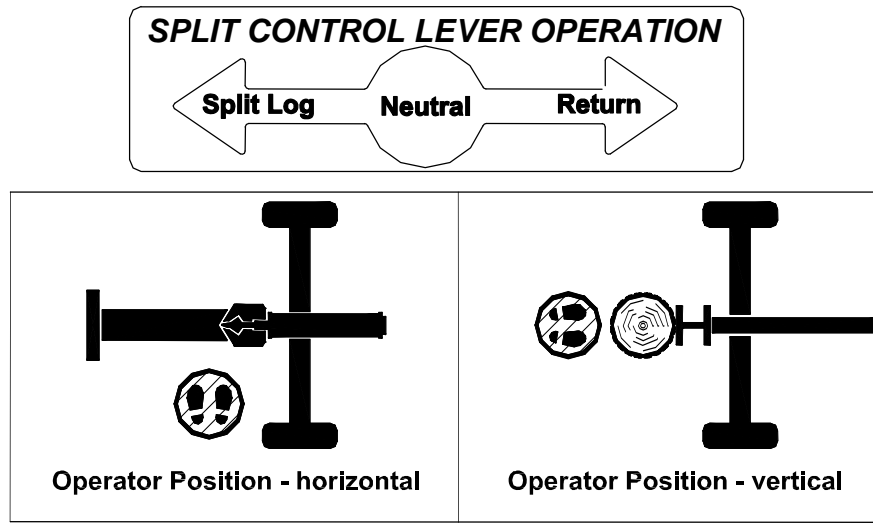

Important safety instructions:

- **Operator position.** ALWAYS operate the log splitter from the manufacturer’s indicated OPERATOR POSITION. (See diagram above.) Other positions are unsafe because they can increase the risk of injury from crushing, cutting, flying objects, or burns.
- **Remove hands.** Remove both hands from log before activating Split Control Lever.
- **Hand activate.** Use only your hand to operate the Split Control Lever. Never use any other body part, or a rope, cable, or other remote device to actuate the control.
- **Second person.** Many accidents occur when there is more than one person involved in loading and operating the log splitter. Only one person should operate the controls. *If a second person is assisting in loading logs, the operator must NEVER actuate the Split Control Lever until the assistant and all bystanders are at least 10 feet away. NEVER allow an assistant to hold the log in place while the operator actuates the Split Control Lever.*

7. Stop wedge

Release Split Control Lever to stop wedge movement when log is split.

⚠ WARNING: Cracks in logs can close quickly and pinch fingers. Keep fingers away from any cracks that open in partially split logs.

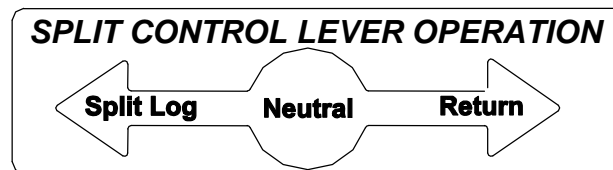

8. Important STUCK LOG procedure

If a log does not split completely and becomes stuck on the wedge, follow the instructions below to remove the log.
 A log can become stuck to the wedge if the wedge becomes embedded in the log and the log doesn’t split and separate. This can happen if the log is too stringy or tough to split completely. A stuck log will move back with the wedge on the initial attempt to retract the wedge. If this happens, retract the wedge completely to allow the splitter to strip the log from the wedge. Keep hands clear of log and wedge while wedge is retracting.

Splitting Operation

- ⚠ WARNING: NEVER** attempt to remove a stuck log by:
- Modifying the splitter.
 - Adding attachments to the splitter.

Personal injury could result from log or metal pieces flying out at high speed toward the operator or bystanders, or the splitter could become damaged.

9. Return wedge

Move Split Control Lever away from end plate to return wedge.

Once the control valve is actuated in the return direction, the wedge is designed to keep returning by itself completely and then stop automatically.

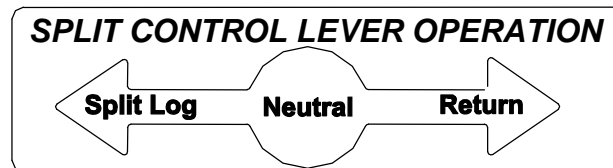

⚠ WARNING:

Stay clear while the wedge is returning. It is still powerful enough on the return stroke to cause serious injury.

10. Remove split wood

Remove split wood from area.

Move each log away from log splitter after it is split. Split logs left near the log splitter are a trip hazard.

11. After use

1. Turn off engine.

2. Remove engine debris.

Debris on a hot engine can be a fire hazard. After the engine is off, clean debris and chaff from engine cylinder head, cylinder head fins, blower housing rotating screen, and muffler areas.

⚠ WARNING: Avoid contact with hot muffler.

3. Return to horizontal position.



If in the vertical position, return log splitter to the horizontal position for greater stability and to prepare for transportation. Avoid contact with hot muffler.

Storage

WARNING

Gasoline vapors can ignite and cause a fire. Select a well-ventilated storage away from sources of heat, flame, or sparks.

Follow the instructions below for storing your log splitter between uses.

1. Retract wedge	Retract the wedge completely to keep the rod protected from corrosion.
2. Cool	Allow the machine to cool 5 minutes before storing.  WARNING: A hot engine can be a fire hazard.
3. Wipe with oily rag	Wipe the beam and wedge with an oily rag to prevent corrosion.
4. Engine manual	<p>Refer to the engine manual for proper engine storage instructions.</p> <p>CAUTION: Gasoline will oxidize and deteriorate in storage. Old gasoline in the engine will cause hard starting and leave gum deposits that can clog the fuel systems. Deterioration problems may occur within a few months, or even less if gasoline was not fresh when you filled the tank.</p> <p><u>Short-Term Storage:</u></p> <ol style="list-style-type: none"> 1. Consider adding a fuel stabilizer to extend fuel storage life. 2. Leave the fuel valve lever in the OFF position to reduce the possibility of fuel leakage. <p><u>Long-Term Storage:</u> (between infrequent uses and at end of season) Drain the fuel tank and carburetor as instructed in the engine owner’s manual.</p> <p><u>Important Safety Instructions</u></p> <ul style="list-style-type: none"> • Always drain fuel from tank in outdoor, well-ventilated area. • Stay away from sources of heat, flame, or sparks while handling fuel. • Clean up fuel spills/splashes immediately.
5. Splitter storage location	<p>Store the log splitter in a location away from corrosive material, sources of heat, open flames, sparks or pilot lights.</p> <p> WARNING: Never store log splitter inside where there is a source of heat or an open flame, spark or pilot light – such as water heaters, space heaters, furnaces, clothes dryers, or other gas appliances – EVEN IF the log splitter’s gas tank is empty, residual gasoline vapors could ignite.</p> <p><u>NOTE:</u> Do not store the log splitter near fertilizer or any other corrosive material.</p>
6. Gasoline storage	<p>Store gasoline in a cool, dry place in an UL approved tightly sealed container.</p> <p> WARNING: Gasoline vapors can ignite if they collect inside an enclosure and explosion can result.</p>

Periodic Maintenance



In addition to the maintenance performed with each use, periodic maintenance should also be performed according to the following schedule.

 **WARNING**

ALWAYS shut off the engine, disconnect the spark plug, and relieve system pressure before cleaning, adjusting, or repairing the splitter. Relieve system pressure by moving Split Control Lever back and forth several times.

IMPORTANT:

If a part needs replacement only use parts that meets the manufacturer’s specifications. Replacement parts that do not meet specifications may result in a safety hazard or poor operation of the log splitter.

1. Engine maintenance	Perform engine maintenance as specified in engine owner’s manual.
2. Hydraulic Oil Change	<p>Change Hydraulic Oil Annually or Every 100 Hours.</p> <p> WARNING: High fluid pressures and temperatures are developed in hydraulic log splitters. Hydraulic fluid escaping through a pin hole sized opening can burn or puncture skin, resulting in wounds that could cause blood poisoning, infection, disability, gangrene, amputation, or death. Therefore, the following instructions should be heeded at all times when inspecting or servicing the hydraulic components of the log splitter.</p> <ul style="list-style-type: none"> • NEVER check for leaks with your hand. Leaks can be located by holding a piece of cardboard or wood (at least two feet long) with your hand at one end and passing the other end over the suspected area (wear eye protection). Look for discoloration of the cardboard or wood. • NEVER adjust the pressure of the pump or valve. • If injured by escaping fluid, no matter how small the wound is, see a doctor at once. A typical injection injury may be a small wound that does not look serious. However, severe infection or reaction can result if proper medical treatment is not administered immediately by a doctor who is familiar with injection injuries. <ol style="list-style-type: none"> 1. Use 10wt AW32, ASLE H-150, or ISO32 oil. 2. Relieve hydraulic system pressure by moving Split Control Lever back and forth several times. 3. Remove hydraulic oil dipstick. <p> WARNING: NEVER remove the hydraulic oil dipstick when the engine is running or hot. Hot oil can escape causing severe burns. Allow the log splitter to cool completely before removing hydraulic oil dipstick.</p> <ol style="list-style-type: none"> 4. Remove the drain plug from the hydraulic tank to drain the hydraulic oil into a 10 gallon pan. 5. Remove suction strainer and wipe off debris with a dry cloth. 6. Fill the hydraulic tank with wedge retracted. 7. Dispose of used oil at an oil-recycling center. Used hydraulic oil is hazardous waste. 8. Extend and retract wedge 5 (five) times to purge air from the system. 9. Check hydraulic oil level and fill if necessary.
3. Spark arrestor muffler	If the engine is equipped with a spark arrestor muffler, clean and inspect it regularly (follow manufacturer’s service instructions). Replace if damaged.

Troubleshooting

WARNING

Before troubleshooting or attempting to service, read the following safety instructions to avoid serious injury to the operator or bystanders from moving parts that can crush or cut, burns, fire or explosion, or escaping high pressure hydraulic fluid.

Important Safety Instructions:

1. **Engine off.** Always make sure the engine is off before cleaning, repairing or adjusting the splitter, except as recommended by the manufacturer.
2. **Hydraulic safety.** High fluid pressures and temperatures are developed in the hydraulic log splitters. Hydraulic fluid escaping through a pin hole sized opening can burn or puncture skin, resulting in wounds that could cause blood poisoning, infection, disability, gangrene, amputation, or death. Therefore, the following instructions should be heeded at all times when inspecting or servicing the hydraulic components of the log splitter:
 - Stop the engine, disconnect the spark plug, and move all control valve handles back and forth to relieve pressure before changing or adjusting hydraulic components such as hoses, tubing, fittings, or other components.
 - Do not remove the hydraulic oil fill cap when the engine is running. Hot oil can escape causing severe burns. Allow the log splitter to cool completely before removing the hydraulic oil fill cap.
 - Do not adjust the pressure setting to the pump or valve.
 - Do not check for leaks with your hands. Leaks can be located by holding a piece of cardboard or wood (at least 2 feet long) with your hand at one end and passing the other end suspected area (wear eye protection). Look for discoloration of the cardboard or wood.
 - If injured by escaping fluid, no matter how small the wound is, see a doctor at once. A typical injection injury may be a small puncture that does not look serious. However, severe infection or reaction can result if proper medical treatment is not administered immediately by a doctor who is familiar with injection injuries.

Problem	
Wedge will not move	Solution: A,D,E,H,J
Slow wedge speed when extending or retracting	Solution: A,B,C,H,I,K
Wood will not split or splits extremely slow	Solution: A,B,C,F,I,K
Engine bogs down during splitting	Solution: G
Engine stalls under low load condition	Solution: D,E
Cause	Solution
A- Insufficient oil to pump	Check oil level in reservoir
B- Air in oil	Check oil level in reservoir, check for leaks in the suction line
C- Excessive pump inlet vacuum	Check pump inlet hose for blockage or kinks
D- Blocked hydraulic lines	Flush and clean the splitter hydraulic system
E- Blocked control valve	Flush and clean the splitter hydraulic system
F- Low control valve setting	Adjust control valve with a pressure gauge
G- High control valve setting	Adjust control valve with a pressure gauge
H- Damaged control valve	Return control valve for authorized repair
I- Internal control valve leak	Return control valve for authorized repair
J- Damaged cylinder piston	Return cylinder for authorized repair
K- Internally damaged cylinder	Return cylinder for authorized repair

Any Questions, Comments, Problems or Parts Orders
Call NorthStar Product Support 1-800-270-0810

Specifications

1108, 1109, 1114

Hydraulic Fluid Type.....	10wt AW32, ASLE H-150, or ISO32
Coupler Size.....	2” Ball
Maximum Towing Speed.....	45 MPH
Maximum Log Length	25 in
Hydraulic Cylinder Stroke	24 in
Overall Dimensions	89”L x 43”W x 41”H

	1108	1109	1114
Flow.....	11 GPM	11 GPM	16 GPM
Pressure.....	3000 PSI	3500 PSI	3500 PSI
Hydraulic Oil Capacity.....	8 GAL.	8.5 GAL.	9 GAL.
Hydraulic Cylinder Bore.....	4”	4.5”	5”
Spark Arrestor.....	No	No	Yes
Fuel Valve.....	No	Yes	Yes
Dry Weight.....	490 lb	530 lb	565 lb
Tonnage.....	22 TON	30 TON	37 TON

The manufacturer reserves the right to make improvements in design and/or changes in specifications at any time without incurring any obligation to install them on units previously sold.

Any Questions, Comments, Problems or Parts Orders
Call NorthStar Product Support 1-800-270-0810

Parts Breakdown – Exploded View 1108, 1109, 1114 – Rev J

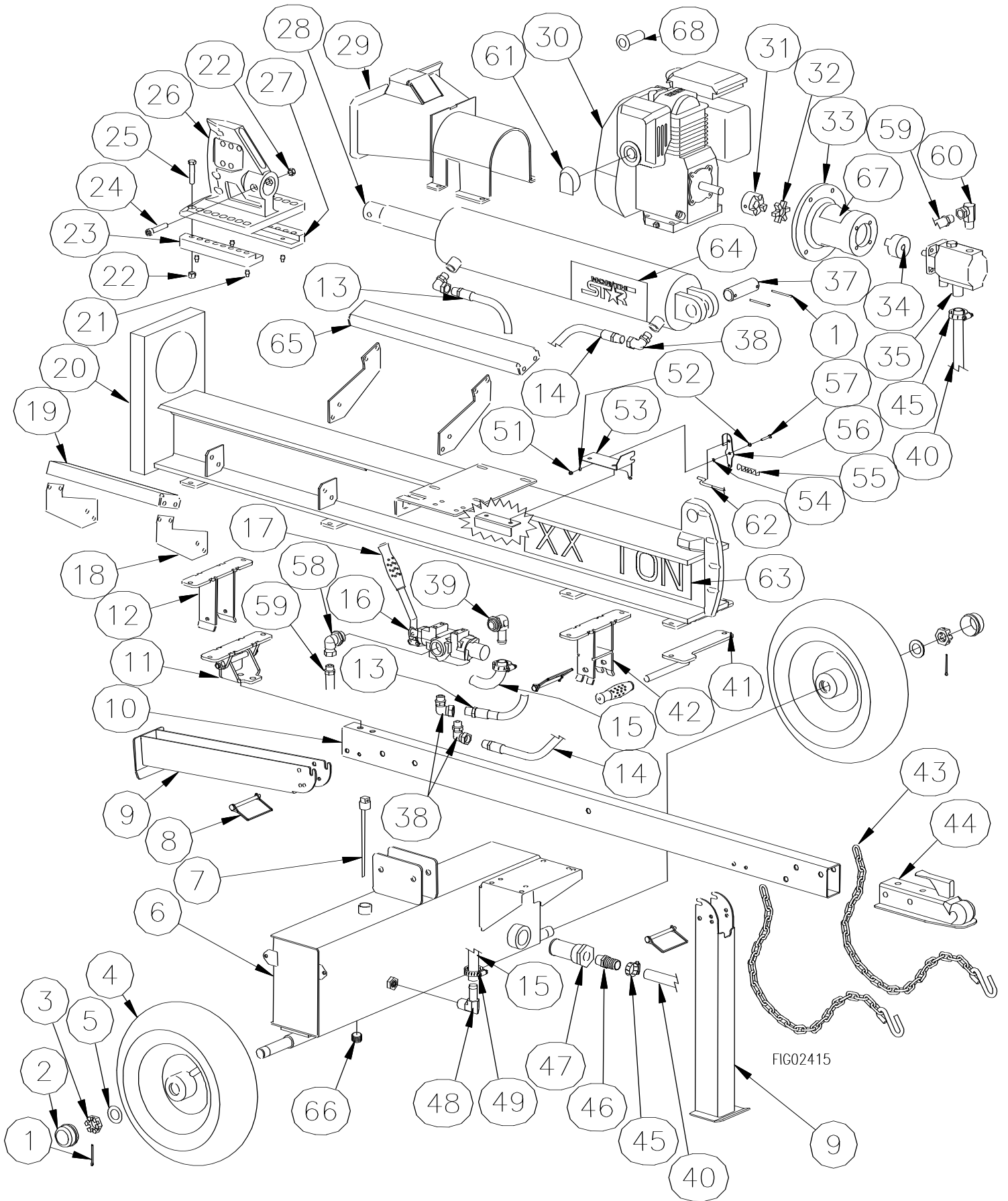

Parts Breakdown – Exploded View 1108, 1109, 1114 – Rev J

Item	Part No.	Description	Qty.	Model
1	82140	1/8" x 2" COTTER PIN	4	ALL
2	124A	DUST CAP	2	ALL
3	777124	AXLE NUT	2	ALL
4	777799	WHEEL	2	ALL
5	778844	WHEEL WASHER	2	ALL
6	780265	AXLE/TANK	1	ALL
7	778424	DIPSTICK	1	ALL
8	778498	CATCH PIN	3	ALL
9	778876	OUTRIGGER LEG	2	ALL
10	778403	TOWBAR	1	ALL
11	779324	TIP-UP PIVOT	1	ALL
12	778578	VERTICAL BEAM LOCK	1	ALL
13	778619	1/2" NPT HP HOSE	1	ALL
14	778619	1/2" NPT HP HOSE	1	ALL
15	778615	46" RETURN LINE	1	ALL
16	778435	CONTROL VALVE	1	1108
	778624			1109
	778435			1114
17	34025	HAND GRIP	1	ALL
18	779174	LOG CRADLE SUPPORT	4	ALL
19	778431	LOG CRADLE FACE PLATE	1	ALL
20	778325	BEAM	1	ALL
21	778873	8mm GREASE ZERK	4	ALL
22	82115	7/16-14 NYLON NUT	17	ALL
23	778380	WEDGE KEEPER, LEFT	1	ALL
24	82258	7/16-14 X 2 1/4" SHCS	1	ALL
25	82114	7/16-14 X 2" HHCS GRD 8	16	ALL
26	778321	WEDGE	1	ALL
27	778723	WEDGE KEEPER, RIGHT	1	ALL
28	778363	4 X 24" CYLINDER	1	1108
	778341	4.5 X 24" CYLINDER		1109
	778362	5 X 24" CYLINDER		1114
29	778736	LOG STRIPPER	1	1108
	778735			1109
	778734			1114
30	60599	HONDA GC160, 5.0 HP	1	1108
	60590	HONDA GX160, 5.5 HP		1109
	39115	HONDA GX270, 9.0 HP		1114
31	3005	3/4" COUPLING	1	1108,1109
	3007	1" COUPLING	1	1114
32	3009	COUPLING INSERT	1	ALL
33	3030 779683	PUMP MOUNT BRACKET	1	1108,1109 1114

Item	Part No.	Description	Qty.	Model
34	3002	1/2" COUPLING	1	ALL
35	1012	11 GPM 2-STAGE PUMP	1	1108, 1109
	1056	16 GPM 2-STAGE PUMP		1114
37	778592	CYLINDER ANCHOR PIN	1	ALL
38	778827	O-RING BOSS X NPT ELBOW	4	ALL
39	778642	O-RING BOSS X HB ELBOW	1	ALL
40	778616	3/4" SUCTION HOSE	18"	1108, 1109
	778634	1" SUCTION HOSE	20.5"	1114
41	778885	HANDLE	1	ALL
42	778343	HORIZONTAL BEAM LOCK	1	ALL
43	1130	SAFETY CHAIN	2	ALL
44	38587	2" COUPLER	1	ALL
45	17141	1/2" HOSE CLAMP	2	1108, 1109
	777835	13/16" – 1 3/4" HOSE CLAMP	2	1114
46	5267	3/4" MPT X 3/4" HB	1	1108, 1109
	38050	3/4" MPT X 1" HB	1	1114
47	4011	4" SUCTION STRAINER	1	ALL
48	778829	3/4" NPT X 3/4" HB ELBOW	1	ALL
49	777835	13/16" – 1 3/4" HOSE CLAMP	2	ALL
51	82065	#10-24 NYLON NUT	1	1109, 1114
52	31094	#14S BRASS WASHER	2	1109, 1114
53	778808	IDLE CONTROL BASE	1	1109, 1114
54	31095	1/4 NYLON WASHER	1	1109, 1114
55	37991	EXTENSION SPRING	1	1109, 1114
56	778470	IDLE CONTROL ARM	1	1109, 1114
57	82058	1/4" X 1/4" SHOULDER BOLT	1	1109, 1114
58	778831	O-RING X SWIV. FEM. NPT	1	ALL
59	778618	1/2" MALE NPT HP HOSE	1	ALL
60	50RAS8	1/2" M X 1/2" F SWIVEL NPT	1	ALL
61	778709	MUFFLER DEFLECTOR	1	1108
62	38477	IDLE CONTROL CABLE	1	1109, 1114
63	778513	22 TON DECAL	2	1108
	778512	30 TON DECAL		1109
	778511	37 TON DECAL		1114
64	STNS4	NORTHSTAR DECAL	2	ALL
65	779331	LOG CRADLE WELDMENT	1	ALL
66	30511	DRAIN PLUG	1	ALL
67	779681	GUARD INSERT FOR 779683	2	1114
68	39116	SPARK ARRESTOR	1	1114
	39129	SPARK ARRESTOR SCREW	1	1114

Summary of Important Safety Information for Operation

WARNING

Carefully read and make sure you understand the following safety information before using the log splitter. Improper use or maintenance of the log splitter can result in serious injury to the operator or bystanders from moving parts that can crush or cut, flying objects, burns, fire or explosion, escaping high pressure hydraulic fluid, or carbon monoxide poisoning.

Introduction

- **Read Manual.** Read this operator's manual and the engine Owner's Manual completely before attempting to use the log splitter. Serious injury or death can result if safety instructions are not followed.
- **Instruct operators.** The log splitter owner should instruct all operators in safe log splitter operation.
- **Intended use.** Log splitters should only be used for splitting wood logs, lengthwise with the grain. Do not use for other purposes, as unforeseen hazards may result.

Prohibition Against Modifications

Never modify or alter the log splitter in any way. Modifications can create serious safety hazards and will void the warranty.

- **Attachments.** Never add attachments to the splitter, except for authorized accessories supplied by the manufacturer with instructions for safe installation and use.
- **Engine Speed.** The maximum engine speed is preset at a safe limit. Never attempt to modify the engine speed setting to run at a higher speed.
- **Fuel/Exhaust system.** NEVER modify or add to the exhaust system, fuel tanks, or fuel lines. Fire can result.
- **Remote Control.** NEVER attach a rope, cable, or other remote device to the splitting control.
- **Splitting Wedge.** NEVER attempt to change the height or speed of the splitting wedge.
- **Pressure Setting.** NEVER increase the pressure setting of the pump or control valve.

Operator Restrictions

- **Untrained Operators.** Do not allow anyone to operate the log splitter who has not read the owner's manual or been instructed on the safe use of the splitter.
- **Minimum Operator Age.** Never allow anyone under age 16 to operate the log splitter. Anyone 16 years of age and older must be trained and supervised by a trained adult.

Safety in Moving and Towing the Log Splitter

WARNING

The log splitter is very heavy. It can cause serious injury if it rolls out of control or tips over.

Follow the safety instructions below for safely moving the log splitter.

General safety while Moving

- **Horizontal position.** Make sure the log splitter is secured in the horizontal position before moving the log splitter. DO NOT move the log splitter when it is in the vertical position because it will be unstable and could tip.
- **Hills.** Do not move the log splitter up or down hills by hand – use a towing vehicle.
- **Engine off.** Never move the log splitter with its engine running.
- **No riding.** Never allow anyone to sit or ride on the log splitter.
- **No cargo.** Never transport cargo or wood on the log splitter.

Safety During Towing

- **Read instructions.** Review towing safety instructions in your towing vehicle manual.
- **Securely attached.** Be sure the log splitter is securely attached to the towing vehicle before towing.

Summary of Important Safety Information for Operation

- **Tires.** Be sure the tires are fully inflated and in good repair before towing the log splitter. When adding air to the tires, do not over-inflate – serious injury could occur if tire explodes.
- **Added length.** Be aware of the added length of the splitter.
- **Speed Limit.** Never tow this log splitter over 45 mph. Faster speeds may result in loss of control.
- **Rough terrain.** Be extra cautious and drive slowly when traveling over rough terrain.
- **Under the influence.** Never tow this splitter while under the influence of alcohol, drugs, or medication.
- **On public roads.** If towing on a public road, make sure to comply with all local, state, and federal towing requirements. It is the sole responsibility of the purchaser to obtain licensing, trailer lights, safety chains or signage, as needed to comply.
- **Unattended.** Turn off the towing vehicle before leaving the splitter unattended.
- **Disconnect before operate.** Do not use the log splitter while it is connected to the towing vehicle.

Safety – Before Use Read/instruct

- **Read manual.** Do not allow anyone to operate the log splitter who has not read the owner’s manual or has not been instructed on the safe use of the splitter.
- **Review safety rules.** Before starting this log splitter, review the “Rules for Safe operation.” Failure to follow these rules may result in serious injury to the operator or bystanders.
- **Know how to stop.** Be thoroughly familiar with all controls and proper use of the equipment. Know how to stop the splitter and relieve system pressures quickly if needed.

Personal protective equipment

- **Eye protection.** Always wear safety glasses or goggles when operating the machine. Pieces of log may fly out and serious eye injury can occur.
- **Boots.** Falling logs can crush feet. Always wear safety shoes or heavy boots when operating or helping to load logs.
- **Loose/dangling.** Loose or dangling apparel can become entangled in moving parts. Never wear jewelry or loose-fitting clothing.
- **Gloves.** Wear snug fitting gloves without drawstrings or loose cuffs.
- **Hearing Protection.** The use of earplugs or other hearing protection device is recommended.

Safety During Inspection/Maintenance

Always inspect your log splitter before each use, and repair as needed, to keep it in safe working condition:

- **Engine off.** Always make sure the engine is off before cleaning, repairing or adjusting the splitter, except as recommended by the manufacturer.
- **Engine debris.** Debris on a hot engine can be a fire hazard. With the engine off, clean debris and chaff from engine cylinder head, cylinder head fins, blower housing rotating screen, and muffler areas. Avoid contact with hot muffler.
- **Other debris.** Debris on moving parts can cause excess wear. With the splitter engine off, clear debris from moving parts.
- **Fuel tank / lines.** Before each use, check fuel tank and fuel lines for leaks. Any fuel leak is a fire hazard. Fix any fuel leaks before starting engine.
- **Mechanical parts.** Check to be sure that all nuts and bolts are tight to make sure the log splitter is in safe working condition.
- **Hydraulic system.** Check the hydraulic system (hoses, tubing, clamps/fittings, pump, and cylinder) carefully before each use. Do not operate the log splitter with frayed, kinked, cracked or damaged hydraulic hoses, fittings, or tubing, or if oily residue is observed on any of the components. High fluid pressures and temperatures are developed in the log splitter. Hydraulic fluid escaping through a pin hole sized opening can burn or puncture skin, resulting in wounds that could cause blood poisoning, infection, disability, gangrene, amputation, or death. Therefore, the following instructions should be heeded at all times when inspecting or servicing the hydraulic components of the log splitter:
 - Do not remove the hydraulic oil dipstick when the engine is running. Hot oil can escape causing severe burns. Allow log splitter to cool completely before removing hydraulic oil dipstick.
 - Do not adjust the pressure setting of the pump or valve.

Summary of Important Safety Information for Operation

- o Do not check for leaks with your hand. Leaks can be located by holding a piece of cardboard or wood (at least two feet long) with your hand at one end and passing the other end over the suspected area (wear eye protection). Look for discoloration of the cardboard or wood.
- o Stop the engine, disconnect the spark plug, and move all control valve handles back and forth to relieve pressure before changing or adjusting hydraulic system components such as hoses, tubing, fittings or other components.
- o If injured by escaping fluid, no matter how small the wound is, see a doctor at once. A typical injection injury may be a small puncture wound that does not look serious. However, severe infection or reaction can result if proper medical treatment is not administered immediately by a doctor who is familiar with injection injuries.
- **Spark arrestor muffler.** If the engine is equipped with a spark arrestor muffler, clean and inspect it regularly (follow manufacturer's service instructions). Replace if damaged.
- **Tires.** Be sure tires are fully inflated and in good repair before towing the splitter. When adding air to tires, do not over-inflate -- serious injury could occur if tire explodes.
- **Guards / shields.** Make sure all guards and shields are replaced after servicing the log splitter.
- **Replacement parts.** If a part needs replacement, only use parts that meet the manufacturer's specifications. Replacement parts that do not meet specifications may result in a safety hazard or poor operation of the log splitter.

Safety During Fueling

- Gasoline is highly flammable and explosive. You can be burned or seriously injured when handling fuel. Use extreme care when handling gasoline:
- **Fuel outdoors.** Fill fuel tank outdoors – never indoors. Gasoline vapors can ignite if they collect inside an enclosure. Explosion can result.
- **Use approved container.** Never pump fuel directly into engine at gas station. Static charge can build and ignite fuel. Use an UL approved fuel container to transfer gas to the engine.
- **Running / hot engine.** A running engine is hot enough to ignite fuel. Never add fuel or remove gas cap if engine is running or still hot. Stop the engine and allow to cool at least two minutes before adding fuel.
- **Heat / flames / sparks.** Stay away from sources of heat, flame, or sparks while adding fuel.
- **Don't overfill.** DO NOT overfill the gas tank. Allow at least 1/2" of empty space below the fill neck to allow for fuel expansion.
- **Replace cap.** Replace gas cap securely before starting engine.
- **Spills.** Clean up fuel spills immediately. Move log splitter away from spilled fuel on the ground. Wipe fuel off engine and wait 5 minutes for excess fuel to evaporate before starting engine. Gas soaked rags should be disposed of properly.
- **On skin / clothes.** If gasoline is spilled on your skin or clothes, change clothes and wash skin immediately.
- **Gasoline storage.** Store gasoline in a cool, dry place in an UL approved, tightly sealed container.

Safety in Work Site Selection

- **Spark arrestor.** If your splitter will be used near any unimproved forest, brush, or grassy covered land, then engine should be equipped with a spark arrestor. See the "Specifications" section of this manual to determine if your splitter already has a spark arrestor. Make sure you comply with applicable local, state and federal codes.
- **Hot exhaust.** Hot exhaust fumes from engine can cause fire. Position muffler at least 7' from combustible objects during operation.
- **Fire extinguisher.** Have a Class B fire extinguisher available as a precautionary measure when operating the log splitter in dry areas.
- **Level, dry surface.** To prevent accidental falls and equipment tip over, make sure the splitter is situated on a dry, level surface with good footing. Stay clear of areas with mud, ice, tall grass, weeds, brush, or snow.
- **Block wheels.** Always block the wheels to prevent unintended movement of the log splitter.
- **Carbon monoxide.** The running engine gives off carbon monoxide, a poisonous gas that can kill you. You CANNOT smell it, see it, or taste it. ONLY run log splitter OUTDOORS and away from air intakes. NEVER run log splitter inside homes, garages, sheds, or other semi-enclosed spaces. These spaces can trap poisonous gases, EVEN if you run a fan or open windows. If you start to feel sick, dizzy, or weak while using the log splitter, shut off the engine and get to fresh air RIGHT AWAY. See a doctor. You may have carbon monoxide poisoning.

Summary of Important Safety Information for Operation

Safety – During Use General Safety During Use

⚠️ WARNING: Before starting this log splitter, review the following rules for safe operation. Failure to follow these rules may result in serious injury to the operator or bystanders.

- **Safety equipment / controls.** Always operate the log splitter with all safety equipment in place and in good working order, and all controls properly adjusted for safe operation.
- **Operating speed.** Always operate the log splitter at the manufacturer's recommended speed. The maximum speed of the engine, pump and wedge are preset within safe limits.
- **Know how to stop.** Be thoroughly familiar with all controls and with the proper use of the equipment. Know how to stop the log splitter and relieve system pressures quickly if needed.
- **Daylight only.** Only use the log splitter in daylight so you can see what you are doing.
- **Smoking / sparks.** Never smoke while operating the log splitter, and never operate near sources of sparks or flames.
- **Hot muffler.** If you are starting a warm engine, stay clear of muffler. It may still be hot enough to burn you.
- **Unattended.** Never leave the machine unattended while the engine is running.
- **Under the influence.** Never operate, or let anyone else operate, the log splitter while under the influence of alcohol, drugs, or medication.
- **Adjusting / repairing.** Always make sure the engine is off before cleaning, repairing or adjusting the splitter, except as recommended by the manufacturer. In addition, disconnect the spark plug and move all control handles back and forth to relieve system pressure *before changing or adjusting hydraulic system components* such as hoses, tubing, fittings or other components.
- **Carbon monoxide.** The running engine gives off carbon monoxide, a poisonous gas that can kill you. You CANNOT smell it, see it, or taste it. If you start to feel sick, dizzy, or weak while using the log splitter, shut off the engine and get to fresh air RIGHT AWAY. See a doctor. You may have carbon monoxide poisoning.
- **Other exhaust dangers.** Engine exhaust, some of its constituents, and certain vehicle components contain or emit chemicals known to the State of California to cause cancer, birth defects, or other reproductive harm. Avoid inhalation of exhaust.

Safety in Loading, Operating, and Unloading

- **Square log ends.** Logs that are not cut square can slide out while splitting and become a safety hazard or cause excessive force to log splitter components. Use a chainsaw to cut logs square on each end before attempting to split them.
- **Single log.** Never attempt to split more than one log at a time. Pieces of log can unexpectedly be thrown from the machine causing serious injury.
- **Split along grain.** Do not use the log splitter to split logs across the grain. Doing so will damage the log splitter and could also cause pieces of log to be thrown, injuring the operator or bystanders.
- **Keep hands clear.** ALWAYS keep hands and feet away from the endplate, wedge, and partially split logs while loading, operating and unloading the log splitter.
- **Operator position.** ALWAYS operate the log splitter from the manufacturer's indicated OPERATOR POSITION. Other positions are unsafe because they can increase the risk of injury from crushing, cutting, flying objects, or burns.
- **Straddling / reaching across.** Never straddle, reach across, or step over the beam while the engine is running and the log splitter is in the horizontal position. You could trip, actuate the controls, and get seriously injured.
- **Second person.** Many accidents occur when there is more than one person involved in loading and operating the log splitter. Only one person should operate the controls. *If a second person is assisting in loading logs, the operator must NEVER actuate the Split Control Lever until the assistant and all bystanders are at least 10 feet away. NEVER allow an assistant to hold the log in place while the operator actuates the Split Control Lever.*
- **Loading/Unloading**
- **Unsplit log pile.** Do not pile logs to be split in a place that will make you reach across the log splitter in order to load them.
- **Hold bark side.** Hold the bark side of logs when loading or positioning, never the ends. Never place your hands or any part of your body between a log and any part of the log splitter.

Summary of Important Safety Information for Operation

- **NOTE for vertical position loading:** Place the log on the endplate and turn it until it leans against the beam and is stable. If the log is too big or oddly shaped, stabilize the log with wooden shims between the log and endplate or ground. DO NOT use your leg or knee to stabilize the log. NEVER stabilize the log by placing your hand on top of the log.
- **Wedge moving.** NEVER load or unload logs while the wedge is moving.
- **Cracks.** Cracks in logs can close quickly and pinch fingers. Keep fingers away from any cracks that open in partially split logs.
- **Split log pile.** Move each log away from log splitter after it is split. Split logs left near the log splitter are a trip hazard.
- **Remove hands.** Remove both hands from log before activating Split Control Lever.
- **Hand activate.** Use only your hand to operate the Split Control Lever. Never use any other body part, or a rope, cable, or other remote device to actuate the control.
- **Returning wedge.** Once the control valve is actuated in the return direction, the wedge is designed to keep returning by itself completely and then stop automatically. Stay clear while the wedge is returning. It is still powerful enough on the return stroke to cause serious injury.
- **Log stuck on wedge.** If a log does not split completely and becomes stuck on the wedge, follow the instructions below to remove the log. A log can become stuck to the wedge if the wedge becomes embedded in the log and the log doesn't split and separate. This can happen if the log is too stringy or tough to split completely. A stuck log will move back with the wedge on the initial attempt to retract the wedge. If this happens, retract the wedge completely to allow the splitter to strip the log from the wedge. Keep hands clear of log and wedge while wedge is retracting.

▲WARNING: NEVER attempt to remove a stuck log by:

- Modifying the splitter.
- Adding attachments to the splitter.

Personal injury could result from log or metal pieces flying out at high speed toward the operator or bystanders, or the splitter could become damaged.

- **Changing splitting position.** Do not change splitting positions (horizontal/vertical) with the engine running. You may contact the muffler and receive serious burns. Be careful to avoid contact with hot muffler even after the engine is turned off.
- **Refueling.** Never refuel the engine until it has cooled at least two minutes.

Safety – After use

- **Return to horizontal.** If in the vertical position, turn off engine and return log splitter to the horizontal position for greater stability and to prepare for transportation. Avoid contact with hot muffler.
- **Remove engine debris.** Debris on a hot engine can be a fire hazard. With the engine off, clean debris and chaff from engine cylinder head, cylinder head fins, blower housing rotating screen, and muffler areas. Avoid contact with hot muffler.
- **Let engine cool before storing.** Let engine cool for at least five minutes before storing. A hot engine can be a fire hazard.
- **Storage location.** Store the log splitter in a location away from sources of heat, open flames, sparks or pilot lights – such as water heaters, space heaters, furnaces, clothes dryers, or other gas appliances. Even if the log splitter's gas tank is empty, residual gasoline vapors could ignite.
- **Gasoline storage.** Store extra gasoline in a cool, dry place in an UL approved, tightly sealed container. Gasoline vapors can ignite if they collect inside an enclosure.
- **Periodic maintenance.** Perform periodic maintenance as directed in this manual to keep the log splitter in safe working condition.

Assembly Instructions

Closely inspect all log splitter components.

If you have missing components, contact Product Support at 1-800-270-0810.

If you have damaged components, contact the Freight Company that delivered the unit and file a claim.

CAUTION! Heavy lifting required. Some of the components in these assembly instructions are heavy and cannot be lifted by one person safely. Please plan on assembling this product when another person can be available to help out.

Tools needed: Adjustable wrenches Torque Wrench, Soft Faced Mallet, Flat Blade Screw Driver

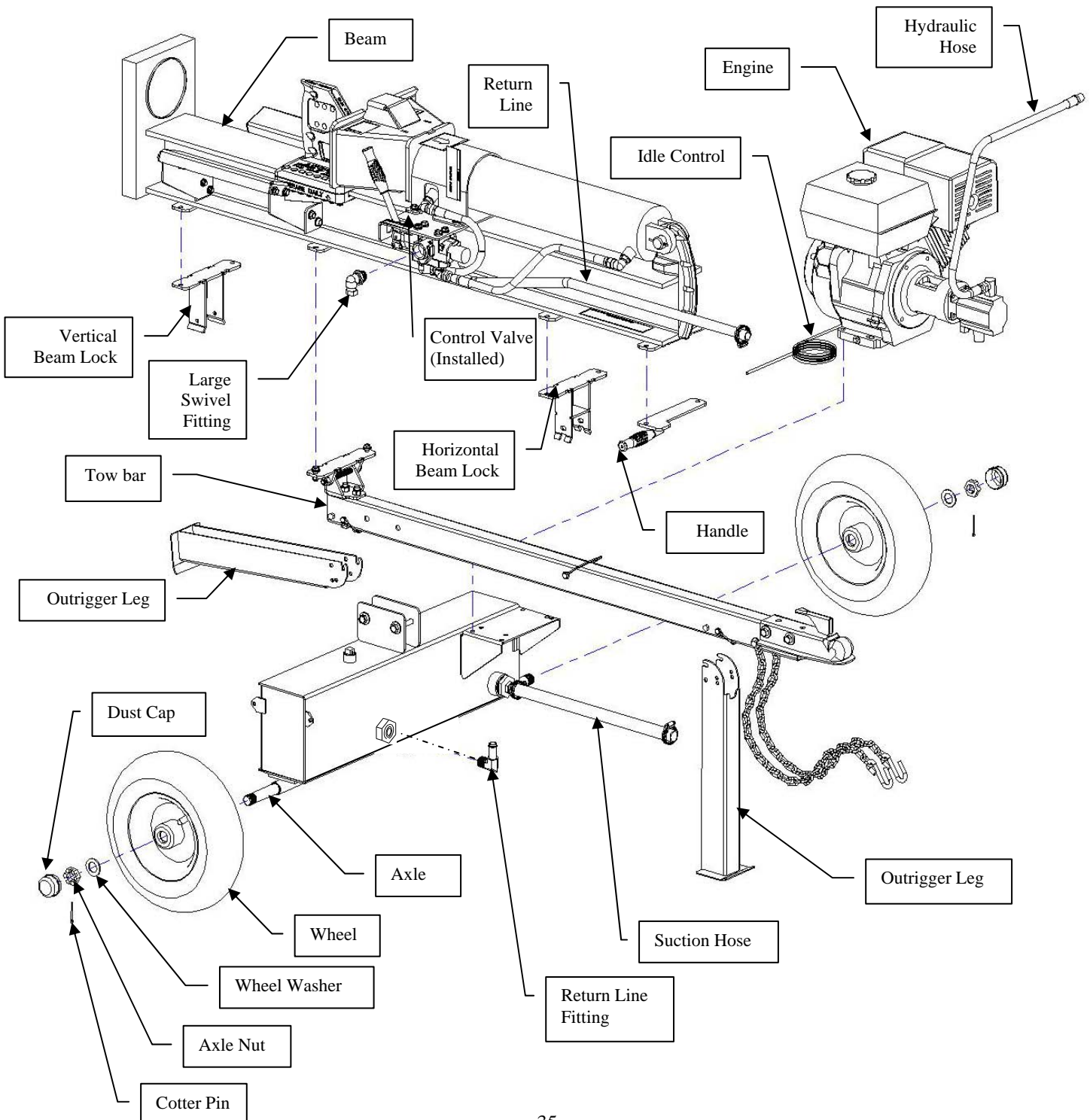

Assembly Instructions

FASTENER IDENTIFICATION

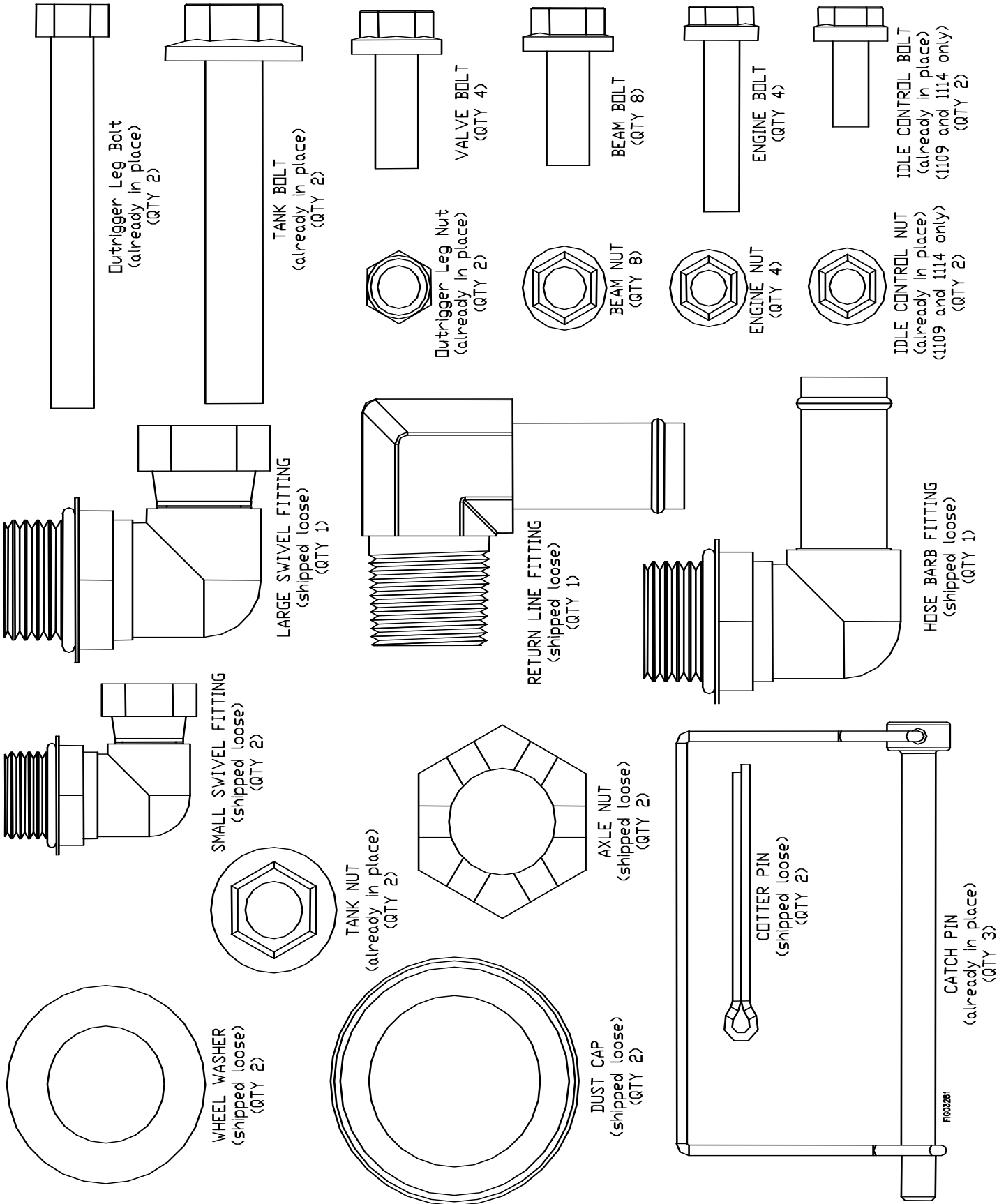

* Not shown: Spark arrestor & screw, Item #1114 ONLY

Assembly Instructions

Assembly Instructions

Step 1

- Remove shipping crate (red bumpers can be thrown away, if equipped)
- If there are rubber boots on the axles, remove and discard them
- Slide Wheel onto Axle with Valve Stem facing out
- Slide Outer Bearing onto Axle (outer bearing may be shipped loose in parts bag or loose inside wheel)
- Outer bearing taper points into log splitter
- Slide Wheel Washer onto Axle

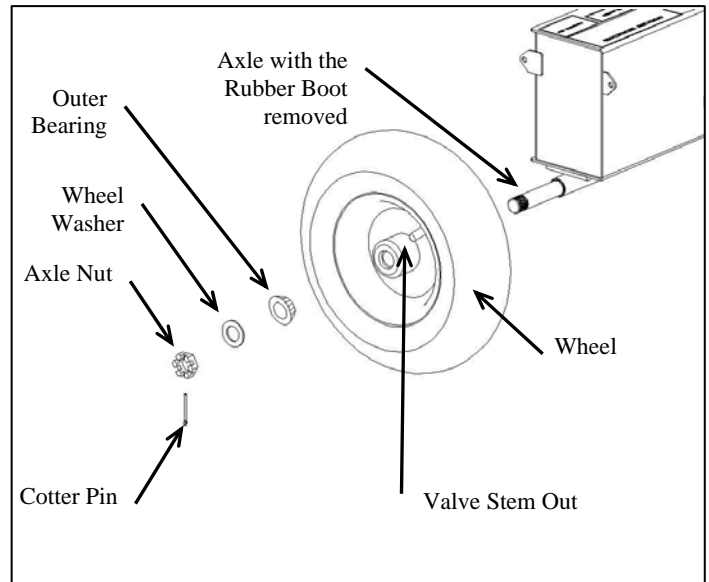

Step 2

- Thread Axle Nut onto Axle (hand tight)
- Back Axle Nut off $\frac{1}{4}$ turn
- Make sure Wheel spins freely
- Insert Cotter Pin through hole in Axle and bend it so Axle Nut cannot come off
- Make sure Wheel spins freely
- Tap Dust Cap onto Wheel with a soft faced mallet
- Repeat steps 1 and 2 for the other Wheel

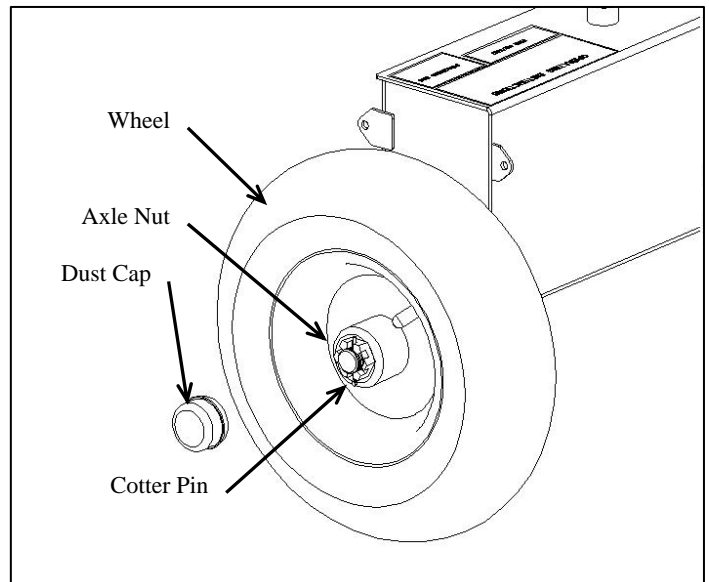

Step 3

- Connect Towbar to Axle/Tank using (2) Tank Bolts and (2) Tank nuts (already in place)
- Tighten Bolts to 90 lb-ft with a wrench

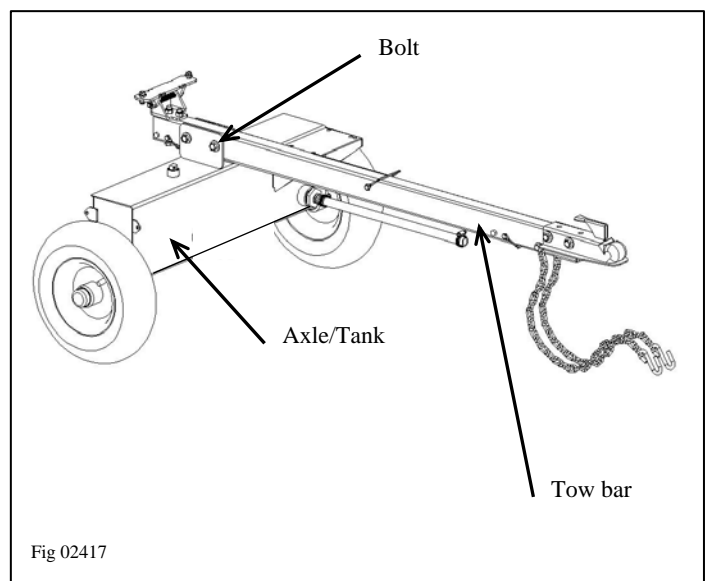

Assembly Instructions

Step 4

- Connect an Outrigger Leg to front of Towbar using (1) Outrigger Leg Bolt and (1) Outrigger Leg nut (already in place)
- Use wrench to tighten nut until snug then back off ½ turn
- Insert Catch Pin to lock outrigger leg in vertical position
- Caution: Next step requires Outrigger Leg locked in vertical position as shown

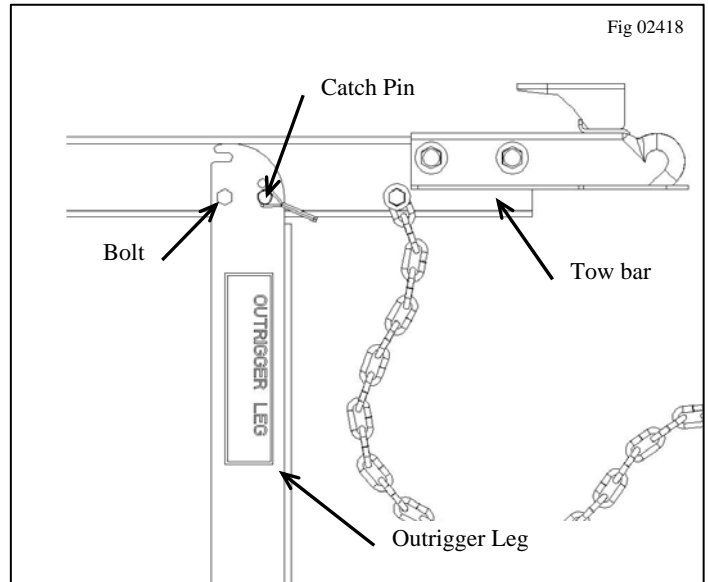

Step 5

- Connect an Outrigger Leg to back of Towbar using (1) Outrigger Leg Bolt and (1) Outrigger Leg nut (already in place)
- Use wrench to tighten nut until snug then back off ½ turn
- Insert Catch Pin to lock outrigger leg in vertical position
- Caution: Next step requires Outrigger Leg locked in vertical position as shown

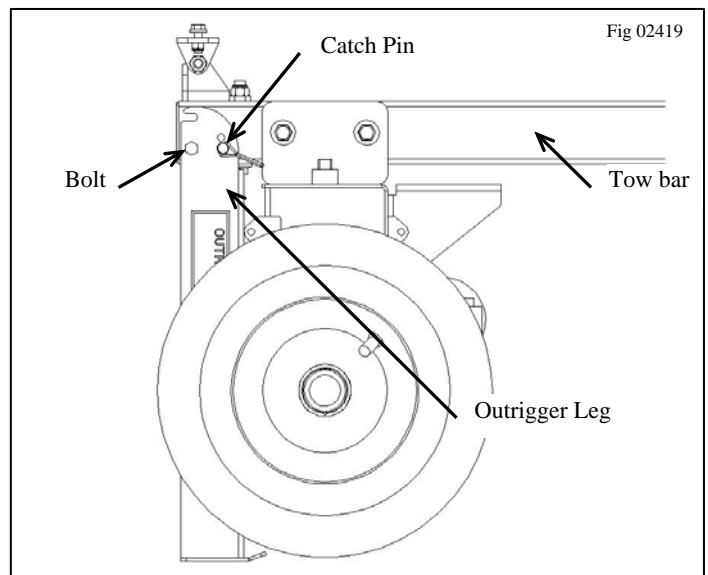

Step 6

- Remove Beam from shipping pallet
- Tip Beam up onto endplate as shown to the right. Make sure a helper holds onto the top of the Beam during the remainder of this step. The beam is very heavy and dangerous if it tips over
- Connect Beam to the Towbar with (2) Beam Bolts and (2) Beam nuts
- Tighten Bolts to 37 lb-ft with a wrench

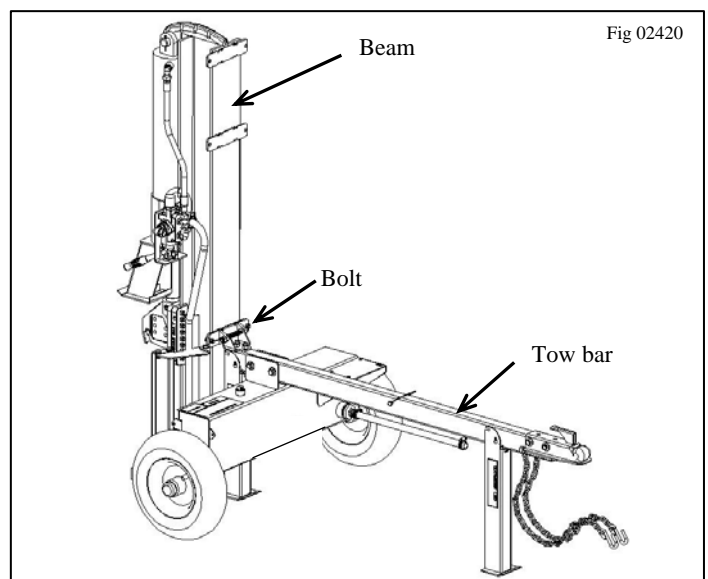

Assembly Instructions

Step 7

- Fasten Horizontal Beam Lock to Beam using (2) Beam Bolts and (2) Beam nuts
- Tighten Bolts to 37 lb-ft with a wrench
- Fasten Handle to Beam as shown using (2) Beam Bolts and (2) Beam nuts
- Tighten Bolts to 37 lb-ft

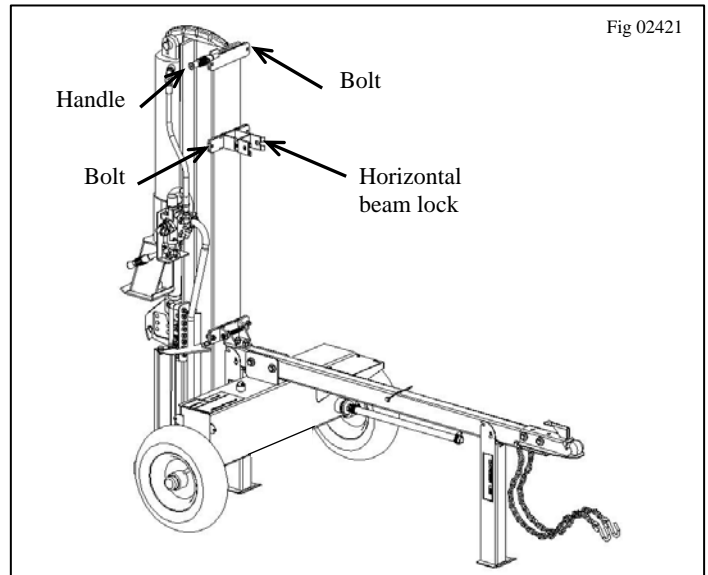

Step 8

- Lower Beam to horizontal position as described in the SPLITTING OPERATION section of the manual
- Fasten Vertical Beam Lock to Beam using (2) Beam Bolts and (2) Beam nuts
- Tighten Bolts to 37 lb-ft

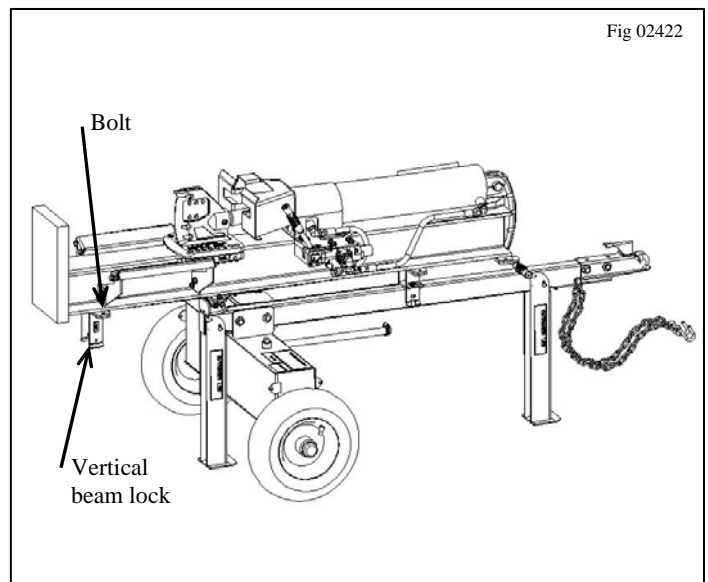

Step 9a

- Mount Engine to Axle/Tank using (4) Engine Bolts and (4) Engine nuts
- Tighten Bolts to 24 lb-ft

(Beam not shown for clarity)

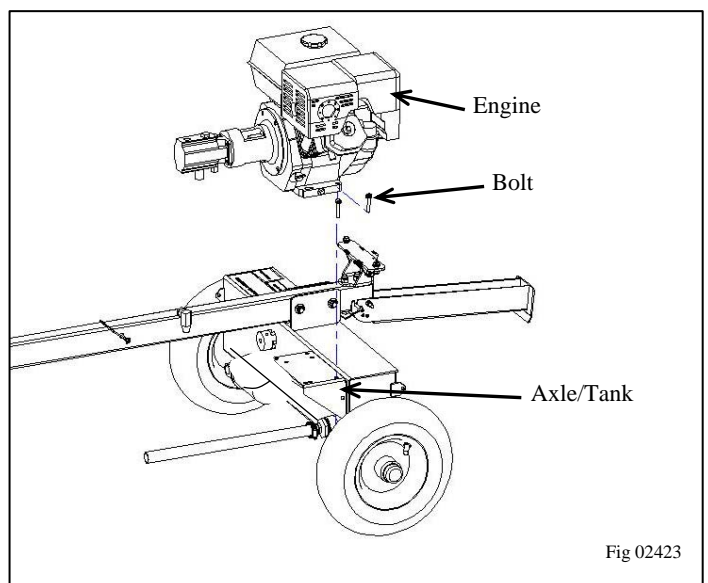

Assembly Instructions

Step 9b

- Engine mounting pattern shown for reference

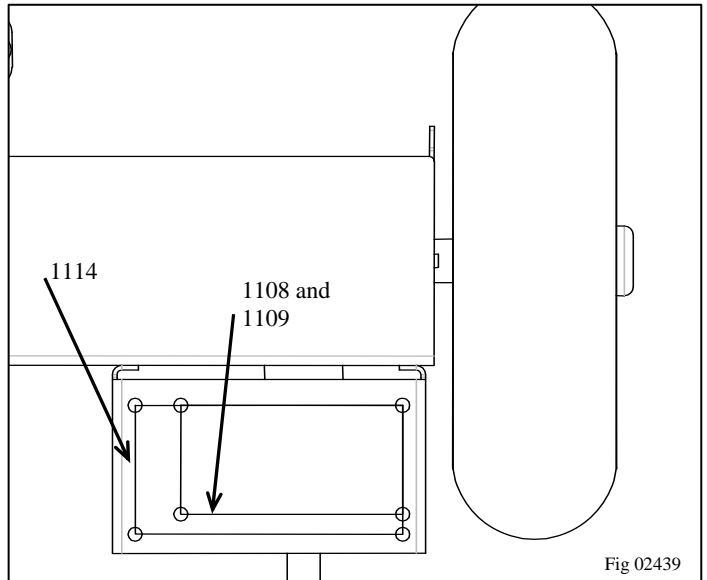

Step 10

- Slightly loosen Hose Clamp on loose end of Suction Hose
- Remove shipping plug from pump then slide Suction Hose onto the bottom fitting of the pump
- Secure the Suction Hose with the Hose Clamp
- Install Spark Arrestor (Item #1114 only) per Honda Engines Owner's Manual under Servicing your Honda engine.

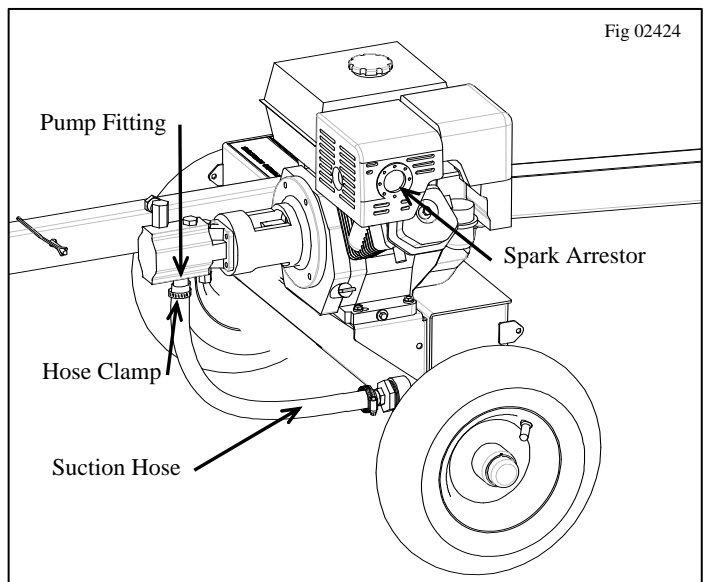

Step 11a

(Item #'s 1109 and 1114 models only)

- Attach Idle Control Plate to Idle Control Mount plate on the Beam using (2) Idle Control Bolts and (2) Idle Control nuts (already in place)

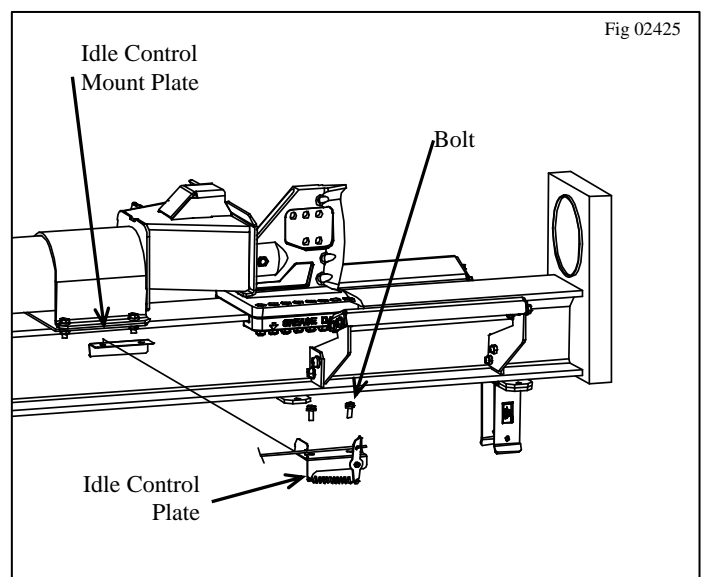

Assembly Instructions

Step 11b

(1109 and 1114 models only)

- Tighten Idle Control Bolts to 20 lb-ft with a wrench

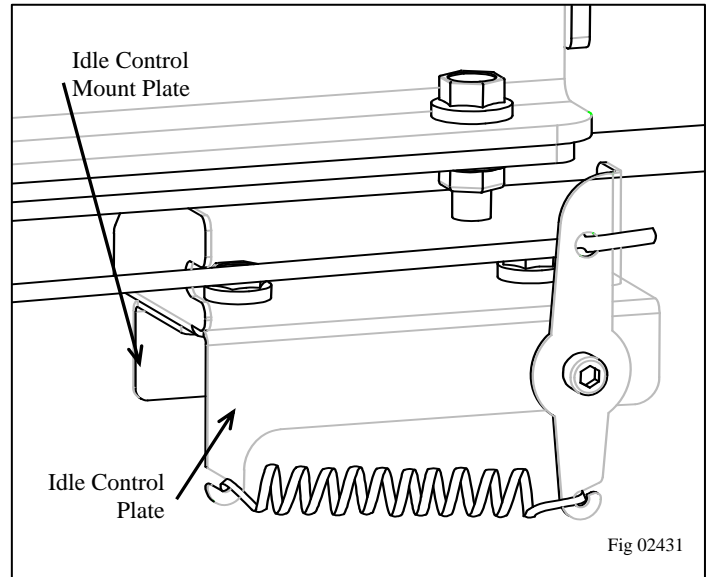

Step 12

- Thread the Return Line Fitting into the hydraulic tank (Finger tight plus turn 1½ to 3 additional turns) and position the hose barb up as shown

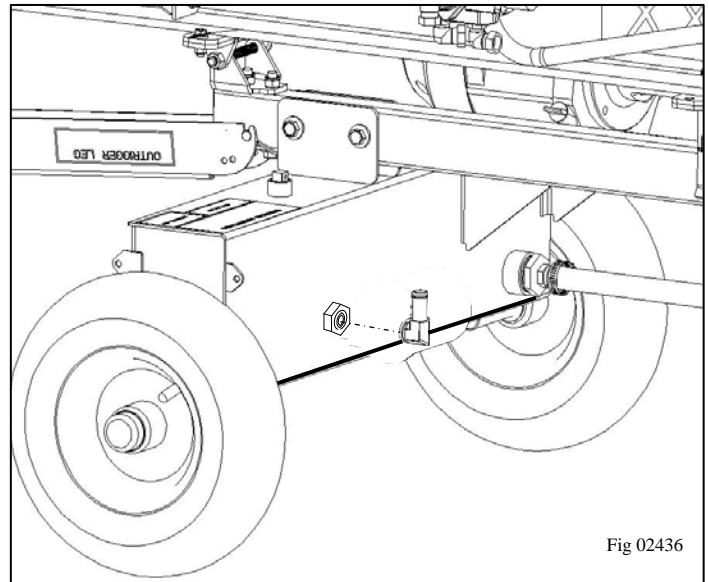

Step 13

- Remove plugs from the (3) ports.
- Thread the Small Swivel Fittings into ports marked "A" and "B" on the Control Valve.
- Thread Hose Barb Fitting into Port marked OUT on the Control Valve.
- Tighten the Swivel Fittings and Hose barb fitting finger tight and Orient the Fittings as shown, Tighten the Nuts into Control Valve with a Wrench to 44-54 lb-ft)

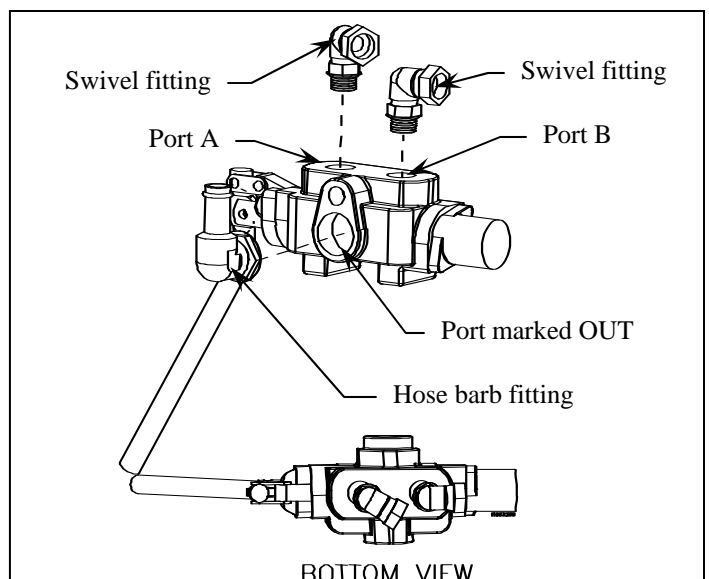

Assembly Instructions

Step 14

- Mount Control Valve to Beam using (4) 3/8-16 x 1/2" Valve Bolts
- Tighten Bolts to 20 lb-ft
- Push on Control Valve Grip

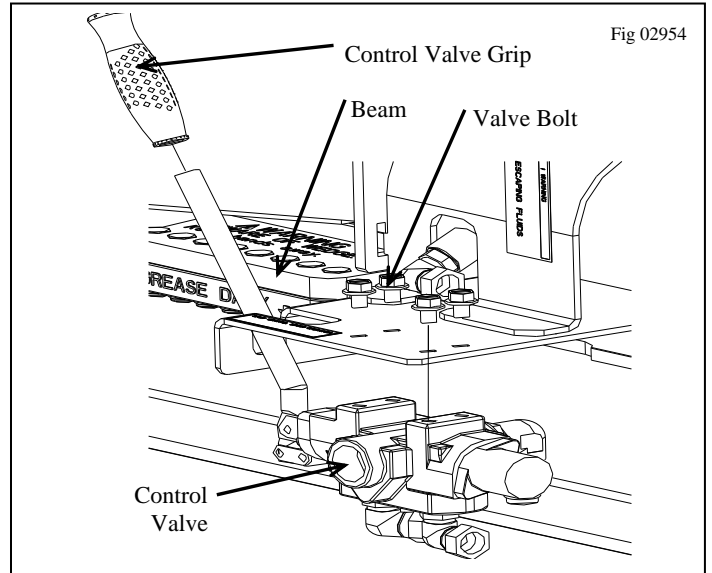

Step 15

- Slightly loosen Hose Clamp on end of the Return Line.
- Slide the Return Line onto the Valve Return Line Fitting
- Tighten Hose Clamp

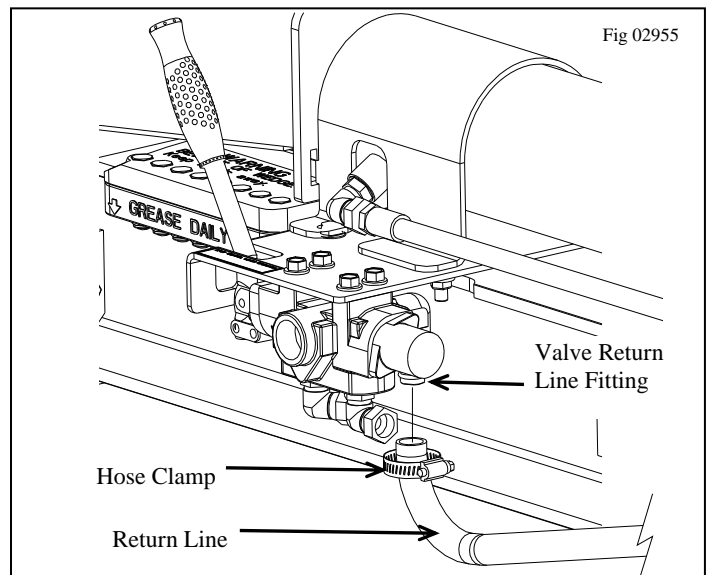

Step 16

- Install loose end of Hydraulic Hose with Blue Mark to the Swivel Fitting in port marked "B."
- Install loose end of Hydraulic Hose with Yellow Mark to the Swivel Fitting in port marked "A."
- Tighten the fitting connection to 47 lb-ft. (No hydraulic sealant required)

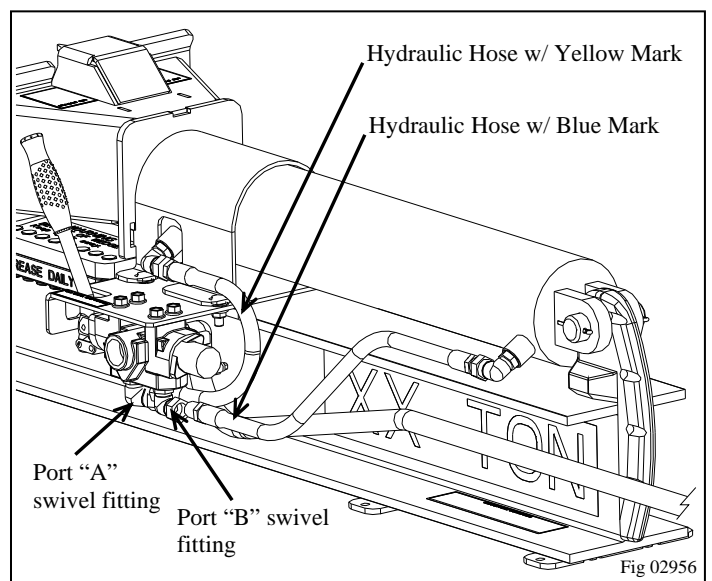

Assembly Instructions

Step 17

- Remove the Plug on the outside of the Control Valve
- Thread the Large Swivel Fitting into the Control Valve
(Tighten the Swivel Fitting finger tight and orient the fitting down as shown, tighten the nut into Control Valve with a wrench to 44-54 lb-ft)

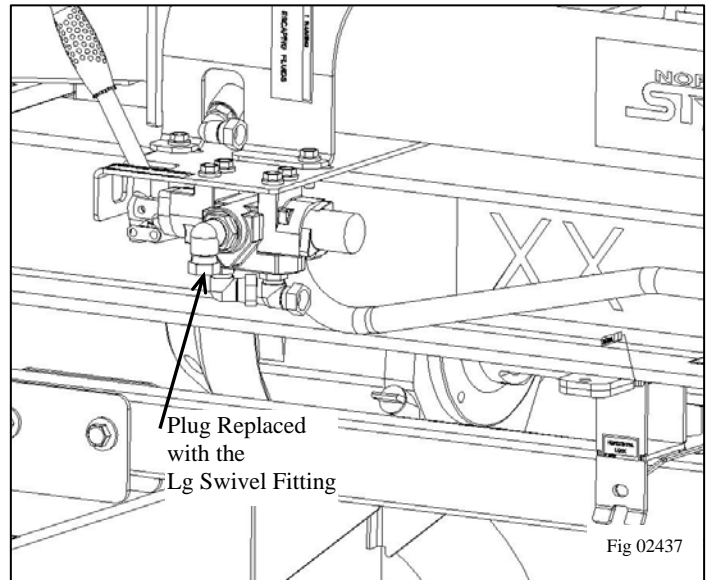

Step 18

- Raise beam to vertical position as described in the SPLITTING OPERATION section of the manual
- Slightly loosen Hose Clamp on to the loose end of the Return line
- Slide the loose end of the Return Line onto the Return Line Fitting
- Tighten Hose Clamp

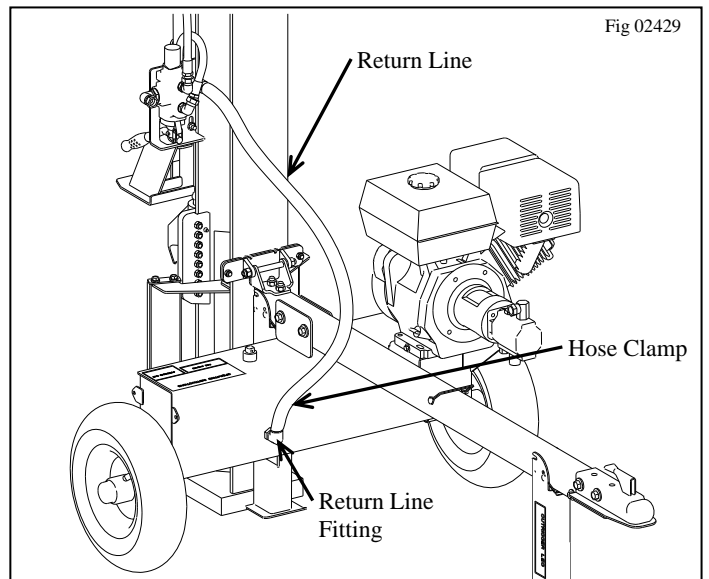

Step 19

- Install loose end of Hydraulic Hose into the Large Swivel Fitting as shown and tighten the fitting connection to 47 lb-ft (No hydraulic sealant required)

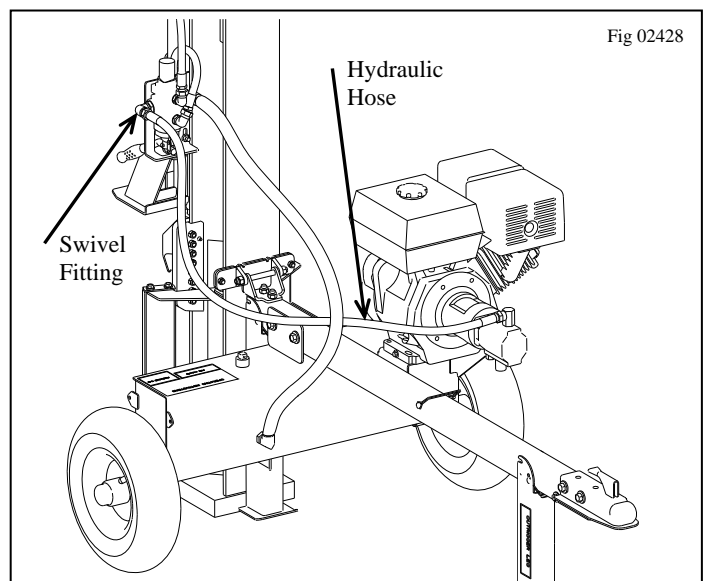

Assembly Instructions

Step 19

- Fill log splitter with hydraulic fluid as outlined in the Initial Unpacking & Set-Up section of the manual.
- Fill engine with SAE 10W-30 as recommended by the engine manufacturer.

Limited Warranty

Dear Valued Customer:

The NorthStar Product you just purchased is built with the finest material and craftsmanship. Use this product properly and enjoy the benefits from its high performance. By purchasing a NorthStar product, you show a desire for quality and durability.

Like all mechanical equipment this unit requires a due amount of care. Treat this unit like the high quality piece of machinery it is. Neglect and improper handling may impair its performance. Please thoroughly read the instructions and understand the operation before using your product.

Limited Warranty

NorthStar shall warranty any piece of equipment manufactured, or parts of equipment manufactured, to be free from defects in material or workmanship for a period of 2 year from the date of purchase by user. This warranty applies to the original purchaser of the equipment and is non transferable. Verification of purchase is the responsibility of the buyer. Parts will be replaced or repaired at no charge, except when the equipment has failed due to lack of proper maintenance. Any misuse, abuse, alteration or improper installation or operations will void warranty. Determining whether a part is to be replaced or repaired is the sole decision of NorthStar.

NOTE: Some services performed by parties other than NorthStar may void warranty.

This warranty covers parts only. It will not provide for replacement of complete products due to defective parts. Components not manufactured by NorthStar such as engines are guaranteed by their manufacturer and can be serviced at factory-authorized locations near you. Any costs incurred due to replacement or repair of items outside of a NorthStar approved facility is the responsibility of the buyer and not covered under warranty. NorthStar can supply you with the service center location in your area.

This warranty specifically excludes the following; failure of parts due to damage caused by accident, fire, flood, windstorm, acts of God, applications not approved by NorthStar in writing, corrosion caused by chemicals, use of replacement parts which do not conform to manufacturer's specifications, and damage caused by vandalism. Additional exclusions: loss of running time, inconvenience, loss of income, or loss of use, including any implied warranty of merchantability of fitness for a specific use.

Warranty does not cover items subject to normal wear such as tires, receptacles or any part subject to direct physical contact by the public. This warranty does not cover any personal injury or damage to surrounding property caused by failure of any part.

This warranty is in lieu of any other warranty expressed or implied and NorthStar assumes no other responsibility or liability outside that expressed within this warranty.

Please fill in the following information and have it on hand when you call in a warranty claim.

Customer Number: _____

Date of Purchase: _____

NorthStar Serial Number: _____

Item Number: _____



Manufactured by
Northern Tool + Equipment Co.,
2800 SouthCross Drive West
P.O. Box 1499 Burnsville, MN 55337-0499