



Pressure Washer A-Frame Hose Reel

Owner's Manual



⚠ WARNING: Read carefully and understand all ASSEMBLY AND OPERATION INSTRUCTIONS before operating. Failure to follow the safety rules and other basic safety precautions may result in serious personal injury.

Items #55791, #55792 & #55793

READ & SAVE THESE INSTRUCTIONS

Thank you very much for choosing a NorthStar™ product!

For future reference, please complete the owner's record below:

Serial Number/Lot Date Code: _____

Purchase Date: _____

Save the receipt, warranty, and this manual. It is important that you read the entire manual to become familiar with this product before you begin using it.

This hose reel is designed for certain applications only. Northern Tool and Equipment is not responsible for issues arising from modification or improper use of this product such as an application for which it was not designed. We strongly recommend that this product not be modified and/or used for any application other than that for which it was designed.

For technical questions, please call **1-800-222-5381**.

Table of Contents

Intended Use.....4

Packaging Contents.....4

Technical Specifications4

Important Safety Information4

Specific Operation Warnings6

Assembly Instructions.....6

Before Each Use.....7

Operating Instructions.....7

After Each Use.....7

Maintenance8

Troubleshooting.....8

Parts Diagram8

Replacement Parts9

Limited Warranty.....10

Intended Use

The NorthStar Pressure Washer A-Frame Hose Reel keeps your hose from tangling or kinking.

Packaging Contents

- ASSY, HUB, FLANGE (1)
- ASSY, CRANK (1)
- BRAKE (1)
- BOLT, M10 (6)
- WASHER, FLAT, M10 (12)
- FRAME, HOSE REEL (1)
- ASSY, LOCK PIN (1)
- BOLT, M8 (1)
- NUT, M10 (6)
- SWIVEL (1)
- PILLOW BLOCK (2)
- BRACKET, BRAKE (1)
- NUT, WING, M8 (1)
- WASHER, M8, SS (1)
- FITTING, 1/2" NPT-MX 3/8" NPT-F (2)

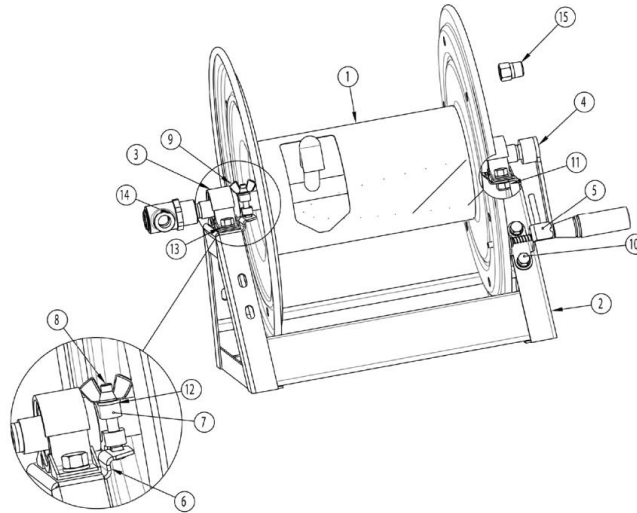

Technical Specifications

Property	Specification
Pressure	5000 PSI
Maximum Temperature	300 F
Shipping Weight	30 lb. (#55791) 32 lb. (#55792 & #55793)
3/8" Hose Capacity #55791	150'
3/8" Hose Capacity #55792	300'
3/8" Hose Capacity #55793	450'
Inlet	1/2" NPT-F
Outlet	1/2" NPT-F

Important Safety Information

⚠️ WARNING

- Read and understand all instructions. Failure to follow all instructions may result in serious injury or property damage.

- The warnings, cautions, and instructions in this manual cannot cover all possible conditions or situations that could occur. Exercise common sense and caution when using this tool. Always be aware of the environment and ensure that the tool is used in a safe and responsible manner.
- Do not allow persons to operate or assemble the product until they have read this manual and have developed a thorough understanding of how it works.
- Do not modify this product in any way. Unauthorized modification may impair the function and/or safety and could affect the life of the product. There are specific applications for which the product was designed.
- Use the right tool for the job. DO NOT attempt to force small equipment to do the work of larger industrial equipment. There are certain applications for which this equipment was designed. This product will be safer and do a better job at the capacity for which it was intended. DO NOT use this equipment for a purpose for which it was not intended.
- Industrial or commercial applications must follow OSHA requirements.

⚠WARNING

WORK AREA SAFETY

- Inspect the work area before each use. Keep work area clean, dry, free of clutter, and well-lit. Cluttered, wet, or dark work areas can result in injury. Using the product in confined work areas may put you dangerously close to cutting tools and rotating parts.
- Do not use the product where there is a risk of causing a fire or an explosion; e.g., in the presence of flammable liquids, gases, or dust. The product can create sparks, which may ignite the flammable liquids, gases, or dust.
- Do not allow the product to come into contact with an electrical source. The tool is not insulated and contact will cause electrical shock.
- Keep children and bystanders away from the work area while operating the tool. Do not allow children to handle the product.

⚠WARNING

PERSONAL SAFETY

- Stay alert, watch what you are doing, and use common sense when operating the tool. Do not use the tool while you are tired or under the influence of drugs, alcohol, or medication. A moment of inattention while operating the tool may result in serious personal injury.
- Dress properly. Do not wear loose clothing, dangling objects, or jewelry. Keep your hair, clothing and gloves away from moving parts. Loose clothes, jewelry, or long hair can be caught in moving parts. Air vents on the tool often cover moving parts and should be avoided.
- Wear the proper personal protective equipment when necessary. Use ANSI Z87.1 compliant safety goggles (not safety glasses) with side shields, or when needed, a face shield. Use a dust mask in dusty work conditions. Also use non-skid safety shoes, hardhat, gloves, dust collection systems, and hearing protection when appropriate. This applies to all persons in the work area.
- Do not overreach. Keep proper footing and balance at all times.

⚠CAUTION

HOSE REEL USE AND CARE

- Do not force the hose reel. Products are safer and do a better job when used in the manner for which they are designed. Plan your work, and use the correct product for the job.
- Check for damaged parts before each use. Carefully check that the hose reel will operate properly and perform its intended function. Replace damaged or worn parts immediately. Never operate the product with a damaged part.
- Store the hose reel when it is not in use. Store it in a dry, secure place out of the reach of children. Inspect the tool for good working condition prior to storage and before re-use.
- Use only accessories that are recommended by the manufacturer for use with your product. Accessories that may be suitable for one product may create a risk of injury when used with another tool. Never use an accessory that has a lower operating speed or operating pressure than the tool itself.

Specific Operation Warnings

⚠WARNING

- Make sure incoming pressure does not exceed the rated pressure.
- Use proper eye protection when assembling and using the hose reel, including ANSI Z87.1 compliant safety goggles.
- Assemble the hose reel on a clean workbench free of debris and moisture.
- Use soap and water when checking for air leaks.
- Keep children away from work area.

Assembly Instructions

⚠WARNING

- Be sure the assembly is securely mounted.

- 1 Connect the handle to either end of the axle.

NOTE: The handle acts as a plug to the flow path so use a suitable thread sealant and tighten accordingly.

- 2 Connect the swivel on the opposite end of the axle as the handle.
- 3 Use 1/2" or 13 mm bolts when securing the hose reel to a ceiling or wall.
- 4 Use thread sealant (not provided) on inlet threads and on outlet hose (not provided).
- 5 Attach the hose reel hose to the hose reel outlet in the hub.

6 Attach the pump hose to the hose reel swivel.

The hose reel is now ready for operation.

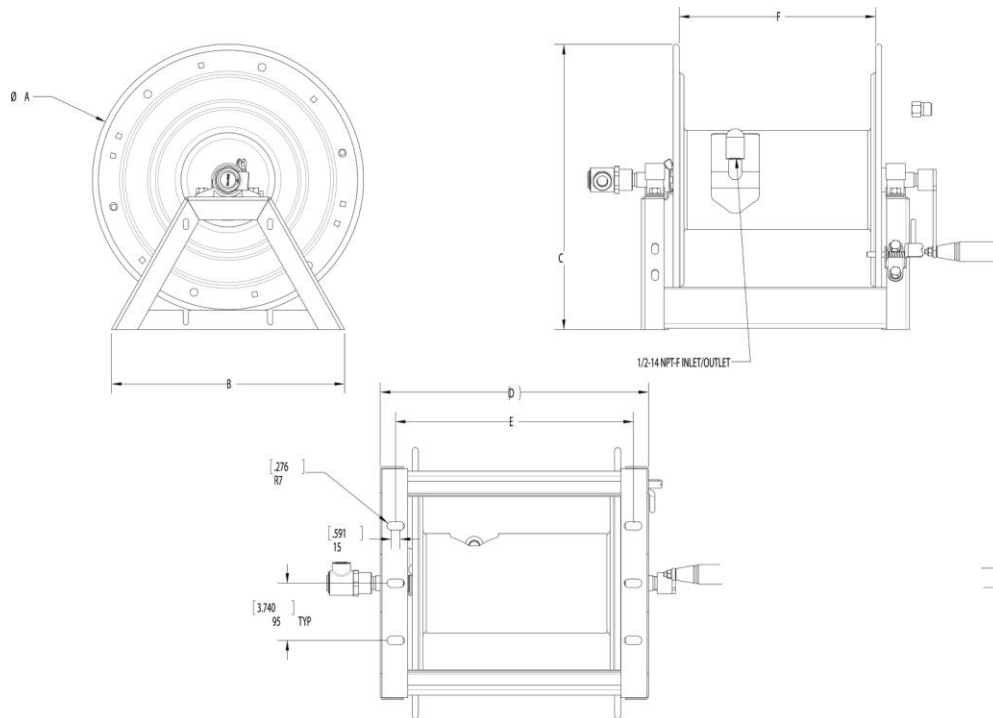

Before Each Use

⚠WARNING

- Be sure all fittings are tight.

Be sure the unit is securely mounted.

Operating Instructions

⚠WARNING

- Do not over pressurize the system. Be sure there are no leaks.

Release the pin lock to unwind the hose. Replace the pin in the lock position after the hose has been rolled out.

After Each Use

⚠WARNING

- Be sure the pin lock is in the locked position, especially if the unit will be moved.

Clean and wipe down your hose reel as necessary

Maintenance

⚠WARNING

- Be sure the system is not pressurized while conducting any maintenance.

Maintain the product by adopting a program of conscientious repair and maintenance in accordance with the following recommended procedures. It is recommended that the general condition of any tool be examined before it is used. Keep your hose reel in good repair.

Troubleshooting

⚠WARNING

- Be sure the system is not pressurized while conducting any maintenance.

Failure	Possible Cause	Corrective Action
Swivel leaks.	normal wear and tear	rebuild swivel
	over pressurization	rebuild swivel

Parts Diagram

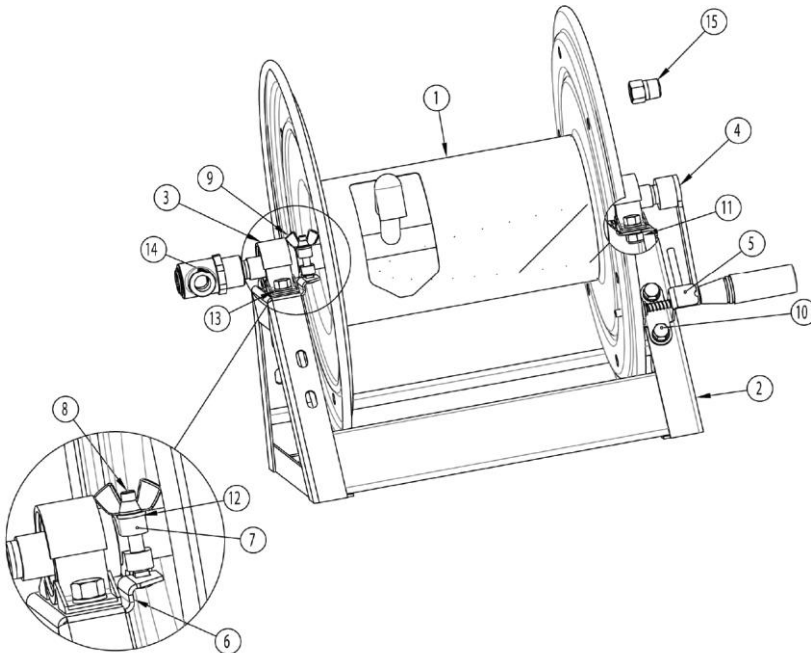

Parts List

Reference	Part Number	Part Description	Quantity
1	2103282	ASSY, HUB & FLANGE, #55793	1
	2103242	ASSY, HUB & FLANGE, #55792	1
	2103247	ASSY, HUB & FLANGE, #55791	1
2	2103283	FRAME, HOSE REEL, #55793	1
	2103243	FRAME, HOSE REEL, #55792	1
	2103248	FRAME, HOSE REEL, #55791	1

Reference	Part Number	Part Description	Quantity
3	2640025	PILLOW BLOCK	2
4	2103244	ASSY, CRANK	1
5	2103245	ASSY, LOCK PIN	1
6	2540087	BRACKET, BRAKE	1
7	2660268	BRAKE	1
8	2200103	BOLT, M8	1
9	2203018	NUT, WING, M8	1
10	2200104	BOLT, M10	6
11	2203017	NUT, M10, NYLOK, SST	5
12	2200013	WASHER, M8, SS	1
13	2203413	WASHER, FLAT, M10	12
14	2103246	SWIVEL	1
15	2530112	FITTING, 1/2NPT-MX3/8NPT-F	2

Replacement Parts

- For replacement parts and technical questions, please call Customer Service at **1-800-222-5381**.
- Not all product components are available for replacement. The illustrations provided are a convenient reference to the location and position of parts in the assembly sequence.
- When ordering parts, the following information will be required: item description, item model number, item serial number/item lot date code, and the replacement part reference number.
- The distributor reserves the rights to make design changes and improvements to product lines and manuals without notice.

Limited Warranty

Northern Tool and Equipment Company, Inc. ("We" or "Us") warrants to the original purchaser only ("You" or "Your") that the NorthStar product purchased will be free from material defects in both materials and workmanship, normal wear and tear excepted, for a period of two years from date of purchase. The foregoing warranty is valid only if the installation and use of the product is strictly in accordance with product instructions. There are no other warranties, express or implied, including the warranty of merchantability or fitness for a particular purpose. If the product does not comply with this limited warranty, Your sole and exclusive remedy is that We will, at our sole option and within a commercially reasonable time, either replace the product or product component without charge to You or refund the purchase price (less shipping). This limited warranty is not transferable.

Limitations on the Warranty

This limited warranty does not cover: (a) normal wear and tear; (b) damage through abuse, neglect, misuse, or as a result of any accident or in any other manner; (c) damage from misapplication, overloading, or improper installation; (d) improper maintenance and repair; and (e) product alteration in any manner by anyone other than Us, with the sole exception of alterations made pursuant to product instructions and in a workmanlike manner.

Obligations of Purchaser

You must retain Your product purchase receipt to verify date of purchase and that You are the original purchaser. To make a warranty claim, contact Us at 1-800-222-5381, identify the product by make and model number, and follow the claim instructions that will be provided. The product and the purchase receipt must be provided to Us in order to process Your warranty claim. Any returned product that is replaced or refunded by Us becomes our property. You will be responsible for return shipping costs or costs related to Your return visit to a retail store.

Remedy Limits

Product replacement or a refund of the purchase price is Your sole remedy under this limited warranty or any other warranty related to the product. We shall not be liable for: service or labor charges or damage to Your property incurred in removing or replacing the product; any damages, including, without limitation, damages to tangible personal property or personal injury, related to Your improper use, installation, or maintenance of the product or product component; or any indirect, incidental or consequential damages of any kind for any reason.

Assumption of Risk

You acknowledge and agree that any use of the product for any purpose other than the specified use(s) stated in the product instructions is at Your own risk.

Governing Law

This limited warranty gives You specific legal rights, and You also may have other rights which vary from state to state. Some states do not allow limitations or exclusions on implied warranties or incidental or consequential damages, so the above limitations may not apply to You. This limited warranty is governed by the laws of the State of Minnesota, without regard to rules pertaining to conflicts of law. The state courts located in Dakota County, Minnesota shall have exclusive jurisdiction for any disputes relating to this warranty.



Distributed by:

Northern Tool & Equipment Company, Inc.

Burnsville, Minnesota 55306

www.northerntool.com

Made in China