



M165926S

ITEM NUMBER: 165926

SERIAL NUMBER: _____

Owner's Manual

Instructions for Installation/Set-up, Operation, Servicing, & Storage Portable, Outdoor Use-Only, Industrial Gasoline Generator 4,500 Watt Continuous (5,500 Watt Surge) Capacity

Can be used to power individual appliances plugged directly into the generator's outlets, or as a back-up connection to a building's power supply (via a professionally installed UL-approved transfer switch).

⚠ WARNING

READ and UNDERSTAND this manual completely before using the generator! Failure to properly set up, operate, and maintain this generator could result in *serious injury or death* from *carbon monoxide poisoning, electric shock, fire/explosion, or burns*. In particular, be aware of the following hazards:

CO Poisoning

Generators give off carbon monoxide, a poisonous gas that can kill you. You CANNOT smell it, see it, or taste it.

- ONLY run generator OUTDOORS and AWAY from building air intakes. NEVER run generator inside any enclosed or semi-enclosed spaces, including homes, basements, garages, sheds, boxes, RVs, boats or pick-up truck beds. These spaces can trap poisonous gases, EVEN if you run a fan or open windows.
- Install carbon monoxide alarms inside nearby structures/buildings (battery-operated, or plug-in with battery backup).

Electric shock / Electrocution

- High voltage electricity from generator can kill. DO NOT operate in wet locations. Be sure generator is properly grounded. Use only UL-listed, outdoor-rated grounded extension cords of proper size.
- NEVER plug the generator directly into a wall outlet. ANY connection to a building's electrical system MUST ISOLATE THE GENERATOR FROM UTILITY POWER via a UL-approved transfer switch installed by a licensed electrician. Otherwise, back feed from the generator into the power grid could kill utility workers.

Fire / Explosion

- DO NOT overload generator (per rated capacity), and OPERATE ONLY in an area with adequate cooling ventilation so engine does not overheat. Exhaust can be extremely hot. Keep muffler at least 7' from all combustible objects.
- All fuels are flammable. Never fuel a running or hot engine. Never pump fuel directly into generator at gas station – use approved container to transfer fuel. Ensure there are no fuel leaks, and keep sources of sparks and flames away.
- ALWAYS keep a fire extinguisher rated "ABC" nearby.

STOP!

CHOOSE THE RIGHT GENERATOR FOR YOUR NEEDS. See the "Power load Planning & Management" section of this manual to determine your power load requirements and then compare to the generator's rated capacity.

INSPECT COMPONENTS: Closely inspect to make sure no components are missing or damaged. See the "Unpacking & Delivery Inspection" section for instructions on whom to contact to report missing or damaged parts.

ARRANGE FOR PROFESSIONAL INSTALLATION of a transfer switch if you will be connecting the generator to your building's electrical system. See the "Installation/Initial Set-Up" section for more information about this requirement.

Any Questions, Comments, Problems, or Parts Orders
Call NorthStar Product Support 1-800-270-0810

Hazard Signal Word Definitions





	<p>This is the safety alert symbol. It is used to alert you to potential personal injury hazards. Obey all safety messages that follow this symbol to avoid possible injury or death.</p>
	<p>DANGER (red) indicates an imminently hazardous situation which, if not avoided, will result in death or serious injury.</p>
	<p>WARNING (orange) indicates a potentially hazardous situation which, if not avoided, could result in death or serious injury.</p>
	<p>CAUTION (yellow) indicates a potentially hazardous situation which, if not avoided, may result in minor or moderate injury.</p>
	<p>CAUTION (yellow) used without the safety alert symbol indicates a potentially hazardous situation which, if not avoided, may result in property damage.</p>

fig01453

Table of Contents

Hazard Signal Word Definitions	2
About Your Generator	4
Specifications	6
Safety Label Locations.....	7
Machine Component Identification.....	8
Power Load Planning & Management.....	11
Installation / Initial Set-Up:	
1. Unpacking & Delivery Inspection.....	13
2. Planning the Power Load.....	13
3. Set-up as a PORTABLE or BUILDING BACK-UP Power Source	14
4. Selecting a Suitable Site	17
5. Grounding the Generator.....	19
6. Battery Installation	20
Operation:	
1. General Safety Rules for Operation	21
2. Preparing for Operation.....	24
3. Starting the Engine	27
4. Checking Generator Output.....	28
5. Connecting Loads.....	29
6. Stopping the Engine	29
7. Storage & Exercise	30
Maintenance & Repair.....	32
Troubleshooting.....	34
Summary of Important Safety Information for Operation.....	35
Generator Exploded View	39
Wiring Diagram.....	41
Generator Head Exploded View	43
Limited Warranty	45

About Your Generator

Thank you for purchasing your NorthStar portable generator!

About Your Generator

This engine-driven, portable generator is designed to provide up to 5500 Watts of electrical power (4500 watts continuous, 5500 watts surge).

It can supply power:

1. As a portable power source. You can plug appliances directly into the generator's electrical outlets.
2. As a back-up, standby power source for a building. A licensed electrician can connect the generator to your building's electrical system via the installation of an **UL-approved transfer switch**. (See the "Installation & Initial Set-up" section of this manual to learn more about specific requirements and precautions relating to wiring the generator to your building's electrical system.)

You must select a generator adequately sized for your power needs. You need to determine the power needs of all the appliances/tools you wish to power at the same time and choose a generator rated to provide at least that power level. See the "Power Load Planning & Management" section of this manual to determine your specific power load requirements and then compare them to this generator's rated capacity. You must not overload the generator. Overloading will cause damage to the generator and attached electrical devices, and may also result in fire.

Be sure to read about site selection and grounding requirements for running this generator. More detailed information can be found in the "Installation & Initial Set-up, Steps 5 & 6" of this manual.

This generator is too heavy for one person to lift without mechanical assistance. An optional wheel kit is available from NorthStar and is recommended if you will be moving the generator unassisted. Other optional accessories available from NorthStar include a cover for storage, UL-approved transfer switches, and extension cords.

Contact NorthStar Product Support at 1-800-270-0810 with questions about optional accessories or to order.

Read this Manual

WARNING

Improper use or maintenance of this generator can result in *serious injury or death* from *carbon monoxide poisoning, electric shock/electrocution, fire/explosion, or burns*.

Read this manual completely before using the generator and follow all instructions and safety rules.

You must follow all instructions and safety precautions presented throughout this manual. A summary of important safety information can be found at the end of the manual. Keep this manual for reference and review.

About Your Generator (cont'd)

Proper preparation, operation, and maintenance will result in operator safety, as well as best performance and long life of the generator. For detailed engine operation and maintenance information, always refer to the engine Owner's Manual furnished with the generator.

NorthStar is constantly improving its products. The specifications outlined herein are subject to change without prior notice or obligation. The purchaser and/or user shall assume liability for any modification and/or alterations of this equipment from original design and manufacture.

Before using, the user shall determine the suitability of this product for its intended use and assumes liability therein.

Contact NorthStar Product Support at 1-800-270-0810 for any questions about the appropriate use of this generator.

Warranty Registration

Please fill out and submit the warranty registration card so that we have your contact information for any future product literature or replacement parts you may need.

ATTENTION:

All Rental Companies and Private Owners who loan this equipment to others!

All persons to whom you rent/loan this generator must have access to and read this manual. Keep this owner's manual with the generator at all times and advise all persons who will operate the machine to read it. You must also provide personal instruction on how to safely operate the generator and remain available to answer any questions a renter/borrower might have.

Specifications

SPECIFICATIONS	
Item Number	#165926
Maximum Output	5500 Watts (W)
Continuous Output	4500 Watts (W)
Voltage	120 / 240 Volt (V)
Phase	Single phase (4-wire)
Frequency	56.5 - 63.3 Hertz (Hz)
Power Factor	1.0 p.f.
Engine	9 HP Honda GX270
Engine Speed	3390 - 3798 RPM
Fuel Type	Unleaded gasoline
Fuel Capacity	6.5 gallons (24.6 L)
Oil Capacity	1.16 US quarts (1.1 L)
Starting Method	Electric Start / Recoil
120 V Receptacle	(1) 20 Amp (A) duplex GFCI (NEMA 5-20R) (1) 20 Amp (A) duplex GFCI Protected (NEMA 5-20R) (1) 30 Amp (A) Locking device (NEMA L5-30R) (1) 50 Amp (A) Straight Blade (NEMA 5-50R)
120/240 V Receptacle	20 Amp (A) Locking device (NEMA L14-20R)
Circuit Breaker	(1) 20 Amp (A) Thermal, push to reset (1) 30 Amp (A) Thermal, push to reset (1) 20 Amp (A) Magnetic, 2 Pole
Grounding Post	Receives 10 Ga. wire or fork terminal
Battery (not included)	12 Volt, Group size U1 170 CCA, 18 amp-hr
Dimensions	
Length	31.75" (80.6 cm)
Width	23.63" (60.0 cm)
Height	22.25" (56.5 cm)
Dry Weight	195 lb. (88.6 kg)
Gross Weight	240 lb. (109 kg)

Safety Label Locations

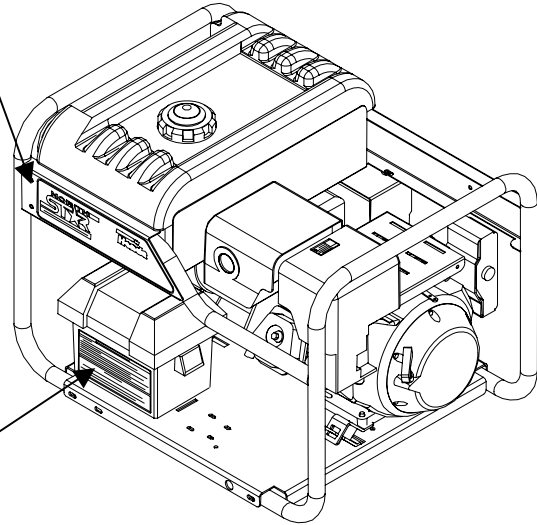
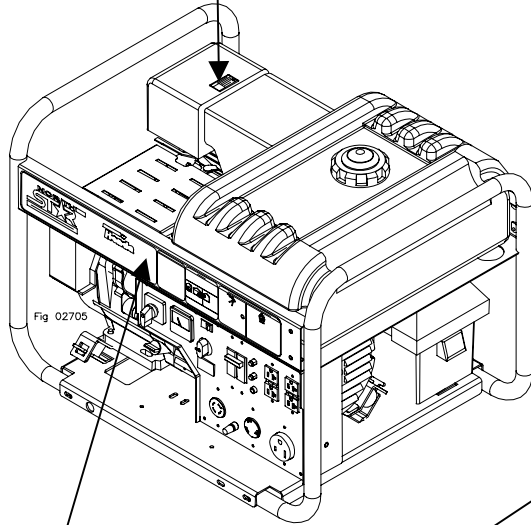
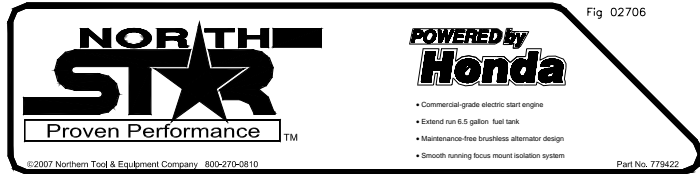

WARNING - BATTERY HAZARDS

BATTERIES:

- 1) contain caustic acid, 2) emit explosive gases, 3) can cause electric shock
- ALWAYS use eye protection. Caustic acid and explosive gases can cause blindness or severe burns.
- NO smoking, sparks, or flames.
- NEVER touch both battery terminals at the same time with your hand or any non-insulated tools.
- FLUSH immediately with water if battery acid contacts eyes, skin, or clothing.
- CONNECT cables in correct sequence: FIRST RED to POSITIVE terminal, then BLACK to NEGATIVE terminal. When disconnecting, DISCONNECT BLACK cable first, then RED.
- NEVER charge a visibly damaged or frozen battery. ALWAYS read and follow charger instructions.

ATTENTION

IF GENERATOR IS TO BE STORED LONGER THAN 2 MONTHS, charge battery with a trickle charger that is rated for 3 amps maximum. A charged battery ensures reliable engine starting.

<p>Commercial-grade electric start engine Extend run 6.5 gallon fuel tank Maintenance-free brushless alternator design Smooth running focus mount isolation system</p>	<p>OPERATING INSTRUCTIONS</p> <ul style="list-style-type: none"> Disconnect all loads to the generator. Turn the generator key switch to the OFF position. After all engine noise subsides turn the fuel shutoff switch to the OFF position or the fuel shutoff valve to the closed position. Turn the key switch to the START position and hold the engine stop. Engine stop is out after 5 seconds wait 10 seconds before attempting to start again. Release the key when the engine starts. When engine starts, move choke lever to the FULL position. Check engine oil level after you restart. 	<p>DANGER</p> <p>Using a generator indoors CAN KILL YOU IN 15 MINUTES.</p> <p>Generator exhaust contains carbon monoxide. It fits in a place you cannot see or smell.</p> <p>NEVER use inside a home or garage. NEVER in tents, boats, and vehicles.</p> <p>Only use OUTSIDE and far away from windows, doors, and vents.</p> <p>Avoid other generator hazards. READ MANUAL BEFORE USE.</p>	<p>WARNING - OPERATING CONDITION HAZARDS</p> <p>Electric Shock/Overcurrent Hazard High voltage electricity from generator can kill.</p> <p>NEVER plug generator directly into a wall outlet. ALWAYS connect to a transfer switch or power distribution system. ALWAYS ISOLATE GENERATOR FROM UTILITY POWER AND ALL OTHER POWER SOURCES.</p> <p>Use only extension cords properly grounded. Use only extension cords with adequate ampacity and length.</p> <p>DO NOT operate in wet locations.</p>	<p>Flammable Hazard Fuel is extremely flammable. Spillage is very hot. Overloading the generator can cause fire.</p> <p>NEVER use generator near flammable liquids, gases, or vapors. NEVER use generator near flammable materials. NEVER use generator near flammable gases. NEVER use generator near flammable dusts. NEVER use generator near flammable fibers. NEVER use generator near flammable liquids. NEVER use generator near flammable gases. NEVER use generator near flammable dusts. NEVER use generator near flammable fibers. NEVER use generator near flammable liquids. NEVER use generator near flammable gases. NEVER use generator near flammable dusts. NEVER use generator near flammable fibers.</p> <p>NEVER use generator near flammable materials. NEVER use generator near flammable gases. NEVER use generator near flammable dusts. NEVER use generator near flammable fibers. NEVER use generator near flammable liquids. NEVER use generator near flammable gases. NEVER use generator near flammable dusts. NEVER use generator near flammable fibers.</p> <p>NEVER use generator near flammable materials. NEVER use generator near flammable gases. NEVER use generator near flammable dusts. NEVER use generator near flammable fibers. NEVER use generator near flammable liquids. NEVER use generator near flammable gases. NEVER use generator near flammable dusts. NEVER use generator near flammable fibers.</p>

Always make sure safety labels are in place and in good condition. If a safety label is missing or not legible, order new labels or unsafe operation could result.

To order replacement safety labels, call NorthStar Product Support at 1-800-270-0810.

On-Product Warning Labels	
Part numbers	Description
39260	Burn Warning
779422	NorthStar
779423	Warning
779396	Battery Warning

Machine Component Identification - Item #165926S

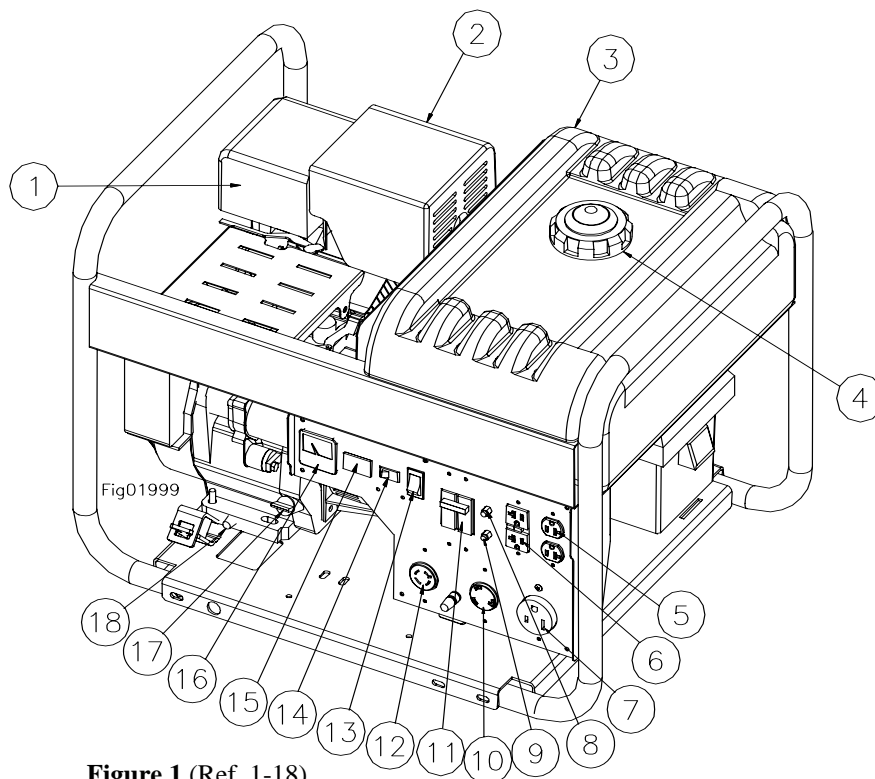

Figure 1 (Ref. 1-18)

Ref.	Description	Ref.	Description
1	Air Cleaner	14	Idle Control On/Off Switch
2	Super Silent Muffler	15	Hour Meter
3	6.5 Gallon Gas Tank	16	Voltmeter
4	Gas Cap with Gauge	17	Engine Oil Fill and Dip Stick
5	120V/20A Duplex Receptacle	18	Engine Oil Fill Drain Plug
6	120V/20A Duplex Receptacle	19	Generator Head
7	120V/50A Straight Blade Receptacle	20	Battery Box
8	20A Circuit Breaker	21	Vibration Isolation Mount
9	30A Circuit Breaker	22	Engine Recoil Rope
10	120V/30A Locking Receptacle	23	Fuel Valve Lever
11	Main Line Circuit Breaker 20A	24	Choke Lever
12	120-240V/20A Locking Receptacle	25	Engine Key Switch
13	Full Power Switch		

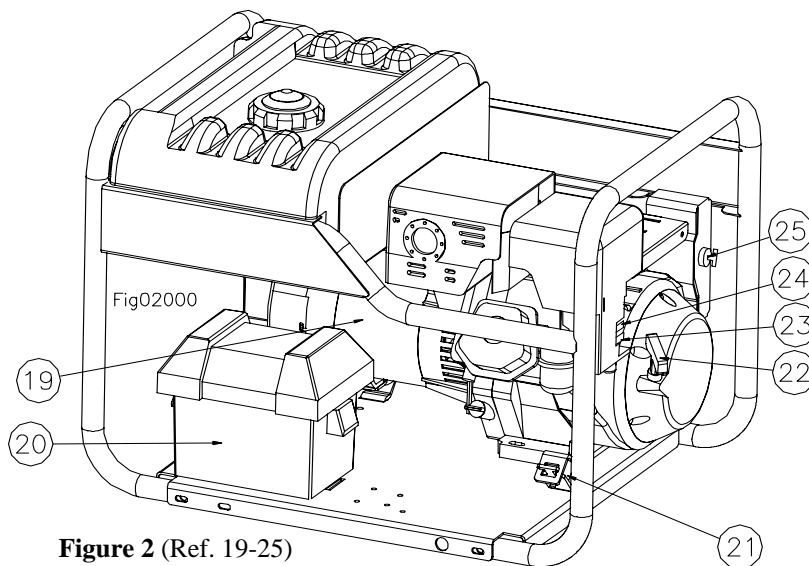

Figure 2 (Ref. 19-25)

Machine Component Identification - Item #165926S

REFERENCE GUIDE	
Reference 1 – Air Cleaner	Refer to your Honda engine manual for air cleaner care
Reference 2 – Super Silent Muffler	8 dB less than Honda's standard muffler.
Reference 3 – 6.5 Gallon Gas Tank	Large tank allows for extended run capabilities. ALWAYS allow room for gasoline expansion by not filling the gas tank completely full.
Reference 4 – Gas Cap with Gauge	The gas cap is extra large, creating a large hole for refilling and a comfortable grip. You can monitor the fuel level without removing the cap by using the fuel level indicator built into the gas cap.
Reference 5 - 120V/20A Duplex Receptacle	One duplex (two receptacles in a common housing) 120V GFCI protected straight-blade receptacles capable of drawing 20 amp, National Electrical Manufacturer's Association (NEMA) part number 5-20R. These receptacles accept NEMA numbers 5-15P or 5-20P plugs.
Reference 6 - 120V/20A Duplex Receptacle	One duplex (two receptacles in a common housing) 120V GFCI straight blade receptacles capable of drawing 20 amps, National Electrical Manufacturers Association (NEMA) number 5-20R. This receptacle accepts a NEMA number 5-15P or 5-20P plug.
Reference 7 - 120V/50A Straight Blade Receptacle	One straight-blade 120V receptacle capable of drawing 50 amp, NEMA 5-50R. This accepts only NEMA 5-50P plugs.
Reference 8 – 20A Circuit Breaker	20 amp push-to-reset circuit breaker
Reference 9 – 30A Circuit Breaker	30 amp push-to-reset circuit breaker
Reference 10 - 120V/30A Locking Receptacle	One locking device 120V receptacle capable of drawing 30 amps, (NEMA) number L5-30R. This receptacle accepts only a NEMA 5-30P plug.
Reference 11 - Main Line Circuit Breaker 20A	20 amp magnetic 2 pole main circuit breaker to protect against electrical overloads. This circuit breaker controls power to all receptacles on the control panel.
Reference 12 - 120-240V/20A Locking Receptacle	One locking device 120/240V receptacle capable of drawing 20 amps, (NEMA) number L14-20R. This receptacle accepts only NEMA 14-20P plugs.
Reference 13 – Full Power Switch	The switch reconnects the two generator windings from 120V only to 120/240V. <ul style="list-style-type: none"> • 120V Only: Allows all 4500 watts (37.5A) to be used in any combination of 120 volt receptacles. The 120/240V receptacle is 120V only. • 120/240V : Allows all 4500 watts to be used for 240V. However, only half the power or 2250 watts (18.8A), can be used at any one 120V receptacle. 120V output can total 4500 watts.
Reference 14 – Idle Control On/Off Switch	This feature senses the load on the generator. With no load on the generator the engine speed drops to idle. This saves fuel and lengthens engine life. When

Machine Component Identification - Item #165926S

	a load is applied, the engine speed returns to 3600 RPM. Turning the switch off disables the sensing device and the generator will run at 3600-3780 RPM whether or not a load is applied.
Reference 15 – Hour Meter	Monitors engine run time to help track maintenance intervals.
Reference 16 – Voltmeter	Voltmeter needle should be in green area during all generator load conditions.
Reference 17 – Engine Oil Fill and Dip Stick	Add or check engine oil after consulting your Honda engine manual.
Reference 18 – Engine Oil Drain Plug	Refer to your Honda engine manual for oil change recommendations.
Reference 19 – Generator Head	The electricity producing part of the generator.
Reference 20 – Battery Box	The battery box provides protection for the battery and will accept a lawn tractor size battery (Group U1-7).
Reference 21 – Vibration Isolation Mount	The engine and generator are mounted on rubber cylinders that absorb most of the engine vibration. This feature eliminates the tendency of the machine to “walk” which is common in engine powered equipment.
Reference 22 – Engine Recoil Rope	Grasp firmly when starting engine.
Reference 23 – Fuel Valve Lever	The ON-OFF valve is mounted on the front of the engine. ALWAYS keep this valve closed when the generator is not in use or being transported.
Reference 24 – Choke Lever	Used during cold starts. Refer to the starting/stopping instructions and the Honda engine manual for usage.
Reference 25 – Engine Key Switch	The engine key is located on the engine. Always locate this switch and be familiar with its location before operating the generator. Consult the Honda engine owner’s manual for further instructions.

Power Load Planning & Management

WARNING

NEVER exceed the rated wattage capacity of your generator.
 OVERLOADING may cause SERIOUS DAMAGE to the generator and attached electrical devices, and may result in fire.

Your generator **MUST BE SIZED PROPERLY** to provide both the running and starting (surge) wattage of the devices you will be powering. Before using your generator, determine the running and starting wattage requirements of all the electrical devices you will be powering simultaneously. The sum of the running and starting wattages of the devices being powered must not exceed the continuous output rating of your generator. (The continuous output rating of your generator is listed in the “Specifications” section of this manual.) Note that:

- Devices without electric motors such as light bulbs, radios, and televisions have the same running and starting wattage.
- Devices with electric motors such as refrigerators, compressors, and hand tools typically require a starting wattage that is 3 to 5 times greater than the running wattage.

The running and starting wattage requirements are often listed on a device’s nameplate. If wattage is not given on the device’s nameplate, the wattage may be calculated by multiplying the nameplate voltage by nameplate amperage, $\text{Watts} = \text{Volts} \times \text{Amps}$.

Example conversion to watts:

$$120 \text{ Volts} \times 5 \text{ Amps} = 600 \text{ Watts}$$

If only the running voltage is given on the nameplate for a device with an electric motor, the starting wattage can be approximated to be three to five times the running wattage.

Estimates for the running wattage requirements for common devices are listed in **Table 1** below. Guidance for starting wattages is provided in the table’s footnotes.

Table 1

Device	Running Watts	Device	Running Watts
Air conditioner (12,000 BTU)	1700 (a,b)	Jet pump	800 (a)
Battery charger (20 Amp)	500	Lawn mower	1200
Belt sander (3")	1000	Light bulb (100 Watt)	100
Chain saw	1200	Microwave oven	700
Circular saw (6½")	2000 (a,b)	Milk cooler	1100 (a)
Coffee maker	1800 (a,b)	Oil burner on furnace	300
Compressor (1 HP)	1400 (a,b)	Oil-fired space heater (140,000 Btu)	400
Compressor (¾ HP)	1800 (a)	Oil-fired space heater (85,000 Btu)	225
Compressor (½ HP)	1400 (a)	Oil-fired space heater (30,000 Btu)	150
Curling iron	700	Oven	4500
Dishwasher	1200	Paint sprayer, Airless (1/3 HP)	600 (a)
Edge trimmer	500	Paint sprayer, Airless (handheld)	150
Electric nail gun	1200	Radio	200
Electric range (1 element)	1500	Refrigerator	600 (b)
Electric skillet	1250	Slow cooker	200

Power Load Planning & Management (cont'd)

Device	Running Watts	Device	Running Watts
Furnace fan (1/3 HP)	1200 (a)	Submersible pump (1-1/2 HP)	2800 (a)
Freezer	800 (b)	Submersible pump (1 HP)	2000 (a)
Hair dryer	1200	Submersible pump (1/2 HP)	1500 (a)
Hand drill (1")	1100	Sump pump	600 (a)
Hand drill (1/2")	875	Table saw	2000 (a)
Hand drill (3/8")	500	Television	500
Hand drill (1/4")	250	Toaster	1000
Hedge trimmer	450	Vacuum cleaner	250
Home computer	150	VCR	70
Impact wrench	500	Water Heater	3000
		Weed trimmer	500

(a) Hard-starting motors require 3-5 times the rated running watts

(b) For extremely hard to start loads such as air conditioners and air compressors, consult the equipment dealer to determine maximum wattage

To calculate the running and starting wattage requirements for the devices you will be powering, follow these steps:

1. Make a list of all electrical devices you will be powering at the same time with the generator.
2. List the greater of the running or starting wattage next to each device as obtained from the devices' nameplate or **Table 1**. If only the running wattage for a device with an electric motor is known, the starting wattage can be estimated to be at least 3 times the running wattage.
3. Add the wattages for all devices on your list. This total must be lower than the continuous output rating of your generator.

Example:

Device to be Powered	Greater of Starting/Running Wattage
Light Bulb	75 W
Refrigerator – 18 Cu. Ft.	1600 W
Microwave	700 W
Window AC	1800 W
Sump pump (1/3 hp)	2100 W
Total	6275W

In this example, the generator must have a continuous output of at least 6275 W in order to power all of the devices simultaneously.

STAGGERING LOADS

You can increase the number of devices your generator can power by staggering the load on the generator. For example, you could alternately power your refrigerator and air conditioner for limited periods of time -- powering only one of the devices at a time and never powering both at the same time.

Installation / Initial Set-Up

There are a number of important steps required to set up your generator for initial use. These steps are:

Steps for Installation / Initial Set-Up

- 1. Unpacking & delivery inspection.**
- 2. Planning the power load to stay within the generator's rated capacity.**
- 3. Setting up generator for the type of power generation you need:**
 - a. portable power source, or**
 - b. connected to a building as a back-up power source.**
- 4. Selecting a site for using the generator.**
- 5. Grounding.**
- 6. Battery installation (electric start models only).**

Each of these steps is discussed in detail below:

1. Unpacking & Delivery Inspection

You should inspect the generator immediately after you receive delivery.

See the "Machine Component Identification" section of this manual for a diagram of the generator and its components.

- If you have *missing* components, contact NorthStar Product Support at 1-800-270-0810.
- If you have *damaged* components, contact the freight company that delivered the unit and file a claim.

2. Planning the Power Load

Plan your power load so that you do not exceed the generator's rated capacity.

See the "Power Load Planning & Management" section of this manual to review how to plan and manage power loads for the generator.

Installation / Initial Set-Up

3. Set-up either as a BUILDING BACK-UP or PORTABLE Power Source

This generator is designed to provide up to 5500W of electrical power. It can supply electricity in two ways:

1. **As a back-up, standby power source for a building.** For this application, you must arrange for a licensed electrician to connect the generator to your building's electrical system via the installation of an UL-approved transfer switch. The transfer switch must be installed in accordance with building electrical code and guidelines supplied by your power company.
2. **As a portable power source.** You can plug appliances or tools directly into the generator's electrical outlets.

Specific requirements for each are given below.

Note: Regardless of whether you use your generator as a back-up power source connected to a building or as a portable power source, you must not overload the generator. Overloading may cause serious damage to the generator and attached electrical devices.

Using as a Back-up Power Source for a Building

Contact a licensed electrician to install a UL-approved transfer switch if you want to use your generator as a back-up power source for a building.

What does a transfer switch do? It:

- a) Safely connects the generator to your building's electrical system by isolating your generator from your utility company's power lines, AND
- b) Connects your generator to a critical subset of your building's circuits that are needed for emergency power needs.

If your generator will be connected to your building's electrical system, it **MUST ALWAYS** be isolated from the utility power grid with a *UL-approved transfer switch installed by a licensed electrician* in compliance with all applicable building and electrical codes, and in accordance with guidelines supplied by your power company.

DANGER:

A transfer switch must be installed in order to isolate your generator from the utility power grid. If your generator is NOT properly isolated from the utility system, serious hazards will arise:

- ◆ When your generator is running, it's output will back feed into the utility power line and transformer that are normally used to provide you with power. The transformer will step up the current to the normal line voltage. An unsuspecting utility line worker working on what he thinks is a deactivated line could be electrocuted.
- ◆ If your generator is connected (running or not) when utility power is restored, your generator will be destroyed. It could also explode or cause fire.

In addition to isolating your generator from the utility system, the transfer switch connects your generator to a limited set of circuits in your building that have been chosen as critical to operate during a power outage.

Installation / Initial Set-Up

The generator cannot power your entire home -- you must work with the installing electrician to determine which devices/appliances you wish to power during an outage. The electrician can help you determine which circuits and devices can be powered simultaneously without overloading the generator.

(See the previous section of this manual entitled “**Power Load Planning & Management**” for more information on load application and selection.)

Using as a Portable Power Source

When using the generator as a portable power source, you can plug electric devices and appliances directly into the generator’s electrical outlets.

There are four different kinds of electrical outlets on the generator:

1. One 120/240 Volt, 20 Amp locking receptacle (NEMA L14-20R locking receptacle compatible with L14-20P mating plug).
2. One 120 Volt, 50 Amp straight-blade receptacle (NEMA 5-50R receptacle compatible with NEMA 5-50P mating plug)
3. One 120 Volt, 30 Amp locking receptacle (NEMA L5-30R receptacle compatible with NEMA L5-30P mating plug)
4. Two 120 Volt, 20 Amp, duplex GFCI-protected straight-blade receptacles (NEMA 5-20R duplex receptacles compatible with NEMA 5-20P or 5-15P mating plugs). Both duplex receptacles share a single trip light and reset button.

Note: This generator is equipped with a Full Power Switch that allows you to switch between 120V only or 120/240V power at the outlets. See the “Machine Component Identification” section of this manual for more information about the use of the Full Power Switch.

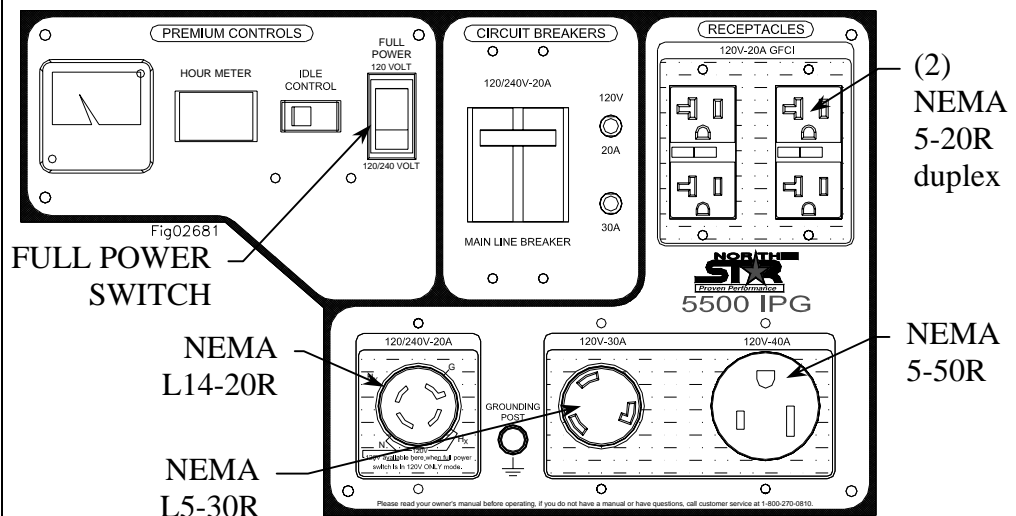

(See more technical detail about these receptacles and their associated circuit breakers in the “Machine Component Identification” section of this manual.)

Installation / Initial Set-Up

- ◆ Make sure you plug each electrical device/appliance into the correct generator outlet based on the device's plug configuration and voltage/amperage rating. Never exceed the amperage rating of an outlet.
- ◆ Extension cords may be used to power devices that are located at a distance from the generator. However, use only UL-listed, outdoor-rated, grounded extension cords of the proper size. Use Table 2 below to choose an adequately sized extension cord according to the amperage of the device being used and the length of the cord.

Table 2

Current/Power		Maximum Extension Cord Length			
Amps at	Load	#10 Ga.	#12 Ga.	#14 Ga.	#16 Ga.
240V	(watts)	Cord	Cord	Cord	Cord
10	2400	250'	150'	100'	75'
20	4800	125'	75'	50'	25'
30	7200	60'	35'	25'	10'
40	9600	30'	15'	10'	*
50	12000	15'	*	*	*



WARNING:

Use of under sized extension cords can cause electric shock, fire, or damage to connected devices.

- ◆ All extension and appliance cords must be in good condition and not worn, bare, frayed, or otherwise damaged.



WARNING:

Use of damaged electric cords can cause electric shock or fire.

Note: If an extension cord becomes hot to the touch, it is overloaded or damaged and must be replaced.

Northern Tool is NOT responsible for damage or injury resulting from customer use of inadequate extension cords.

Installation / Initial Set-Up

4. Select a Suitable Site

Before using the generator, you must select a suitable **OUTDOOR** location for installation and operation. This location should meet all of the criteria listed below.

⚠ WARNING:

You must choose a suitable site for operating your generator to avoid equipment damage and/or injury and possible death from carbon monoxide poisoning, electric shock, or fire. Choose a site that meets all of the criteria specified.

Dry, level surface

The generator should be positioned on a dry, firm, level surface.

Ensure that the generator sits level and will not slide or shift during operation. If applicable, block the generator's wheels to prevent sliding and shifting.

Outdoors only – dangerous carbon monoxide exhaust

⚠ WARNING: Carbon monoxide poisoning hazard

The exhaust from your generator contains carbon monoxide (CO), a poisonous gas that can kill. You cannot smell it, see it, or taste it. *Carbon monoxide exhaust is given off whether you are using gasoline, natural gas, or propane as the fuel source to power the generator.* Follow the directions below for choosing a location to operate your generator in order to avoid carbon monoxide poisoning.



The location you choose to operate the generator must be OUTDOORS and away from all air intakes:

- Never run the generator inside any closed or semi-enclosed spaces (even if outdoors), including homes, garages, basements, sheds, or boxes. *These spaces can trap poisonous gases, even if you run a fan or open windows.*
- Place the generator so that the exhaust fumes will not be directed towards people or building air intakes.
- Ensure that working, battery-operated or battery back-up carbon monoxide alarms are used in any dwelling/structure that is in close proximity to the running generator.
- Note that this generator is NOT designed or approved for use in vehicles or marine applications. Never run the generator inside RVs or other vehicles, on boats, or on pick-up truck beds.

⚠ WARNING:

Never attempt to attach ductwork to the muffler system to allow for installation inside an enclosure. This could cause hot air deflection, heat build-up, and increased exhaust backpressure, resulting in possible exhaust leakage or damage to the generator.

Installation / Initial Set-Up

Adequate cooling ventilation	<p>The generator needs adequate, unobstructed flow of air to allow for proper cooling of engine and generator head.</p> <p> WARNING: Heat build-up from inadequate ventilation can result in fire, posing a serious risk to nearby persons and structures.</p> <ul style="list-style-type: none"> • Situate so there is adequate clearance around generator to allow for cooling airflow so that heat does not build up. • Never place the generator immediately adjacent to a building or other structure – allow at least a 7’ clearance. • Do not run the generator in close proximity to other heat-generating equipment, such as another generator. The combined heat that is generated may raise air temperature in the immediate area and there will not be adequate cooling ventilation. • Do not allow debris to accumulate and block airflow. • Do not operate with a tarp, blanket, or cover surrounding the generator.
No wet conditions	<p>Choose a location where the generator will NOT be exposed to rain, snow, or direct sunlight. Exposure to water can cause electric shock.</p> <p>You <i>may</i> operate the generator under an outdoor, canopy-like structure of heat-resistant material that is open on all sides. Make sure that all parts of canopy are at least 7’ from exhaust, and allow for adequate clearance above generator so that heat does not build up.</p>
Hot exhaust clearance	<p>The exhaust gas from your generator is extremely hot and can cause combustible materials to catch on fire.</p> <ul style="list-style-type: none"> • Make sure your generator’s exhaust system is at least 7 feet from all combustible materials and buildings/structures. • Equip the engine with a spark arrestor if the generator will be used near any ignitable forest, brush, or grassy land. (See the “Specifications” section of this manual to determine if your generator is already equipped.) Make sure you comply with applicable local, state, and federal codes. • Keep a fire extinguisher rated “ABC” nearby. Keep it properly charged and be familiar with its use.
Away from dust/dirt	<p>Do not use the generator in extremely dusty or dirty conditions. Excessive dust and dirt can cause premature failure of the machine.</p>
Hearing protection	<p>Generators can produce noise levels of up to 95 dB in close proximity, which can be dangerous to human hearing with prolonged exposure.</p> <p>Hearing protection may be required for persons working within 15-20 feet of the running generator for an extended period of time.</p> <p> WARNING: Never attempt to attach ductwork to the muffler system to lower noise levels. This could cause hot air deflection, heat build-up, and increased exhaust back-pressure, resulting in possible exhaust leakage or damage to the generator.</p>

Installation / Initial Set-Up

5. Grounding the generator

Always ensure the generator is properly grounded to prevent electrical shock.

You must always ground the generator by the following method when using the generator as a portable electrical source:

- 1) Drive a ¾" or 1" copper pipe or rod into the ground close to the generator. The pipe/rod must penetrate moist earth – the depth required will be dictated by local soil conditions. Consult with an electrician.
- 2) Connect an approved ground clamp to the pipe.
- 3) Run a 10 gauge wire from the clamp to the generator grounding post located on the rear of the generator head.
- 4) Do not connect the generator grounding post to a water pipe or a ground used by a radio system.

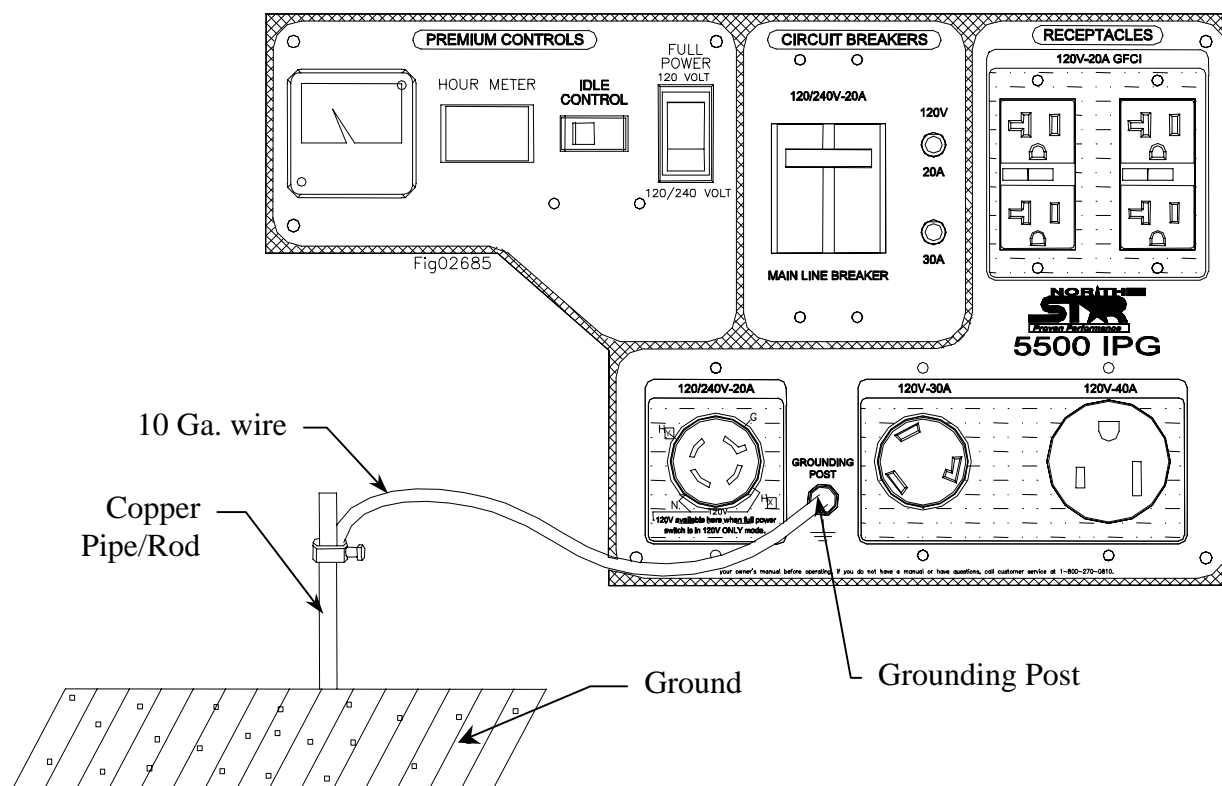

If a licensed electrician installs the generator with a connection to your building's electrical circuit for use as a back-up power system, grounding may alternatively be completed through the building's grounding system. Ask your electrician. If the generator is not grounded through your building's electrical system, follow the procedure above.



WARNING:

Operating the generator when it is not properly grounded can result in electrical shock.

Installation / Initial Set-Up

6. Battery Installation

Your generator's engine is equipped with an electric starter which requires the installation of a 12-volt lawn tractor size battery (Group U1). See the "Specifications" section of this manual for more specific battery requirements for this generator model, such as minimum amperage or CCA rating.

The battery is to be supplied by the customer and should be installed in the protective battery box located near the engine. Follow the instructions detailed below for connecting and disconnecting the battery.

⚠ WARNING: Battery hazards

Batteries are hazardous because they contain caustic acid, can emit explosive gases, and can cause electric shock. Caution must be exercised when making connections to a battery to avoid shock and contact with the acid, and to prevent any sparking that could lead to an explosion.

ALWAYS follow the general battery safety rules and instructions listed below.

General Battery Safety Rules	<ul style="list-style-type: none"> • ALWAYS use eye protection when handling batteries. • NEVER smoke or work near sparks or other sources of ignition. • NEVER touch both battery terminals at the same time with your hand or any non-insulated tools. • If battery acid contacts skin or clothing, flush immediately with water and neutralize with baking soda.
Connecting the battery	<p>Always connect the cables in the following sequence to avoid possible shock:</p> <ol style="list-style-type: none"> 1. Find the battery cables located inside the battery box. 2. Connect the red cable to the positive (+) terminal of the battery. 3. Then connect the black cable to the negative (-) terminal of the battery.
Disconnecting the battery	<p>Always disconnect cables in the following sequence to avoid possible shock.</p> <ol style="list-style-type: none"> 1. First, disconnect the black cable from the negative (-) terminal of the battery. 2. Next, disconnect the red cable from the positive (+) terminal of the battery.

Operation

Once you have set up your generator for use, it is time to start your generator. The following are the procedures necessary for safe, successful operation of your generator.

Operation Procedures

1. **General Safety Rules for Operation**
2. **Preparing for Operation**
3. **Starting the Engine**
4. **Checking Generator Output**
5. **Connecting Electrical Loads (Portable Power Generation)**
6. **Stopping**
7. **Storage & Exercise of Generator**

Each of these procedures is discussed in detail below:

1. General safety rules for operation

Before starting the generator, review the following general safety rules for operation:



WARNING:

Failure to follow safety rules may result in serious injury or death to the operator or bystanders.

- **Know proper use/how to stop.** Be thoroughly familiar with proper use of the equipment and all generator controls, output receptacles, and connections. Know how to stop the generator quickly if needed (see “Operation, Step 6 - Stopping the Engine”).
- **Instruct operators.** The generator owner must instruct all operators in safe generator set-up and operation. Only trained adults should set up and operate the generator – Do not let children operate.
- **Intended use.** Carefully read about and understand the intended use of this generator. Do not use for other purposes, as unforeseen hazards or equipment damage may result.
- **Under the influence.** Never operate, or let anyone else operate, the generator while under the influence of alcohol, drugs, or medication.
- **Safety equipment / controls.** Do not operate the generator unless all safety covers, guards, and barriers are in place and in good working order, and all controls are properly adjusted for safe operation.
- **Damaged.** Do not operate the generator with damaged, missing, or broken parts.
- **Modifications.** Do not modify the generator in any way. Modifications can create serious safety hazards and will also void the warranty.
- **Engine speed.** Never attempt to modify the engine speed setting. The engine speed is preset at 3600 RPM for safe and optimal performance of the generator. If speed needs adjusting, it must be done by factory-authorized personnel.
- **External fuel sources.** Never attempt to connect external gasoline/diesel sources in order to increase engine run time. Larger tank at pressure or higher elevation will cause gasoline to leak from carburetor during operation. Fire or explosion could result.

Operation (cont'd)

- **Malfunction during operation.** Immediately turn off the generator if any of the following conditions arise during operation:
 - Excessive change in engine speed, slow or fast
 - Overheating in load connecting devices
 - Sparking or arcs from generator
 - Loss of electrical output
 - Receptacle damage
 - Engine misfire
 - Excessive vibration
 - Flame or smoke
 - Abnormal noise
- **Adjusting / repairing.** Always turn off generator and remove spark plug(s) or spark plug wire(s) before working on the generator to prevent accidental starting. Always discharge the capacitor before working on the generator head to prevent electrical shock. (See Maintenance & Repair section of this manual for instructions on how to do this.)
- **Carbon monoxide poisoning.** The running engine gives off carbon monoxide, a poisonous gas that can kill you. You CANNOT smell it, see it, or taste it. Follow all instructions for site selection and positioning the generator, and avoid inhaling the exhaust. If you start to feel sick, dizzy, or weak while using the generator, shut off the engine and get to fresh air RIGHT AWAY. See a doctor. You may have carbon monoxide poisoning.
- **Other exhaust dangers.** This product contains or emits chemicals known to the State of California to cause cancer, birth defects or other reproductive harm. Avoid inhalation of exhaust.
- **Wet conditions.** Do not operate the generator or handle any electrical equipment while standing in water, while barefoot, while hands are wet or while in the rain or snow. Electric shock may result.
- **Ground fault circuit interrupter.** Always use a ground fault circuit interrupter (GFCI) protected extension cord (or outlet, if generator is equipped) in damp or highly electrical conductive areas and on construction jobsites to prevent electrical shock.
- **Avoid contact.** Avoid contact with bare wires, terminals, connections, etc. while the unit is running.
- **Electric shock accident.** If an electric shock accident occurs, immediately shut down the source of electrical power. If this is not possible, attempt to free the victim from the live conductor. Avoid direct contact with victim. Use a nonconducting implement, such as a dry rope or board, to free the victim from the live conductor. Apply first aid and get immediate medical help.
- **Smoking/sparks.** Never smoke near the running generator, and never operate near sources of sparks or flames.
- **Hot muffler.** Never touch hot muffler, hot exhaust manifold, or engine cooling fins. Exhaust and engine parts can be very hot and will burn you.
- **Moving parts.** Keep hands, feet, and apparel away from drive belts, fans, and other moving parts. Never remove any drive belt or fan guard while the unit is operating.

Operation (cont'd)

Static electricity and filling the gasoline tank:

Static electricity can initiate from ungrounded gasoline tanks or containers, from flowing gasoline, and from persons carrying a static electric charge

Static electricity can explosively ignite gasoline vapors that are present during the fueling process, resulting in serious burns to nearby persons. To avoid static electricity while fueling, certain steps must be followed before and during the fueling process in order to minimize and safely dissipate static charge build-up:

- ***Touch a grounded metal object before starting.*** Always dissipate static charge from your body before beginning the fueling process by touching a grounded metal object at a safe distance away from fuel sources.
- ***Use a portable container to fill tank.*** Never fill the generator's gas tank directly from the fuel pump – the generator's tank is not grounded and the high velocity flow of gasoline from a fuel pump can cause static electric build-up. Use an approved portable container to transfer gasoline to the generator's tank.
- ***Fill container on the ground.*** Never fill the portable gas container while it is sitting inside a vehicle, trailer, trunk, or pick-up truck bed. ALWAYS place container on the ground to be filled.
- ***Keep nozzle in contact with container.*** Keep nozzle in contact with the portable container at all times while filling. Manually control the flow of gasoline; do NOT use the nozzle's lock-open device.
- ***Use a portable container made of metal or conductive plastic.*** It will dissipate charge to ground more readily.

About static electricity and fueling

Many common objects can accumulate and retain a static electric charge. Objects made of non-conductive materials (e.g. plastics) easily accumulate and retain static electric charge, as can objects made of conductive material (e.g. metal, water) if they are not electrically grounded. The static electric charge on an object, such as a human body or plastic fuel tank/container, can reach as high as several thousand volts!

A static electric spark can be generated if the static electric charge stored on an object "jumps" to another, less charged object. Such a spark can ignite invisible gasoline vapors that are present during fueling situations.

Typical sources of static electric hazards during fueling

The following objects can accumulate a static electric charge and cause an ignition spark in typical fueling situations:

- 1) **Ungrounded tanks/containers.** Any ungrounded fuel tank or container can accumulate a static electric charge as a result of contact with other objects or friction during transportation. This static electricity can discharge as a spark to the grounded gasoline dispenser nozzle, as the nozzle is first brought close to the tank/container at the beginning of the fueling process.
- 2) **Flowing gasoline.** Most people are not aware that gasoline accumulates static electric charge while flowing through a hose or pipe. This charge then transfers to and accumulates in the gas tank or container that is being filled. The total amount of charge accumulation depends on the amount of gas pumped into the container, the speed with which it is pumped, and whether or not the tank/container is grounded. If sufficient static electric charge accumulates in the fuel tank or container during the fueling process, the tank/container may discharge a spark to the grounded gasoline dispenser nozzle.
- 3) **Persons.** A person dispensing the gasoline can carry a static electric charge on their body, typically resulting from contact with their car seat or electronics. The static electricity can discharge as a spark between that person's hand and either the grounded dispenser nozzle or the fuel tank opening.

Operation (cont'd)

2. Preparing for Operation	
Position generator	<p>Position generator in accordance with the instructions given in “Installation & Initial Set-up, Step 4: Select a Suitable Site” of this manual.</p> <p>Operate outside only, on dry, level ground with adequate clearance and ventilation.</p> <p>⚠ WARNING: Carbon monoxide poisoning hazard Generators give off carbon monoxide exhaust, a poisonous gas that can kill. You CANNOT smell it, see it, or taste it. ONLY run generator OUTDOORS and away from air intakes. NEVER run generator inside any enclosed or semi-enclosed spaces, including homes, garages, basements, sheds, boxes, pick-up truck beds, RVs, or boats. These spaces can trap poisonous gases, EVEN if you run a fan or open windows. <i>Carbon monoxide exhaust is given off whether you are using gasoline, natural gas, or propane to power the generator.</i></p>
Ground generator	<p>Make sure the generator is grounded in accordance with instruction given in “Installation & Initial Set-up, Step 5: Grounding the Generator” of this manual.</p> <p>⚠ WARNING: Electric shock hazard Always ensure generator is properly grounded to prevent electrical shock.</p>
Perform scheduled maintenance as needed	<p>Make sure that any regular maintenance has been performed as prescribed in this manual in the “Maintenance & Repair” section.</p> <ol style="list-style-type: none"> 1. Refer to the engine owner’s manual for engine maintenance instructions. 2. Make sure battery is charged. Charge as needed according to your battery manufacturer’s instructions.
Check/add oil	<p>Check the oil level using the dipstick and add oil as needed.</p> <p>Using a funnel, add oil up to the FULL mark on the dip stick with the recommended oil type for your engine and expected ambient conditions. (See engine Owner’s Manual for oil type and capacity, and more detailed oil check/fill instructions.)</p> <p>⚠ WARNING: Burn hazard Never open oil port while engine is running. Hot oil can spray over face and body.</p> <p><i>Notes:</i></p> <ul style="list-style-type: none"> ○ <i>Low oil shutdown feature prevents the generator from starting without sufficient oil.</i> ○ <i>Engine is shipped <u>without</u> oil. You must add oil before first use.</i> <p>IMPORTANT: Under long, continuous-run operating conditions, be prepared to:</p> <ul style="list-style-type: none"> • Check engine oil level every time you refuel the engine. • Change oil after the first 20 operating hours, and at least every 100 operating hours thereafter, or as directed in engine owner’s manual.
Check/fill gasoline tank	<p>Check the gasoline level in the generator’s tank. If needed, fill tank with fresh unleaded gasoline from a portable container, after first reading the warnings and instructions below.</p>

Operation (cont'd)

WARNING: Gasoline fire/explosion hazard

Gasoline is highly flammable and explosive. Heat, sparks, and flames can ignite gasoline vapors, which can become widespread during fueling. A flash fire and/or explosion could result and cause serious injury or death. Use extreme care when handling gasoline. Carefully follow all the instructions in this section to avoid the following conditions which could result in gasoline ignition:

- gas vapor collection inside enclosures
- static electric sparks
- sparks from electric wiring, batteries, or running engines
- sources of heat (such as a hot engine or exhaust)
- open flames, including pilot lights

- 1) Before starting, review the following general safety precautions for fueling:
 - a) Never pump gasoline directly into the generator's gas tank at a gas station – high velocity flow from the pump could result in a static electric build-up in the generator's tank. Always use a portable container to fill the tank. *See warning box about static electric spark hazards below.*
 - b) Fill gasoline tank **OUTDOORS** – never indoors.
 - c) Stay away from all sources of heat, sparks, and flames. Do not smoke.
- 2) Turn generator engine off and allow to cool for at least two minutes before removing gas cap.

Note: A running or still-hot engine is hot enough to ignite fuel.
- 3) Remove generator gasoline cap.
- 4) Add gasoline through the fill opening:
 - Use only a UL-approved portable gasoline container to transfer the gasoline to the generator's tank. Follow the safety warning and instructions below for avoiding static electric sparking.
 - Do NOT overfill the gasoline tank. Allow at least 1/2" of empty space below the fill neck to allow for fuel expansion.

WARNING: Static electric spark hazard

A static electric spark can explosively ignite gasoline vapor, resulting in a flash fire that could cause serious injury or death.

To avoid static electric sparking while filling the gasoline tank, **the following steps must be followed to minimize and safely dissipate static electric charge build-up before and during the fueling process:**

- Always dissipate static charge from your body before beginning the fueling process by touching a grounded metal object at a safe distance from fuel sources.
- Never fill the generator's gas tank directly from the fuel pump – the generator's tank is not grounded and high velocity flow from the pump can cause static electricity build-up. Use an approved portable container to transfer gas to the generator's tank.
- Never fill the portable gas container while it is sitting inside a vehicle, trailer, trunk, or pick-up truck bed. **ALWAYS** place container on the ground to be filled.

Operation (cont'd)

	<ul style="list-style-type: none"> • Keep nozzle in contact with portable container while filling. Manually control the flow of gasoline; do NOT use the nozzle's lock-open device. • A portable container made of metal or conductive plastic is preferred because it dissipates charge to ground more readily. <p>5) Clean up gasoline spills /splashes immediately.</p> <ul style="list-style-type: none"> • If possible, move the generator away from spilled gasoline on the ground. • Wipe up spilled gasoline, and wait 5 minutes for excess gasoline to evaporate before starting engine. • Gasoline soaked rags are flammable and should be disposed of properly. • If gasoline is spilled on your skin or clothes, change clothes and wash skin immediately. <p>6) Replace gasoline cap securely before starting engine.</p> <p>7) Store extra gasoline in a cool, dry place in an UL-approved, tightly sealed container.</p> <p>IMPORTANT: For continuous operation, be prepared to check and refuel the engine on a regular basis. A tank of gasoline should last about 4 hours under 100% load, and about 8 hours under 50% load.</p>
<p>Inspect Fuel System / Check for Leaks</p>	<p>Inspect fuel system & check for leaks BEFORE starting generator. Do not start generator until all needed repairs have been completed.</p> <p> WARNING: Fuel leak hazard Gasoline is highly explosive and fuel leaks can result in fire or explosions. You can be burned and seriously injured if the fuel system is not properly hooked up or there is a fuel leak when you start the engine.</p> <p>Inspect the entire fuel system. <i>Look for:</i></p> <ul style="list-style-type: none"> • signs of leaks or deterioration, • chafed or spongy fuel hose, • loose connections, • loose or missing fuel hose clamps, • a damaged gasoline tank, or a defective gasoline shut-off valve.
<p>Personal Protection</p>	<p>1) Hearing can be damaged from prolonged, close-range exposure to the type of noise produced by this generator. The use of ear plugs or other hearing protection device is recommended for persons working within 15-20 feet of the running generator for an extended period of time.</p> <p>2) Loose or dangling apparel can become entangled in moving parts. Metal jewelry can conduct electricity. Never wear jewelry or loose-fitting clothing when starting or operating the generator.</p>

Operation (cont'd)

3. Starting the Engine

After you have completed the pre-start checklist procedures, you are ready to start the engine.

To start the engine:

- 1) Disconnect all loads to the generator.
- 2) Turn the gasoline line valve to the ON position.
- 3) For cold engine, move choke lever to full choke position. To restart a warm engine, move choke lever to half choke or to RUN position.
- 4) Start the engine:
 - a) Using electric start –
 - i) Turn the engine key switch to the START position and hold it there until the engine starts.

NOTE: If the engine fails to start after 5 seconds, release key and wait 10 seconds before attempting to start again. Cranking the electric starter for more than 5 seconds continuously can overheat and damage the starter motor.
 - ii) Release the key when the engine starts.
 - b) Using recoil start –
 - i) Turn the engine key switch to the ON position.
 - ii) Pull the starter grip lightly until you feel resistance, then pull the starter cord out briskly and rapidly.
 - iii) Allow starter cord to return slowly.
- 5) When engine starts, move choke lever to RUN position.
- 6) Under long, continuous-run operating conditions, be prepared to:
 - a) Check and refuel the engine on a regular basis. A tank of gas should last about 4 hours under 100% load, and about 8 hours under 50% load. See engine owner's manual for more detail.

WARNING:

A running engine is hot enough to ignite fuel. Never add fuel or remove gas cap if engine is running or still hot. Let cool at least 2 minutes.

- b) Check engine oil level each time you refuel.
- c) Change oil after the first 20 operating hours, and at least every 100 operating hours thereafter, as directed in the engine owner's manual.

WARNING:

Never open oil port while engine is running. Hot oil can spray over face and body.

Operation (cont'd)

4. Checking Generator Output

Although the speed of the engine was carefully adjusted at the factory so that the generator produces the proper voltage and frequency, **output voltage should be checked periodically to ensure the generator is working properly before connecting loads to the generator.**



WARNING:

The generator must be run at the correct speed in order to produce the proper electrical voltage and frequency. Failure to do so could result in damage to equipment powered by the generator and possible injury to the individual.

Output voltage should be checked with a portable voltage meter:

1. Start engine and allow to warm up for five minutes. Do not connect any loads.
2. Use the generator's voltage meter to check output voltage.
3. The voltmeter's needle should be within the green area initially and during all load conditions.
4. If measured voltage is not within the specified range, have generator adjusted by factory authorized personnel. Do not attempt to adjust the engine speed yourself.

NOTE:

Slight variation in voltage/speed with changing electrical loads

All engines have a tendency to slow down when a load is applied. When electrical loads are connected to the generator, the engine is more heavily loaded and as a result the speed drops slightly.

This slight decrease in speed, together with the voltage drop within the generator itself, results in a slightly lower voltage when the generator is loaded to its full capacity than when it is running with no load.

Additionally, there may be small brief surges and drops in voltage as motors connected to the generator cycle on or off.

The slight variation has no appreciable effect in the operation of motors, lights, and most appliances.

Operation (cont'd)

5. Connecting Loads

You will want to be careful when connecting loads so as not to overload the generator, especially if you are powering devices with motors that require a higher starting power load.

Instructions are provided below for connecting loads when you are using the generator:

- As a portable power source
- Connected to a building as a back-up power source

⚠ WARNING:

Do not overload generator. Make sure that combined starting and running loads do not exceed rated capacity of generator. Overloading the generator can cause damage to the generator and attached electrical devices, and may result in fire.

Using as a Portable Power Source

Connect electrical loads one at a time according to the following instructions:

1. Allow engine to reach operating speed by allowing it to warm up for approximately 5 minutes before connecting electrical devices.
2. After engine is warmed up, begin by connecting the items that require the highest wattage first. The recommended sequence is as follows:
 - a. Connect items with motors such as refrigerators, freezers, air conditioners, or small hand tools, one at a time. Let each motor stabilize before connecting the next device.
 - b. Connect any lights you are planning on powering.
 - c. Connect voltage sensitive equipment such as electronics via surge protectors. Plug devices such as TV's, computers, and microwaves into a UL listed voltage surge protector, then plug the surge protector into the generator.

Using as a Back-up Power Source for a Building

Each transfer switch installation will be unique.

Proper instructions for how to safely bring the generator online with the building's electrical system should be provided by the installing electrician, who should also provide personal instruction to the owner/operator.

Failure to follow the proper procedure as provided by the electrician could expose persons to the hazards noted above.

6. Stopping

Stop the engine using the following steps:

1. Disconnect all loads to the generator.
2. Turn engine key switch to OFF position.
3. Turn gasoline line shut-off valve to OFF position.
4. Remove key from starter to prevent accidental starting of engine.

Operation (cont'd)

7. Storage & Exercise

When you are finished using the generator, you must:

- Disconnect all loads
- Shut off fuel supply
- Store the generator properly
- Plan on exercising the engine regularly unless the generator is prepared for long-term storage.

Detailed instructions are provided below.

Disconnect loads & turn off fuel supply	<p>When you are finished using the generator, disconnect all loads and turn off fuel supply:</p> <ol style="list-style-type: none"> 1. Make sure all devices that were connected to the generator's outlets have been disconnected. 2. Check to be sure gasoline line shut-off valve is in OFF position.
Cool engine before storing	<p>Let engine cool for at least five minutes before storing. A hot engine can be a fire hazard.</p>
Choose a storage location	<p>Store the generator in a location that is:</p> <ul style="list-style-type: none"> ○ Clean and dry ○ Away from sources of heat, open flames, sparks, or pilot lights, even if the generator's fuel tank is empty. Residual fuel in the tank could ignite. ○ Away from extreme high or low temperatures. <p><u>Note:</u> Do not store with battery charger always connected. Batteries that are over-charged can boil themselves dry and produce excessive amounts of hydrogen, an explosive gas.</p>
Prevent accidental starting	<p>Remove key from starter (for electric start engines) and secure key in a safe location, or remove spark plug(s) in order to ensure the generator cannot be started accidentally in a storage location or by untrained persons.</p>
Exercise generator every 4 weeks	<p>The generator should be exercised regularly.</p> <p>At least every four weeks, start the engine and let it run for 10 to 15 minutes with a small load plugged in, such as a lamp or fan.</p> <p>Monthly exercising of the generator will:</p> <ul style="list-style-type: none"> ○ Dry out any moisture that has accumulated in the windings. If left, this moisture can cause corrosion in the winding. ○ Ensure that the unit is operating properly should it be needed in an emergency.
Perform regular maintenance	<p>Perform periodic maintenance as directed in this manual to keep the generator in safe working condition.</p>

Operation (cont'd)

Prepare engine for long term storage if needed	If you will not be able to exercise the generator regularly, you must prepare the engine for long term storage to prevent gum deposits from forming and causing malfunction of the engine.
	Prepare engine for long term storage by: <ul style="list-style-type: none">○ Removing all gasoline from the tank and carburetor<li style="text-align: center;"><u>OR</u>○ Adding fuel stabilizer to the gasoline (following manufacturer's instructions)
	<p style="text-align: center;"><u>Fuel stabilizer steps:</u></p> <ol style="list-style-type: none">1. Ensure gasoline tank is full.2. Add fuel stabilizer to fuel tank.3. Run engine at least 10 minutes after adding stabilizer to allow it to enter the fuel system.4. Shut off engine5. Disconnect spark plug wire and remove spark plug6. Add one teaspoon oil through spark plug hole7. Place rag over spark plug hole and turn starter (or pull the recoil) a few times to lubricate the combustion chamber.8. Replace spark plug, but do not reconnect the spark plug wire.

Maintenance & Repair

Inspect and maintain your generator as specified below in order to keep it in safe and optimal working order. Follow all safety rules and recommended maintenance steps.

WARNING

ALWAYS shut off the engine, disconnect the spark plug(s) and discharge the capacitor before cleaning, adjusting, or servicing the generator. Make sure all guards and shields are replaced before using.

Note: The generator head is brushless and maintenance free. The bearing is a heavy-duty sealed ball bearing, which requires no maintenance or lubrication.

Maintenance & Repair	
Follow safety rules	<p>Read and follow these safety rules whenever you will be servicing the generator:</p> <ul style="list-style-type: none"> • Turn off generator. Always turn off generator and remove spark plug(s) or spark plug wire(s) before working on the engine or generator to prevent accidental starting. • Discharge capacitor. When the generator is shut down, the capacitor may maintain a charge. Always discharge the capacitor before working on the generator head to prevent electrical shock. Discharge using a screwdriver with an insulated handle. While wearing safety glasses, touch opposite terminals of the capacitor together with the tip of the screwdriver. If there is stored charge in the capacitor, a spark will be generated thereby discharging the capacitor. • Replace guards. Make sure all guards and shields are replaced after servicing the generator. • Repair. Major service, including the installation or replacement of parts, should be performed only by a qualified electrical service technician. Obtain factory approved parts from NorthStar Product Support at 1-800-270-0810. • Replacement parts. If a part needs replacement, only use factory approved repair parts. Replacement parts that do not meet specifications may result in a safety hazard or poor operation of the generator and will void the warranty.
Perform engine maintenance	<p>Perform engine maintenance as specified in the engine owner's manual.</p> <p>Engine maintenance items include:</p> <ol style="list-style-type: none"> 1. Changing oil and oil filter 2. Air filter check/replacement 3. Spark plug cleaning and replacement 4. Fuel filter check/replacement 5. Fuel tank cleaning.
Check receptacles	<p>Check receptacles before each use to make sure they are not cracked or broken.</p> <p>If a receptacle is cracked or otherwise damaged, do not use until replaced with an authorized factory part. Using cracked or damaged receptacles can be both dangerous to the operator and destructive to the equipment.</p>
Inspect fuel system / check for leaks	<p>Inspect the fuel system and check for leaks on a regular basis.</p> <p>Inspect the entire fuel system. Look for: signs of leaks or deterioration, chafed or spongy fuel hose, loose connections, loose or missing fuel hose clamps, damaged gasoline tank, or defective gasoline shut-off valve.</p>

Maintenance & Repair (cont'd)

Check GFCI (if equipped)	<p>Once a month, test the Ground Fault Circuit Interrupter (GFCI) to protect against electrical shock due to failure of the GFCI. (Only for those models equipped with GFCI – See the “Specifications” section.)</p> <p><u>To test the GFCI:</u></p> <ol style="list-style-type: none"> 1. Depress the TEST button. The RESET button should extend from the receptacle. If the RESET button does not extend, contact NorthStar for replacement parts. 2. Restore power to the GFCI by firmly pressing the RESET button back into the receptacle until an audible click is heard.
Clean & inspect spark arrestor (if equipped)	<p>Clean and inspect the spark arrestor muffler. (Only for those models equipped with a spark arrestor – See the “Specifications” section.)</p> <p>If the engine is equipped with a spark arrestor muffler, clean and inspect it regularly (follow manufacturer’s service instructions). Replace if damaged.</p>
Keep generator clean	<p>Keep generator clean.</p> <p>If dust or debris accumulates on the generator, clean the generator with a damp cloth or soft bristle brush. Do not allow air intakes to become blocked.</p> <p><u>Note:</u> Do not spray generator with a garden hose or pressure washer. Water may enter the generator and cause damage to the rotor, stator, or internal windings.</p>
Recharge and maintain battery (if electric start)	<p>Inspect, recharge, and maintain your battery according to your battery manufacturer’s instructions. (Only for those models equipped with electric start.)</p> <p>Do not store with battery charger always connected. Batteries that are over-charged can boil themselves dry and produce excessive amounts of hydrogen, an explosive gas.</p>

IMPORTANT:

If a part needs replacement, only use parts that meet the manufacturer’s specifications. Replacement parts that do not meet specifications may result in a safety hazard or poor operation of the generator.

**Contact NorthStar Product Support at 1-800-270-0810
For any questions, problems, or parts orders.**

Troubleshooting

<i>TROUBLESHOOTING</i>		
<u>Problem</u>	<u>Possible Causes</u>	<u>Possible Remedies</u>
Engine will not start.	<ul style="list-style-type: none"> a) Low oil level. b) Fouled spark plug. c) Out of fuel. d) Stop switch in OFF position. e) Battery has lost its charge. 	<ul style="list-style-type: none"> a) Fill crankcase to proper oil level. b) Clean or replace spark plug. c) Fill fuel tank. d) Place switch in ON position. e) Battery has low electrolyte and/or needs to be charged or replaced.
Voltage too low.	<ul style="list-style-type: none"> a) Engine speed too slow. b) Generator is overloaded. c) Idle control is malfunctioning. 	<ul style="list-style-type: none"> a) Bring generator to a qualified technician for adjustment. b) Reduce the load. (See Power Load Planning & Mgt. section of this manual.) c) Bring generator to a qualified technician for inspection.
Circuit breaker trips.	<ul style="list-style-type: none"> a) Defective load connected to generator. b) Defective receptacle. c) Generator overloaded. 	<ul style="list-style-type: none"> a) Disconnect load. b) Replace receptacle. c) Reduce the load. (See Power Load Planning & Mgt. section of this manual.)
Voltage too high.	<ul style="list-style-type: none"> a) Engine speed too high. 	<ul style="list-style-type: none"> a) Bring generator to a qualified technician for adjustment.
Generator overheating.	<ul style="list-style-type: none"> a) Generator is overloaded. b) Insufficient ventilation. 	<ul style="list-style-type: none"> a) Reduce the load. (See Power Load Planning & Mgt. section of this manual.) b) Make sure there is at least 3 feet of clearance on all sides of generator.
No output voltage.	<ul style="list-style-type: none"> a) Defective load connected to generator. b) Broken or loose wire. c) Defective receptacle. d) Defective stator. e) Defective rotor. f) Defective capacitor. g) Circuit breaker tripped. 	<ul style="list-style-type: none"> a) Disconnect load. b) Bring generator to a qualified technician for repair. c) Replace receptacle. d) Bring generator to a qualified technician for repair. e) Bring generator to a qualified technician for repair. f) Bring generator to a qualified technician for repair. g) Reset circuit breaker and reduce loads connected to the generator.
Engine lacks power.	<ul style="list-style-type: none"> a) Generator is overloaded. b) Dirty air filter. 	<ul style="list-style-type: none"> a) Reduce the load. (See Power Load Planning & Mgt. section of this manual.) b) Clean or replace air filter.
Idle control doesn't work.	<ul style="list-style-type: none"> a) Switch is in OFF position. b) Solenoid failure. c) Defective circuit board. d) Circuit breaker tripped 	<ul style="list-style-type: none"> a) Place switch in ON position. b) Check for 12VDC at solenoid. Check coil resistance, it should be $18.0\Omega \pm 5\%$. Check for sticking in mechanism and solenoid. Replace idle assembly if necessary. c) Bring generator to a qualified technician for repair. d) Reset circuit breaker.
Engine shuts off during operation.	<ul style="list-style-type: none"> a) Out of fuel. b) Low oil level. 	<ul style="list-style-type: none"> a) Fill fuel tank. b) Fill crankcase to proper oil level.

Summary of Important Safety Information for Operation

This section provides a summary of the various safety procedures and measures that have been presented throughout the manual. Keep this summary handy and refer to it to refresh your memory about how to safely use your generator.

WARNING

Carefully read and make sure you understand the following safety information before using the generator. Improper use or maintenance of the generator can result in *serious injury or death* from *carbon monoxide poisoning, electric shock, fire/explosion, or burns*.

General

- **Read manual.** Read this Owner's Manual and the engine Owner's Manual completely before attempting to set-up and use the generator. Serious injury or death can result if safety instructions are not followed.
- **Instruct operators.** The generator owner must instruct all operators in safe generator set-up and operation. Do not allow anyone to operate the generator who has not read the Owner's Manual and been instructed on its safe use.
- **Adults only.** Only trained adults should set up and operate the generator. Do not let children operate.
- **Under the influence.** Never operate, or let anyone else operate, the generator while under the influence of alcohol, drugs, or medication.
- **Intended use.** Carefully read about and understand the intended use of this generator. Do not use for other purposes, as unforeseen hazards or equipment damage may result.

Prohibition Against Modifications

Never modify or alter the generator in any way. Modifications can create serious safety hazards and will also void the warranty.

- **Engine speed.** Never attempt to modify the engine speed setting. The engine speed is preset at 3600 RPM for safe and optimal performance of the generator. If speed needs adjusting, it must be done by factory-authorized personnel.
- **Fuel/exhaust system.** Never modify the exhaust system, fuel tanks, or fuel lines. Carbon monoxide poisoning, fire, or explosion could result.
- **Guards.** Do not operate generator unless all guards and cover shields, which prevent access to moving parts and pinch points, are in place. Failure to guard the power transmission mechanisms *may result in serious injury or death*.

Safety – Installation & Set-up

Battery Safety

Batteries are hazardous because they contain caustic acid, can emit explosive gases, and can cause electric shock. *Caution must be exercised when making connections to a battery to avoid shock and contact with the acid, and to prevent any sparking that could lead to an explosion.* Follow safety rules carefully when connecting battery to generator:

- **Eye/skin protection.** Always wear eye protection and protective clothing when connecting or disconnecting battery.
- **Sparks/Smoking.** Never smoke or work near sparks or other sources of ignition.
- **Electric shock.** Never touch both battery terminals at the same time with your hand or any non-insulated tools.
- **Connection/disconnection sequence.** ALWAYS connect and disconnect cables to the correct battery terminals in the proper sequence:
 - When CONNECTING the battery, connect the RED cable to the POSITIVE terminal FIRST.
 - When DISCONNECTING the battery, disconnect the BLACK cable from the NEGATIVE terminal FIRST
- **Acid/skin contact.** If battery acid contacts skin or clothing, flush immediately with water and neutralize with baking soda.

Summary of Important Safety Information for Operation (cont'd)

Installation / Initial Set-up Safety

- **Dry, level surface.** Situate generator on a dry, firm, level surface. Ensure generator sits level and will not slide or shift during operation. Block wheels if applicable.
- **Operate OUTSIDE only – dangerous carbon monoxide exhaust!** Generators give off carbon monoxide exhaust, a poisonous gas that can kill. You CANNOT smell it, see it, or taste it. ONLY run generator OUTDOORS and away from building air intakes. NEVER run generator inside homes, garages, sheds, or other semi-enclosed spaces. These spaces can trap poisonous gases, EVEN if you run a fan or open windows. Carbon monoxide is given off whether you are using gasoline, natural gas, or propane to power the generator.
- **No vehicle/marine use.** This generator is NOT designed or approved for use in vehicles or marine applications. Never run the generator inside RVs or other vehicles, on boats, or on pick-up truck beds.
- **Cooling ventilation.** The generator needs adequate, unobstructed flow of air to allow for proper cooling of engine and generator head. Situate so there is adequate clearance around generator to allow for cooling airflow. Do not allow debris to accumulate and block airflow.
- **Grounding.** Always ensure generator is properly grounded to prevent electrical shock. This generator is equipped with a grounding post. Always complete the grounding path from the generator to a copper pipe/rod driven into moist earth to a sufficient depth. Check with an electrician for local grounding requirements. If a licensed electrician installs the generator with a connection to your building's electrical circuit for use as a standby power system, grounding will be complete through the building's grounding system.
- **Isolate connection to building's electrical circuit.** Never plug the generator directly into a wall outlet. ANY connection to a building's electrical system MUST ISOLATE THE GENERATOR FROM UTILITY POWER via an UL-approved transfer switch installed by a licensed electrician in compliance with all applicable local building and electrical codes. If the generator is not isolated from the utility power system by such means, generator output will back feed into the utility power grid. This may result in injury or death to utility power workers or others who contact the lines during a power outage. It may also cause the generator to explode or cause fires when utility power is restored.
- **Wet conditions.** Water conducts electricity. Do not operate generator where it is wet. Operate on a dry surface under an open, canopy-like structure.
- **CO alarms.** Ensure that working, battery-operated or battery back-up carbon monoxide alarms are used in any dwelling/structure that is in close proximity to the running generator.
- **Hot exhaust - fires.** Exhaust from engine can be extremely hot and cause fire. Position muffler at least 7' from combustible objects during operation.
- **Spark arrestor.** Equip engine with a spark arrestor if generator will be used near any ignitable forest, brush, or grassy land. See the "Specifications" section of this manual to determine if your generator is already equipped. Make sure you comply with applicable local, state and federal codes.
- **Fire extinguisher.** Keep a fire extinguisher rated "ABC" by the National Fire Protection Association nearby. Keep it properly charged and be familiar with its use.

Safety – Before Use

Know how to operate

- **Review safety rules.** Before each use of this generator, review the "Rules for Safe Operation." Failure to follow these rules may result in serious injury or death.
- **Know how to operate.** Be thoroughly familiar with all controls and with the proper use of the equipment. Know how to stop the generator quickly if needed.

Personal protective equipment

- **Hearing protection.** The use of ear plugs or other hearing protection device is recommended for those in close proximity to the generator while it is operating.
- **Loose / dangling.** Loose or dangling apparel can become entangled in moving parts. Metal jewelry can conduct electricity. Never wear jewelry or loose-fitting clothing when operating the generator.

Summary of Important Safety Information for Operation (cont'd)

Gasoline Safety

Gasoline is highly flammable and explosive. You can be burned or seriously injured when handling fuel. Use extreme care when handling:

- **Fuel outdoors.** Fill fuel tank outdoors – never indoors. Gasoline vapors can ignite if they collect inside an enclosure. Explosion can result.
- **Use approved container.** Never pump fuel directly into engine at gas station. Static charge can build and ignite fuel. Use an UL approved fuel container to transfer gas to the engine.
- **Running / hot engine.** A running engine is hot enough to ignite fuel. Never add fuel or remove gas cap if engine is running or still hot. Stop the engine and allow to cool at least two minutes before adding fuel.
- **Heat / flames / sparks.** Stay away from sources of heat, flame, or sparks while adding fuel.
- **Don't overfill.** DO NOT overfill the gas tank. Allow at least 1/2" of empty space below the fill neck to allow for fuel expansion.
- **Replace cap.** Replace gas cap securely before starting engine.
- **Spills.** Clean up fuel spills immediately. Move generator away from spilled fuel on the ground. Wipe fuel off engine and wait 5 minutes for excess fuel to evaporate before starting engine. Gas soaked rags should be disposed of properly.
- **On skin / clothes.** If gasoline is spilled on your skin or clothes, change clothes and wash skin immediately.
- **Inspect fuel system.** Check fuel system on a regular basis. Look for signs of leaks, deterioration, chafed or spongy fuel hose, loose or missing fuel hose clamps, damaged fuel tank, or a defective fuel shut-off valve. Do not start generator until needed repairs have been completed.
- **Gasoline storage.** Store gasoline in a cool, dry place in an UL-approved, tightly sealed container.

Safety – During Use

- **Safety equipment / controls.** Always operate the generator with all safety covers, guards, and barriers in place and in good working order, and all controls properly adjusted for safe operation.
- **Know how to stop.** Be thoroughly familiar with proper use of the equipment and all generator controls, output receptacles, and connections. Know how to stop the generator quickly if needed.
- **Damaged.** Do not operate the generator with damaged, missing, or broken parts.
- **Carbon monoxide exhaust.** The running engine gives off carbon monoxide, a poisonous gas that can kill you. You CANNOT smell it, see it, or taste it. If you start to feel sick, dizzy, or weak while using the generator, shut off the engine and get to fresh air RIGHT AWAY. See a doctor. You may have carbon monoxide poisoning.
- **Other exhaust dangers.** This product contains or emits chemicals known to the State of California to cause cancer, birth defects or other reproductive harm. Avoid inhalation of exhaust.
- **Smoking/sparks.** Never smoke near the running generator, and never operate near sources of sparks or flames.
- **Check output voltage.** Check output voltage to ensure the generator is working properly before connecting loads to the generator. Failure to do so could result in damage to equipment powered by the generator and possible injury to the individual. Do not adjust output speed of engine to change voltage. If voltage is not within specified range, have generator repaired by factory authorized personnel.
- **Stabilize before connecting loads.** Start generator and let engine stabilize before connecting electrical loads.
- **Do not overload.** Do not overload the generator. Make sure that combined starting and running loads do not exceed rated capacity of generator or damage will result.
- **Protect sensitive electronics.** Some electronic equipment, such as computers and audio/video equipment, can be damaged by small fluctuations in the flow of power. Use a surge suppressor for any voltage-sensitive electronic equipment you will be powering with the generator.
- **Wet conditions.** Do not operate the generator or handle any electrical equipment while standing in water, while barefoot, while hands are wet or while in the rain or snow. Electric shock may result.
- **Ground fault circuit interrupter.** Always use a ground fault circuit interrupter (GFCI) protected extension cord (or outlet, if generator is equipped) in damp or highly electrical conductive areas and on construction jobsites to prevent electrical shock.
- **Electrical cords.** Use only UL-listed, outdoor-rated, three prong extension cords of the proper size. All extension and appliance cords must be in good condition and not worn, bare, frayed, or otherwise damaged. Use of inadequate or damaged electric cords can cause electric shock or fire.
- **Avoid contact.** Avoid contact with bare wires, terminals, connections, etc. while the unit is running.

Summary of Important Safety Information for Operation (cont'd)

- **Electric shock accident.** If an electric shock accident occurs, immediately shut down the source of electrical power. If this is not possible, attempt to free the victim from the live conductor. Avoid direct contact with victim. Use a nonconducting implement, such as a dry rope or board, to free the victim from the live conductor. Apply first aid and get immediate medical help.
- **Hot muffler.** Never touch hot muffler, hot exhaust manifold, or engine cooling fins. Exhaust and engine parts can be very hot and will burn you.
- **Moving parts.** Keep hands, feet, and apparel away from drive belts, fans, and other moving parts. Never remove any drive belt or fan guard while the unit is operating.
- **Refueling.** DO NOT refuel the engine until it has cooled at least two minutes.
- **Malfunction during operation.** Immediately turn off the generator if any of the following conditions arise during operation:
 - Excessive change in engine speed, slow or fast
 - Overheating in load connecting devices
 - Sparking or arcs from generator
 - Loss of electrical output
 - Receptacle damage
 - Engine misfire
 - Excessive vibration
 - Flame or smoke
 - Abnormal noise
- **Adjusting / repairing.** Always turn off generator and remove spark plug(s) or spark plug wire(s) before working on the generator to prevent accidental starting.

Safety – After use

- **Cool engine before storing.** Let engine cool for at least five minutes before storing. A hot engine can be a fire hazard.
- **Shut off fuel supply.** Make sure gasoline shut-off valve is in the OFF position.
- **Prevent accidental starting.** When generator is not in use, remove key from starter (key start engines) and secure in a safe location, or remove spark plug(s) in order to ensure that generator cannot be started in a storage location or by untrained persons.
- **Storage location.** Store the generator in a dry location away from sources of heat, open flames, sparks or pilot lights – such as water heaters, space heaters, furnaces, clothes dryers, or other gas appliances – EVEN IF the generator's gas tank is empty. Residual gasoline could ignite.
- **Exercise regularly.** Exercise generator every four weeks to dry out moisture that accumulates in the windings. If generator cannot be exercised on a regular basis, prepare generator for long term storage.
- **Periodic maintenance.** Perform periodic maintenance as directed in this manual to keep the generator in safe working condition.

Safety - Inspection/Maintenance

Inspect and maintain your generator on a regular basis and repair as needed to keep it in safe working condition:

- **Turn off generator.** Always turn off generator and remove spark plug(s) or spark plug wire(s) before working on the engine or generator to prevent accidental starting.
- **Discharge capacitor.** When the generator is shut down, the capacitor may maintain a charge. Always discharge the capacitor before working on the generator head to prevent electrical shock.
- **Replace guards / shields.** Make sure all guards and shields are replaced after servicing the generator.
- **Replacement parts.** If a part needs replacement, only use parts that meet the manufacturer's specifications. Replacement parts that do not meet specifications may result in a safety hazard or poor operation of the generator and will void the warranty.

Generator Exploded View Rev - S

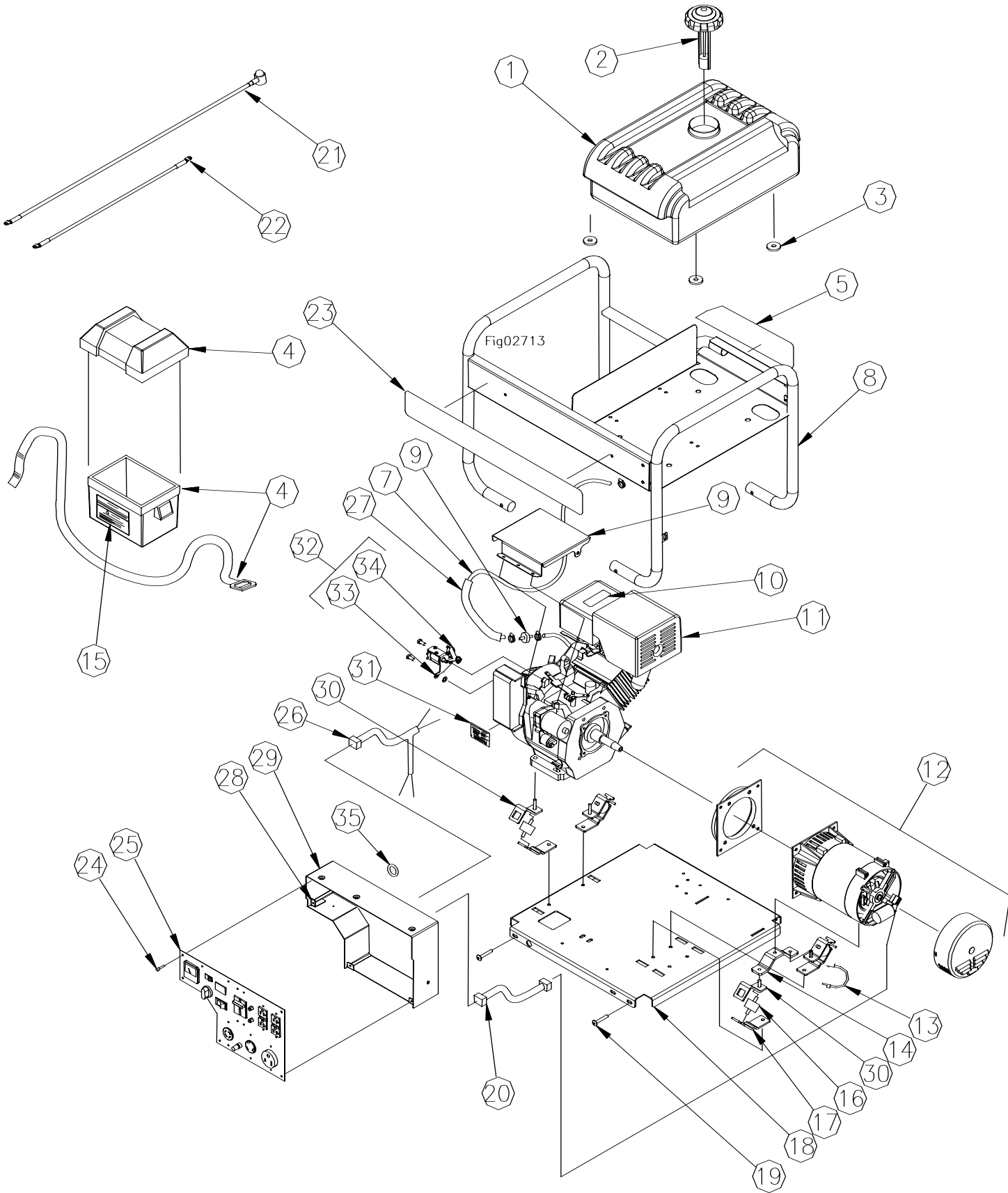

Generator Exploded View Rev – S

Diag #	Part #	Description	Qty
1	38759	Fuel Tank Assembly	1
2	33321	Fuel Cap	1
3	30754	Leather Washer	4
4	777352	Battery Box	1
5	779422	Decal	1
6	171410	Fuel Clamp	3
7	777345	Fuel Line	33"
8	32833	Cradle Weldment	1
9	38184	Engine Cover	1
10	39260	Hot Muffler Decal	1
11	31043	9 HP Honda Engine	1
12	778529	Generator Head	1
13	306459	Engine Ground Wire	1
14	777302	Generator Bracket	1
15	779396	Battery Warning Decal	1
16	34172	Isolation Mount	4
17	32844	Bottom Bracket	4
18	778484	Generator Base	1
19	82018	5/16 - 18 X 2" Bolt	4
20	38607	Generator Wiring Harness	1
21	777164	Battery Cable, Positive	1
22	777108	Battery Cable, Negative	1
23	779423	Decal	1
24	82007	Screw, #10-32 X .75	6
25	38582	Control Panel Assembly	1
26	38608	Idle System Wiring Harness	1
27	38613	Protective Sleeve	16"
28	82067	Clip Nut, #10-32	6
29	777297	Control Box Weldment	1
30	32848	Top Bracket	4
31	33271	Nameplate	1
32	38576	Idle Assembly	1
33	31032	Idle Assembly Base	1
34	31080	Idle Assembly Arm	1
35	30748	Access Cap	1

Wiring Diagram Rev- S

Diag #	Part #	Description	Qty
1	38595	Control Panel Plate	1
2	33827	Voltmeter	1
3	31211	Mounting Clip	4
4	306428	Rocker Switch, 20A 2-Pole	1
5	31334	NEMA Receptacle 5-50R, 50A 120V	1
6	31344	GFCI Duplex Receptacle, 20A 120V	1
7	306446	NEMA Receptacle L14-20R, 20A 120/240V	1
8	306429	Binding Post	1
9	31083	Circuit Breaker, 20A 120/240V 2-Pole	1
10	31084	Rocker Switch, 16A 1-Pole	1
11	31085	Thermal Circuit Breaker, 20A	1
12	31086	Thermal Circuit Breaker, 30A	1
13	306423	NEMA Receptacle L5-30R, 30A 120V	1
14	32805	Hour Meter	1
15	306426	Duplex Receptacle, 20A 120V	1
16	781012	Idle Control Board	1
17	38468	Idle Board Bracket	1
18	38585	Standoff	2
19	781013	Current Transformer	1
20	5253	0.250 x 0.032 Terminal	2
21	38614	Connector Wire Harness (B11, B31, B41, G11, W21, W20, W22, W27, W28, NG)	1
22	38621	Connector Wire Harness (G12, G13, G14, G15, G16, G17, G18)	1
23	38647	Connector Wire Harness (1, SW, 3, 4)	1
24	82004	#8-32 X ½ BHCS	18
25	82005	#8-32 Keps Nut	19
B12,B13	38615	Wire Assembly	1
B17,B19	38616	Wire Assembly	1
B20,B21	38617	Wire Assembly	1
B42	38618	Wire Assembly	1
B43	38619	Wire Assembly	1
W23 - W25	38620	Wire Assembly	1
B18	38622	Wire Assembly	1
W26	38623	Wire Assembly	1
W1	38624	Wire Assembly	1
B15	777189	Wire Assembly	1
B14,B16	777188	Wire Assembly	1

Generator Head Exploded View Rev – S

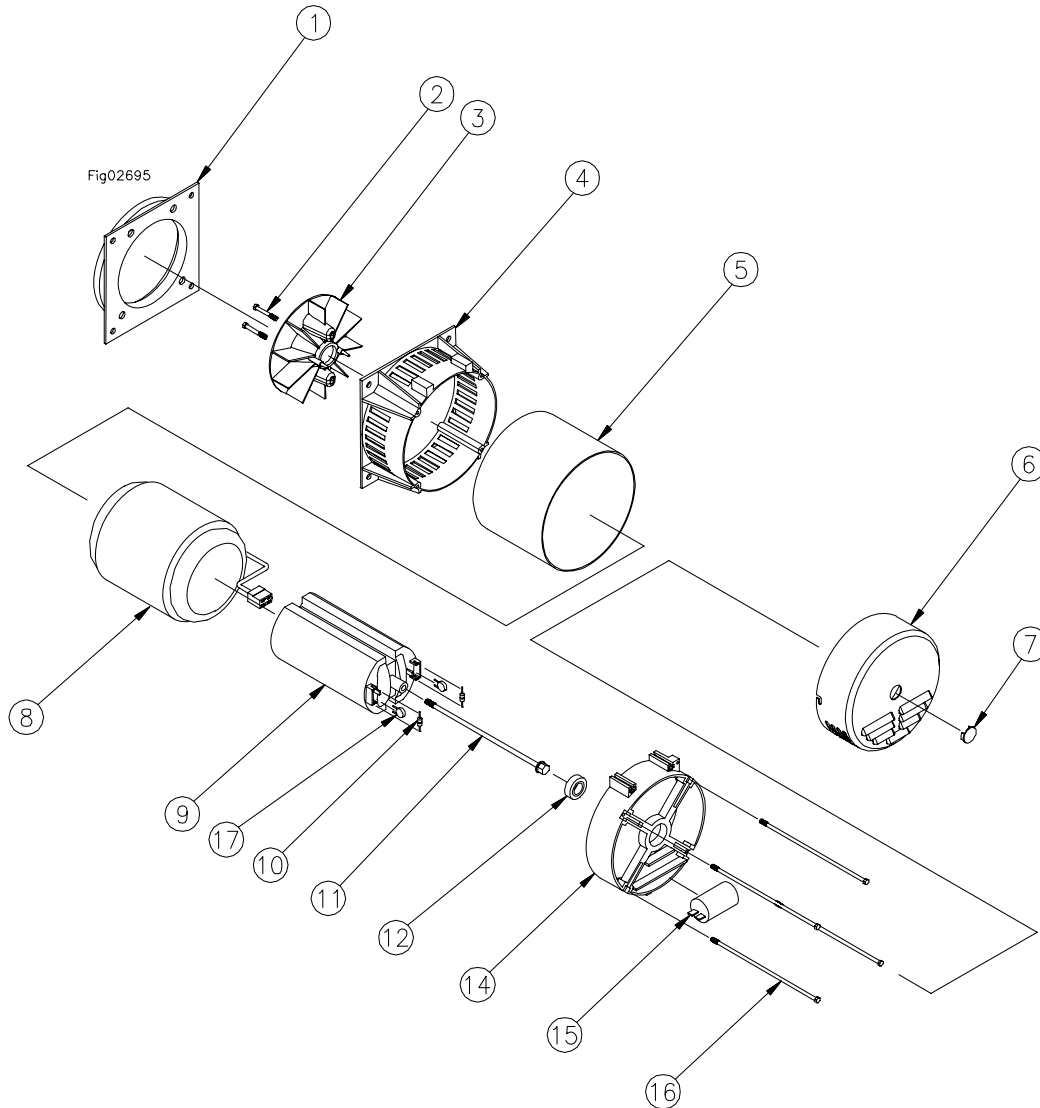

Diag #	Part #	Description	Qty
1	305522	Mount Plate (J609B)	1
2	306404	Fan Bolts	2
3	778953	Fan	1
4	306406	Drive End Bracket	1
5	778954	Enclosing Band	1
6	305554	End Cover	1
7	306408	End Cover Plug	1
8	778955	Stator	1
9	778956	Rotor	1
10	778959	Diode	2
11	778957	Securing Stud	1
12	307485	Bearing	1
14	306417	Non Drive End Bracket	1
15	778958	Capacitor	1
16	778960	Bracket Securing Stud	4
17	778961	Varistor	2

This page has intentionally been left blank.

Limited Warranty

Dear Valued Customer:

The NorthStar Product you just purchased is built with the finest material and craftsmanship. Use this product properly and enjoy the benefits from its high performance. By purchasing a NorthStar product, you show a desire for quality and durability.

Like all mechanical equipment this unit requires a due amount of care. Treat this unit like the high quality piece of machinery it is. Neglect and improper handling may impair its performance. Please thoroughly read the instructions and understand the operation before using your product.

Limited Warranty

NorthStar shall warranty any piece of equipment manufactured, or parts of equipment manufactured, to be free from defects in material or workmanship for a period of 2 years from the date of purchase by user. This warranty applies to the original purchaser of the equipment and is non transferable. Verification of purchase is the responsibility of the buyer. Parts will be replaced or repaired at no charge, except when the equipment has failed due to lack of proper maintenance. Any misuse, abuse, alteration or improper installation or operations will void warranty. Determining whether a part is to be replaced or repaired is the sole decision of NorthStar.

NOTE: Some services performed by parties other than NorthStar may void warranty.

This warranty covers parts only. It will not provide for replacement of complete products due to defective parts. Components not manufactured by NorthStar such as engines are guaranteed by their manufacturer and can be serviced at factory-authorized locations near you. Any costs incurred due to replacement or repair of items outside of a NorthStar approved facility is the responsibility of the buyer and not covered under warranty. NorthStar can supply you with the service center location in your area.

This warranty specifically excludes the following; failure of parts due to damage caused by accident, fire, flood, windstorm, acts of God, applications not approved by NorthStar in writing, corrosion caused by chemicals, use of replacement parts which do not conform to manufacturer's specifications, and damage caused by vandalism. Additional exclusions: loss of running time, inconvenience, loss of income, or loss of use, including any implied warranty of merchantability of fitness for a specific use.

Warranty does not cover items subject to normal wear such as tires, receptacles or any part subject to direct physical contact by the public. This warranty does not cover any personal injury or damage to surrounding property caused by failure of any part.

This warranty is in lieu of any other warranty expressed or implied and NorthStar assumes no other responsibility or liability outside that expressed within this warranty.

Please fill in the following information and have it on hand when you call in a warranty claim.

Customer Number: _____

Date of Purchase: _____

NorthStar Serial Number: _____

Item Number: _____



Manufactured by
Northern Tool + Equipment Co.,
2800 SouthCross Drive West
P.O. Box 1499 Burnsville, MN 55337-0499