

## FLAT PANEL MONITOR ARM

Concerto 27820H Dual Monitor Arm

# The Next Generation



## Concerto

Item No. 27820H

The new Concerto is a stunning take on an already brilliant innovation. One part workhorse, one part museum piece, this new monitor arm continues in the fine tradition of its predecessor and builds on a sterling reputation.

### Concerto's Unique Features

- Quick Connect allows fast, simple assembly.
- Flexibility and more options for the end user with a simple, easy-to-use Allen wrench adjustment to counter balance the weight of the monitor.
- Double Extension models allow 24" of back and forth movement. Arm folds back to post for more desk space.
- The arm swivels 360° around the base, increasing the options for display position
- Options are available for panel, wall and slatwall mounting configurations
- Desk clamp and grommet mount hardware are included to minimize SKUs
- Clamp and grommet adjustable to fit most desks and work surfaces
- With a clamping range of 1/2" to 2 3/4" that is standard for the Concerto, this new arm will fit to any work surface
- New cable manager keeps all cables hidden
- Monitor mounting bracket, with Quick Connect option, contains 75x75mm, 100x100mm, 200x200mm and 100x200 hole patterns to meet with VESA standards
- Choice of finishes - silver, white, black or polished

1.866.INTELLA  
www.intellaspaces.com

  
by Mesa

# FLAT PANEL MONITOR ARM

## Concerto 27820H Dual Monitor Arm

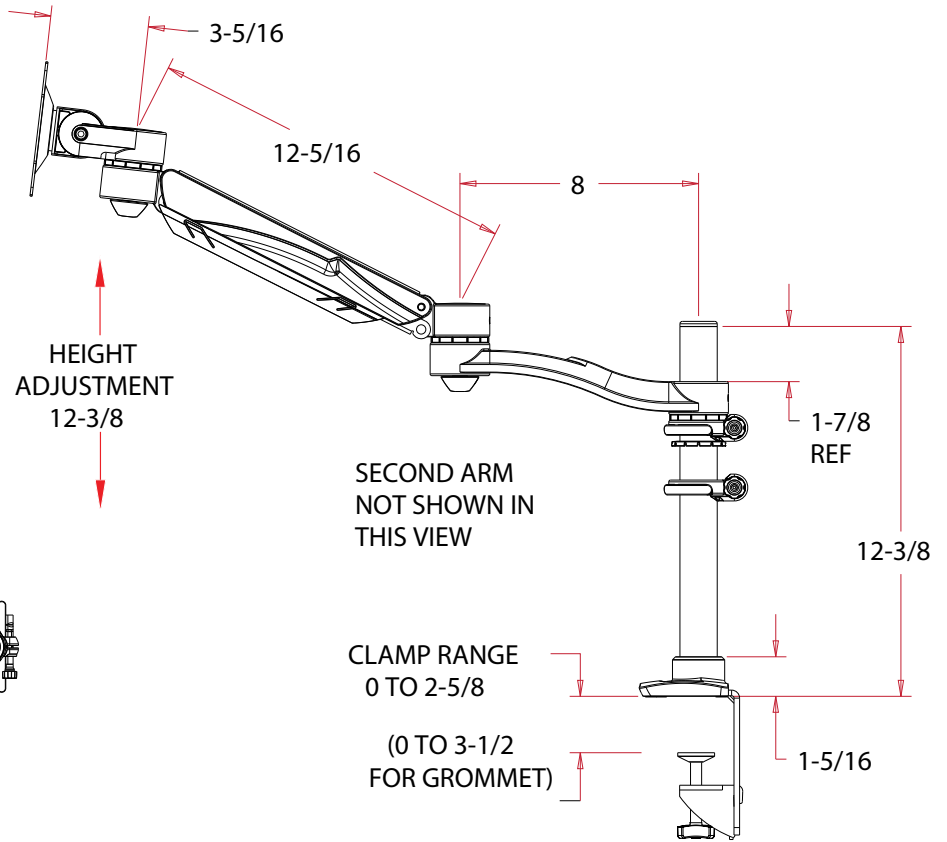
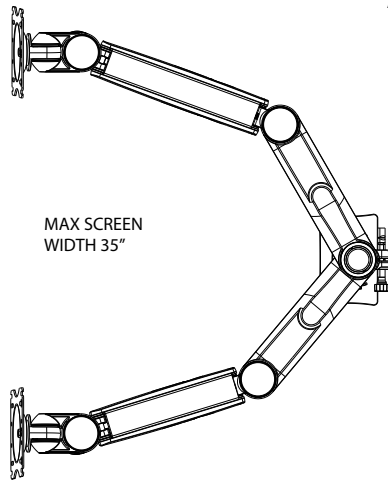
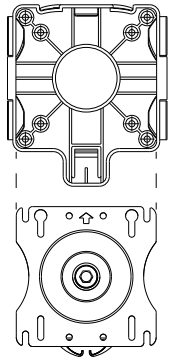

### Concerto with Height Adjustable Arm

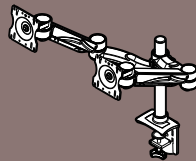

27820H Dual screen, dual extension monitor arm with height adjustable segments. Includes quick disconnect adapters. 20 lb. per screen load capacity

1.866.INTELLA  
www.intellaspaces.com

**intellaspaces**<sup>TM</sup>  
by Mesa