

# esi

Assembly instructions

# Trada™ 2-Leg

Electric height adjustable table base

Model # 2TD-C48-24-\_\_\_\_

Model # 2TD-C48-30-\_\_\_\_

\_\_\_\_ = SLV, BLK or WHT



**Caution**

- Do not use impact drivers or other high-torque equipment. Use power drill on self-tapping wood screws only.
- Always check that screws used to attach components to the worksurface are not too long for the thickness of the table. The provided screws require a minimum table thickness of 1.0".

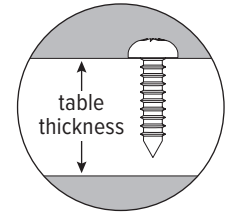

**Please review** these instructions before beginning the installation. Use the illustrations below to check that all components needed for your installation were provided with your order. Do not discard the packaging until the product works to your satisfaction.

**Components and tools**

- A. crossbars (2)
- B. legs with motor and cable (2)
- C. feet (2)
- D. universal side brackets (2)
- E. power supply holder (1)
- F. power supply (1)
- G. power cord (1)
- H. handset (1)
- I. control unit (1)
- J. round rubber bumpers (10)
- K. square rubber bumpers (2)
- L. 3mm Allen key  
*used for set screws*
- M. 5mm Allen key  
*used for M8x16 socket screws*
- N. M8x16 flat head socket screws (8)  
*attach crossbars to motors*
- O. M8x16 round head socket screws (4)  
*attach feet to legs*
- P. 1/4–20x5/8" Phillips flat head screws (4)  
*attach side brackets to crossbars*
- Q. #10x1" self-tapping Phillips pan head screws (4)  
*attach side brackets to worksurface*
- R. #10x2 1/2" self-tapping Phillips pan head screws (10)  
*attach crossbars to worksurface*
- S. #6x5/8" Phillips self-tapping round head screws (10)  
*attach handset, control unit, and cord clips to worksurface*
- T. cord clips (6)

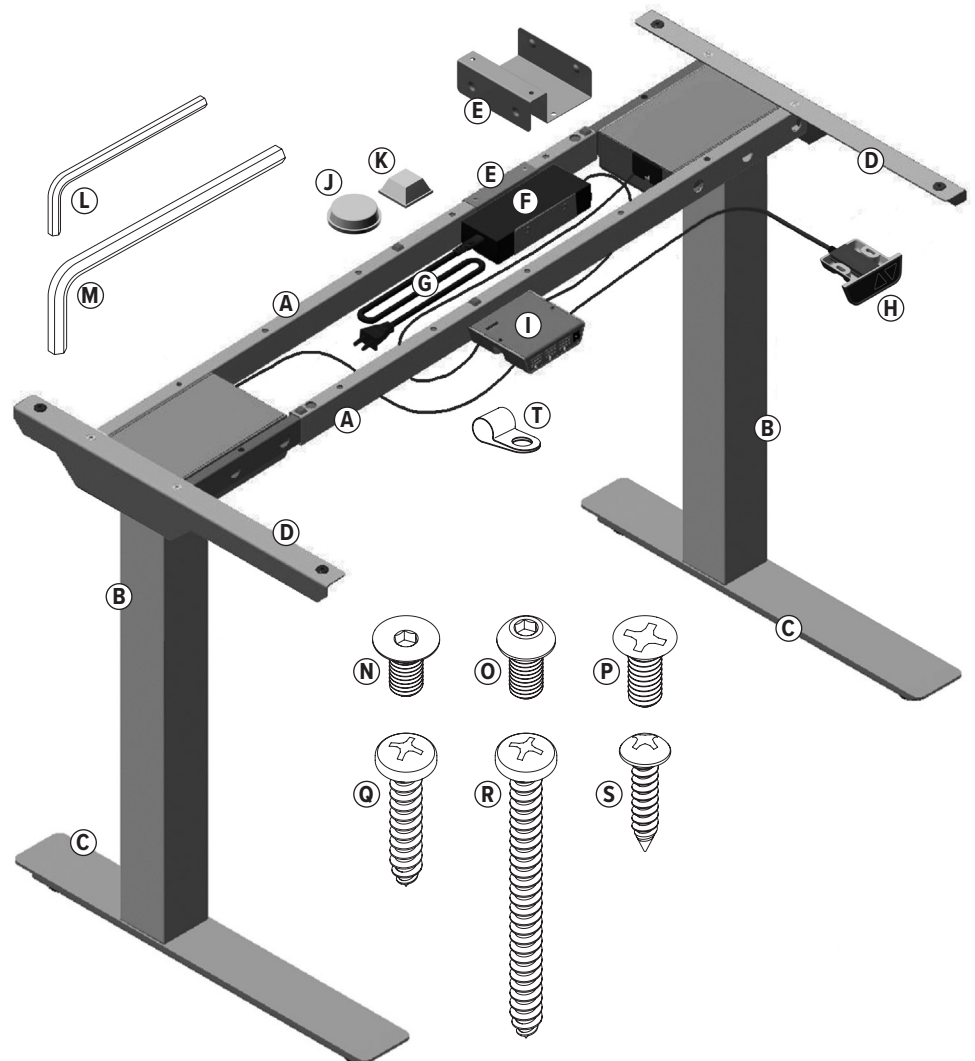
**Additional tools required**

- Power drill with Phillips #2 bit for self-tapping wood screws only
- #3 Phillips screwdriver



### Step #1: attach legs to crossbars

- Position the two legs and crossbars as shown.
  - Position the exposed inner channel of the crossbars against the front of the right motor housing and against the rear of the left motor housing.
- Using the 4mm Allen key, attach the crossbars to the motor housing with the M8x16 flat head socket screws (8 screws total).
  - Tighten all screws securely.

**CAUTION:** Do not insert any object through the middle holes on the housing. Doing so can damage electronic components.

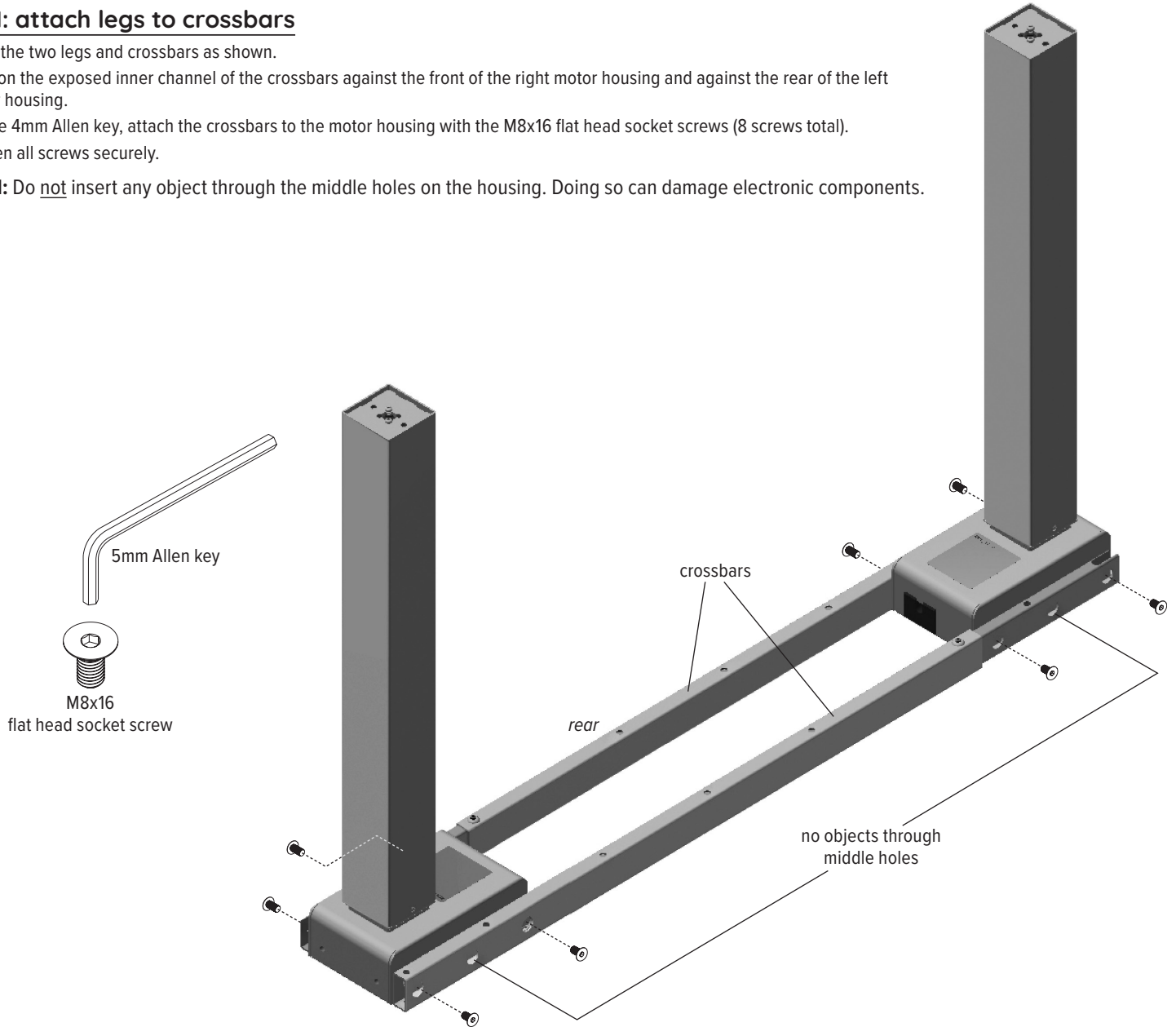

### Step #2: attach feet to legs

- Using the 4mm Allen key, attach the feet to the legs with the M8x16 round head socket screws.
  - Be sure the short end of each foot is toward the rear.

**CAUTION:** Do not interchange the flat head socket screws in step #1 with the round head socket screws in step #2.

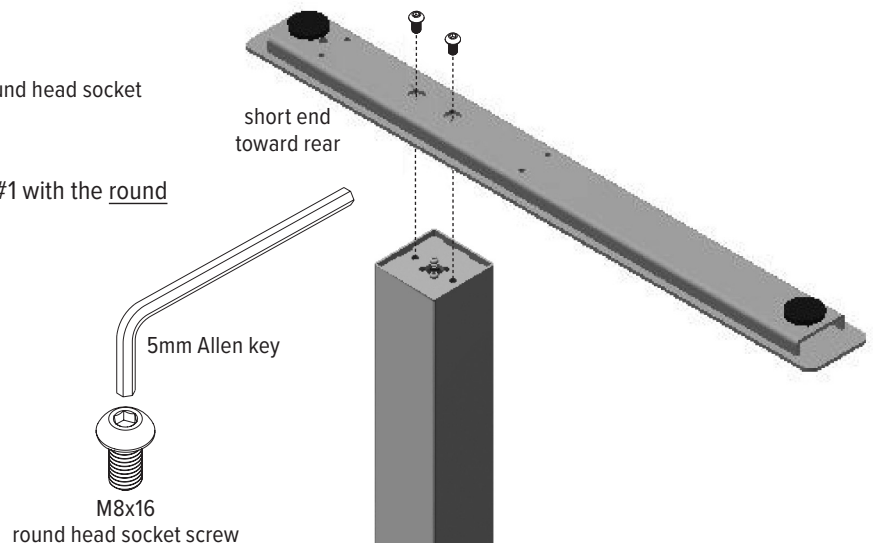



### **Step #3: attach universal side brackets to crossbars**

- Turn the table upright so that it rests on the two feet.
- Using a #3 Phillips screwdriver, attach the universal side brackets to the crossbars with the  $\frac{1}{4}$ -20x $\frac{5}{8}$  flat head screws.
  - Be sure the short end of each side bracket is toward the rear.

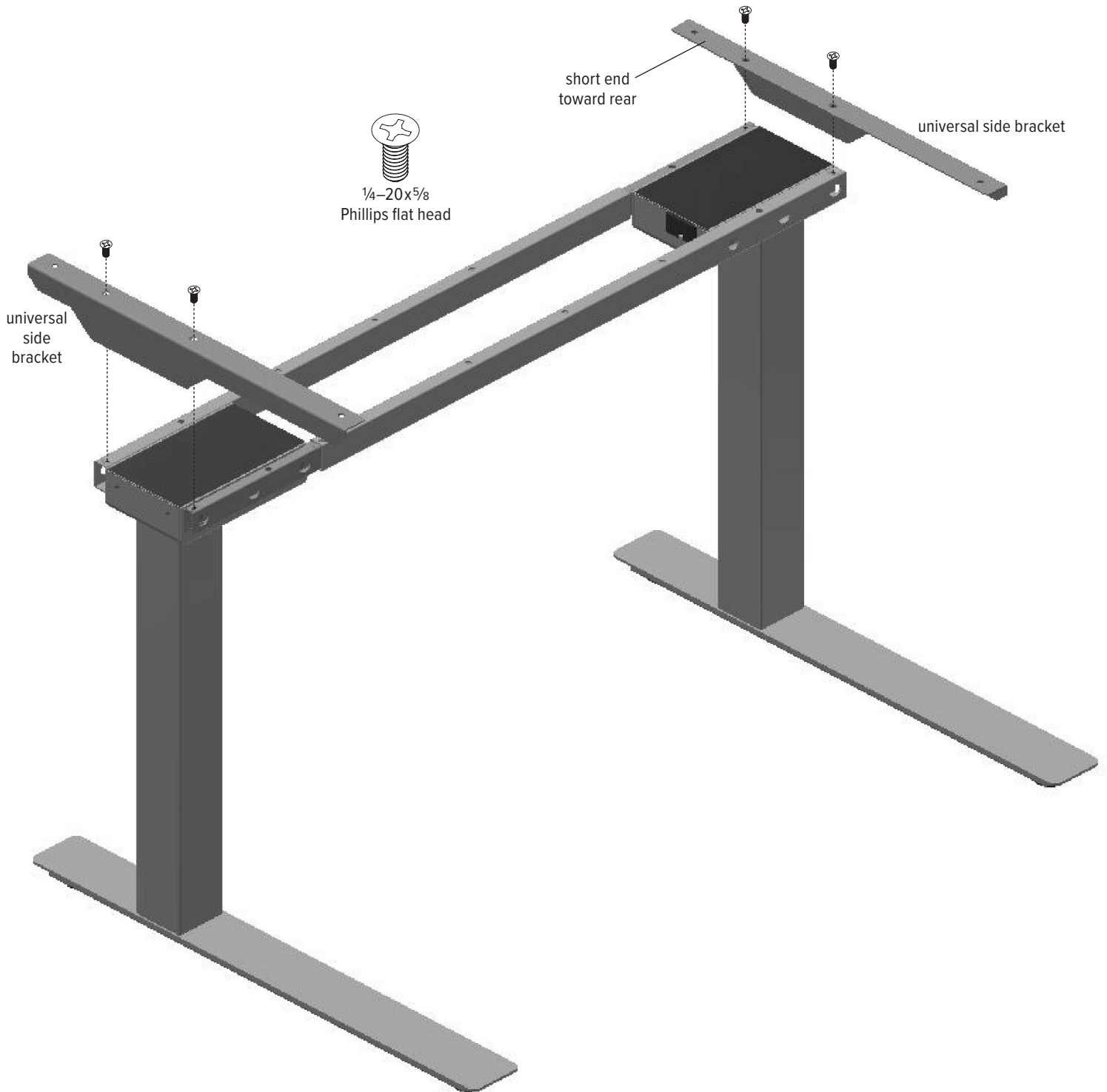



### **Step #4: adhere bumpers onto crossbars**

Rubber bumpers help protect against worksurface damage and ensure smooth up-down operation. The bumpers are self-adhesive. Simply peel the backing and press the bumpers into position.

- Adhere one round rubber bumper midway between the motor housings on each crossbar.
  - Do not place a round bumper onto the exposed inner channel next to the motor housings.
- Adhere the remaining round bumpers next to each hole that could be utilized for attaching the worksurface to the frame.
- Adhere one square rubber bumper next to the end through-hole on each inner channel.

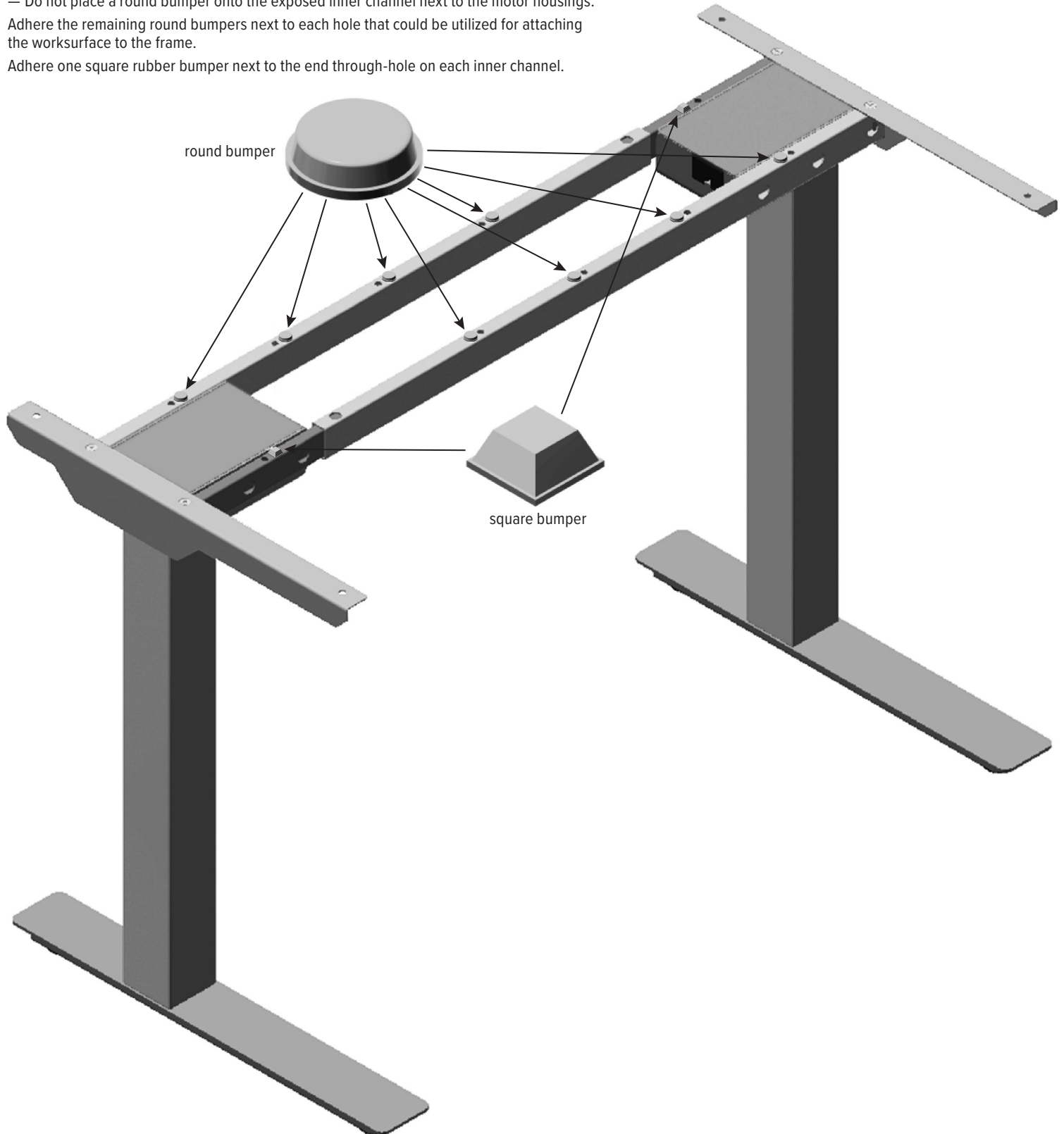



### Step #5: position assembled frame on underside of worksurface

With the table top facing down on a soft, clean surface, turn the assembled frame upside-down and center it on the underside of the worksurface.

- Use a 3mm Allen key to loosen the set screw on each crossbar near the end where the exposed channel begins.
- Expand the crossbars as necessary to position the side brackets 1.0" from the left and right edges of the worksurface.
  - Be careful not to dislodge any of the rubber bumpers when expanding the crossbars.
- Tighten the set screws to securely hold the side-to-side width of the crossbars.

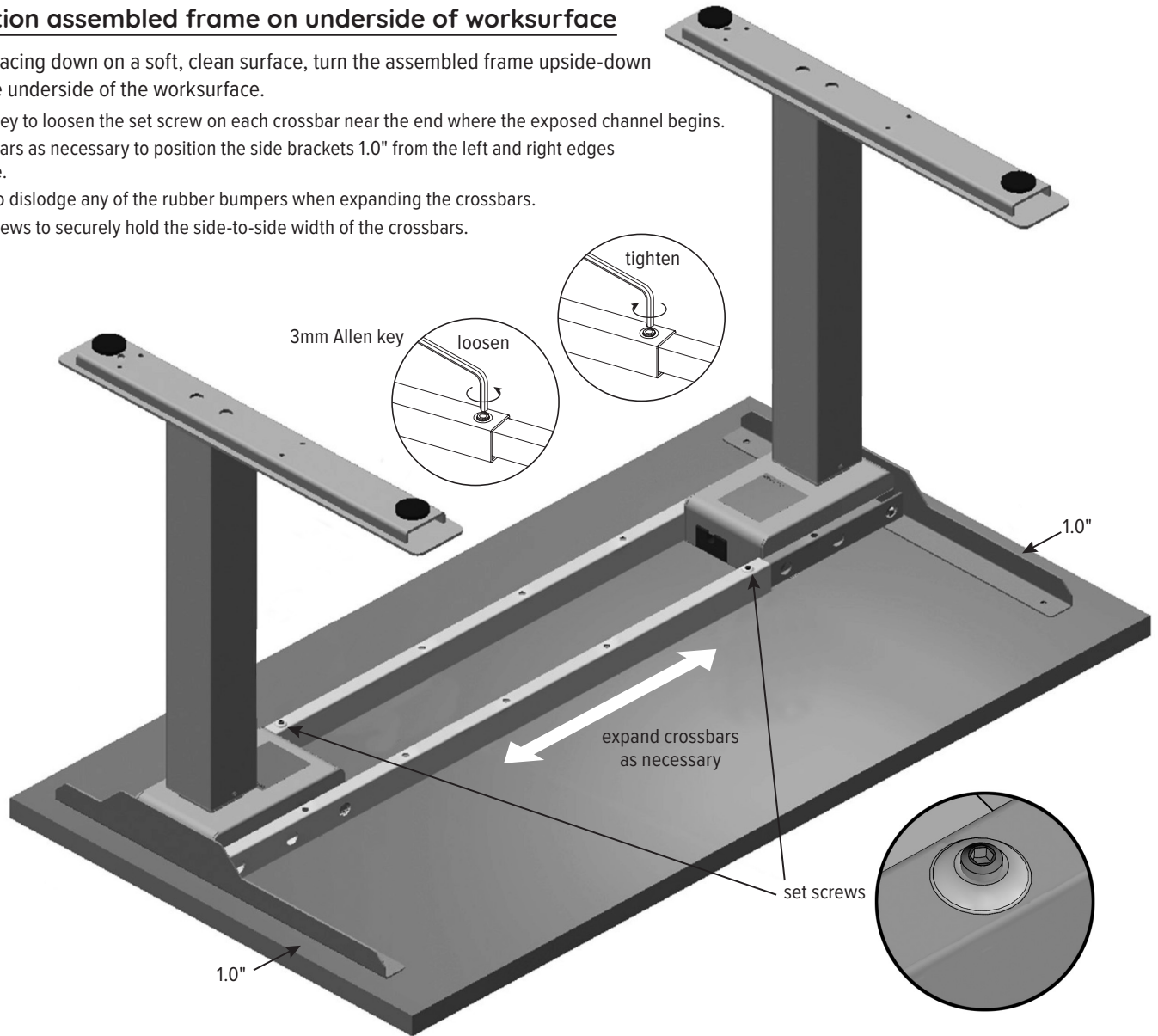

### Step #6: hook power supply holder under rear crossbar

- Raise the rear crossbar just enough to hook the holder for the power supply in the desired position.
  - Position the holder so that the power supply will be located between the two crossbars.
  - Position the holder so it does not cover any of the through-holes used to attach the crossbars to the worksurface.
  - Be sure the holder does not cover any of the rubber bumpers.

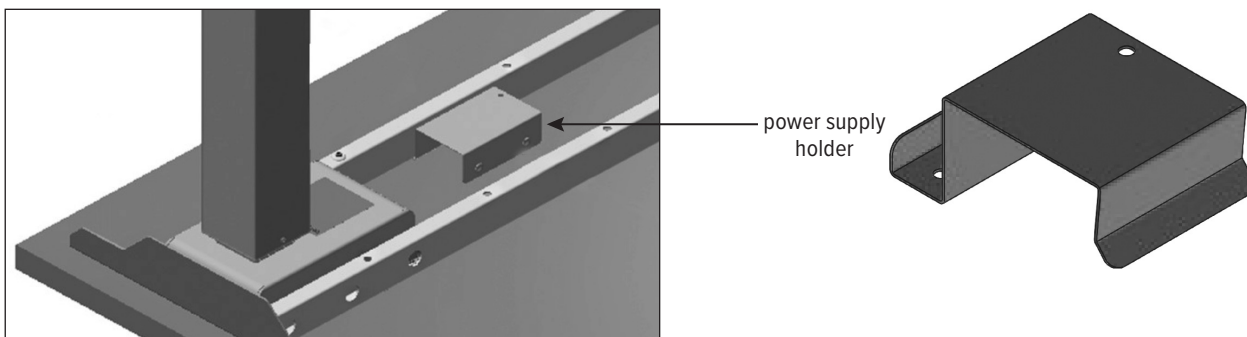



### Step #7: screw side brackets to worksurface

- Align the rear of the feet with the rear edge of the table
- Double-check that the frame is centered side-to-side.
- Screw the side brackets to the table using two #10x1" wood screws per bracket.

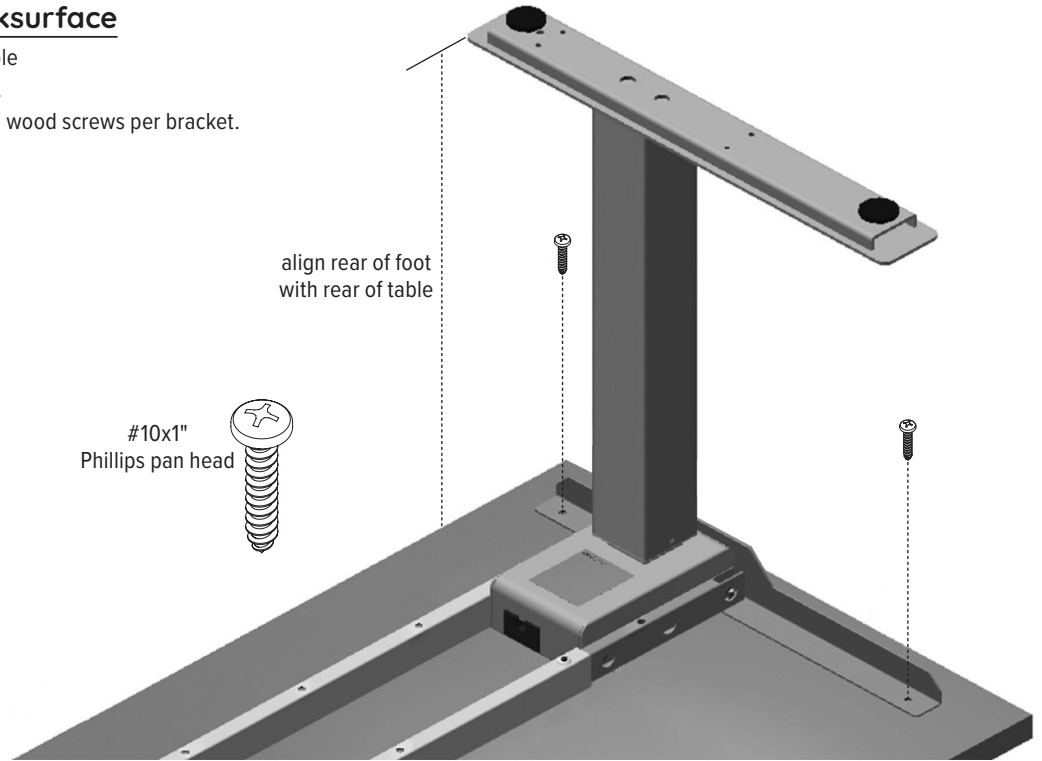

### Step #8: screw crossbars to worksurface

- Screw the crossbars to the table using from two to five #10x2½" wood screws per crossbar.
  - Use all available crossbar-to-worksurface holes. The number of these holes depends on how much the crossbars were expanded in step #5. In the example below, two screws per crossbar are used.

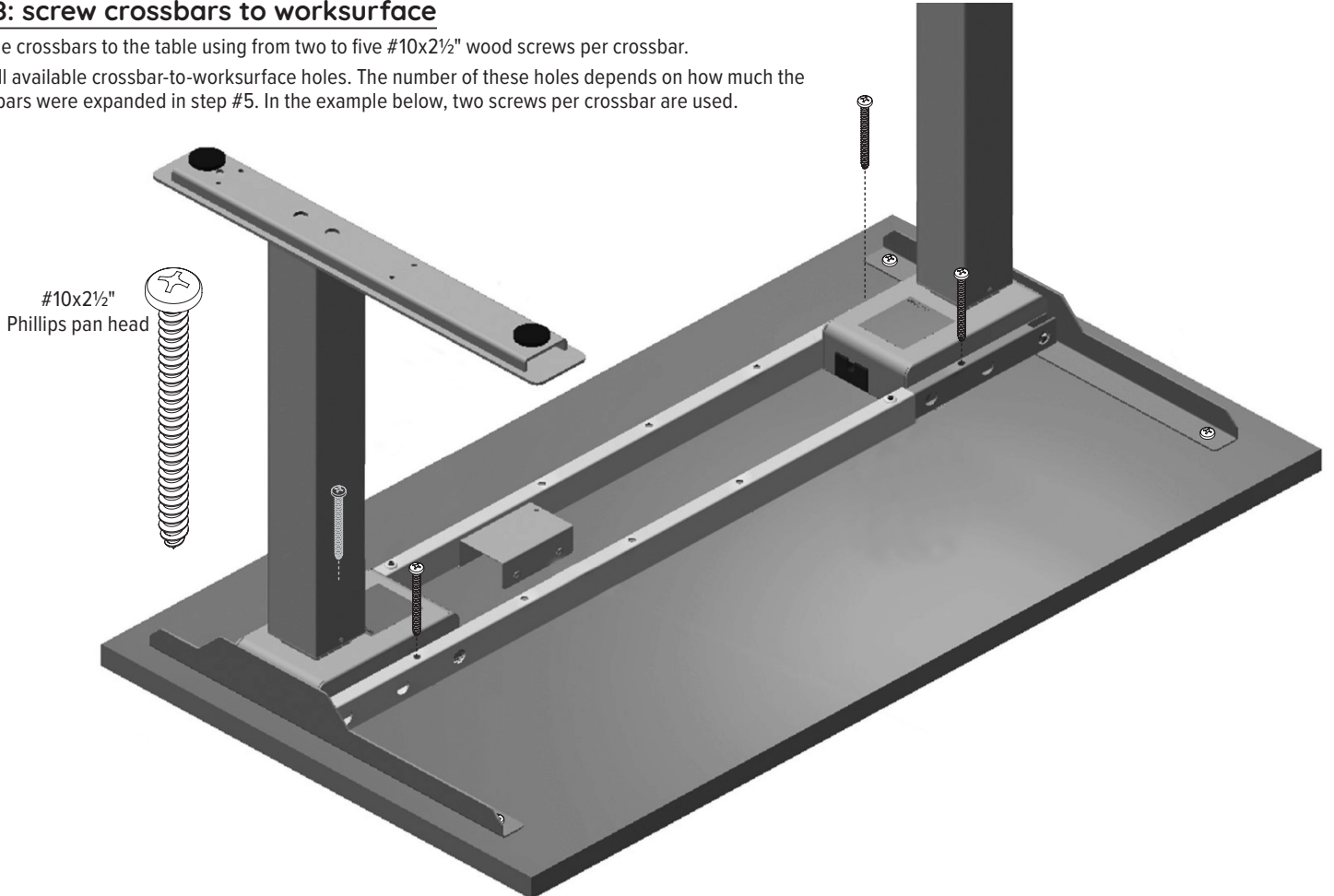

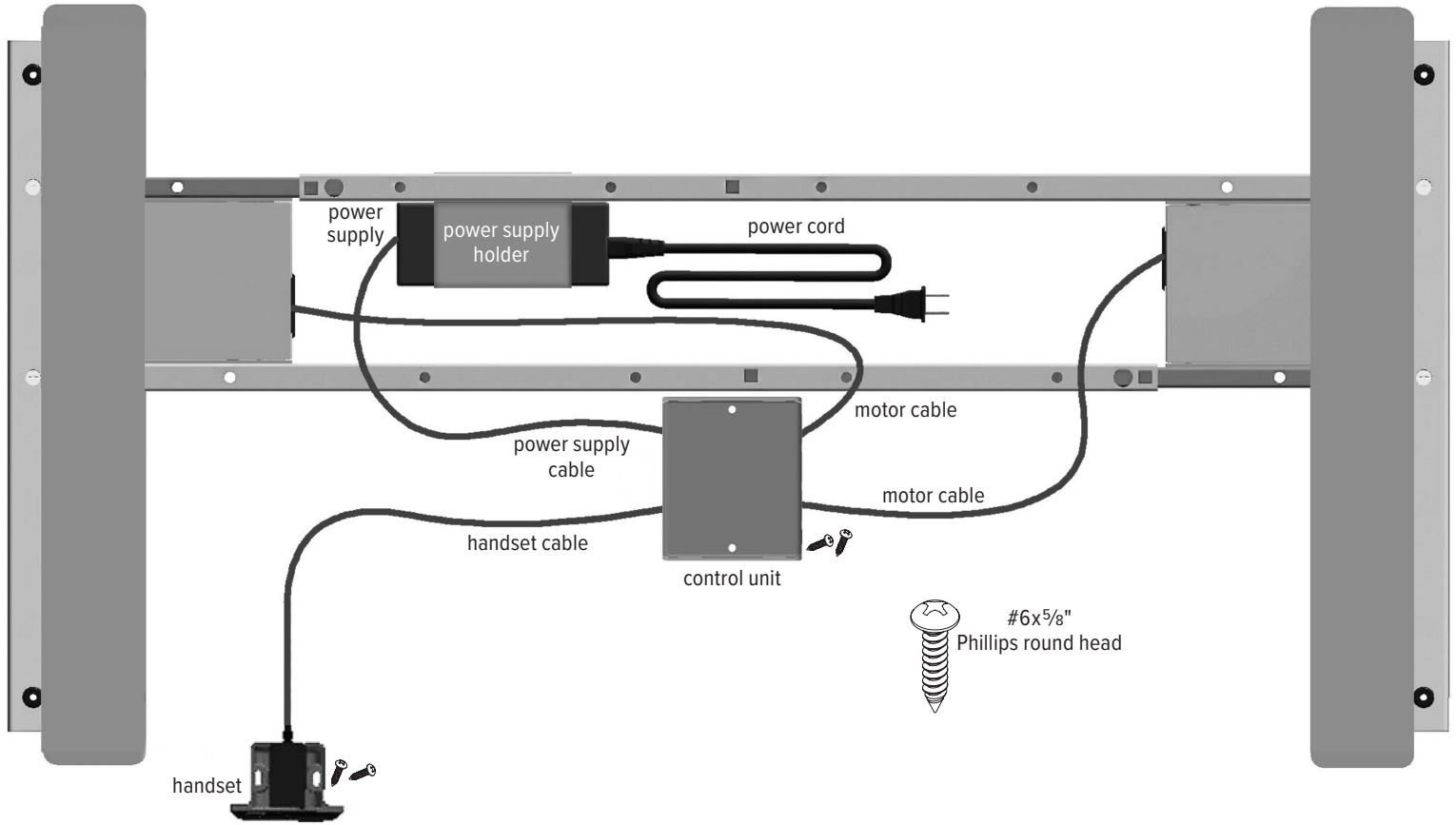

### Step #9: attach handset

- Position the handset on either side of the table (user preference). **NOTE:** With the table face-down, the left side will be the right side when the table is turned upright.
- Position the handset so that the controls are flush with the front edge of the table.
- Attach the handset using two #6x5/8" Phillips round head screws.

### Step #10: attach control unit

- Position the control unit in front of the front crossbar, approximately centered on the worksurface from side-to-side.
- Attach the control unit using the two #6x5/8" Phillips round head screws.

### Step #11: attach power supply

- Fit the power supply into the power supply holder.
- When the table is turned upright, the power cord end should be the end closest to the nearest AC outlet.

### Step #12: make cable and cord connections

- Connect the cable from the handset to the control unit.
- Connect the motor cables from the legs to the control unit.
- Connect the cable from the power supply to the control unit.
- Connect the power cord to the power supply.
- Plug the power cord into an AC outlet. Be sure the cord will be able to reach the outlet when the table is raised to its highest position.

**CAUTION:** Do not operate the table until after initializing the system. See the following step.





### Step #13: initialize the table and test operation

- Press the DOWN ▼ button to move the legs to their lowest position. This initializes the table and makes it ready for operation.
- Test operation by pressing the UP ▲ and DOWN ▼ buttons individually to move the legs to their fully extended and fully compressed positions.
  - End your test with the legs lowered.
  - Unplug the power cord.
- If there is a problem with operation, check that all cable and cord connections are secure. Check to be sure the AC outlet has power. If problems continue, call ESI Customer Service: 800.833.3746.

**NOTICE:** With the table upside-down, the DOWN ▼ button points up and the UP ▲ button points down.

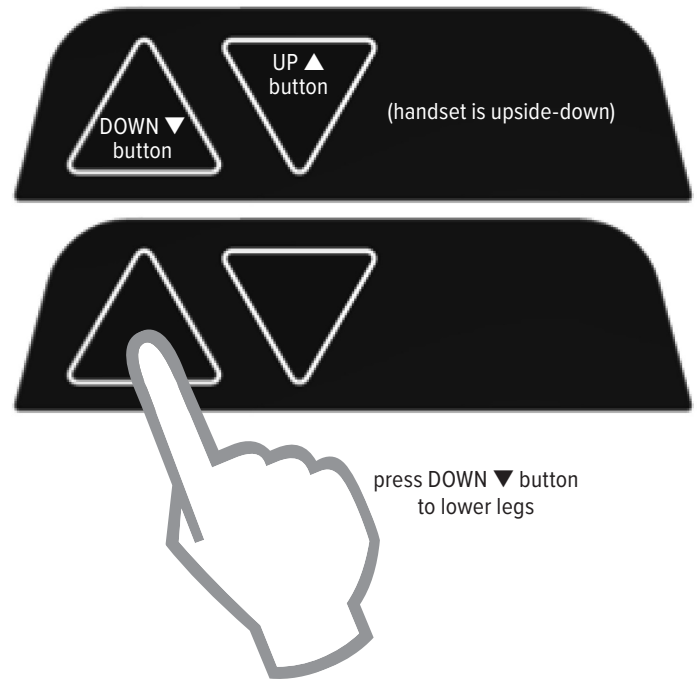

### Step #14: use cord clips to secure cables and cords

**CAUTION:** The cables and cords must not dangle under the table where they may present a hazard to the user or may accidentally be pulled from their connections.

- Place the cord clips onto the cables and cords.
- Use the #6x5/8" Phillips round head screws to fasten the cord clips to the table.

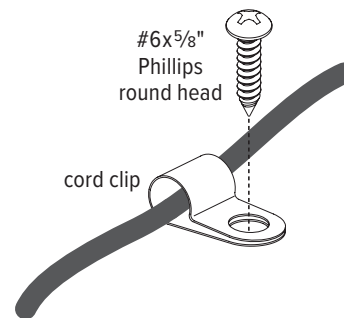

### Step #15: turn the table upright



**WARNING:** Lifting hazard. Single person lift could cause injury. Use assistance when moving or lifting.

- With the assistance of a helper, turn the table upright and place it in its final position. **IMPORTANT:** There must be 1.0" (25mm) of clearance on all sides of the worksurface (and other moving parts) to ensure free, unobstructed movement.
- If necessary, adjust the leveling glides on the feet to level the worksurface.
- Plug the power cord into an AC outlet.
- Press the DOWN ▼ button to move the table to its lowest position. **IMPORTANT:** Be sure there are no obstacles under the table that would prevent it from reaching its lowest position.
- See the following pages for operating procedures.

**NOTICE:** Whenever the unit is unplugged or the power is cut, the table must be re-initialized by pressing the DOWN ▼ button to move the table to its lowest position.

## general operation

- Move the table by pressing the UP ▲ button to raise it and the DOWN ▼ button to lower it.
- The table will continue to move up or down until you release the button, until the maximum or minimum height is reached, or until a memory stop is reached.

*Table movement stops when you release the button.*

**NOTE:** The table must stop prior to reversing directions.

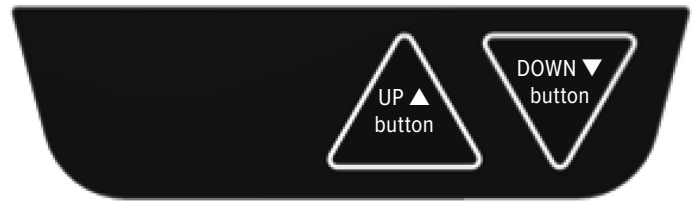

## memory stop positions

Upper and lower memory stop positions can be used to save specific heights of the worksurface. To set a specific position:

- Raise or lower the table to the first position you want to save.
- Press the UP ▲ and DOWN ▼ buttons simultaneously, and release.
- Repeat three times, waiting ½ to 1 second between each pressing.
- Then press the UP ▲ button to set the upper limit or the DOWN ▼ button to set the lower limit.
- Repeat to set the second limit.

*After setting each limit, the table will do a gentle rise to confirm the setting.*

To move the worksurface to a memory stop position:

- Press the UP ▲ or DOWN ▼ button until the table stops. Release the button.
  - If you continue to press the UP ▲ or DOWN ▼ button for five seconds after the table stops, the table will continue to move up or down.

*If you release the memory button before the saved position is reached, table movement will stop.*

To delete the memory stop positions:

- Perform a manual reset by pressing the UP ▲ and DOWN ▼ buttons simultaneously for seven seconds.
- Then press the DOWN ▼ button to move the table to its lowest level.

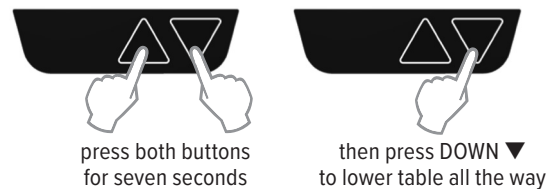
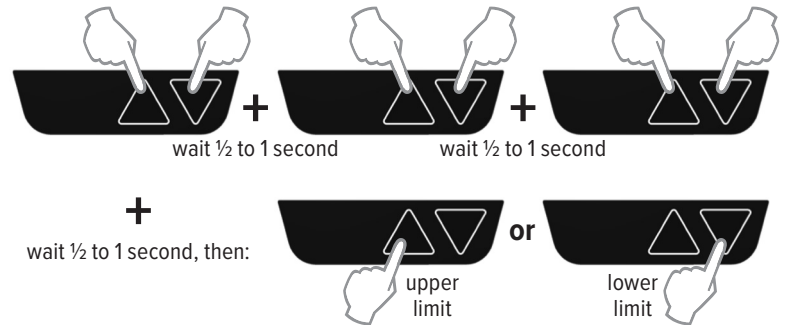





# Trada™ 2-Leg

Electric height adjustable table base

Please contact Customer Service with any questions or comments at 800.833.3746 or visit our website at [esiergo.com](http://esiergo.com)

## LIMITED WARRANTY

ESI warrants this product to be free from defects in manufacturing for a period of 15 years on structural parts and 7 years on electrical parts from the date of original purchase. This warranty extends only to the original purchaser, and does not apply if the product has been damaged or fails to function properly as a result of misuse, abuse, modification, alteration, or improper cleaning or maintenance. This warranty does not apply to damage in shipment caused by carriers, damage caused during installation, normal wear and tear, or excessive use (meaning consistent use in excess of an eight hour shift). ANY IMPLIED WARRANTIES OF MERCHANTABILITY OR FITNESS FOR A PARTICULAR PURPOSE ARE LIMITED IN DURATION TO ONE YEAR FROM THE DATE OF ORIGINAL RETAIL PURCHASE. ESI's sole obligation under this warranty or any implied warranty, and the purchaser's sole remedy, is limited to the repair or replacement, at ESI's option, of the product or any defective part. Costs (such as installation or express shipping) incurred due to replacement of products are not covered under warranty. IN NO EVENT SHALL FELLOWES, ITS AFFILIATES, SUBSIDIARIES, RELATED ENTITIES OR THEIR RESPECTIVE OFFICERS, DIRECTORS, OR EMPLOYEES, BE LIABLE FOR INCIDENTAL, CONSEQUENTIAL, PUNITIVE, EXEMPLARY, OR SPECIAL DAMAGES.

To make a warranty claim, contact ESI at 800-833-3746 or [customerservice@esiergo.com](mailto:customerservice@esiergo.com). You must provide proof of purchase, such as the original purchase order number.

The duration, terms and conditions of this warranty are valid worldwide, except where different limitations, restrictions or conditions may be required by local law.