

**3C** Active back control user guide.

Standard control on the Brisbane & Terra series.

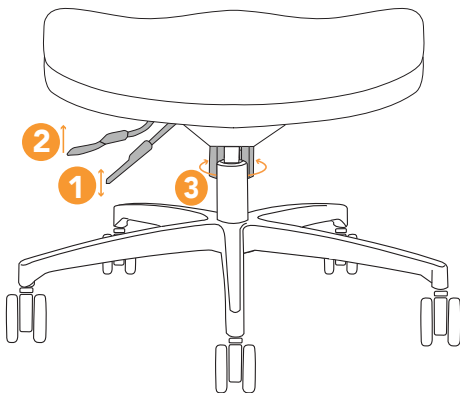

**1** Seat height adjustment - Adjust the seat height by lifting your weight out of the chair and pulling up on the paddle. Proper seat height is realized when the top of your legs are somewhat parallel to the floor.

**2** Back lock adjustment (5 position) - Pull lever upward and shift your weight forward or back to desired angle. Release lever to lock. To free float the back, pull lever upward until locked

**3** Back/recline tension adjustment - Rotate knob right to increase tilt tension. Rotate knob left to decrease tilt tension.



**Contract Holder**

contract #: GS-28F-005CA

contractor: VIA INC