

35C Auto-adjust body balance stool control.

Latest body balance technology.

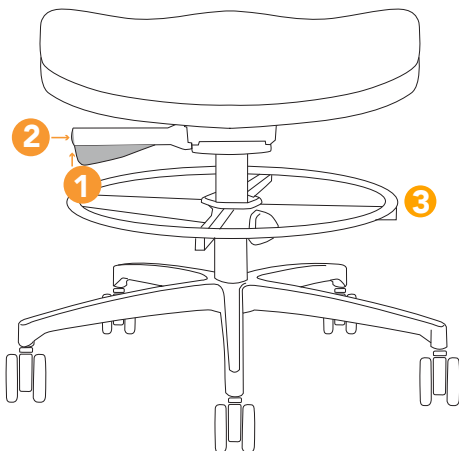

1 Seat height adjustment - Adjust the seat height by lifting your weight out of the chair and pulling up on the paddle. Proper seat height is realized when the top of your legs are somewhat parallel to the floor.

2 Back lock adjustment (single position) - Use the same paddle you used for the seat height adjustment. To lock the chair shift your weight forward until the chair is in an upright position, then push the button in. To rock (free float) shift your weight forward and push the button again.

3 Foot ring height adjustment (for **-11DR** or **-11XDR**) - Press down on the plastic inner hub and lift the foot ring up to unlock. Adjust to desired position. To lock, press down on the outer foot reset until hub is in locked position.



Contract Holder

contract #: GS-28F-005CA

contractor: VIA INC