

Owners Manual

MT-10SV

432-010-V

MINI-SONIC Vibratory Tumbler



IMPORTANT SAFETY INSTRUCTIONS

PLEASE READ BEFORE OPERATING THIS MACHINE

Before plugging in this machine, make certain the electrical outlet is properly grounded and of the proper voltage. Also make certain that the machine switch is off and that your hands and the electrical connections are dry in order to avoid possible electrical shock.

Using the Mini-Sonic MT-10SV Tumbler

Congratulations on selecting the Mini-Sonic MT-10SV electronic vibratory tumbler. You have a tumbler that is easy to use, is virtually maintenance free, and is made to give you long-lasting service.

The MT-10SV will tumble polish almost any type of stone, from opal to topaz, and metal items such as coins, shell casings, jewelry findings, etc.

Most of the procedures described in this manual are for tumbling stones. Tumbling metal objects is done basically the same way, except the abrasive and filler materials are different, depending on the type of metal. For further information please contact our Customer Services Department.

Principle of Operation

Your Mini-Sonic vibratory tumbler operates on a unique principle employing vibration as the driving force which powers the rotation of the load inside the tumbler hopper. During rotation, the tumbling load is alternately separated and compacted during each vibratory cycle. This

improves the tumbling process and allows fresh abrasive to be drawn in between materials in the tumbler hopper. Only the contents inside the hopper actually rotate while the hopper itself remains practically motionless except for the driving arc of motion.

Only a small amount of abrasives are required in the Mini-Sonic tumbling process compared to ordinary rotary tumblers. As the abrasive begins to pulverize or break down and combines with rock dust and water, a slurry or coating mixture is formed, and it is this coating which should be maintained throughout all the tumbling processes. Too much water or too much abrasives will cause materials to collect in the bottom of the hopper and not rotate properly. It is only necessary to maintain a thin coating of abrasive slurry between the materials in the load to keep the polishing process working properly.

Operation and Maintenance

The Mini-Sonic tumblers operate without shafts, belts, pulleys, eccentric weights or even a motor - no moving parts so that they will outlast other types of tumblers. The tumbler housing is durable ABS plastic, long lasting and easy to keep clean. The hoppers are cast polyvinyl and will last for thousands of tumbling hours.

Operating frequency is in excess of 3,500 vibrations per minute. Rotation and intensity is adjustable with solid state electronic controls. The control knob also serves as the On-Off switch. Turn clockwise to start unit and select desired degree of operation for the materials being processed. Turn counter-clockwise for the Off position.

The MT-10SV tumbler is relatively quiet in operation when loaded. You can decrease the vibration noise even more by setting the machine on a piece of old carpet when in operation.

Removing and Replacing the Hopper

The hoppers are designed to fit tight in their clips in order to insure proper vibratory action while in operation. It is held in place by a lug molded into the hopper that fits into a hole in the clip rear, and by a rubber latch that attaches to the clip at the front of the hopper.

To Remove the Hopper:

1. Leave the lid attached in order to prevent contents of hopper from splashing out.
2. Unhook the rubber latch(s) from the hopper clip.
3. Grasp the hopper firmly and roll it towards the rear of the clip so that the lug slips from the clip hole.

Do Not attempt to remove the hopper by twisting or by any method other than described above as you can damage the unit.

To Replace the Hopper:

1. Place the hopper into the clip so that the lug will slip into the hole in the clip rear.
2. Roll the hopper towards the front of the clip until it is properly seated.
3. Attach the rubber latch to the front clip.

Selecting Materials for Tumbling

Select your materials with care. The better the quality of the stones used, the better the final polish will be obtained. Do not expect poor or

inferior materials to be transformed by some miracle into beautiful and precious gems. Most materials ranging in hardness of 5 on the Mohs scale up through 8, may be processed by the tumbling method. Extremely hard and extremely soft stones usually require special treatment, and should not be mixed with other materials. Beginners should start with agates, jaspers, and stones of similar hardness, about 6.5 to 7.5, as these stones are relatively easy to polish to a beautiful shine.

To determine the approximate hardness of rocks collected in the field, refer to the Mohs scale and scratch test guide given below. Use of this guide allows one to make quick, relative determinations of a stone’s hardness which is useful not only in selecting material suitable for tumbling, but also helps in identifying the particular rock or mineral.

Mohs Hardness Scale

MINERAL	HARDNESS	COMMON TESTS
Talc	1	Scratched by fingernail
Gypsum	2	
Calcite	3	Scratched by copper coin
Fluorite	4	Scratched by a knife blade or window glass
Apatite	5	
Feldspar	6	Scratches a knife blade or window glass
Quartz	7	
Topaz	8	
Corundum	9	
Diamond	10	Scratches all common materials

The size of the stones should be varied rather than similar. Generally, most of the load should measure from three quarters of an inch to one and one half inches, with a few stones up to two inches. The size variance prevents the stones from forming a relatively solid mass which will not process properly.

Fillers

A filler or media of some type should be used to close airspaces between the rough stones. Fillers such as ceramic media, plastic pellets, ground corn cob and walnut shells are available. We recommend the use of ceramic media. Fillers help cushion the rocks and also distribute the abrasives more thoroughly through the load. In most cases the fillers may be re-used for subsequent loads.

Tumbling Instructions

The basic principle of tumble-polishing stones is to start with a coarse abrasive and work through a series of progressively finer abrasives until the desired polish or finish is achieved. At each step, enough time must be spent so that no further improvement in the stone’s finish can be seen using that particular grit. The amount of time necessary for each step varies depending on the material being tumbled and the abrasive being used. In general, more time must be spent on the first, coarser grit steps and less on the following or finer grit steps. Two to three weeks is average for a load of agate stones.

Tumble polishing stones is not an exact science, and anyone doing a lot of tumbling soon develops his/her own methods and grit sequences for polishing different types of stones. You will too, but the following instructions will serve as a guideline and give good results.

Preparation:

Set your tumbler on a firm, level surface preferably in an area where the noise of the tumbling rocks will be less of a bother. Setting the machine on a piece of carpet helps to deaden the noise.

Select your material for similar hardness and for quality so that results will be pleasing. Vary the size of pieces from about 3/4" to 1-1/2" with one or two stones up to 2" in size.

Wash your rocks in hot, sudsy water. Rinse them well and let them drain a bit. When the rocks are still damp but not dripping you are ready to get started. **REMEMBER: Always be sparing with water, add just one teaspoon at a time.**

(Quantities in following steps are for 4 lb hoppers, adjust accordingly for larger hoppers.)

Step 1: Coarse Grind (60/90 Grit Silicon Carbide)

- a Put about two pounds of your rocks into the hopper or about 1/2 full. Turn on tumbler, **MAKING CERTAIN YOUR HANDS ARE DRY BEFORE USING THE ELECTRICAL CONNECTION.**
- b Add enough filler to bring the load up to about 2/3 full. Add 6 level teaspoons of the 60/90 grit. Let the load mix well. At this time you may be able to add more stones, but the load should never reach above 2 inches from the top of the hopper.
- c Check the tumbling action. The rocks should be vibrating in towards the center of the hopper and going under, something like the action of a washing machine. If you are not getting the right tumbling action or it is slow, you may have to add a little more water. (Anytime you can see water, you have too much.) Other problems may be too large a load, or too small, or you may need a greater variance in the size of the rocks.

- d Replace the tumbler lid to prevent evaporation of water and to reduce the noise. To help retain moisture, place a plastic bag or some plastic wrap over the hopper and replace the lid.
- e The coarse grind will be the longest and takes from 4 to 5 days. The load should be checked two to three times daily because of the build-up of mud (ground up rock and grit) which can cause the action of the tumbler to slow down. A small amount of water may be added to restore the action.
- f In this first step you are mostly trying to smooth the surfaces of the stones. When no further improvement results, wash and clean the rocks, filler and hopper thoroughly. **DO NOT wash where there is a drain as the mud and grit can clog the drain.** On a lawn is a good place for the washing process. Wash the stones, filler and hopper well, as even one particle of grit left on a stone or in the barrel can scratch the finish of the finer grits.

Step 2: Fine Grind (220 Grit Silicon Carbide)

- a Return clean, damp stones and filler to tumbler and turn on machine.
- b Sprinkle in about 5 level teaspoons of the fine grind 220 grit. This step will take from 3 to 4 days. In this step you are trying to achieve a dull finish.
- c Follow the general instructions "c" through "f" in Step 1 above.

Step 3: Sanding (600 Grit Silicon Carbide)

- a Return clean, damp stones and filler to tumbler and turn on machine.
- b Sprinkle in about 4 level teaspoons of the 600 grit silicon carbide. This step will take from 2 to 3 days. In this step you are trying to achieve a shine when the stones are wet.
- c Follow the general instructions "c" through "f" in Step 1 above.

Step 4: Pre-Polish (600 or 800 Grit Aluminum Oxide)

previous grit. Add load to tumbler hopper.

- b Sprinkle in about 2 level teaspoons of aluminum oxide grit. This step will take about 1 to 3 days. On stones of 7 in hardness, you will probably achieve a satisfactory polish, but for a really high polish, go to Step 5 when you are finished with Step 4.
- c Follow the general instructions “c” through “f” in Step 1 above.
- d Separate out the filler and set it aside for the next batch of stones.

Step 5: Polish

- a Make certain your stones and hopper are clean of all previous grit. Add clean stones to the tumbler and add enough unused filler to fill up the spaces between the stones. Turn on tumbler.
- b Sprinkle in about 2 level teaspoons of polish. This step will take from 1 to 2 days and will put a high shine on most stones.
- c Follow the general instructions “c” through “f” in Step 1 above.
- d For a final clean-up, you may wish to run the stones for a few hours in a solution of laundry detergent and enough water to make thick suds. This will clean off any remaining polish and do a final burnishing job on the stones.

Thank You

For your purchase of a [Diamond Pacific](#) Mini-Sonic Tumbler. Should you require additional supplies, parts or technical assistance please contact our Customer Services Department. Our business hours are Monday through Friday from 8:00 am to 5:00 pm Pacific time.

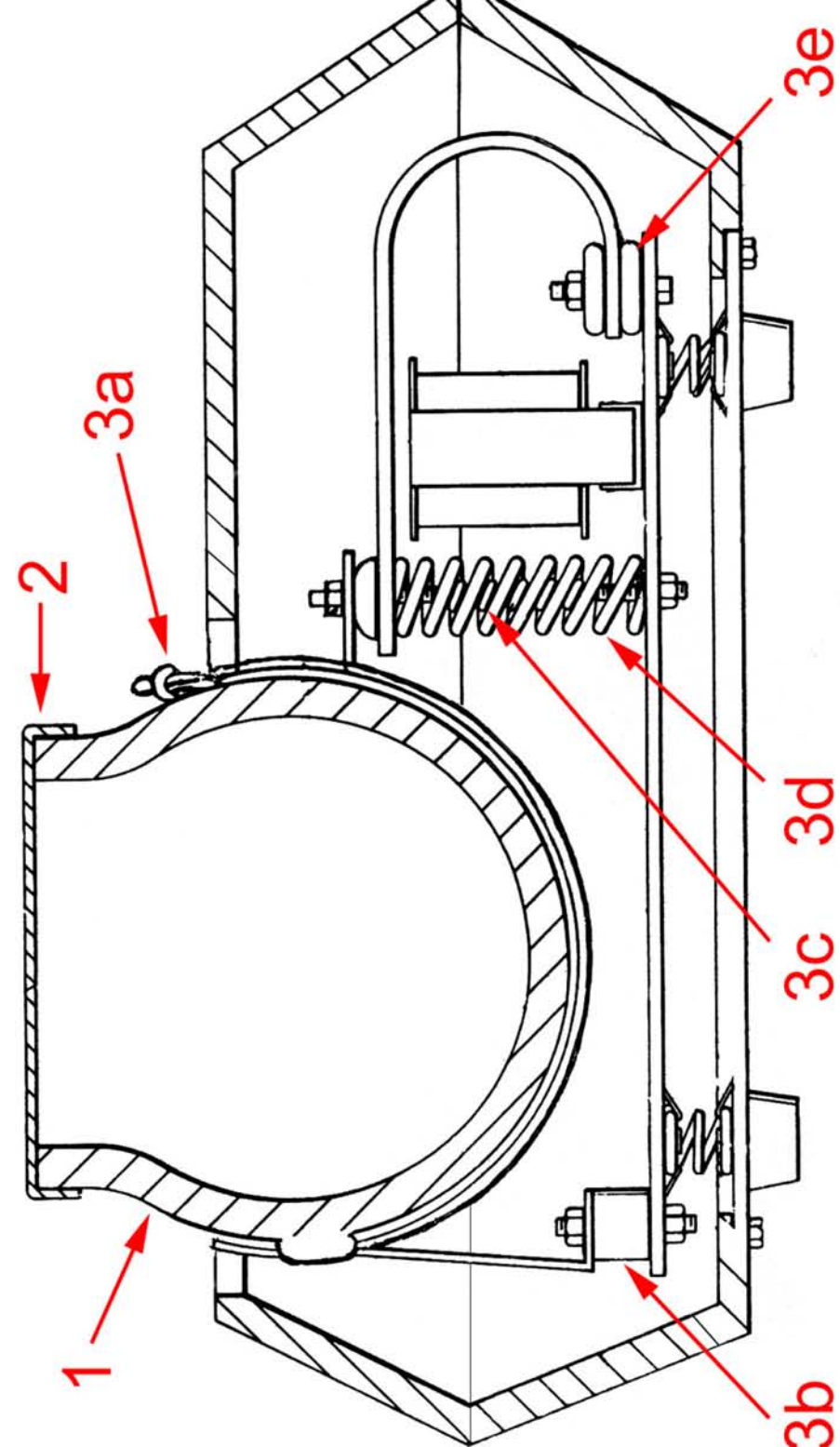

Replacement Parts

Key #	Description	Order #
1	Replacement Hopper (includes lid)	433-04H (4lb) 433-10H (10lb)
2	Replacement Lid	433-04L (4lb) 433-10L (10lb)
3	Tune-up Kit ** (Requires 2)	490-402097

The model and serial numbers of your tumbler can be found on a label on the bottom side of your tumbler. You may want to write both numbers in the spaces provided below for easy reference.

Model # MT-10SV

Serial # _____

** Item #3 "Tune-up Kit" includes the following:

- 3a. Hopper latch with pop rivets.
- 3b. Isolator (2).
- 3c. Extension Spring (inner).
- 3d. Compression Spring (outer).
- 3e. Rubber Grommet (3).





S U V A
LAPIDARY SUPPLY

DIAMOND WHEELS
PIXIE COLLECTION
GENIE COLLECTION
TITAN COLLECTION
CABBING SUPPLIES
CARVING SUPPLIES
TUMBLING SUPPLIES

