



Titanium Edition

Titanium Edition EcoChlor Saltwater Chlorine Generator Installation and Operation Manual



**Titanium Edition EcoChlor
Saltwater Chlorine Generator
Installation and Operation Manual**

1.0	INTRODUCTION	4
2.0	GETTING STARTED	4
3.0	SAFETY INFORMATION.....	4
4.0	THE CHEMISTRY INVOLVED.....	5
5.0	WATER CHEMISTRY	5
6.0	ADDING SALT TO POOL OR SPA.....	7
7.0	INSTALLATION	9
8.0	INSTALLATION CHECKLIST	12
9.0	OPERATION	13
10.0	MAINTENANCE.....	17
11.0	TROUBLESHOOTING.....	19
12.0	WARRANTY	22

1.0 INTRODUCTION

- 1.1.1 Congratulations on your recent purchase of a Titanium Edition Eco Chlor Saltwater Chlorine Generator. Please take a moment to read through the entire manual before installing your new unit. Your generator must be installed and operated as specified.

2.0 GETTING STARTED

- 2.1.1 **READ THIS FIRST.** As with any electrical device it is very important that the installation and service of this equipment be performed by a qualified person with the skills and experience required to do it safely and correctly. Improper installation or service can result in severe electrical shock to the installer or user of the equipment or pool. Please choose your installer with great care.

3.0 SAFETY INFORMATION

3.1 IMPORTANT SAFETY INSTRUCTIONS, READ AND FOLLOW ALL INSTRUCTIONS. SAVE ALL INSTRUCTIONS.

- 3.1.1 **i WARNING:** To reduce the risk of injury, do not permit children to operate this device.
- 3.1.2 **i WARNING:** To reduce the risk of electric shock, fire or injury, service of this device should only be attempted by a qualified professional.
- 3.1.3 **i WARNING:** Chemical Hazard - When mixing acid with water, always add the acid to the water, never add water to the acid. When using the acid ensure to use rubber gloves and appropriate eye protection.
- 3.1.4 Heavy pool (and/or spa) usage, and higher temperatures may require higher chlorine output to maintain proper free available chlorine residuals.
- 3.1.5 Do not add chemicals directly to the skimmer as this may damage the cell.
- 3.1.6 If additional chlorine is required due to heavy bather loads, use Sodium Hypochlorite to maintain an appropriate chlorine residual in the water. For outdoor pools, chlorine residuals can be protected from destruction by sunlight by addition of stabilizer (cyanuric acid).
- 3.1.7 Maintaining high chlorine and very high salt levels above the recommended range may contribute to corrosion of pool (and/or spa) equipment.
- 3.1.8 Check the expiration date of any chemical test kits as test results may be inaccurate if used after that date.
- 3.1.9 When replacing the cell, only use replacement cells having a label that clearly states that it is a replacement cell for this model.

3.1.10 For proper sanitation, spas must be completely drained periodically. The number of days between complete spa drainage is equal to the volume of the spa water in gallons, divided by 10 times the maximum number of daily spa users. Refill spa with water and repeat directions of use of this device.

3.2 Health and Hyperthermia Warnings for Spa Devices

3.2.1 **ⓘ WARNING:** People with a medical condition should consult a physician before entering pool or spa water.

3.2.2 **ⓘ WARNING:** Maximum spa water usage temperature is 40c. Bathing time in spa water at 104°F should not exceed 15 minutes.

4.0 THE CHEMISTRY INVOLVED

4.1.1 The Titanium Edition chlorine generator by electrolysis creates chlorine to sanitize your pool using the salt molecules (NaCl) in your water. A small electric charge is applied across a set of titanium plates inside the Electrolytic Cell. This produces Sodium Hypochlorite (NaOCl). In water, Sodium Hypochlorite dissociates into sodium (Na+) and hypochlorite (OCl-) ions.

4.1.2 It is the hypochlorite ions that form with the hydrogen (H+) ions (from the water) to form hypochlorous acid (HOCl), which is the active agent that destroys bacteria and algae, and oxidizes organic matter. This form of chlorine works quickly in the pipe, leaving only a mild residual in the pool.

5.0 WATER CHEMISTRY

5.1 **WARNING:** Prior to turning on your Titanium Edition Chlorine Generator for the first time (including reopening your pool for the new pool season) your water chemistry must be balanced according to the following guidelines.

5.2 Recommended Salt and Pool / Spa Chemistry Readings

	Swimming Pools	Spas
Free Available Chlorine	1.0 – 3.0 ppm	3.0 – 5.0 ppm
pH	7.2 – 7.8	7.2 – 7.8
Total Alkalinity	100 – 120 ppm	100 – 120 ppm
Calcium Hardness	200 – 300 ppm	150 – 200 ppm
Stabilizer (Cyanuric Acid)	30 – 60 ppm	30 – 60 ppm
Total Dissolved Solids	< 1,200 ppm	< 1,200 ppm
Salinity	3000 – 4000ppm	3000 – 4000ppm

- 5.2.1 **Chlorine Stabilizer (Cyanuric Acid).** Chlorine Stabilizer is needed to maintain proper levels of chlorine. Unstable chlorine can be destroyed by the sun's UV radiation within two hours. Chlorine stabilizer must be maintained between 30 – 60 ppm.
- 5.2.2 **Nitrates and Phosphates.** These chemicals can cause extremely high chlorine demands and will deplete chlorine from your pool. In some cases, they may even lower your chlorine levels to zero. Your local pool professional can test for Nitrates and Phosphates and recommend methods of removal.
- 5.2.3 **Metals.** Metals can cause loss of chlorine. Also, metals can stain your pool and tint your water. Have your local pool professional check for metals and recommend methods of removal.
- 5.2.4 **Chloramines.** Chloramines should not be present in pool water. When organic materials are not fully oxidized by Free Chlorine, Chloramines are formed. This ties up the Free Chlorine in your pool, and does not allow the chlorine in your pool to disinfect. Chloramines also cloud pool water and burn the eyes. Shock the pool with chlorine to remove Chloramines at the initial start up of the pool.
- 5.2.5 **pH Levels.** pH produced by a chlorine generator is close to neutral pH. However, other factors usually cause the pH of the pool water to rise. Therefore, the pH in a pool chlorinated by a chlorine generator tends to stabilize at approximately 7.8. This is within national standards. If the pool pH rises above 7.8, have a pool professional test to see if other factors such as high Calcium Hardness or Total Alkalinity are the cause, and then balance accordingly.
- 5.2.6 **Total Dissolved Solids (TDS).** Adding salt to pool water will raise the TDS level. While this does not adversely affect the pool water chemistry or clarity, the pool water professional testing for TDS must be made aware that salt has been added for a chlorine generator system. The individual performing the TDS test will then subtract the salinity level to arrive at the correct TDS level.

5.3 Water Chemistry Helpful Hints

- 5.3.1 Proper operation of the chlorine generator can be easily verified by inspecting the Electrolytic Cell. The chlorine being produced will appear as a fog at one end of the plates.
- 5.3.2 If the pool remains cloudy, or the chlorine residual tests low, then the chlorine being produced is being lost due to high chlorine demand or improper water conditions. Take a water sample to a pool professional to ensure that the pool water is balanced correctly.

5.4 Recommended List

- 5.4.1 Read and keep your manual in a safe place.
- 5.4.2 Increase chlorine production when temperature goes up.
- 5.4.3 Increase chlorine production when number of guests go up.
- 5.4.4 Use Stabilizer (Cyanuric Acid) to protect free chlorine in pool
- 5.4.5 Decrease chlorine production when temperature goes down.
- 5.4.6 Take pool water sample to a Pool Professional once per month.

5.5 Not Recommended List

- 5.5.1 Do not allow fertilizer anywhere near your pool. Fertilizers contain Nitrates or Phosphates which cause severe chlorine demand in pool water.
- 5.5.2 Never use dry acid to adjust pH. A build up of by-products can damage the Electrolytic Cell.
- 5.5.3 Do not add any pool water balancing chemicals (including salt) unless the Power Unit is turned off.
- 5.5.4 Do not add any chemicals (including salt) to the skimmers.
- 5.5.5 Do not let salinity level drop below 3000 ppm.

5.6 Definitions

- 5.6.1 **Algae.** Plant-like organisms which grow in water. Especially active in summer conditions, where chlorine disinfectant level is too low to destroy them. Algae may be green, yellow, brown or black (Black Spot) in color.
- 5.6.2 **Chlorine Demand.** The amount of chlorine that should be added to the water to provide proper bacteria and algae control.
- 5.6.3 **Chlorine Residual.** The amount of chlorine left over, after the “demand” has been met.
- 5.6.4 **Combined Chlorine.** Weak chlorine which is combined with the contaminants in the water.
- 5.6.5 **Free Chlorine.** Active chlorine in the water with the potency to destroy contaminants.
- 5.6.6 **Shock Treatment.** The removal by means of oxidation of those materials that have chlorine demand.

6.0 ADDING SALT TO POOL OR SPA

6.1 Adding Salt

- 6.1.1 DO NOT add pool/spa chemicals directly to the skimmer. This may damage the cell. Maintaining high salt levels above the recommended range can contribute to corrosion of pool/spa equipment. If the chlorine generator has already been installed, it must be turned off before adding salt. The recommended salt concentration for the Infinity Series is 3500 ppm.
- 6.1.2 For pools it is best to empty the required salt into the shallow end of the pool and run the filter and pump simultaneously while the Infinity Series chlorine generator is off to circulate the water and dissolve the salt. Do not throw the salt bag into the pool or spa as chemicals and inks on the bag can interfere with the water balance.
- 6.1.3 Salt may take 24 – 48 hours to dissolve in the summer and longer in the winter. Finer granules of salt will dissolve faster than compressed pellets.

6.2 Type of Salt to Use

- 6.2.1 The more pure the salt the better the life and performance of the electrolytic cell. Use a salt that is at least 99.8% pure NaCl. The preferred salt is an evaporated, granulated, food quality, non-iodized salt. Consult your local pool store.
- 6.2.2 Avoid using salt with anti-caking agents (sodium ferrocyanide, also known as YPS or yellow prussiate of soda) that could cause some discolouration of fittings and surface finishes in the pool.
- 6.2.3 Water conditioning salt pellets are compressed forms of evaporated salt and may be used but will take longer to dissolve.
- 6.2.4 Do not use calcium chloride as a source of salt (use sodium chloride only).
- 6.2.5 Do not use Rock salt. Insoluble impurities mixed with the rock salt can shorten the life of the Cell Module.
- 6.3.1 The Compu Pool Infinity Series chlorine generator can work with a broad salinity range, from a minimum of 3000 ppm (parts per million), up to 8000 ppm. However, the ideal level for operation is 3500 ppm. To achieve this level of salinity, add 3.5 kgs of salt for every 1000 litres of water. If you are unsure of the number of litres in your pool, double-check with the equations below.

6.3 Salt Level

- 6.3.1 The Compu Pool Infinity Series chlorine generator can work with a broad salinity range, from a minimum of 3000 ppm (parts per million), up to 8000 ppm. However, the ideal level for operation is 3500 ppm. To achieve this level of salinity, add 3.5 kgs of salt for every 1000 litres of water. If you are unsure of the number of litres in your pool, double-check with the equations below.

	Litres (Measurements in Metres)
Rectangular	Length x Width x Average Depth x 1000
Round	Diameter x Diameter x Average Depth x 775
Oval	Length x Width x Average Depth x 775

- 6.3.2 If the salt level is low, determine the number of litres in the pool and add salt according to the chart below. A low salt level will reduce efficiency of the chlorine generator and result in low chlorine production. A high salt level can cause a salty taste to your pool and may damage pool equipment. In addition, operating the unit outside the recommended salt range will rapidly reduce the longevity of the cell. The salt in your pool/spa is constantly recycled and the loss of salt throughout the swimming season should be small. This loss is due primarily to the addition of extra water to replace water lost from splashing, backwashing, and draining (because of rain). Salt is not lost due to evaporation.
- 6.3.3 If salt content is too high you will need to reduce the level of water in your pool/spa and refill the pool/spa with fresh water that has not been diluted with salt.
- 6.3.4 To initially start a pool with the correct amount of salt, add salt to the pool at a rate of 35 kgs of salt for every 10 thousand litres of water

7.0 INSTALLATION

7.1 Overview

- 7.1.1 The Power Module is to be mounted at least 3 feet above ground level, and if possible protected from direct weather. The Cell Module is to be plumbed into the return line to the pool after the pump and filter and heater, if applicable (see Figure 1). The Cell Module has a 15 feet cable to connect to the Power Module. The Power Module must be installed 10 feet or more away from the pool edge.

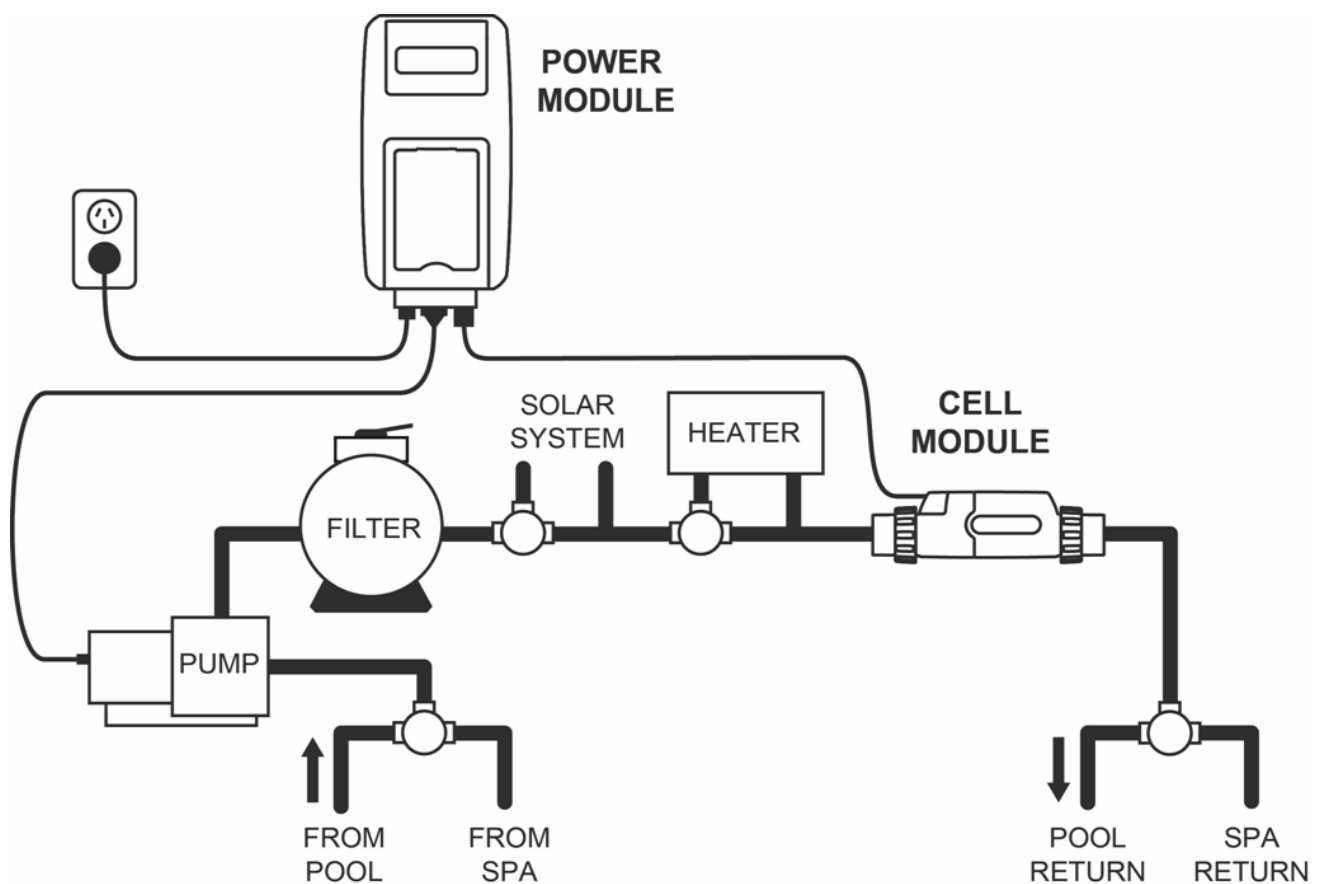

7.1.2 **Figure 1** - Installation Schematic.

7.2 Wiring

- 7.2.1 The Power Module comes with a standard 240VAC 10Amp power cable that is to be connected to mains power. Plug the power cable into a suitable weatherproof outlet.

7.3 Installing the Power Module

- 7.3.1 Mount the Power Module as close to the pump and filtration system as possible. Make sure the Cell Cable (4.6m) can reach the section of pipe selected for the cell. **Do not install the Power Module within 3 meters of the pool edges.**
- 7.3.2 Using the supplied screws and anchors, secure the Mounting Bracket at eye level to the wall or support. Once the Mounting Bracket is tightly secured, lift the Power Using the provided screws and anchors, secure the Mounting Bracket at eye level to the wall or support. Once the Mounting Bracket is tightly secured, lift the Power Module onto the Mounting Bracket and secure with the provided screws.

7.4 Installing the Cell Module

- 7.4.1 Be sure the pool pump is turned off.
- 7.4.2 The Cell is to be fitted into the return line to the pool after the pump, filter and heater (if applicable). Water flow should come from the filtration system through the inlet closest to the Cell Cable and back out through the opposite outlet.
- 7.4.3 The orientation of the Cell in the plumbing is critical for the function of the unit. Please refer to Figure 5 for available plumbing configurations.

The Titanium Edition Cell can be installed in any manner as long as the top side of the housing is facing upwards as shown in all of the plumbing scenarios below:



The Titanium Edition Cell cannot be installed vertically, except in the plumbing installation shown below with the cable to the top and with a gas trap created immediately above the cell. This installation is not recommended and should only be implemented when there is no other option.

If this installation is required, the elbow must be installed below the dotted line shown in the illustration as the top half of the cell is where the water sensor is located.

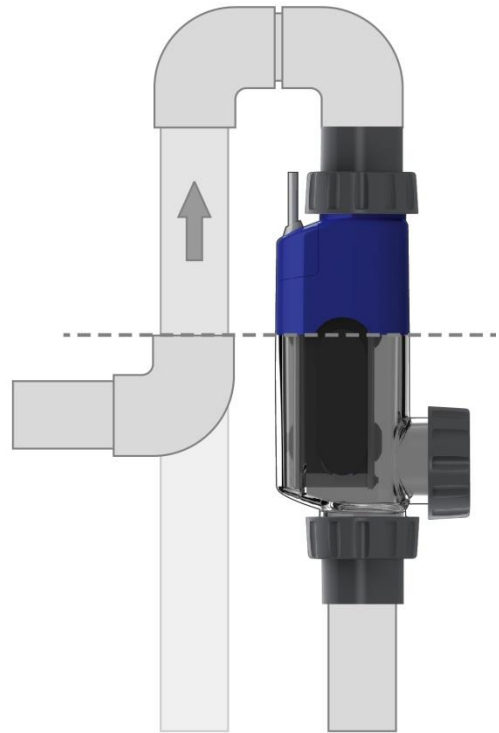

GROUND

7.4.4 **Figure 5 - Cell Installation Options.**

-
- 7.4.5 Make sure that the 4m Cell Cable reaches from the Power Module to the area where you will be installing the Cell.
 - 7.4.6 The Cell Module comes with Unions to connect to the filtration plumbing. These Unions enable the Cell to be easily removed for cleaning etc. The Unions are sized to take 50mm pipe, if a 40mm pipe connection is required, reducers will need to be fitted.
 - 7.4.7 To install the Unions cut out a 35cm section of pipe out of the desired installation location. Use plumbing Cleaner Primer to clean and prepare the pipe ends and Union Sockets. Place the Union Collars over the pipe ends. Using plumbing Solvent Cement glue the Union Sockets to the pipe ends.
 - 7.4.8 Ensure that the o-rings are fitted to the Union Sockets and apply a suitable o-ring lubricant if required. Place the Cell Housing between the Unions and tighten the Collars onto the Housing. Do not over tighten the Collars and only tighten them by hand.
 - 7.4.9 Connect the Cell Cable to the Power Module. Place the Cable Connector against the Power Module receptacle. Turn slowly until the bayonet keyway is found, push in and then turn the locking collar clockwise firmly to secure.

8.0 INSTALLATION CHECKLIST

- 8.1.1 Cell Unions installed and glued into pipe work.
- 8.1.2 Union Collars firmly connected into the Cell Housing.
- 8.1.3 The metal Mounting Bracket is securely affixed to a wall or support.
- 8.1.4 The Power Module is mounted and secured in place onto the Mounting Bracket.
- 8.1.5 The Power Module is wired to the correct power source.
- 8.1.6 The Cell Cable is securely connected to the Power Module.
- 8.1.7 Sufficient salt has previously been added and fully dissolved into pool water.
- 8.1.8 You have checked and confirmed that the Power Module switches ON and OFF with the filter pump.
- 8.1.9 You have checked all connections and joints for leaks.

9.0 OPERATION



9.1.1 **Figure 6 - Keypad Controls**

9.2 Start Up Procedure

- 9.2.1 Upon the initial start up of the Titanium Edition unit, the Cell size will need to be selected. When first powered on the display screen will read "SELECT CELL", use the LEFT and RIGHT buttons to change the selection, use the OK button to confirm the selection. The unit will then return to the home screen.
- 9.2.2 If you do not know what size Cell you have, refer to the serial label sticker on the top of the Cell Housing which will state either TE-20G, TE-30G, TE-45G, or TE-60G.
- 9.2.3 Note: Each time the unit is powered on, the display will perform a 1 minute self-test, and then return to the Home Screen.

9.3 Control Panel Buttons

- 9.3.1 **1. On / Off.** For normal operation, the system should be left in the “On” state. In this state the Titanium Edition Unit will produce chlorine according to the desired output %. Simply press the button again to turn the unit off.
- 9.3.2 **2. OK Button.** Holding this button in for 3 seconds will open the User Menu (see section 9.5). This button is also used to select settings, and cycle through menus.
- 9.3.3 **3. Manual Override.** This button allows you a manual override to control the system without having to change the unit's settings. When you have finished with the manual override simply re-press the button to de-activate and return your unit to its normal settings.
- 9.3.4 **4. Salinity Test.** Pressing this button will display the most recent salinity test result (automatically conducted every hour). One of the following readings will be given: "Low Salt" - The salinity level is low and salt needs to be added to the pool water. "Salt OK" - No action is required. "High Salt" - No action is required, the Titanium Edition can run with high salinity, however very high salinity may be unpleasant to swim in and may damage other equipment. To perform a real time salinity test, press the LEFT and RIGHT buttons simultaneously for 3 seconds.
- 9.3.5 **5. Super Chlor.** When you have an abnormally high bather load, a large amount of rain, a cloudy water condition which needs a large amount of purification to be introduced, simply press the SUPER CHLOR button. This electronically “super chlorinates” the water for 24 hours of physical run time. If the unit is turned off by pressing the On/Off button or if the SUPER CHLOR button is pressed again, the unit will return to normal operation.
- 9.3.6 **6. Winter Mode.** When you are not using your pool during the winter months, it is advisable to activate the winter mode. Simply press the WINTER MODE button. The Winter Mode will reduce the output of chlorine to 50% of the set chlorine output. For example: If chlorine output is set to 80%, it will change to 40% when the WINTER MODE button is pressed. To deactivate winter mode, simply press the button again. Note: Reducing the chlorine output during periods when the pool is not in use will help maximize the life of the cell.
- 9.3.7 **7. Output.** Pressing the "+" or "-" buttons will change the chlorine production output in 10% increments. Note: When initially starting up your Titanium Edition chlorine generator it is recommended that the output be set at 100%, decreasing in 10% increments ensuring that the unit is maintaining the appropriate chlorine level in your pool/spa.
- 9.3.8 **8. Left and Right Arrows.** Pressing the LEFT or RIGHT arrow will enable navigation through the menu options.

9.4 Control Panel LED Indicators

- 9.4.1 **Power On.** When illuminated, the Titanium Edition unit has input power activated.
- 9.4.2 **Polarity 1 & 2.** One Polarity LED at a time will be illuminated indicating which operation cycle the unit is on. The system automatically switches polarities in order to inhibit the build up of calcium and other minerals on the cell as part of the self-cleaning feature.
- 9.4.3 **Water Fault.** When illuminated, the flow sensor has detected no water flowing. The display will read “No Flow”. The system will have stopped producing chlorine as a safety measure. Severe low salt conditions will also activate the “Water Fault” warning light.
- 9.4.4 **Low Salt.** The Titanium Edition will automatically let you know if the salinity concentration has fallen below acceptable levels. When illuminated for more than two hours, add more salt as needed. The amount required varies with pool size. Refer to Table 1 to determine additional amount of salt needed.
- 9.4.5 **High Salt.** When illuminated, the salt content is more than sufficient. The Titanium Edition has a built-in regulating system that enables it to continue to produce chlorine with the increased salt content. At this point do not add any further salt and allow the salt content to return to desirable levels.

9.5 Home Screen

- 9.5.1 The Home Screen is the screen displayed during normal operation of the Titanium Edition chlorine generator. The following is displayed on the home screen:
- 9.5.2 **Time:** To change the Time, access the User Menu (see section 9.6.4).
- 9.5.3 **Chlorine Output Setting Percentage:** To change the chlorine output setting, use the "+" and "-" buttons. The setting will be changed in 10% increments.
- 9.5.4 **Chlorine Output Bars:** The Chlorine Output Bars represent the actual amount of chlorine being produced. There are 10 production bars, so if the output is set to 100% there should be 10 bars illuminated, if the output is set to 60% there should be 6 bars. It is normal for the last two bars to fluctuate in illumination. If the Chlorine Output Bars do not match the Chlorine Output Setting, please refer to Troubleshooting (section 11).

9.6 User Menu

- 9.6.1 The User Menu is the main menu used to program the settings. To access this menu hold down the OK button for 3 seconds. Use the OK button to also cycle through the menu.
- 9.6.2 **Language** (factory setting “English”): To change the language simply press the LEFT or RIGHT buttons to scroll through the language options. Press OK to select and move to next menu option.

-
- 9.6.3 **Which Timer** (factory setting "Use External"): Use the LEFT button to change to "Use Internal" if required. The external timer setting is used when the Titanium Edition unit is hardwired to an external time clock, this usually also operates the pump. The Internal time setting is used when the unit is not hardwired to an external time clock, in this scenario the On and Off times will need to be programmed. These are programmed in the same manner as Set Clock below.
- 9.6.4 **Set Clock:** When setting the clock time use the LEFT and RIGHT arrow buttons to select the hour and minutes. Use the "+" and "-" buttons to move the cursor between hour and minutes.
- 9.6.5 **Salt Result:** This is a read out of the most recent salinity test result. One of the following readings will be given: "Low Salt", "Salt OK" or "High Salt".
- 9.6.6 **Cell Select:** This does not normally need to be changed as the Cell size is selected upon initial start up. If the incorrect cell is accidentally selected upon start up, change the selection using the LEFT and RIGHT buttons and then press OK.

9.7 Maintenance Menu

- 9.7.1 Under normal operation, access to the Maintenance Menu is not required. To access the menu for diagnostics, hold the WINTER MODE and SUPER CHLOR buttons simultaneously for 3 seconds.
- 9.7.2 **Self Clean:** The Titanium Edition chlorine generator has an automatic Cell cleaning function that works by reversing the polarity of the Electrolytic Cell. When the polarity is reversed, build up of calcium and other minerals on the Cell plates is removed. The factory setting for the reversing time is 6 hours. There are also 4 hour and 8 hour options that can be selected by using the LEFT and RIGHT buttons. Note: Decreasing the reversing time to 4 hours will reduce the life of the Electrolytic Cell, this should only be done when there are high calcium levels in the pool water and the Cell is calcifying quickly.
- 9.7.3 **Cover Sensor:** This setting is only required when configuring with a pool cover.
- 9.7.4 **Unit Temp:** This is a read out of the real time internal temperature of the Power Module.
- 9.7.5 **Voltage and Current:** This is a display of the real time Voltage and Current outputs to the Cell. This display may be required for troubleshooting problems with the unit.
- 9.7.6 **Peak Temp:** This is a read out of the hottest internal temperature the Power Module has reached. This may be required for troubleshooting problems with the unit.

10.0 MAINTENANCE

10.1 Water Chemistry

- 10.1.1 It is recommended that a pool water sample be taken to a Pool Professional once per month for analysis. Please refer to Water Chemistry (section 5.0) for additional information.

10.2 Electrolytic Cell

- 10.2.1 The cell operates most efficiently when it is clean. As a natural result of the electrolytic process which creates chlorine from salt molecules, calcium is attracted to the titanium plates in the cell. The self-cleaning feature helps to inhibit such build up and scaling. However, the attraction of calcium and other minerals is inevitable and eventually it must be removed. The cell only needs cleaning to ensure that build up does not cause individual plates to come in contact with each other.
- 10.2.2 The clear housing of the cell allows easy visual inspections, and with correct water chemistry, the cell will only need cleaning approximately every 3-6 months. In regions with hard water (high calcium levels), more frequent cleaning may be required.

10.3 Cleaning the Cell

- 10.3.1 Turn power to the filter pump and Power Module off.
- 10.3.2 Remove the cell from its position in the plumbing by loosening the Union Collars on both ends of the Cell. Unplug the Cell Cable from the Power Module if required.
- 10.3.3 With the Cell removed use a high pressure hose nozzle to spray off as much loose scale and debris as possible.
- 10.3.4 Do not use any sharp or metallic objects to remove scale. Scraping or scratching the cell plate's edge or surface will allow chemical attack of the plate, cause premature failure of the cell and will void the warranty.
- 10.3.5 If further cleaning is required the cell needs to be cleaned in a mixture of one (1) part Hydrochloric (Muriatic) Acid into four (4) parts water.
- 10.3.6 **⚠ WARNING:** Chemical Hazard - When mixing acid with water, always add the acid to the water, never add water to the acid. When using the acid ensure to use rubber gloves and appropriate eye protection.
- 10.3.7 Connect the Cell Cleaning Plug to the end of the Cell Housing opposite the cable using the Cell Cleaning Collar (see Figure 7). Place the Cell upright on a stable flat surface with the Plug facing down.



10.3.8 **Figure7** - Cell Cleaning Plug

10.3.9 Fill the Cell with the acid cleaning solution (2-5cm from the top port) and clean until the foaming action stops (typically 5 to 10 minutes). Rinse the cell with fresh water and re-install into the plumbing line.

10.3.10 Note: Do not leave the cleaning solution in the Cell for more than 15 minutes as this may cause damage to the Cell plates. Additionally excessive cleaning will reduce the lifespan of the cell.

10.4 Winterizing the Cell

10.4.1 The Electrolytic Cell will be damaged by freezing water just as your pool plumbing would. In areas which experience severe or extended periods of freezing temperatures, be sure to drain all water from the pump, filter, supply and return lines before any freezing conditions occur. Remove the Cell and store it indoors. The Power Unit is capable of withstanding winter weather and does not need to be removed.

10.5 Replacing the Cell

10.5.1 When the titanium blades inside the Electrolytic Cell have reached the end of their lifespan, replacements are available so that the whole system does not have to be replaced. Replacements are easily switched out. To ensure quality and value, only genuine Compu Pool replacement parts may be used.

10.5.2 To remove the cell for replacement turn power to the filter pump and Power Module off. Disconnect the Cell Cable from the Power Module by turning the locking collar anti-clockwise. Loosen the two Cell Union Collars and remove the cell.

10.5.3 Replace with the new cell in the opposite manner. There are no changes that need to be made to the Power Module control settings when replacing the Cell.

11.0 TROUBLESHOOTING

Problem	Possible Cause	Corrective Action
Power LED and Display Screen not turning on.	Power not connected to unit.	Check that the Power Module is connected to a 208-240 VAC service. Check that the Power Module internal wiring matches the voltage (see section 7.3)
	Circuit Breaker Tripped.	Verify input voltage with a voltmeter. If there is input power, the circuit breaker may have tripped. The Titanium Edition is protected by a 3 amp circuit breaker located at the base of the Power Module. To reset the circuit breaker press the small yellow pin back in. Main power to the unit must be turned off prior to resetting the circuit breaker. Should the circuit breaker continue to trip after this exercise then you should consult Compu Pool for assistance.
	Loose ribbon cable between Power Circuit Board and Display Circuit Board.	Check that the ribbon cable between the Power Circuit Board (back) and the Display Circuit Board (front) is securely connected.
Low or no chlorine residual.	Insufficient chlorine output %.	Increase chlorine production by pressing the "+" button.
	Insufficient running times.	Increase the operating hours of the pool filtration pump and chlorine generator.
	Low stabilizer (cyanuric acid) level in pool water.	Add stabilizer to maintain a level of 30 – 60 ppm.
	Ph too high.	Adjust Ph level to 7.2 – 7.8.
	Temporary loss of chlorine due to heavy bather load, rain, organic matter.	Set the unit to Super Chlor and let run for a 24 hour period. Re-check and if still low take pool water sample to pool professional.
	Salt Content below 2500ppm	Add additional salt to pool to bring salinity within 3000 - 4000ppm (3500 ideal), see Table 1.
	Calcified or clogged cell.	Remove cell from plumbing line and clean (see section 10.3).
	High nitrates or phosphates in pool water.	Contact pool professional.
Metals present in pool water.	Contact pool professional.	

Water Fault LED on.	Insufficient or no water flow through cell.	Check that the pump is operating correctly and turns on and off with the chlorine generator with the timer.
		Ensure that pump strainer baskets are not clogged.
		Check that all valves are opened correctly. Check for any blockages.
		Clean or backwash filter if dirty.
	Pump speed too low (for multi speed pumps)	Increase the pump speed to ensure consistent and sufficient water flow through the Cell.
	No salt in pool water.	Add salt to pool water to reach required level of 3000-4000ppm (3500 ideal), see Table 1.
	Cell Cable not connected to Power Module.	Check that the Cell Cable connector is correctly fitted to the Power Module receptacle and the locking collar is tightened firmly.
Damaged Cell Cable.	Check that the Cell Cable has not been damaged.	
Very cold pool water.	If the pool water is below 45° Fahrenheit, chlorine production will cease and the Water Fault LED will turn on. The pool should be winterized (see section 10.4)	
Low Salt LED on.	Not enough salt added upon start up of pool.	Add salt to pool water to reach required level of 3000-4000ppm (3500 ideal), see Table 1.
	Salinity level decreased over time due to splashing, backwashing, rainfall etc.	Add salt to pool water to reach required level of 3000-4000ppm (3500 ideal), see Table 1.
	Excessive calcium build up on Cell Plates.	Clean Cell as instructed in section 10.3.
	Cold pool water.	Pool water is below 60°F. No action is required, chlorine production is working correctly.
	Dying Cell.	The Electrolytic Cell has come to the end of the "cell life" and is no longer producing chlorine at sufficient levels. Replace the Cell.
High Salt LED on.	Too much salt has been added to the pool.	The salt content is more than sufficient. The Titanium Edition has a built-in regulating system that enables it to continue to produce chlorine with the increased salt content. No action is required, however very high salinity may be unpleasant to swim in and may damage other equipment. Backwash or partially drain pool and add fresh water to reduce the salinity level.
Low Salt LED or High Salt LED on upon startup when known salt level is correct.	Incorrect Cell selected in User Menu	Access the User Menu and select the correct cell, see section 9.6.7.
"NO CELL" reading on display screen.	The Cell Cable is not correctly connected to the Power Module	Ensure the Cell Cable is correctly fitted, refer to section 7.5.9.

Output bars on display screen lower than output % setting.	Last two output bars fluctuating.	It is normal for the last two bars to fluctuate in illumination. Chlorine production is working correctly.
	Pool water salinity is too low.	Add salt to pool water to reach required level of 3000-4000ppm (3500 ideal), see Table 1.
	Excessive calcium build up on Cell Plates.	Clean Cell as instructed in section 10.3.
	Dying Cell.	The Electrolytic Cell has come to the end of the "cell life" and is no longer producing chlorine at sufficient levels. Replace the Cell.
Frequent calcification of the Cell.	Imbalanced water.	The water may contain high pH, total alkalinity and calcium hardness. Balance the water according to section 5.2. Contact a pool professional for assistance.
	Self cleaning reversing time to long.	Access the Maintenance Menu to reduce the cell reversing time (see section 9.6.2). Note: Decreasing the reversing time will reduce the life of the Electrolytic Cell.

12.0 WARRANTY

12.1 Warranty Terms

- 12.1.1 Compu Pool Titanium Edition chlorine generators carry the following 7 year pro rata warranty should fault occur due to faulty manufacture or materials, under normal use and service.
- 12.1.2 For residential use, Compu Pool warrants the original purchaser that the equipment shall be free of manufacturer defects at the time of sale and upon examination, shall provide replacement parts or repair in accordance with the following schedule.
- 12.1.3 **First Year.** Parts supplied from our facility or returned for repair to our facility at no cost. Compu Pool reserves the right to determine whether or not a part will be replaced with a new or refurbished part or repaired.
- 12.1.4 **Second Year.** Parts supplied from our facility or returned for repair to our facility at 20% of the Compu Pool published retail price.
- 12.1.5 **Third Year.** Parts supplied from our facility or returned for repair to our facility at 40% of the Compu Pool published retail price.
- 12.1.6 **Fourth Year.** Parts supplied from our facility or returned for repair to our facility at 60% of the Compu Pool published retail price.
- 12.1.7 **Fifth thru Seventh Year.** Parts supplied from our facility or returned for repair to our facility at 80% of the Compu Pool published retail price.
- 12.1.8 For commercial use in any “regulated pool”, all parts are warranted against defect for a period of one year, without pro-ration.

12.2 Void Warranty

- 12.2.1 The warranty may be void if the following occurs:
- 12.2.2 Damage to the unit beyond Compu Pool's control.
- 12.2.3 Damage due to improper pool chemistry.
- 12.2.4 Damage due to improper installation.
- 12.2.5 Damage due to failure to properly maintain unit.
- 12.2.6 Damage due to improper service.
- 12.2.7 Damage caused by insects or natural elements.

12.3 Warranty Coverage

- 12.3.1 This warranty is applicable to workmanship and materials only and Compu Pool, its agents, employees, and affiliates expressly disclaim responsibility for loss, damage, or injuries to persons or property arising from warranty failure, or installation of equipment.
- 12.3.2 In no event shall Compu Pool be responsible for any consequential, special or incidental damages of any nature whatsoever, including, but not limited to, personal injury, property damage, damage to or loss of equipment, lost profits or revenue, costs of renting replacements, and other additional expenses, even if the seller had been advised of the possibility of such damages.
- 12.3.3 Warranty claims must be initiated in a timely manner

12.4 Customer Warranty Information

- 12.4.1 Please complete the information below at time of installation and retain in the event you need to file a warranty claim

Model Number	
Power Unit Serial Number	
Cell Serial Number	
Purchase Date	
Purchased From	
Installation Date	
Installer	