

TORNADO INDUSTRIES, LLC
3101 WICHITA COURT
FORT WORTH, TX 76140
PHONE 800-VACUUMS
FAX 817-551-0719
WWW.TORNADOVAC.COM



Operations & Maintenance Manual
For Commercial Use Only



BR 28/27 RIDE ON COMPACT SCRUBBER
MODEL NO: 99775



Long Term Buyer Protection Limited Warranty

Tornado Industries, LLC. (Tornado) warrants to the end/user customer that the Tornado product(s) will be free from defects in material and workmanship for the duration(s) described below. This limited warranty DOES NOT cover machines and/or components subject to normal wear and tear, damage that occurs in shipping, failures resulting from modification, accident, unsuitable operating environment, misuse, abuse, neglect, or improper maintenance by you. For full details, contact your Authorized Tornado Distributor, Service Center, or the Tornado Technical Service Department. Tornado sales and service representatives are not authorized to waive or alter the terms of this warranty, or to increase the obligations of Tornado under the warranty.

10 Years*

Plastic water tanks and Rotationally-molded bodies

2 Years*

Parts on all Tornado cleaning equipment

1 Year*

Labor on all Tornado cleaning equipment

1 Year*

Warranty on batteries, one year prorated

All battery warranties are handled directly by the battery manufacturer, on a one year prorated basis

Terms subject to change without notice

1. Except all Windshears™ Blowers, Storm, TV2SS, Side and Downdraft, Insulation Blowers, CV 30, CV 38, CK14/1 PRO, CK 14/2 PRO, SWM 31/9, CK LW13/1, CK LW 13/1 ROAM, CV 38/48 Dual, PV6, PV10, PV6 ROAM, Wall Mount Vacuum and all chargers are warranted for 1 (one) year for both parts and labor.
2. All non-wear item parts purchased after warranty expiration are warranted for 90 days.
3. Warranty starts from the date of sale to the consumer or, at Tornado's discretion, 6 months after the dealer purchased the unit from Tornado, whichever comes first.
4. The EB 30 is warranted for a period of 90 days for both parts and labor.
5. The warranty on engines used on propane powered equipment is limited to motor manufacturer's warranty.
6. Ride-on Scrubbers are warranted for 24 months, parts, 6 months labor or 1,000 hours, whichever occurs first.

Note: Tornado, The Latest Dirt, Floorkeeper, Carpetkeeper, Carpetrinser, Carpetrinser/Dryer, Headmaster, Taskforce, PAC-VAC, T-Lite, Glazer, Windshear, Max-Vac and Trot-Mop are trademarks of Tornado Industries

Website: www.tornadovac.com
Phone 1-800-VACUUMS
Fax 817-551-0719
Address 3101 Wichita Court
Fort Worth, TX 76140



NOTES

Table of Contents		
INTRODUCTORY COMMENT		
TECHNICAL DESCRIPTION		
LEGEND PANEL OF CONTROLS		
LEGEND MACHINE		
GENERAL RULES		
SYMBOLS		
BEFORE USE		
Handling of the packed machine		
Unpacking of the machine		
Access to the battery compartment		
Battery installation		
Check the Setting of the battery Card		
Battery charger		
Battery recharging		
Battery disposal		
Connecting battery connector		
Switching on the machine		
Setting of the battery check card		
Hour meter		
Squeegee assembly		
Squeegee adjustment		
Adjustment height side rubbers		
Brush assembly and disassembly		
FLOOR CLEANING		
Recovery tank		
Detergent solution tank		
STARTING OF THE MACHINE		
Forward and backward movement		
Horn		
Working brake		
Emergency-parking brake		
	Automatic squeegee lift going backwards	16
	5 Working in automatic mode	16
	5 Working in manual mode	16
	6 Flow adjustment of detergent solution	17
	7 Brush pressure adjustment	17
	8 Electric protection	18
	9 Overflow device	18
	10 STOPPING MACHINE AFTER CLEANING	18
	10 DAILY MAINTENANCE	19
	10 Recovery tank emptying and cleaning	19
	10 Emptying and cleaning the collection box	19
	10 Suction filter cleaning	20
	10 Brush cleaning	20
	11 Squeegee cleaning	20
	11 WEEKLY MAINTENANCE	20
	11 Rear squeegee rubber check	20
	11 Check of the side rubbers	20
	11 Squeegee hose cleaning	20
	12 Cleaning of the solution tank and outer filter	21
	12 TWO-MONTH MAINTENANCE	21
	12 Front squeegee rubber check	21
	13 SIX-MONTH MAINTENANCE	21
	13 Cleaning the inner filter solution tank	21
	13 Check the brake	21
	14 TROUBLESHOOTING GUIDE	21
	14 The vacuum motor does not work	21
	14 The brush motor does not work	22
	14 The traction motor does not work	22
	15 The water does not come down onto the brushes or is insufficient	22
	15 The machine does not clean properly	22
	15 The squeegee does not dry properly	22
	Excessive foam production	23
	PROGRAMMED MAINTENANCE	23

Your new Tornado unit is a high quality, precision-made product. All parts used in the manufacturing of this unit have passed rigid quality control standards prior to assembly. Please safeguard the original receipt / invoice. If you experience any problems with your unit during the warranty period, the original receipt / invoice will act as proof of purchase. Contact Tornado for any warranty inquiries.

INTRODUCTORY COMMENT

This floor cleaning machine is used for the industrial and civil cleaning and is able to clean any type of floor. During its forward movement, the combined action of the brushes and the detergent solution removes the dirt which is aspirated through the rear suction assembly, giving a perfectly dry surface. The machine must be used only for such purpose. It gives the best performance if it is used correctly and maintained in perfect efficiency. We therefore ask you to read this instruction booklet carefully whenever difficulties arise in the course of the machine's use. In case of need, we ask you to contact our service department for all advice and servicing as may prove necessary.

TECHNICAL DESCRIPTION	U/M	BR 28/27
Cleaning width	in/mm	28/700
Squeeze width	in/mm	38.5/980
Working capacity	sqft/h/sqm/h	37,673/3500
Brushes diameter	in/mm	2 x 6/150
Brushes RPM	RPM	785
Brush Pressure	lbs./kg	320 max/45 max
Brushes Motor	W/A	2 x 600/2 x 25
Traction Motor	W/A	500/21
Vacuum Motor	W/A	580/24
Type of drive		automatic
Movement speed	mph/km/h	3.1/5
Maximum gradient		10%
Vacuum Motor	inches/mbar	64/160
Solution tank	gal/l	27/100
Recovery tank	gal/l	28/105
Machine length	in/mm	62/1575
Machine height	in/mm	52/1320
Machine width (without squeegee)	in/mm	31/780
Capacity of the batteries	V/Ah ₅	24/240
Weight of the batteries	lbs./kg	441/200
Compartment of the batteries	in/mm	16x21x15 / 415x520x385
Weight of the machine (empty and without batteries)	lbs./kg	578/262
Acoustic pressure level	dB(A)	< 70
Class		III
Protection level	IP	23
Voltage	V	24

LEGEND PANEL OF CONTROLS

1. DISPLAY
2. SIGNAL LAMP MANUAL MODE ON
3. PUSH BUTTON CONNECTION MANUAL MODE
4. SIGNAL LAMP MODE BREAK WASHING ON
5. PUSH BUTTON CONNECTION MODE BREAK WASHING
6. PUSH BUTTON CONNECTION MODE AUTOMATIC
7. SIGNAL LAMP AUTOMATIC MODE ON
8. SIGNAL LAMP SUCTION MOTOR ON
9. SWITCH SUCTION MOTOR
10. ADJUSTMENT KNOB BRUSHES PRESSURE
11. PUSH BUTTON UP/DOWN SQUEEGEE
12. SIGNAL LAMP UP/DOWN SQUEEGEE
13. PUSH BUTTON VISUALIZATION HOUR METER (DISPLAY)
14. PUSH BUTTON VISUALIZATION BRUSHES PRESSURE SET (DISPLAY)
15. SIGNAL LAMP PARKING BRAKE ON
16. SIGNAL LAMP UP/DOWN BRUSHES
17. PUSH BUTTON UP/DOWN BRUSHES
18. SIGNAL LAMP STARTING BRUSHES ROTATION
19. PUSH BUTTON WATER OPENING (SOLENOID VALVE) or PUSH BUTTON ADJUSTMENT DETERGENT DOSAGE 3SD system (OPTIONAL)
20. SIGNAL LAMP WATER OPEN (SOLENOID VALVE)
21. PUSH BUTTON FOR SPEED SELECTION
22. SIGNAL LAMP SELECTION MAXIMUM SPEED
23. SIGNAL LAMP SELECTION SLOW SPEED
24. KEY SWITCH MACHINE ON
25. SWITCH FOR FRONT LIGHT (OPTIONAL)
26. PUSH BUTTON HORN
27. KNOB FOR SOLUTION VALVE
28. SELECTOR DIRECTION OF DRIVE

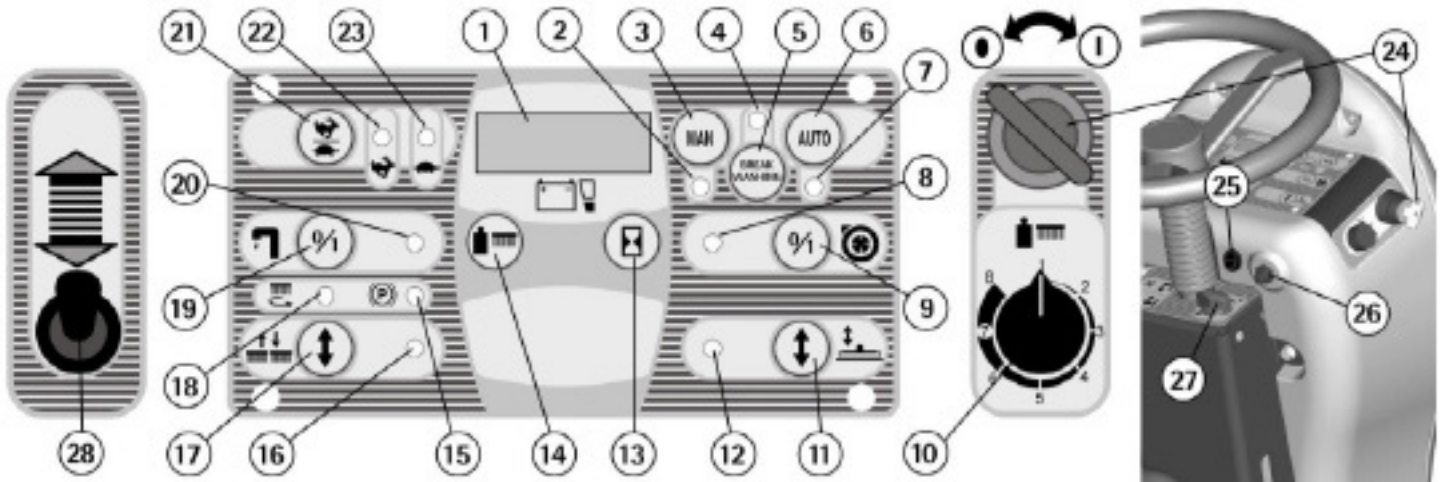

LEGEND MACHINE

1. RECOVERY TANK
2. SOLUTION TANK
3. SEAT
4. STEERING WHEEL
5. SCREW CAP FOR SOLUTION TANK
6. SUCTION HOSE
7. SUCTION COVER
8. BLOCKING LEVERS SUCTION COVER
9. SQUEEGEE HOSE
10. EXHAUST HOSE PLUG RECOVERY TANK
11. EXHAUST HOSE RECOVERY TANK
12. SQUEEGEE ASSEMBLY
13. PANEL CONTROLS
14. LEVER BLOCK/RELEASE PARKING BRAKE
15. COVER ELECTRICAL LAYOUT
16. BRAKE PEDAL
17. BUMPER
18. ACCELERATOR PEDAL
19. OUTER FILTER DETERGENT SOLUTION
20. STEERING WHEEL
21. BOTTOM PLATE
22. BRUSHES BASE GROUP
23. TRACTION WHEELS

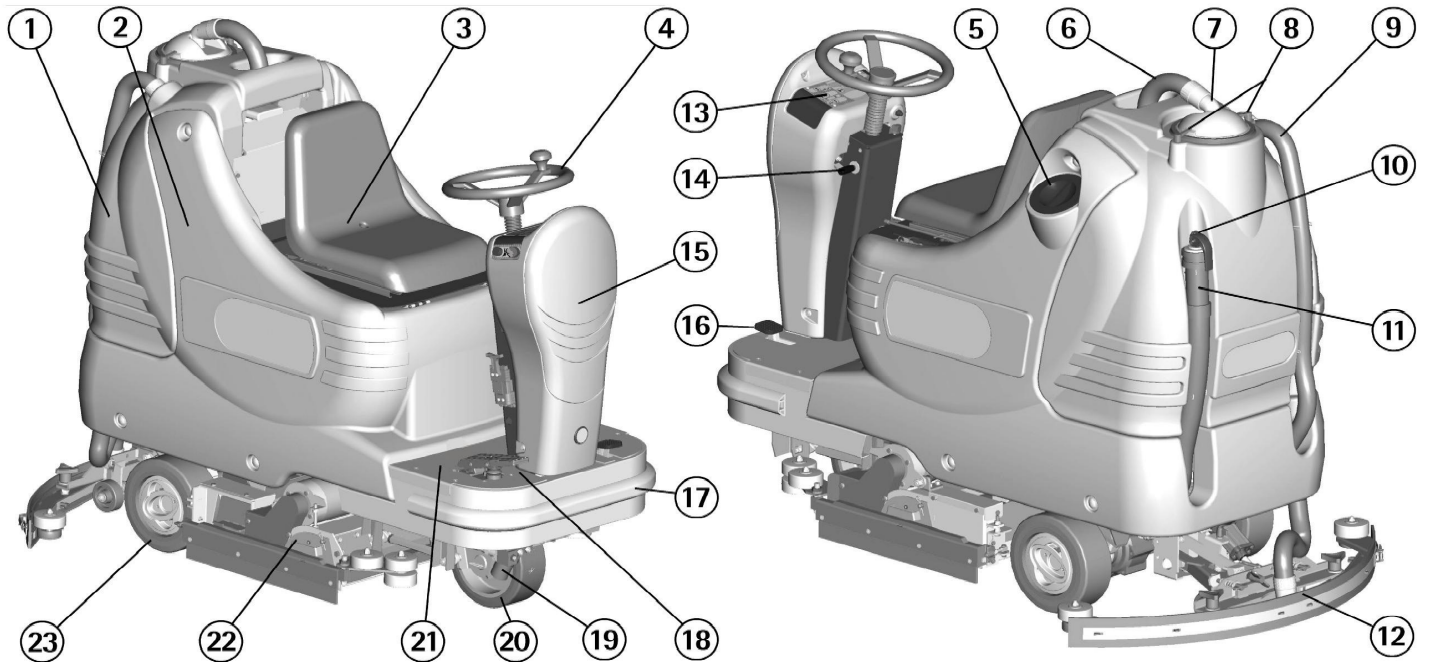

IMPORTANT SAFETY INSTRUCTIONS

READ AND UNDERSTAND ALL INSTRUCTIONS BEFORE USING THIS UNIT

Read and understand this owner's manual and all labels on the unit before operating. Safety is a combination of common sense, staying alert and knowing how your unit works. Use this unit only as described in this manual. Use only manufacturer's recommended attachments. To reduce the risk of personal injury or damage to your unit use only Tornado recommended accessories.

GENERAL RULES OF SECURITY

The rules below have to be followed carefully in order to avoid damages to the operator and to the machine.

- Read the labels carefully on the machine. Do not cover them for any reason and replace them immediately if damaged.
 - The machine must be used exclusively by authorized staff that has been instructed for its use.
 - During the working of the machine, pay attention to other people and especially to children.
 - In case of danger act immediately upon the emergency brake.
 - Leaving the machine in parking position, take off the key and act upon the parking brake.
 - Do not mix different detergents, avoiding harmful odors.
 - Signal the areas of moist floors with suitable signs.
- Do not place any liquid containers onto the machine.

- Storage temperature: between -13°F and 131°F (25°C and +55°C)..
- Perfect operating temperature: between 32°F and 104°F (0°C and 40°C).
- The humidity should be between 30 and 95%.
- Do not use the machine in explosive atmosphere.
- Do not use the machine as a means of transport.
- Do not use acidic solutions in such concentrations that could damage the machine and/or the persons.
- Do not use the machine on surfaces covered with inflammable liquids or dusts (for example hydrocarbons, ashes or soot).
- In case of fire, use a powder fire-extinguisher.

Do not use water.

- Do not strike shelvings or scaffoldings, where there is danger of falling objects.
- Adapt the working speed to the conditions.
- Do not use the machine on areas having a higher gradient than the one stated on the number plate.
- The machine has to carry out simultaneously the operations of washing and drying. Different operations must be carried out in restricted areas prohibited to non-authorized personnel. Signal the areas of moist floors with suitable signs.
- If the machine does not work properly, check by conducting simple maintenance procedures. Otherwise, ask for technical advice to an authorized assistance center.

- Where parts are required, ask for ORIGINAL spare parts to the distributor and/or to an authorized dealer.
- Use only ORIGINAL brushes indicated in the paragraph "RECOMMENDED BRUSHES".
- For any cleaning and/or maintenance operation take off the power supply from the machine.
- Do not take off the protections which require the use of tools to be removed.
- Do not wash the machine with direct water jets or with high water pressure nor with corrosive material.
- Every 200 working hours have a machine check through an authorized service department.
- In order to avoid scales on the solution tank filter, do not fill the detergent solution many hours before the machines' use.
- Before using the machine, check that all panels and coverings are in their position as indicated in this use and maintenance catalogue.
- Be sure the recovery tank is empty before lifting it.
- Restore all electrical connections after any maintenance operation.
- Provide for the scrapping of the material of normal wear following strictly the respective rules.
- When your machine has to stop activity, provide for the appropriate waste disposal of its materials, especially oils, batteries and electronic components, and considering that the machine itself has been, where possible, constructed using recyclable materials.

Symbol denoting the solution valve.
 Indicates the solution valve lever. Indicates the signal lamp of the solenoid valve functioning.

Symbol denoting the brush.
 Indicates the switch of the brush motor.

Symbol denoting the suction motor.
 Indicates the switch of the suction motor.

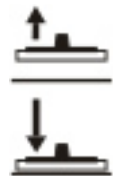
Symbol denoting up – down of the squeegee.
 Indicates the squeegee lever.

Symbol denoting the selection switch of the driving speed.



Symbol that indicates the lever for the brush base lifting or the push button up/down brush base.



Symbol denoting the charge level of the batteries.



Symbol denoting the hour meter.



Indication of the maximum temperature of the solution detergent.
 It is placed near the charging hole of the solution tank.

Symbol denoting the brake.
 Indicates the signal lamp of the brake on.

Symbol denoting the brake.
 Indicates the lever of the emergency and parking brake.

Symbol denoting the crossed bin. Indicates that at the end of its activity, the machine has to be disposed conforming to the laws in force.



Symbol denoting the open book.
 Indicates that the operator has to read the manual before the use of the machine.

Warning symbol.
 Read carefully the sections marked with this symbol, for the security of both the operator and the machine.

Symbol denoting the functioning of the solution valve adjusting the flow of the detergent solution.

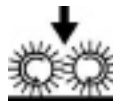

Symbol denoting the selection witch of the operation mode manual/automatic.

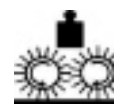

Symbol denoting the push button and the signal lamp up/down brushes.

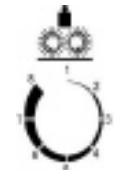

Symbol denoting the signal lamp of the starting of the brushes rotation.

Symbol denoting the push button to visualize on the display the brush pressure set.

Symbol denoting the functioning of the adjustment knob of the brush pressure.

Symbol denoting the push button and the signal lamp up/down of the squeegee.

Symbol denoting the drive selector forwards/backwards.

Symbol denoting the lever position for the connection of the parking brake.

BEFORE USE

HANDLING OF THE PACKED MACHINE

The machine is supplied with suitable packing for fork lift truck handling.

The total weight is 644 lbs./292 kg.

Packing dimensions:

Base: 71 in 178 cm x 37 in 93 cm.

Height: 54 in 138 cm.



ATTENTION:

Do not place more than 2 packings on top of each other.

UNPACKING OF THE MACHINE

1. Remove the external packing.
2. Unscrew the brackets (1+2) that secure the machine to the pallet.

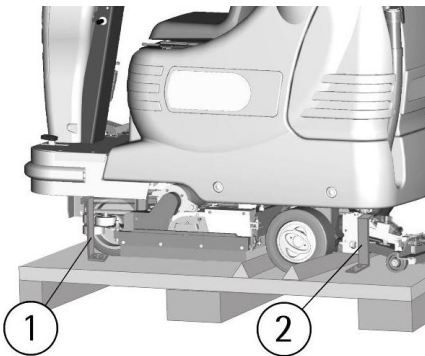

3. Move the machine backwards, as indicated in the figure, avoiding heavy contacts to mechanical parts.

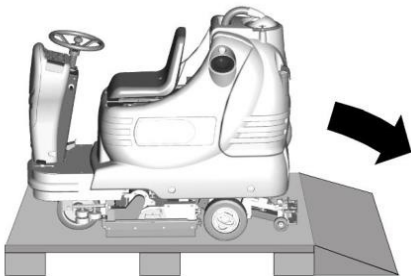

4. Keep the pallet and the brackets for future transport.

ACCESS TO THE BATTERY COMPARTMENT

1. Bring the machine on a level surface.
 2. Rotate the seat platform forward and hook the bar.
- Having finished any intervention, to close the battery compartment, reposition the seat platform.

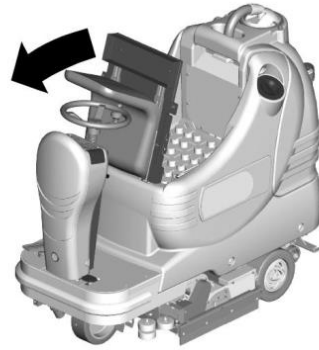

To install into the compartment a battery box, it is necessary to:

1. Rotate the seat platform forward and hook the bar (2) into position A.

2. Remove the holder (1) by unscrewing the two wing nuts under the platform.
3. Pull outwards the releasing lever (3) of the seatmaking slide the seat body (4) up to the highest position.
4. Rotate further the platform in order to hook the bar (2) into position B.

In this way it will be possible to handle the batteries with suitable lifting equipment.

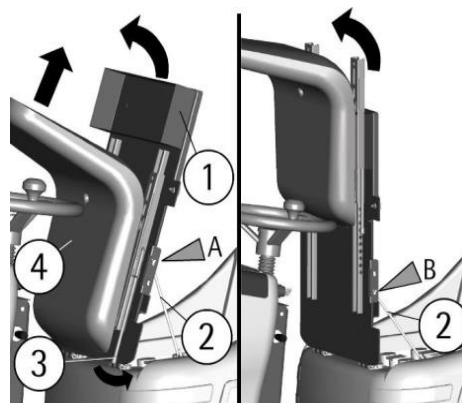

BATTERY INSTALLATION AND SETTING OF THE BATTERY TYPE

The machine is equipped either with a battery in serial connection or elements of DIN-type assembled together and connected in series for a total of 36 Volts, placed in its appropriate compartment under the seat platform. It must be handled using suitable lifting equipment (due to weight, considering the type of battery chosen, and coupling system).

The battery must be in accordance with CEI 21-5 Norms.



ATTENTION:

The machine and its battery check card foresee the use of traditional lead batteries.

CHECK THE SETTING OF THE CHECK CARD (see under paragraph "BATTERY CHARGE LEVEL INDICATOR").

In case of GEL battery installation, it is necessary to set the battery check card. Please contact an authorized technical assistant.



ATTENTION:

Strictly follow manufacturer/distributor indications for the maintenance and recharge of the battery. All installation and maintenance operations must be executed by specialized staff using suitable protection accessories.

For battery installation it is necessary to reach the battery compartment as indicated under the paragraph "ACCESS TO THE BATTERY COMPARTMENT".

1. Place the battery in its compartment.
 2. Connect the terminals, respecting the polarities, avoiding contact with other parts that could create a short circuit.
- BATTERY CHARGER**

Make sure that the battery charger is suitable for the installed battery both for their capacities and for type (WET and equivalent). In the plastic bag containing the use and maintenance you will find the coupling connector for the charger. It must be assembled onto the cables of your charger, following the instructions given by the manufacturer.



ATTENTION:

This operation must be carried out by qualified staff. A wrong or faulty cable connection can cause serious damage.

BATTERY RECHARGING

1. Plug the connector (3) of the battery charger into the battery connector (1) fixed on the steering column.
2. Proceed to recharging.

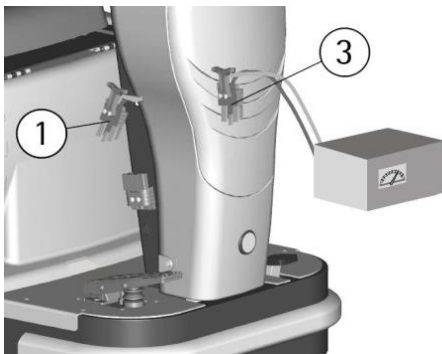

ATTENTION:

Never charge a WET battery with a non-suitable recharger. Strictly follow the instructions supplied by the battery and recharger manufacturer. In order not to cause permanent damage to the battery, it is necessary to avoid their complete discharge, providing for the recharging within a few minutes after that the battery discharge signal starts blinking.

NOTE: Never leave the battery completely discharged even if the machine is not used. In case of traditional battery, please check the electrolyte level every 20 recharging cycles and eventually top them up with distilled water. Never leave the battery discharged for more than two weeks.



ATTENTION:

For the recharging of the battery it is necessary to follow strictly all the indications given by the manufacturer/distributor. All the installation and maintenance operations must be carried out by qualified staff. Danger: gas exhalations and emission of corrosive liquids. Do not approach with open flame.

BATTERY DISPOSAL

Hand over exhausted battery, classified as dangerous waste, to an authorized institution according to the current laws.

CONNECTING BATTERY CONNECTOR AND SWITCHING ON THE MACHINE

Once the battery recharging has been completed:

1. Disconnect the connector of the battery recharger from the battery connector (1).
2. Connect instead the machine connector (2).

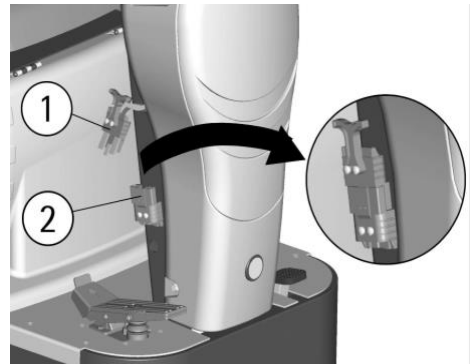

SWITCHING ON THE MACHINE

To start any function of the machine, rotate the key switch clock-wise. Rotating it counter-clockwise will turn off all functions (see "LEGEND PANEL OF CONTROLS").

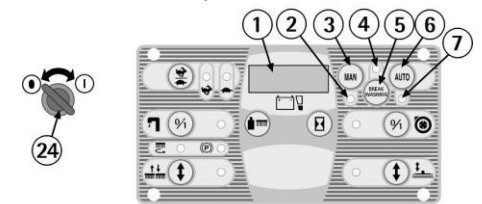

WHEN THE MACHINE IS SWITCHED ON, ON THE DISPLAY (1) APPEAR IN ORDER THE FOLLOWING INFORMATION:

1. model of the machine (for example AdS).

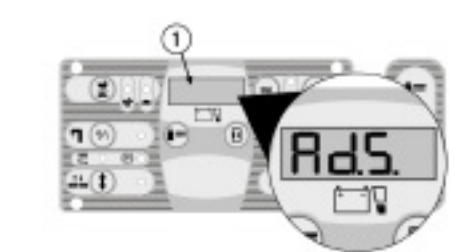

2. the indication of the setting of the battery check card which can be:
GE 36 (check card set for GEL batteries).
or

Pb 36 (check card set for lead batteries).

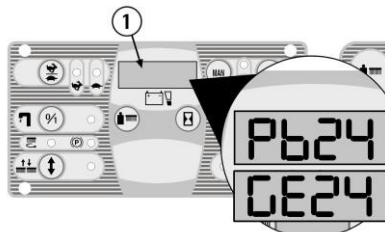

3. the version of software of the check card installed on the machine (for example 4-6).

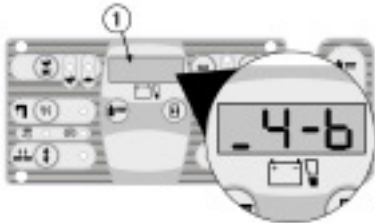

4. The batteries charge level indicator is digital and remains fixed on the display. The battery charge level starts from -100-, which indicates the 100% of the total charge and decreases by 10 to 10. When the charge level reaches the value -20-, the display starts blinking, so you are about the end of working.

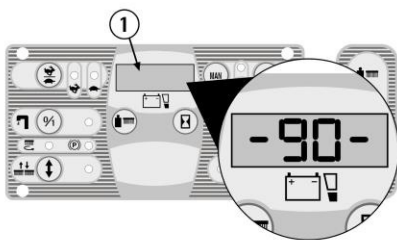

ATTENTION:

After a few seconds of the indication -10- blinking, automatically the brushes function is stopped, while the suction continues to work. On visualization of the four blinking lines, also the suction will stop automatically. The traction instead will function, so to transfer the machine to the suitable place for tank draining and battery recharging

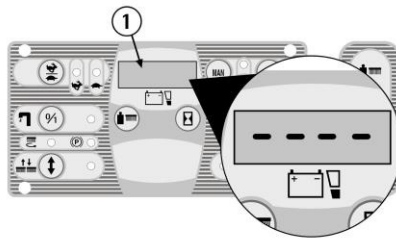

SETTING OF THE BATTERY CHECK CARD

The setting of the battery check card can be:

GE 36 (check card set for GEL batteries).

or

Pb 36 (check card set for lead batteries).

The machine, if not specified otherwise, is supplied with the battery check card set for lead batteries. To modify this setting, it is necessary to:

1. Switch off and on the machine.
2. Immediately after having switched on, when on the display (1) the writing Pb36 appears, press simultaneously the push buttons (3) and (6) up to the blinking of the writing.
3. When the writing begins to blink, take off the fingers from the push buttons and press once the push button (6).
4. The writing GE36 appears blinking.
5. When the writing stops to blink, the setting is modified. For the passage of the setting from gel batteries into lead batteries, repeat the procedure pressing button (3) instead of button (6).



ATTENTION:

As the machine is 36V version, do not set the batteries at 24V.

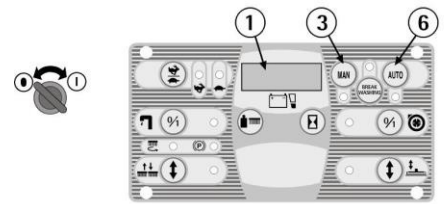

HOUR METER

The machine is equipped with an hour meter located on the same display (1) of the battery charge level indicator. Hold the button (9) to show the working hours on the screen. Hold the button a few more seconds for the working minutes to appear.

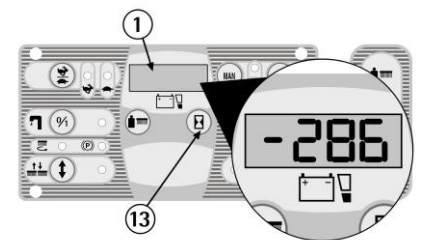

SQUEEGEE ASSEMBLY

1. Keep the squeegee support (1) slightly lifted from the floor.
2. Insert the two stud bolts (3) placed on the upper part of the squeegee (2) inside the slots on the support.
3. Block the squeegee by rotating the lever (4) clockwise.
4. Insert the squeegee hose (5) into its coupling, respecting its position as indicated in the figure.

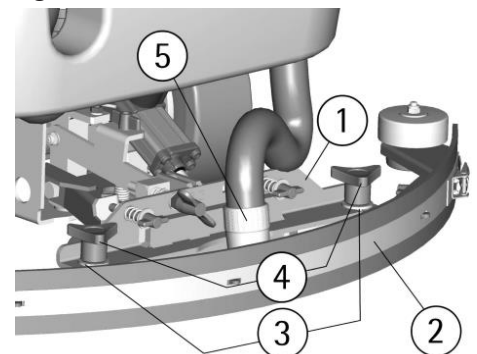

SQUEEGEE ADJUSTMENT

In order to have better drying result with the squeegee, the rear rubber must have its lower bending uniformly adjusted in all its length. For the adjustment, the vacuum motor has to be switched on and the brushes have to function together with the detergent solution.

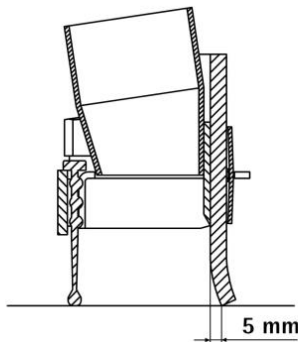

The lower part of the rubber is too much bent

Take off the pressure rotating the wing nut (6) counterclockwise.

The lower part of the rubber is not much bent

Increase the pressure rotating the wing nut (6) clockwise. Check that the wheels which adjust the height do not rest on the floor, in this case adjust them as indicated in paragraph "Height adjustment".

The bending is not uniform Adjust the squeegee inclination rotating counterclockwise the wing nut (7) to increase the bending in the central part, or clockwise to increase the bending on the extremities.

Height adjustment

Once that the pressure and inclination of the squeegee have been adjusted, it is necessary to fix this optimum condition making touch slightly the wheels onto the floor.

Rotate counterclockwise the registers (8) to lower the wheels or clockwise to raise them. Both wheels must be adjusted in the same measure.

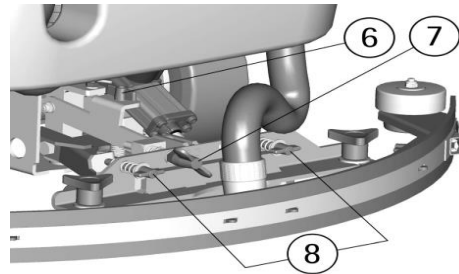

ATTENTION:

Every type of floor requires a specific adjustment. For example, concrete floors (where friction results to be high) need little pressure, while smooth floors (ceramics) need higher pressure. If the cleaning operations are always made on the same type of floor, adjust according to rubber wear.

ADJUSTMENT HEIGHT SIDE RUBBERS

Loosen the upper blocking nuts. Use the adjusting screws (1) and (2) to adjust the height of the side rubbers: unscrewing lowers the rubber while screwing down lifts the rubber. Tighten the blocking nuts after adjustments are made.

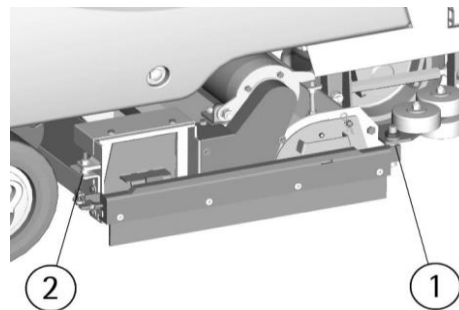

BRUSH ASSEMBLY AND DISASSEMBLY

To assemble and disassemble the brushes on both sides of the machine:

1. Position the selector (8) for the adjustment of the brush pressure on position P1.
2. Activate the machine (see "STARTING OF THE MACHINE") positioning the selector (3) to the right to choose the manual mode (MAN).
3. Activate the selector (13) of up/down of the brush base to lower the brushes. Once it is lowered, the brushes begin to turn.
4. Turn the key counter clockwise to turn off the machine



ATTENTION:

Carrying out brush assembly operations with the electric supply on may cause damage to hands.

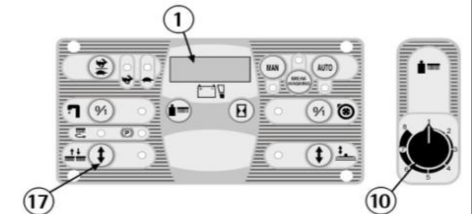

ATTENTION:

This operation must be carried out using gloves to protect from contact with dangerous solutions.

5. Unblock the bar of the side rubber after having released the knob (1).

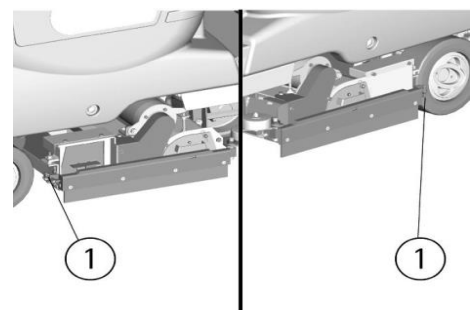

6. Open the bar of the side rubber (2) as shown in the figure.

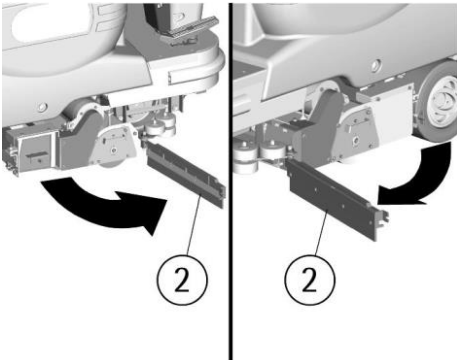

7. Extract the support plate (3) of the brushes by pulling it outwards while holding its handle.
8. Extract the brush (4).

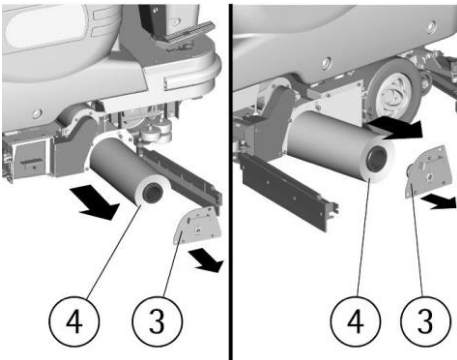

9. During the reassembly of the brush (4), insert it into the brush base from the part where the seat is deeper (about 40mm). The opposite part with a depth of about 13,5mm has to look towards the support plate.

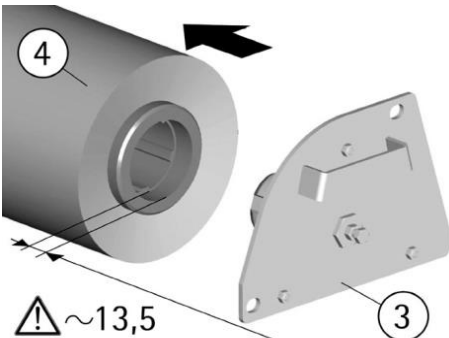

10. Place the support plate (3) into its position, then put back the bar of the side rubber (2) blocking it with the knob (1).



ATTENTION:

Use only the brushes supplied with the machine or the ones indicated in the paragraph “RECOMMENDED BRUSHES”. The use of other brushes may produce poor cleaning results.

FLOOR CLEANING RECOVERY TANK

Rotate the levers (2). Check that the cover of the suction filter (1) is correctly secured, and that the vacuum motor hose (3) is correctly connected to it. Verify also that the squeegee hose couplings (4/5) are correctly inserted into their seats and that the exhaust hose plug (6) is placed in the lower rear part of the machine.

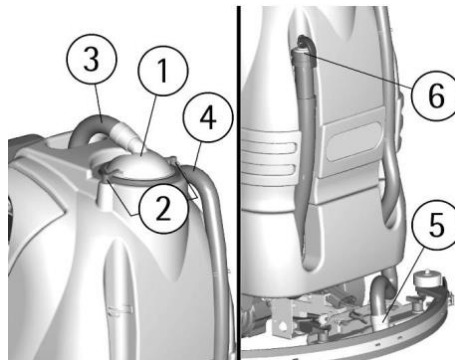

DETERGENT SOLUTION TANK

The capacity of the detergent solution tank is indicated in the technical data. Open the screw plug placed in the left part of the machine and fill the detergent solution tank with clean water at a maximum temperature of 122°F (50°C). Add the liquid detergent in the percentage and conditions shown by the manufacturer. To avoid excessive foam presence, use the minimum percentage of detergent. Screw down the plug to close the tank.

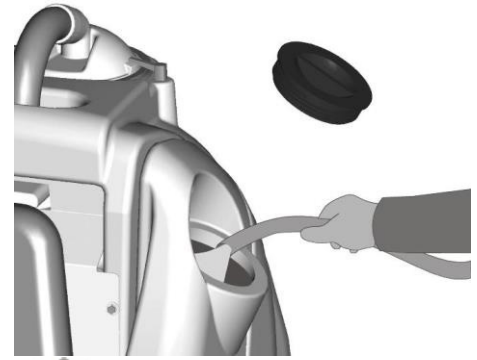

ATTENTION:

Always use low foam detergent. To avoid foam presence, pour into the recovery tank a minimum quantity of anti-foam product. Never use pure acid.

STARTING OF THE MACHINE

A safety device avoids the machine’s movement if the operator is not seated correctly on the guiding place.

To switch on the machine:

1. Sit on the seat.
2. Turn the key switch (24) clockwise to switch on the machine. Automatically, the machine gets ready in manual (MAN) mode and in forward movement with the quick speed (signal lamp 22).
3. Check the charge level of the batteries on the display (1).
4. Pressing the push button (5) the functioning of BREAK WASHING is chosen and the transfer operations of the machine are carried out (see under paragraph “FORWARD AND BACKWARD MOVEMENT”). When the signal lamp (4) is on, then the machine is in BREAK WASHING mode.
5. Pressing the push button (6) the automatic (AUTO) functioning is chosen, while pressing the push button (3), the functioning of the machine becomes manual (MAN).

A. When the signal lamp (7) is on, the machine is functioning in automatic (AUTO) model and the machine activates and deactivates all the working functions in an automatic mode (see under paragraph "WORKING IN AUTOMATIC MODE").

B. When the signal lamp (2) is on, the machine is functioning in manual (MAN) mode and it is possible to choose if:

I. to carry out the only transfer of the machine without activating or deactivating the working functions.

II. to activate separately only the controls relative to the washing function with the brushes (see under paragraph "WORKING IN MANUAL MODE").

III. to activate separately only the controls relative to the drying function with the squeegee (see under paragraph "WORKING IN MANUAL MODE").



ATTENTION:

In manual mode every function of the machine has to be activated or deactivated manually.

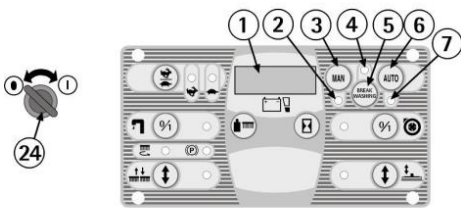

FORWARD AND BACKWARD MOVEMENT

It is recommended to carry out always the mere transfer of the machine in mode (BREAK WASHING).

To proceed to activate the movement of the machine:

1. Sit on the guiding place.
2. Turn the key switch (24) clockwise to switch on the machine.
3. Check the charge level of the batteries on the display (1).
4. Pressing the push button (5) the functioning of BREAK WASHING is chosen to carry out the mere transfer of the machine. In fact, in this mode the washing functions of the machine are not working and only the traction system functions.

When the signal lamp (4) is on, then the machine is in BREAK WASHING mode.

5. Check through the signal lamp (15) that the parking brake is not inserted and eventually release it (see under paragraph EMERGENCY-PARKING BRAKE).

6. Positioning the selector (28) forward, the forward drive is chosen, while positioning it back, the rear drive is chosen.
7. Press the accelerator pedal placed on the right part of the platform to start the machine.

8. Adjust the movement speed in forward pressing every time the push button (21) to choose the slow one (at the maximum 2.2mph/3,6km/h is reached) or the fast one (at the maximum 3.8mph/6.1km/h is reached). The signal lamp (22) indicates that the fast drive is selected, while signal lamp (23) indicates that the slow drive is selected.

9. In backward movement, when the machine is moving, an intermittent warning device is activated.

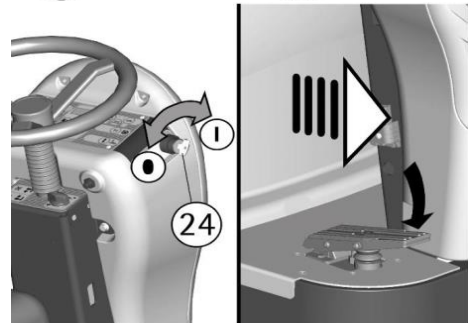
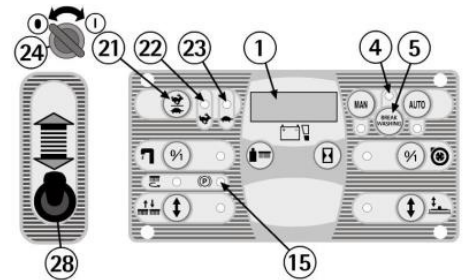

HORN

The machine is equipped with a horn which is activated pressing the push button (1).

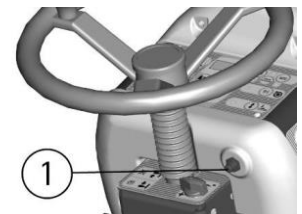

WORKING BRAKE

To stop the machine during normal working situations, release the accelerator pedal. The machine has an electronic brake system. To restart, press the accelerator pedal.

EMERGENCY-PARKING BRAKE

In case of an emergency press the pedal of the emergency and parking brake (1) placed on the left side.

To insert the parking brake press the brake pedal (1) and simultaneously move downwards the lever (2) placed on the left side of the steering column.

On the instrument board the signal lamp (15) comes on which signals that the parking brake is inserted.

To release the parking brake it is sufficient to press the brake pedal (1) and automatically it is released.

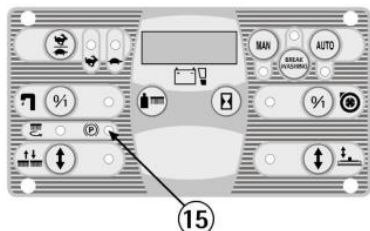
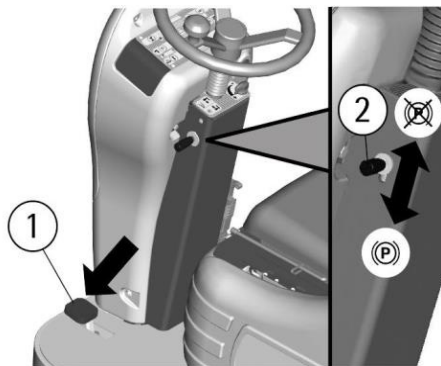

AUTOMATIC SQUEEGEE LIFTING GOING BACKWARDS

Selecting the backwards movement the squeegee is brought automatically to the upper position. It will then lower again in the following forward movement.

This happens both in automatic and manual mode in order to protect the integrity of the squeegee.

WORKING IN AUTOMATIC MODE

The automatic operation is useful to simplify the operator's work.

1. Activate the machine (see under paragraph "STARTING OF THE MACHINE").
2. Pressing the push button (6) the automatic (AUTO) functioning is chosen.

When the signal lamp (7) is on, then the machine is functioning in automatic (AUTO) mode.

3. Check that the knob of the solution valve (27) is in the position of optimum flow, depending on the type of floor and the type of dirt (see under the paragraph "FLOW ADJUSTMENT OF THE DETERGENT SOLUTION").

4. Position the selector (28) forward to choose the forward drive.

5. Adjust the movement speed in forward with the push button (21) (see under paragraph "FORWARD AND BACKWARD MOVEMENT").

6. Pressing the accelerator pedal, the machine begins to proceed and in automatic mode all the working functions are activated. In fact, automatically both the brushes base and the squeegee go down, the brushes begin to turn, the solenoid valve opens to permit the detergent solution to flow down onto the brushes and the suction system is activated to recover the dirty water from the floor.

Positioning backwards the selector (28) to choose the rear drive and pressing the accelerator pedal the rear drive starts, the squeegee lifts automatically and will then return to lower itself during the next forward movement.

If the accelerator pedal is released for more than 3 seconds, automatically all the functions are being switched off and both the brushes base and the squeegee are being lifted. Pressing again the pedal, the machine starts to move again and in automatic mode all the working functions are reactivated.

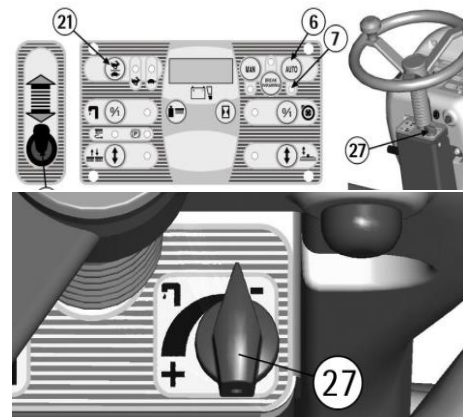

WORKING IN MANUAL MODE

The manual mode is useful when the operator wants to carry out separately the washing and drying of the floor.



ATTENTION:

Washing and drying functions that are not carried out simultaneously represent an improper use of the machine (see under paragraph "GENERAL RULES OF SECURITY"). If they are carried out separately, forbid the working areas to the passage of nonauthorized personnel. Signal the areas of moist floors with suitable signs.

1. Activate the machine (see under paragraph "STARTING OF THE MACHINE").

2. Pressing the push button (3) the functioning of manual (MAN) mode is chosen. When the signal lamp (2) is on, then the machine is functioning in manual (MAN) mode.

TO CARRY OUT THE WASHING WITH ONLY THE BRUSHES:

1. Check that the knob of the solution valve (27) is in the position of optimum flow, depending on the type of floor and the type of dirt (see under the paragraph "FLOW ADJUSTMENT OF THE DETERGENT SOLUTION").

2. Press the push button (17) of up/down of the brushes base to lower the brushes. Once that it is lowered, the brushes begin to turn. The blinking signal lamp (16) indicates that the brushes base is lowering or raising (the signal remains on when the brushes base is in working position), while the signal lamp (18) signals that the brushes are turning.

3. Press the switch (19) to open the solenoid valve and permit the detergent solution to lower onto the brushes. The signal lamp (20) will come on, to indicate that the solenoid valve is open.

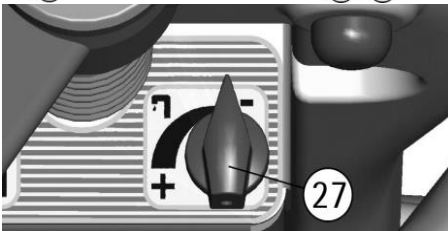
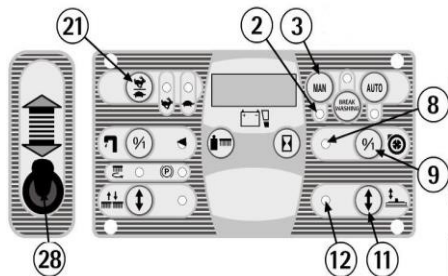

TO CARRY OUT THE FUNCTION OF ONLY DRYING:

1. Press the push button (11) of up/down squeegee to lower the squeegee. The signal lamp (12) indicates that the squeegee is lowering or lifting (the signal remains on when the squeegee is in working position).

2. Press the switch (9) of the suction motor to start the suction system. The signal lamp (8) indicates that the machine is drying.

Position the selector (28) forward to choose the forward drive.

Adjust the movement speed in forward with the push button (21) (see under paragraph "FORWARD AND BACKWARD MOVEMENT").

Pressing the accelerator pedal, the machine begins to proceed forward and to work according to the set functions.



ATTENTION:

In manual mode every function of the machine has to be activated or deactivated manually.

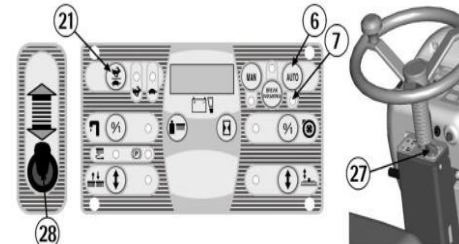

WORKING ADJUSTMENTS

Both in automatic as in manual mode, during the first metres check:

1. that the squeegee adjustment guarantees a perfect drying result (see under paragraph "ADJUSTMENT OF THE SQUEEGEE").
2. that the adjustment of the detergent solution flow is sufficient to wet the floor uniformly avoiding the leakage of detergent from the splash guards (see under paragraph "FLOW ADJUSTMENT OF THE DETERGENT SOLUTION").
3. that the brushes pressure permits an efficient washing action in function of the dirt and the speed (see under paragraph "ADJUSTMENT OF THE BRUSHES PRESSURE").

FLOW ADJUSTMENT OF THE DETERGENT SOLUTION

To adjust the detergent solution quantity that flows down onto the brushes it is necessary to act upon the solution valve knob (27) placed on the right of the steering column, rotating counterclockwise to increase it and clockwise to reduce it up to close the flow.

It is convenient to adjust the flow during working operation and at each adjustment of the brushes pressure.

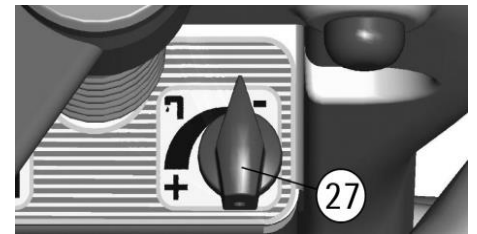

ADJUSTMENT OF THE BRUSHES PRESSURE

Both in automatic and in manual mode it is possible through the selector (10) to adjust the brushes pressure on the floor in eight established levels. During the operation, we can visualize on the display (1) the value in percentage of the electric absorption of the brushes motor by pressing the button (14). The adjustment occurs in this way both in automatic and in manual mode.



ATTENTION:

The presence on the display (1) of a blinking warning from P2 to P8 indicates that the pressure level set determines an overload of the brushes motor. It is therefore necessary to reduce the pressure up to the level where the blinking warning stops.

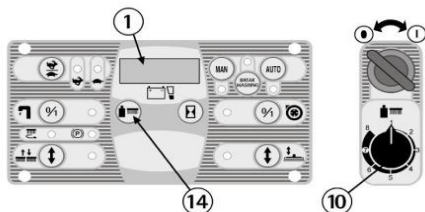

ELECTRIC PROTECTION

The machine is equipped with an electronic system of protection for all components that carry out functions of power or control. This device blocks the defective component and indicates on the display (1) the corresponding alarm from "A1", "A2" and on.



ATTENTION:

To restore the functioning of the component, turn off and on again the machine acting upon the key switch. If the problem persists, please contact the authorized technical assistance

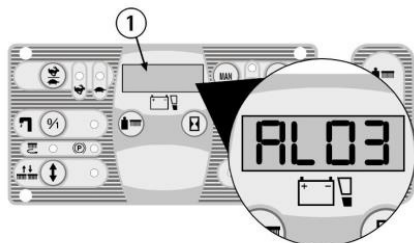

OVERFLOW DEVICE

In order to avoid serious damages to the suction motor, the machine is equipped with a mechanical float that intervenes when the recovery tank is full, closing the suction. For the machines equipped with electric float switch (optional), the switching off of the suction motor and its signal lamp (12) happens automatically.

When this happens, it is necessary to empty the recovery tank (see under paragraph "RECOVERY TANK EMPTYING AND CLEANING").



STOP OF THE MACHINE AFTER CLEANING OPERATION

IN AUTOMATIC OR MANUAL WORKING MODE:

1. At the end of the washing cycle, pressing the push button (5), the functioning of BREAK WASHING is chosen. When the signal lamp (4) is on, then the machine is in the functioning mode BREAK WASHING. In this way automatically the solenoid valve shuts down, the brushes are lifted of a few millimeters continuing to turn for about 10 seconds (drying phase of the brushes) and the collection box drains the excess water to the floor; then, the washing group lifts completely while the squeegee continues to remain in working position with the suction motor on, after 5 seconds the squeegee lifts and when it reaches the highest position, the suction motor stops, with a delay of another 5 seconds.

NOTE: all these phases are carried out with the machine operating, so that the squeegee can dry the interested cleaning area from the "drying phase of the brushes" and furthermore can dry the suction hose of its dirty water.

At any time it is possible to interrupt the procedure BREAK WASHING by stopping the drive.

2. During the phase of BREAK WASHING, when the accelerator pedal is released for more than 3 seconds, the squeegee raises itself and the suction switches off automatically.

3. After three seconds, the accelerator can be pressed again, if a machine's transfer has to be made (you can anyway make the transfer even if the pedal is not lifted once that 20 seconds have passed).

4. Turn the switch key counterclockwise to switch off the machine.

5. Insert the parking brake (see under paragraph "EMERGENCY-PARKING BRAKE").



ATTENTION:

The mode (BREAK WASHING) is specific for the transfer at the end of the cleaning operation

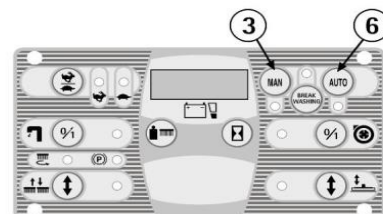

A. by pressing the push button (6) the automatic (AUTO) functioning is chosen to start working in automatic mode.

B. by pressing the push button (3) the manual (MAN) functioning is chosen to start working in manual mode and all functions have to be re-established manually.

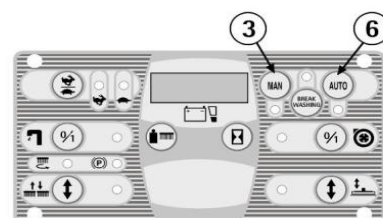

DAILY MAINTENANCE



ATTENTION:

All the following maintenance and cleaning operations that refer to the following components that are in contact with liquids and therefore:

- Solution and recovery tanks
- collection box
- Solution and recovery filters
- Squeegee with their rubbers and hoses
- Brushes

must be carried out using gloves to protect from contact with dangerous solutions.

RECOVERY TANK EMPTYING AND CLEANING

1. Hold the exhaust hose (1) placed in the rear low part of the machine after having taken it off from its fixing support.
2. Take off the plug (2) from the exhaust hose acting upon its lever (3) and empty the recovery tank into appropriate containers, in compliance with the respective rules what the liquid disposal concerns.
3. Take off suction cover (4) after rotating the blocking levers (5).
4. Take off the filter and filter protection (6).
5. Rinse the inside of the tank with a water jet through the hole become free of the filter, paying attention to clean the eventual float switch (7) (optional) and its protection placed right under the hole.
6. Reassemble all parts.

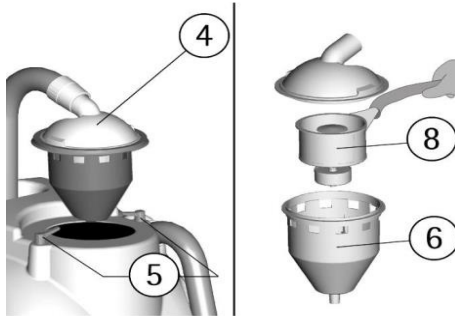
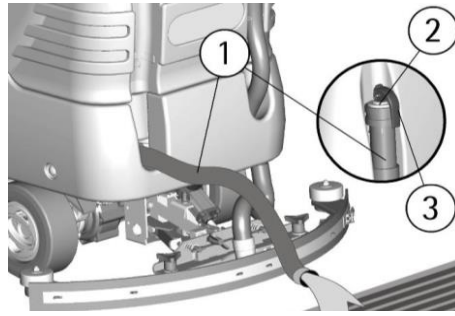

EMPTYING AND CLEANING OF THE COLLECTION BOX

The machine is equipped with a collection box for the solid dirt. At the end of the cleaning operation it is necessary to empty and to clean it with a water jet. For the emptying and the cleaning of the box:

1. Position the selector (10) for the adjustment of the brushes pressure on position P1.
2. Activate the machine (see under paragraph "STARTING OF THE MACHINE") positioning the selector (3) to the right to choose the manual mode (MAN).
3. Activate the push button (17) of up/down of the brushes base to lower the brushes. Once it is lowered, the brushes begin to turn.
4. Turn the key counterclockwise to turn off the machine.



ATTENTION:

To carry out above operations with the electric supply on, may cause damages to hands.

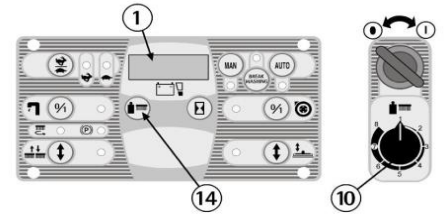

ATTENTION:

This operation must be carried out using gloves to protect from contact with dangerous solutions.

5. Unblock the bar of the side rubber after having released the knob (1).

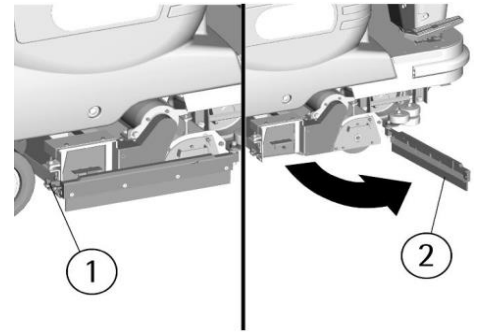

6. Open the bar of the side rubber (2) as shown in the figure.
7. Extract and carry the box by using its handles (3).

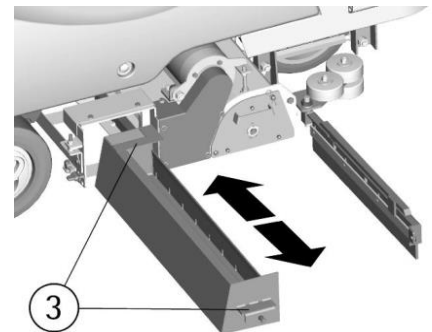

8. Empty the box into appropriate containers, in compliance with the respective rules what the liquid disposal concerns.
9. Put the collection box back into its position up to the end seat.
10. Place the bar of the side rubber (2) into its position blocking it with the knob (1).

SUCTION FILTER CLEANING

1. Take off suction cover (4) after rotating the blocking levers (5).
2. Take off the filter (8) and its filter protection (6).
3. Clean all parts with a water jet and especially the inside surfaces and the filter bottom.
4. Carry out cleaning operations carefully.
5. Reassemble all parts.

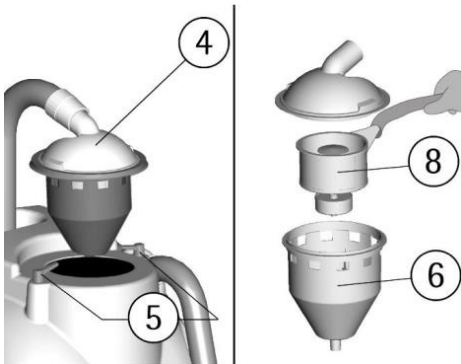

BRUSHES CLEANING

Disassemble the brushes and clean them with a water jet (for the brushes disassembly see under paragraph "BRUSHES ASSEMBLY AND DISASSEMBLY").



ATTENTION:

To carry out brushes disassembly operations with the electric supply on, may cause damages to hands.

SQUEEGEE CLEANING

Keeping the squeegee clean guarantees always the best drying result.

For its cleaning it is necessary to:

1. Take off the squeegee hose (5) from the coupling.
2. Disassemble the squeegee (2) from its support (1) by loosening the knobs (4) counter-clockwise and making slide the threaded parts in the appropriate slots up to their release.

3. Clean with care the internal part of the squeegee inlet eliminating eventual dirt residuals.
4. Clean with care the squeegee rubbers.
5. Reassemble all parts paying attention to put the washers (3) into position, they are two for each knob, so that they are assembled one under and the other on each of the two slots present on the support.

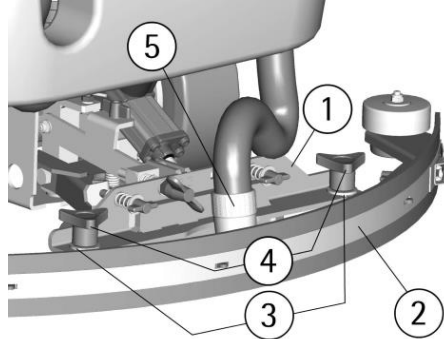

WEEKLY MAINTENANCE

REAR SQUEEGEE RUBBER CHECK

Check the squeegee rubber wear and eventually turn or replace it.

For the replacement it is necessary to:

1. Lift the squeegee (see under paragraph "STOP OF THE MACHINE AFTER CLEANING OPERATION").
2. Release the hook (1) of the rubber holder blade and take off the rubber.
3. Turn the rubber to a new side or replace it.

To reassemble the squeegee reverse the operations mentioned above, inserting the rubber on the guides and blocking it with the rubber holder blade.

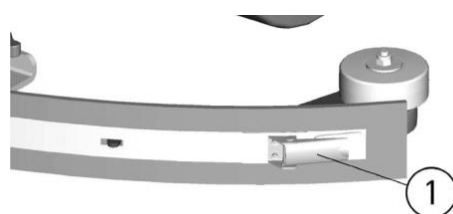

CHECK OF THE SIDE RUBBERS

With the brushes assembled, the side rubbers must touch the floor. If they are worn, they have to be replaced.

To replace the rubbers on both sides of the machine:

1. Unblock the bar of the side rubber after having released the knob (1).
2. Open the bar of the side rubber (2) as shown in the figure.
3. Take off the fixing screws (3) of the rubber blade (4) and replace the rubber.
4. Reassemble all parts.

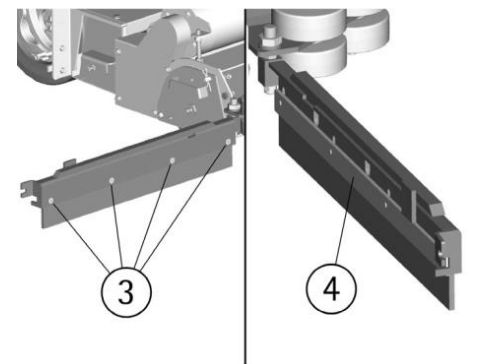
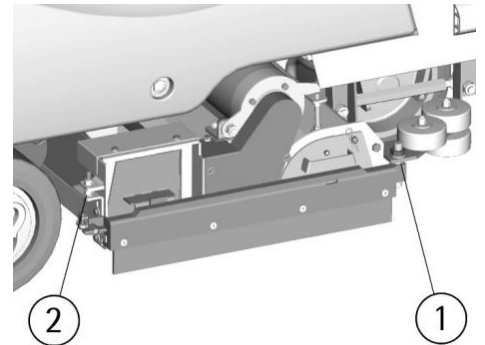

SQUEEGEE HOSE CLEANING

Weekly or in case of insufficient suction, it is necessary to check that the squeegee hose is not obstructed. Eventually, to clean it, proceed as follows:

1. Take off the hose (1) from the squeegee coupling.
2. Wash the inside of the hose with a water jet.
3. To reassemble the hose repeat inversely the above-mentioned operations.

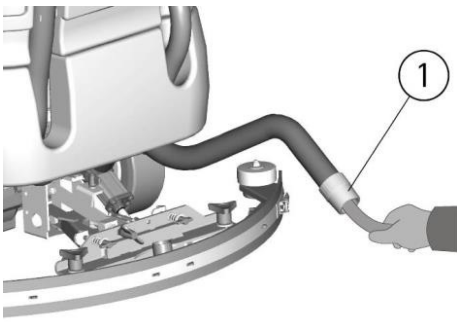

CLEANING OF THE SOLUTION TANK AND OUTER FILTER

1. Bring the machine to an appropriate place to drain the detergent solution
2. Unscrew the solution tank cap (1).
3. Unscrew the cap of the exhaust filter (2) and take off the filter. Be careful not to lose the gasket of the cap.
4. Open the solution valve (see "FLOW ADJUSTMENT OF DETERGENT SOLUTION"), so that the detergent solution flows down into appropriate containers.
5. Rinse the solution tank and the components of the filter with a water jet
6. Reassemble all parts.

NOTE: if needed it is possible to wash only the components of the solution filter as mentioned above by closing the solution valve adjustment (see "FLOW ADJUSTMENT OF THE DETERGENT SOLUTION"), so that the detergent solution remains in the solution tank.

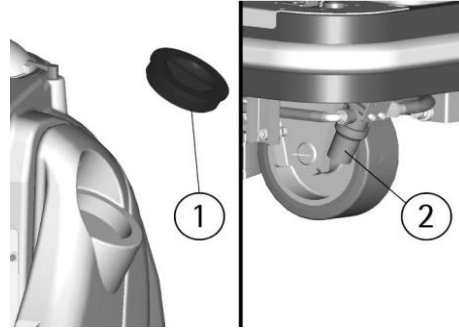

TWO-MONTH MAINTENANCE FRONT SQUEEGEE RUBBER CHECK

- Check the wear of the squeegee rubber and replace it if needed.
- For the replacement:
1. Take off the squeegee (see under paragraph "SQUEEGEE CLEANING").
 2. Unscrew the wing nuts in the front part of the squeegee.
 3. Take off the rubber holder blade.
 4. Replace the front rubber.
 5. Reassemble all parts.

SIX-MONTH MAINTENANCE CLEANING THE INNER FILTER SOLUTION TANK

Empty the solution tank; remove the fitting of the water outlet by taking off the two screws that fix it to the tank in the front part of the machine. Clean the inside filtrating part of the fitting from dirt. Pour some water into the tank to clean it. Reassemble the fitting onto the solution tank.

CHECK THE BRAKE

Check the braking efficiency of both rear wheels. Should the braking be insufficient, please contact an authorized technical assistant.

TROUBLESHOOTING GUIDE



ATTENTION:

If the machine is on, and the display and/or other functions are not activated, check the battery connection of the machine (see "CONNECTING BATTERY' AND SWITCHING ON THE MACHINE"). If the problem persists, please contact an authorized technical assistant.

THE VACUUM MOTOR DOES NOT WORK

1. Verify that the machine is on. If alarm signals appear, turn off the machine and restart it.
2. Check the charge level of the battery on the display (1).
3. Verify that the drying function is activated correctly (see "STARTING THE MACHINE").
4. Check that the recovery tank is not full.
5. Check that the float switch (2) in the recovery tank is assembled correctly.
6. For both in mode (MAN) as (AUTO), if the signal lamp (8) is on but the suction system does not work, it is necessary to rotate the recovery tank (see "ACCESS TO THE BATTERY COMPARTMENT"). Check the connection of the vacuum motor plug at the bottom of the tank. If the problems persist, please contact an authorized technical assistant.

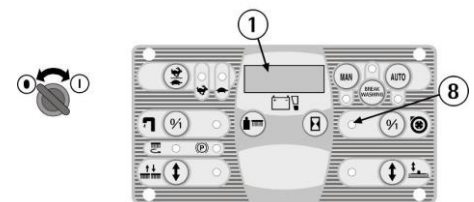

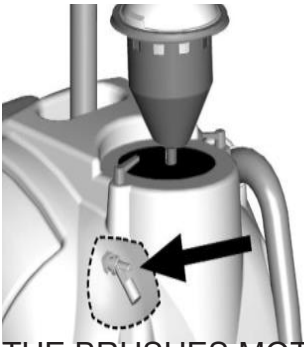

THE BRUSHES MOTOR DOES NOT WORK

1. Verify that the key switch is positioned clockwise to switch on the machine. In presence of alarm signals it is necessary to switch off and on again the machine to restore the functionality.
2. Check the charge level of the batteries on the display (1).
3. Verify of having activated correctly the function of washing with the brushes (see under paragraph "STARTING OF THE MACHINE").
4. If, both in mode (MAN) as (AUTO), the signal lamp (18) is on but the brushes do not turn, please contact the authorized technical assistance.

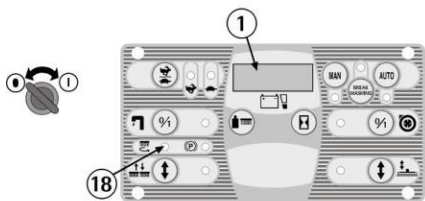

THE TRACTION MOTOR DOES NOT WORK

1. Sit on the seat.
2. Verify that the key switch is positioned clockwise to switch on the machine. In presence of alarm signals it is necessary to switch off and on again the machine to restore the functionality.
3. Check the charge level of the batteries on the display (1).

4. Check through the signal lamp (15) that the parking brake is not inserted and eventually release it (see under paragraph "EMERGENCY-PARKING BRAKE").

5. Press the accelerator pedal placed on the right side to start the machine.

If the problem persists, please contact the authorized technical assistance.

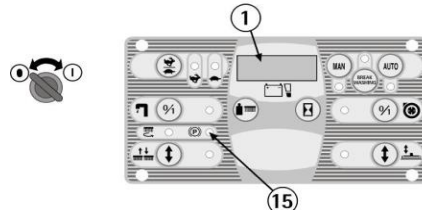

THE WATER DOES NOT COME DOWN ONTO THE BRUSHES OR IS INSUFFICIENT

1. Verify that the key switch is positioned clockwise to switch on the machine.
2. Check the charge level of the batteries on the display (1).
3. Verify of having activated correctly the function of washing with the brushes (see under paragraph "STARTING OF THE MACHINE").
4. Check that the solution valve is open (see under paragraph "FLOW ADJUSTMENT OF THE DETERGENT SOLUTION").
5. If, both in mode (MAN) as (AUTO), the signal lamp (20) is on but the detergent solution does not come down onto the brushes, it is necessary to:
 - a. check the level of the liquid in the tank.
 - b. check that the solution filter is clean (see under paragraph "CLEANING OF THE SOLUTION TANK AND OF THE OUTER FILTER").

c. check that the inner filter of the solution tank is clean (see under paragraph "CLEANING OF THE INNER FILTER SOLUTION TANK"). If the problem persists, please contact the authorized technical assistance.

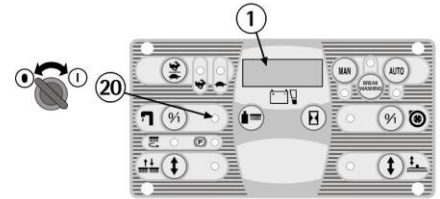

THE MACHINE DOES NOT CLEAN PROPERLY

1. The brushes do not have the suitable bristle dimension: contact the authorized technical assistance.
2. The brushes have got worn bristles. Check the brushes wear condition and eventually replace them. To replace the brushes, see instructions under paragraph "BRUSHES DISASSEMBLY" and "BRUSHES ASSEMBLY".
3. The detergent solution is insufficient: open more the solution valve (see under paragraph "FLOW ADJUSTMENT OF THE DETERGENT SOLUTION").
4. Check that the liquid detergent is in the recommended percentage.
5. Increase the brushes base pressure (see under paragraph "ADJUSTMENT OF THE BRUSHES PRESSURE"). Contact the authorized technical assistance for advice.

THE SQUEEGEE DOES NOT DRY PERFECTLY

1. Check that the suction function is on and that the recovery tank is not full.

2. Check that the squeegee rubbers are clean (see under paragraph "SQUEEGEE CLEANING").

3. Check the adjustment of the height and the inclination of the squeegee (see under paragraph "ADJUSTMENT OF THE SQUEEGEE").

4. Check that the suction and the squeegee hoses are correctly inserted in their proper seats on the recovery tank.

5. Clean the suction filter (see under paragraph "SUCTION FILTER CLEANING").

6. Clean the squeegee hose (see under paragraph "SQUEEGEE HOSE CLEANING").

7. Replace the rubbers if worn out.

EXCESSIVE FOAM PRODUCTION

Check that low foam detergent has been used. Eventually add small quantities of anti foam liquid into the recovery tank. Please be aware that a bigger quantity of foam is produced when the floor is not very dirty. In this case please dilute detergent solution.

PROGRAMMED MAINTENANCE

INTERVENTION	DAILY	20 HOURS *	200 HOURS *	1000 HOURS *
RECOVERY TANK CLEANING	•			
SUCTION FILTER CLEANING	•			
SOLUTION TANK FILTER CLEANING		•		
BRUSH CLEANING	•			
BRUSH DISASSEMBLY AND CLEANING	•			
SQUEEGEE CLEANING	•			
FRONT SQUEEGEE RUBBER REPLACEMENT			•	
REAR SQUEEGEE RUBBER REPLACEMENT		•		
SIDE RUBBER REPLACEMENT			•	
CHECK SQUEEGEE ADJUSTMENT		•		
SQUEEGEE HOSE CLEANING		•		
SOLUTION TANK CLEANING		•		
CHECK BATTERIES ELECTROLYTE		•		
CHECK BRAKE				•
TRACTION MOTOR CHECK				•
BRUSH MOTOR CHECK				•
VACUUM MOTOR CHECK			•	
CHECK BRUSH BASE GROUP			•	
SCREW TIGHTENING				•

* The hours refer to the ones indicated on the display (see under paragraph "HOUR METER").

RECOMMENDED BRUSHES

Brushes must be chosen depending on type of floor and dirt to be removed. The employed material and the bristles diameter are the elements that distinguish different types of brushes.

MATERIAL	CHARACTERISTICS
PPL (Polypropylene)	Good wear resistance. Maintains characteristics with hot water up to 140°F (60°C). It is not hygroscopic.
NYLON	Excellent wear resistance, even with hot water over 140°F (60°C). It is hygroscopic. It loses its physical characteristics over the time.
TYNEX	Nylon bristles with grains of abrasive material. Use with caution in order not to mark the floor or ruin the polishing.
BRISTLES THICKNESS	Thicker bristles are more rigid and must be used on smooth floor or floor with small joints. On irregular floors with deep joints or relieves, it is recommended to use softer bristles which penetrate more easily and deeper. Please be aware that when brush bristles are worn out and therefore too small, they become rigid and unable to penetrate and clean deeper. This may also happen with thicker bristles creating brush vibration.

CODE	QTY	DESCRIPTION	USE
48906020	2	Cylindrical brush PPL 0,7 Ø (6" x 26") (150 x 800)	Smooth floors with small joints and persistent dirt.
48906060	2	Cylindrical brush PPL 1 Ø (6" x 26")	Floors of resistant material and particularly dirty.
48906080	2	Cylindrical brush TYNEX Ø (6" x 26")	Floors of resistant material and particularly dirty.
48906100	2	Cylindrical brush PPL 0,3 Ø (6" x 26")	Smooth floors with small joints and persistent dirt.

Warranty Registration Form

Please provide additional information on
Tornado equipment: (Check choices below)

- | | |
|---|---|
| <input type="checkbox"/> Automatic Scrubbers | <input type="checkbox"/> Sweepers |
| <input type="checkbox"/> Propane Floor Machines | <input type="checkbox"/> Rotary Floor Machine |
| <input type="checkbox"/> High Speed Burnishers | <input type="checkbox"/> Carpet Vacuums |
| <input type="checkbox"/> Carpet Extractors & Spotters | <input type="checkbox"/> Wet/Dry Vacs |
| <input type="checkbox"/> Steam Cleaners | <input type="checkbox"/> Jumbo Vacs |
| <input type="checkbox"/> Ride-On Equipment | <input type="checkbox"/> Pressure Washers |

See complete product info at www.tornadovac.com

Selling Dealer: (Required) _____

Please Print Clearly

Company/Institution	
Contact Name	Title
Address	City/State/Zip Code
Phone	Fax
Date of Purchase	Email

See white metal plate or sticker on unit for this information.

MACHINE TYPE/MODEL NUMBER:	MACHINE SERIAL NUMBER:
1. _____	1. _____
2. _____	2. _____
3. _____	3. _____
4. _____	4. _____

Facility Description (please circle all that apply)

1. School	9. Hospital	17. U.S. Govt.
2. Retail Store	10. Nursing Home	18. Other Govt.
3. Restaurant	11. Religious Institution	19. Auto Service
4. Office Building	12. Airport	20. Airport
5. Contract Cleaning	13. Warehouse	21. Non-Profit
6. Light Manufacturing	14. Apartment/Condo	22. Other (specify)
7. Heavy Manufacturing	15. Warehouse	
8. College/University	16. Supermarket	

How did you first learn about Tornado cleaning and maintenance equipment?	In square feet (<i>meters</i>)	
	Total Hard Floor Area	Total Carpeted Area Square feet (square meters)
<input type="checkbox"/> Contacted by local dealer <input type="checkbox"/> Previous experience with Tornado products <input type="checkbox"/> Reputation/ Recommendation <input type="checkbox"/> Advertising <input type="checkbox"/> Direct mail <input type="checkbox"/> Internet <input type="checkbox"/> Other	<input type="checkbox"/> 0-10,000 (0-930) <input type="checkbox"/> 10-50,000 (930-4,650) <input type="checkbox"/> 50-250,000 (4,650-23,250) <input type="checkbox"/> Over 250,000 (over 23,260)	<input type="checkbox"/> 0-10,000 (0-930) <input type="checkbox"/> 10-50,000 (930-4,650) <input type="checkbox"/> 50-250,000 (4,650-23,250) <input type="checkbox"/> Over 250,000 (over 23,260)

Damage or defect arising from abuse, neglect or other misuse is excluded from this warranty. Other items may or may not apply based on your specific machine. If any defect occurs, the warranty is voided if service is attempted by non-Authorized Tornado Service Centers.



Return to :
Tornado Industries
3101 Wichita Court
Fort Worth, TX 76140
Fax: 817-551-0719
or online at
www.tornadovac.com