

# **Powr-Flite**<sup>®</sup>

## **OPERATOR'S MANUAL & PARTS LIST**

### **Automatic Scrubber PAS14G**



**WARNING: OPERATOR MUST READ AND UNDERSTAND THIS MANUAL  
COMPLETELY BEFORE OPERATING THIS EQUIPMENT.**

**Save These Instructions**

## Contents

Getting to know the machine .....	3
1. Product Information .....	4
1.1 Important Safety Advice.....	4
1.2 Non intended use of the machine .....	4
1.3 General warnings about batteries .....	4
1.4 Guidelines for the operator.....	5
1.5 Transporting the machine .....	5
1.6 Symbols & Markings .....	5
1.7 Electrical connection.....	5
2. Preparing for use .....	5
2.1 Connecting the batteries .....	5
2.2 Charging the batteries.....	6
2.3 Adjusting the handle height.....	6
2.4 Attaching the brushes and pads .....	6
2.5 Filling the solution tank.....	7
3. Controls .....	7
4. Operation.....	8
4.1 Checks before use.....	8
4.2 Preparing the machine and choosing the cycle .....	8
4.3 Using the machine.....	9
5. Warnings while using the machine.....	9
5.1 When cleaning is finished.....	9
5.2 Draining and cleaning the recovery tank.....	10
5.3 Draining and cleaning the solution tank.....	10
5.4 Cleaning the squeegee blades.....	10
6. Storage.....	10
6.1 Prolonged machine standstill .....	11
7. Maintenance .....	11
7.1 Replacing the squeegee rubber blades .....	11
7.2 Squeegee set up (correct position) .....	12
7.3 Replacing the fuses (Fig 23).....	12
7.4 Operations to perform weekly.....	12
8. After Sales Service .....	13
9. Guarantee .....	13
11. Technical specification .....	14
12. Accessories.....	14
13. Fault diagnosis.....	15

## Getting to know the machine

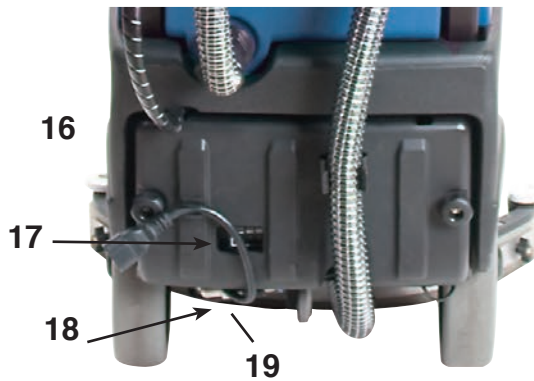
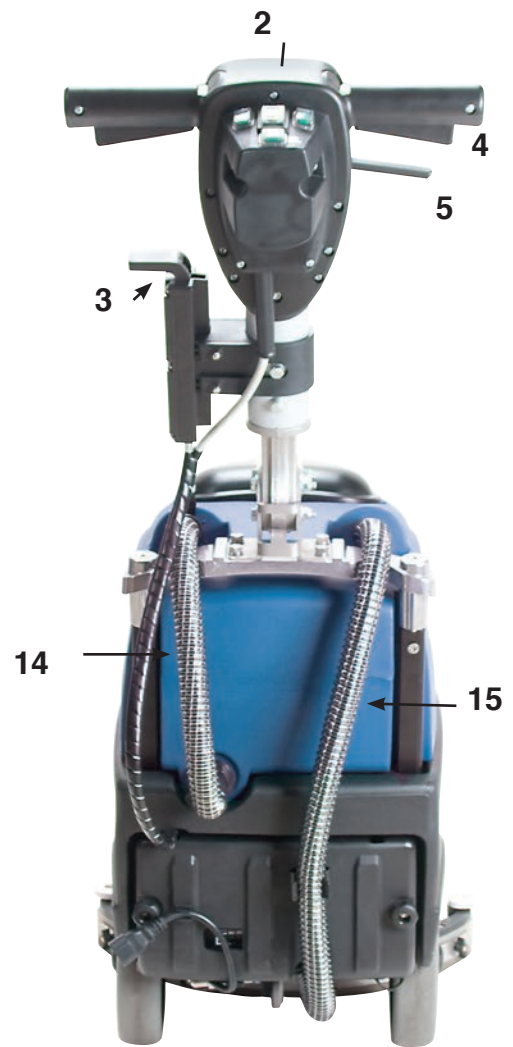

1. Handle
2. Control panel
3. Squeegee lifting lever
4. Lever for starting brush rotation and/or dispensing water
5. Handle adjusting lever
6. Recovery tank
7. Recovery tank lid
8. Solution tank
9. Solution tank filling opening
10. Wheels

11. Brush guard
12. Brush
13. Squeegee
14. Recovery tank drain hose
15. Vacuum hose
16. Battery charger lead
17. Battery charger indicator
18. Water regulation tap
19. Water filter

## 1. Product Information

This commercial automatic scrubber is designed for the scrubbing/cleaning of hard floors in indoor areas.

Maintenance free (gel) batteries must be used. A battery life indicator allows the operator to check the degree of battery life available, and an on board battery charger provides convenient charging.

This machine must only be used for the manufacturer's approved application. Using the machine for any other purpose will void the warranty. **Do not use** the machine where it is suspected that the floor contains health endangering dust or debris such as asbestos or chemical waste. If this is suspected **do not proceed**, contact your supervisor.

The following instructions contain important information about the machine and safety advice for the operator.

Equipment must be operated, serviced and maintained in accordance with the manufacturer's instructions. **If in doubt contact the supplier of your machine.**

### 1.1 Important Safety Advice

When using electrical equipment basic safety precautions should be followed.

- Read all instructions carefully before use.
- Please note that the safety information described in the manual supplements and does not replace local, state, and federal regulations or those standards in force in the country in which the machine is used.
- This appliance is suitable for commercial use. For example in hotels, schools, hospitals, factories, shops, offices, rental businesses and other than normal housekeeping purposes.
- This machine is not intended for use by children or people with reduced physical, sensory or mental capabilities, or lack of experience and knowledge, unless they have been given supervision or instruction concerning use of the machine by a person responsible for their safety.
- Keep children and unauthorized persons away from the machine when in use.
- Before using the appliance, check that the main power supply voltage corresponds with the voltage shown on the rating plate.
- All parts are to be positioned as indicated in the instructions before using the machine.
- Do not operate the machine if it malfunctions or is damaged in any way. Contact an authorized service agent for repair or adjustment.
- Do not operate switches or touch the power cord plug with wet hands as this may cause electric shock.
- When unplugging pull on the plug, not the power cord.
- Do not pull or carry by cord, use cord as a handle, close a door on cord, or pull cord around sharp edges or

corners.

- Keep hair, loose clothing, fingers and all parts of body away from openings and moving parts.
- Keep cord away from heated surfaces.
- Do not use where hazardous dust is present.
- Do not use in an explosive atmosphere.
- Do not pick up oil or other flammable material.
- Do not operate the machine while plugged in.
- The battery charging lead must be inspected regularly for signs of damage. If the lead is damaged, it must be replaced by the manufacturer, its service agent or a similar qualified person in order to avoid a hazard.
- Replace the supply cord only with the type specified in the instruction manual.
- Do not charge the machine with a damaged battery charging lead or plug, or after the machine malfunctions or is damaged in any way. Contact an authorized Service Agent for repair or adjustment.
- Do not charge the machine with a damaged battery charging lead or plug, or after the machine malfunctions or is damaged in any way. Contact an authorized service agent for repair.
- When re-charging ensure the area is sufficiently ventilated.
- Take care when using a machine near the top of stairs to avoid overbalancing.

### 1.2 Non intended use of the machine



#### WARNING

- Washing floors with water which is hotter than 122°F
- Using diesel/gas or corrosive detergents to wash floors
- Washing and sucking up corrosive, flammable and/or explosive liquids, even if diluted.

### 1.3 General warnings about batteries



**WARNING** Use appropriate personal protection equipment to avoid contact with the skin (see standards in force in the country in which the machine is used).

- Do not inhale the vapour, it is dangerous.
- Do not smoke and/or use naked flames within 7 feet of the battery during charging, in the charging area and while the battery is cooling after charging.
- Report any liquid leaking from the battery. Leaks are dangerous and highly polluting.



**WARNING** In case of fire, use approved Class B or C dry chemical powder extinguishers only. Do NOT use water to put out the fire.

## 1.4 Guidelines for the operator



### WARNING

Operators must be fully trained in the use of the machine in accordance with these instructions, able to perform user maintenance and the correct selection of accessories.

- Operators should be physically capable to maneuver, transport and operate the machine.
- Operators should be able to recognize unusual operation of the machine and report any problems.
- Only use the machine on firm level surfaces, with no more than a 2% slope.
- Wear suitable footwear to avoid slipping.
- Wear suitable clothing to keep dry and warm.
- Where possible implement job rotation and adequate rest periods to avoid continuous use of the same muscles.
- Do not leave machine running unattended
- Do not smoke when using the machine.
- Do not put any objects into openings. Do not use with any opening blocked. Keep openings free of dust, debris, hair, or anything that may reduce air flow.
- Keep hands and feet well clear of rotating pads and brushes.



**CAUTION** - This machine is for indoor use only and should not be used or stored outdoors or in wet conditions.



**CAUTION** - If it is suspected that there is hazardous dust or flammable materials stop cleaning the area immediately and consult your supervisor.



**WARNING** Only use accessories and spare parts provided with the machine or those approved by the manufacturer. The use of other accessories may impair the safety of the machine and void the warranty.



**WARNING** The machine must be switched off before adding or changing accessories.

## 1.5 Transporting the machine



### CAUTION - THIS MACHINE IS HEAVY

Do not attempt to lift the machine without mechanical assistance.



**CAUTION** – Incorrect lifting techniques may result in personal injury. Do not lift large and heavy machines without assistance. Please refer to the specifications page for details on weight of machine.

When transporting the machine, be sure that all components, tanks and removable parts are securely fastened, and that the battery charging cord and plug are not trailing.

To move the machine to the work area lock handle and tilt backwards to raise the front off the floor, and wheel into position.

**CAUTION** – Bumping over thresholds, curbs and similar obstacles can damage the machine. Pull the machine backwards to go over small obstacles.

## 1.6 Symbols & Markings

In order to highlight information and procedures regarding safety, maintenance etc, the following symbols have been adopted in the manual:



**WARNING**



**GROUNDED SYMBOL**

## 1.7 Electrical connection

Before connecting the machine to the power supply, check that your supply voltage matches the rating on the machine label.

**IMPORTANT** - If the battery charging lead is damaged, it must only be replaced by an approved cord available from the manufacturer or an authorized service agent.

**WARNING – THIS APPLIANCE MUST BE GROUNDED**



## 2. Preparing for use

### 2.1 Connecting the batteries

- Unscrew the bolts that fasten the tank to the handle support (Fig 1).



Fig 1

- Remove the recovery water tank (Fig 2).



Fig 2

- Connect the battery connectors (Fig 3 & 4).



Fig 3

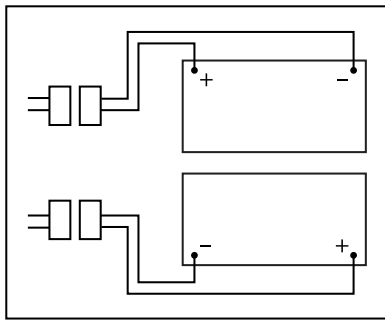

Fig 4

- Replace the recovery water tank and screw into place.

**WARNING** Make sure that the building power supply is equipped with GFI (circuit breaker).

## 2.2 Charging the batteries

**WARNING** Charge batteries in a well ventilated area which complies with local, state and federal regulations and with standards in force in the country of use.

- Move the machine close to a electrical socket.
- Unwind the battery charging lead at the rear of the machine and connect to the outlet.

**WARNING** Check that the building power supply matches the operating voltage of the battery charger (100 – 120V, 50/60Hz).

- Let the batteries charge until the “Green” LED comes on, then remove the plug and wind the battery charging around the cable holder (Fig 5).

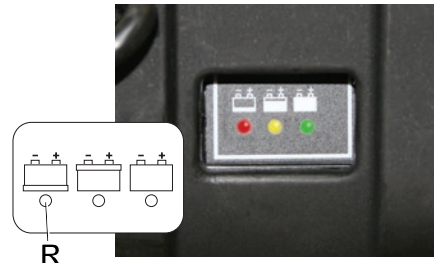

Fig 5

**NOTE:** 10 hours are required for complete battery charge.

- IMPORTANT** - Overcharging will damage the batteries. This will cause run time to be reduced and overall battery life will be affected. **AVOID OVER CHARGING.**

## 2.3 Adjusting the handle height

Select the most comfortable handle height using the adjustment lever (#6 on Fig 10) on the handle. Release the lever and lock in position.

## 2.4 Attaching the brushes and pads

**WARNING** – This appliance has been designed for use with quality brushes and pads only. The use of inappropriate brushes and pads may affect its performance and safety.

**WARNING** Be sure the machine is switched off before adding or changing accessories.

- The solution tank and recovery tank must be empty prior to changing brushes/pads.
- Ensure handle is in upright position and the squeegee is in the up position.
- Carefully lift the front of the machine to expose the clutch plate (Fig 6).

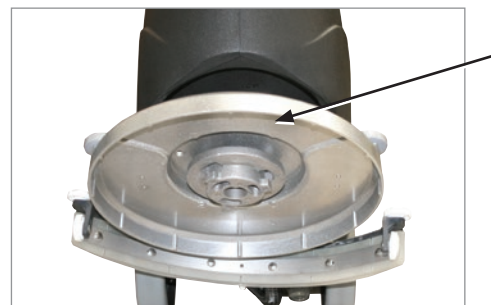

Fig 6

- Attach the brush/drive disc onto the clutch plate and rotate the brush/drive disc until secure (Fig 7).
- Return the machine in the upright position.



Fig 7

**IMPORTANT** Never allow the cleaning head to rest on the brush or drive disc and pad when not in use.

### 2.5 Filling the solution tank

**WARNING** Only add clean water to the tank at a temperature no greater than 122° F.

- Remove the filter from the solution tank opening.
- Connect one end of the filling hose to a faucet and insert the other end in the solution tank (Fig 8).



Fig 8

- Turn on the faucet and fill the tank.
- Pour the liquid detergent into the tank.

**IMPORTANT** - Only chemicals recommended by the appliance manufacturer should be used, i.e. non foaming. Follow the chemical manufacturer's directions regarding use, handling and health and safety warnings.

 **WARNING** If the chemical comes in contact with the eyes and/or skin or is swallowed, refer to the MSDS information provided by the manufacturer of the chemical.

After the tank is filled, remove the filling hose and reinsert the filter into the tank opening.

- The tank capacity is 4.5 gal. Do not overfill the tank as spills may occur when in use.
- **IMPORTANT** - When the solution tank has emptied, switch off the machine and empty the recovery tank

before refilling the solution tank.

### 3. Controls

The operating controls are located on the handle. (Fig 9). The icons adjacent to each switch identify the functions.

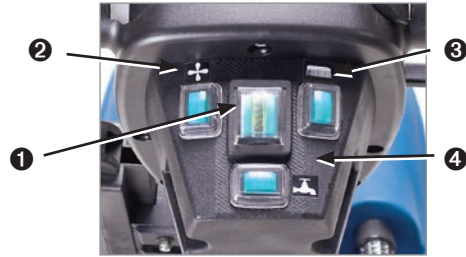
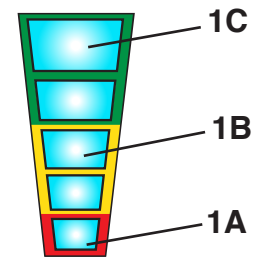

Fig 9

#### 1 - LEDs status of battery charge

The LED lights will indicate the charging status.

Green LED (1c)	maximum.
Yellow LED (1b)	half
Red LED (1a)	minimum



When the battery is completely discharged, (Red LED (1c) of the battery charger flashes for a few seconds. At this point the battery requires recharging.

#### 2 – Vacuum motor switch

Used to switch the vacuum motor ON and OFF. Provides suction at the squeegee. Button illuminated when in the on position.

#### 3 – Brush motor switch

Used to switch brush motor ON and OFF. Button illuminated when in the on position.

To start the brush rotating press the lever on the right hand side.

#### 4 – Water dispensing button

The solution is controlled by pressing both switch 3 and by pressing the lever used to dispense solution for scrubbing. Button is illuminated when on. (#5, Fig 10)



Fig 10

### 5 – Brush rotating and/or water dispensing lever

Pressing and holding lever 5 will start the rotation of the brush. Cleaning solution will be dispensed if button 4 (Fig 9) is on. The left or right lever can be used. (Fig 10).

### 6 - Handle adjustment lever

Used to adjust handle to comfortable working height.

## 4. Operation

### 4.1 Checks before use

- Check that the drain hose tube of the recovery tank is properly coupled and sealed.
- Check that the squeegee vacuum hose is correctly coupled and inserted in the recovery tank (See Fig 11).



Fig 11

- Check that the connector (#3, Fig 12) on the squeegee is not blocked and that the hose is connected correctly.

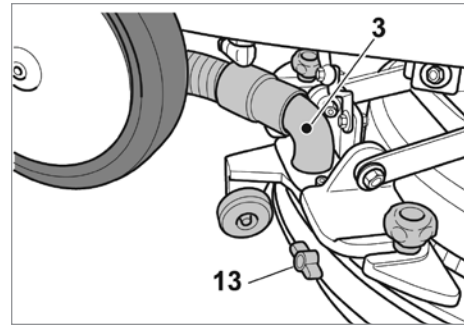

Fig 12

- Check the status of the battery charge by pressing brush switch 3. (Fig 9)
- Check that the water filter is clean and free of debris (Fig 13).



Fig 13

### 4.2 Preparing the machine and choosing the cycle

- Press the brush motor button (#3, Fig 9). The light illuminates.
- Pull the squeegee lifting lever and release it to lower the squeegee to the floor (Fig 14).



Fig 14

The machine can perform 4 working cycles:

- **Drying only cycle**  
Press and hold lever 5 (Fig 10) for brush rotation; then press button 2 (Fig 9) to start the vacuum.
- **Brushing only cycle**  
Press and hold lever 5 (Fig 9). Releasing the lever stops the brush.
- **Washing, brushing cycle:**  
Press button 4 (Fig 9) to enable dispensing of solution. Press lever 5 (Fig 10) to release solution onto floor.



#### • Washing, brushing, drying cycle

Press button 2 to start the vacuum, button 4 (Fig 9) to release solution and press the lever 5 (Fig 10) to start the cycle.

### 4.3 Using the machine



**WARNING!** Never start the machine without a brush or pad attached.

- Set the handle set at a comfortable working height.
- Start the machine and select the type of cycle. Start the cleaning operation by pressing the levers and holding them pressed to start rotation of the brush or pad and to dispense cleaning solution, then push the machine in a forward direction using handles on the handle bar.
- Releasing the lever stops the rotation of the brush and the dispensing of solution.



**WARNING** – to avoid damaging the floor DO NOT use the machine in a fixed position with the brush rotation activated. The machine must be moving while the brush is rotating.

- **IMPORTANT** – the correct way of cleaning and drying the floor is to move the machine forward. Moving the machine backwards damages the blades and does not allow water to be vacuumed from the floor.
- If necessary, adjust the volume of solution using the tap (See pic 15 & 16).



Fig 15 Solution tap fully opened

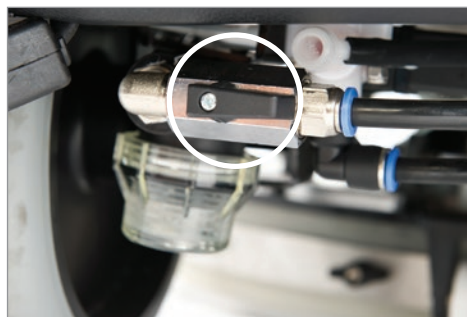

Fig 16 Solution tap fully closed

- Check the status of the battery charge by the indicator (pic).
- Proceed to operate the machine in the normal manner, releasing cleaning solution from time to time as required.
- For heavy soil, scrub floor with cleaning solution but

with vacuum motor OFF. Scrub floor again, picking up the solution.

- **WARNING** - If foam or liquid is leaking, turn machine off immediately and empty recovery tank. Leaking liquid could be hazardous due to its temperature, or chemical content.
- To STOP the machine, release solution feed levers, switch off brush motor then vacuum motor.

**IMPORTANT! If it is necessary to replace the brush or pad during cleaning please follow instructions in section 2.4.**

### 5. Warnings while using the machine

- While using the machine, errors are indicated by flashing and lit LEDs
- LED 1 is flashing and LED 2 is constantly lit – Suction unit outlet overcurrent.
- LED 1 is flashing and LED 3 is constantly lit – Brush unit outlet overcurrent.
- LED 1 is flashing and LED 4 is constantly lit – Suction unit outlet open circuit.
- LED 1 is flashing and LED 5 is constantly lit – Brush unit outlet open circuit.

Fig 17

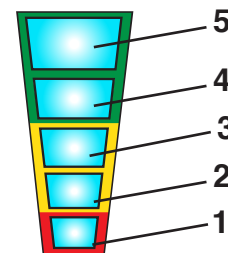

**NOTE:** When any of the above mentioned error signals are displayed, it is necessary to turn off the machine and then turn the machine back on again in order to clear the error and re-set the machine back to normal functioning.

#### 5.1 When cleaning is finished

- Before turning off the machine, stop the dispensing of solution and the rotation of brushes by releasing levers. Continue with the vacuum ON to remove all of the liquid present on the floor. Then turn off the vacuum by pressing button 2. (Fig 9)
- Raise the squeegee by pulling the squeegee lifting lever and releasing it. The lever remains in an upper position keeping the squeegee blades in the raised position.

**WARNING** – always lift up the squeegee at the end of the cleaning in order to prevent the deformation of the rubber blades.

- Remove brush or pad from machine and wash in warm soapy water.

## 5.2 Draining and cleaning the recovery tank

At the end of the cleaning cycle or when the recovery tank is full, it is necessary to empty the tank by proceeding as follows:

- **IMPORTANT** – To dispose of the solution in the recovery tank, comply with the local, state, and federal standards in force in the country in which the machine is being used.
- Position the machine near a drain outlet.
- Disconnect the hose from the support on the back of the machine.
- Remove the cap from the hose and drain all water from the tank (Fig 18).



Fig 18

**WARNING!** After each use, it is necessary to clean the recovery tank to prevent deposits or scaling and the growth of bacteria, odors or mold.

- Remove the cover, and clean the inside of the cover and the vacuum safety float with running water.
- Leaving the hose lowered and the cap off, run water through the upper opening, cleaning the inside of the tank until clean water comes out of the drain hose.
- Replace all components in reverse order.

## 5.3 Draining and cleaning the solution tank

**WARNING!** – After each use, it is necessary to drain and clean the solution tank to prevent deposits or scaling.

- Position the machine over a drain outlet.
- Turn the drain connector outwards (Fig 19).

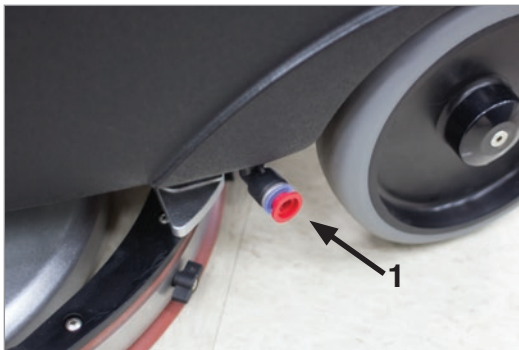

Fig 19

- Push the hose clip (1) inwards while removing the cap,

letting all the water drain out.

- Wash the inside of the tank, leaving the drain cap open and adding clean water through the front opening.
- After cleaning, replace the cap, pushing inwards.
- **IMPORTANT** – To dispose of unused cleaning solution, comply with the local, state, and federal standards in force in the country in which the machine is being used.

## 5.4 Cleaning the squeegee blades

To clean the squeegee correctly (1) it is necessary to remove it as follows (Fig 20):

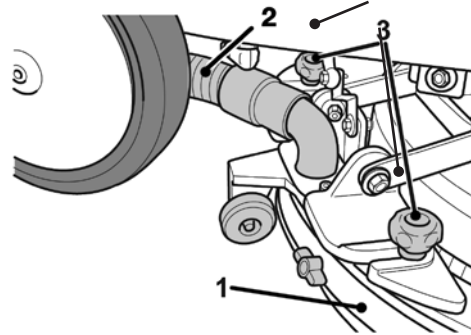

Fig 20

- Pull the squeegee unit outwards (1).
- Disconnect the hose (2) from the squeegee (1).
- Loosen the knobs (3) and remove the squeegee (1)

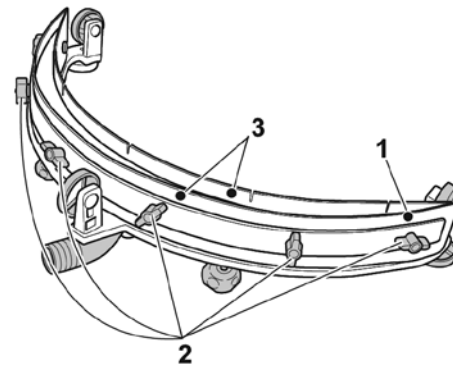

Fig 21

- Wash the squeegee unit, and specifically the rubber blades (4) and the inside of the vacuum hose connector (5). (Fig 21)

**If the rubber blades are damaged or worn, it is necessary to replace them or turn them over.**

## 6. Storage

- Always switch off, empty, wipe down and dry the machine after use.
- The solution tank and recovery tank must be emptied and flushed out with clean water.
- Wrap the battery charger cord around the cable winder, ensuring that the plug is not trailing on the floor.

- When storing the machine for long periods, remove the brush and put the squeegee in the upright position.
- Store the machine in a dry indoor area only.

### 6.1 Prolonged machine standstill

- Drain the clean water contained in the tank.
- Place the machine under cover, sheltered from atmospheric agents in a place where the temperature is between 40°F and 105°F.
- Charge the batteries and, once they are charged, disconnect them from the charger. Refer back to section 2.1 and follow in reverse order.
- Charge the batteries once a month.

### 7. Maintenance



**WARNING - Before making adjustments or performing maintenance, switch off the machine, unplug from the power supply and disconnect the non-grounded pole of the battery.**

- Do not rest tools and metal objects on the batteries; danger of short circuits.
- Do not use harsh detergents, acid, lye etc. during cleaning and washing. Take particular care with electrical parts.
- Do not wash the machine with direct or pressurized jets of water.
- When the machine must be lifted for any maintenance operations, it is necessary to work safely by placing fixed supports underneath it.
- Contact an authorized support center for repairs and request ORIGINAL spare parts only.  
The machine requires minimal maintenance apart from the following checks by a trained operator.
- **Battery charge cord** - Regularly inspect sheath and plug for damage or loose connections. Replace the supply cord only with the type specified in these instructions.
- **Recovery tank** – Check condition and clean tank
- **Squeegee blades** – Check condition and replace worn or damaged blades.

### 7.1 Replacing the squeegee rubber blades (Fig 21).

When it becomes clear that drying the floor is difficult or traces of water remain on the floor, it is necessary to check the wear on the squeegee rubber blades (3):

- Remove the squeegee unit (1) as indicated in the “Cleaning the squeegee” section 5.4.
- Loosen the finned nuts (2) and remove the rubber blades (3).

**NOTE:**

*When the rubber blades (3) are worn on one side, they may be turned over one time.*

- Replace or turn over the rubber blades (3) without

inverting them.

- Replace all the components in reverse order.

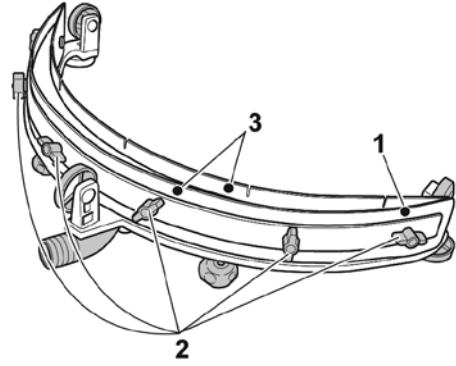

Fig 21

**NOTE:**

It is possible to have two types of rubber blades. Para rubber blades for all types of floors and polyurethane rubber blades for mechanical workshop floors which are dirty with oil.

### 7.2 Squeegee set up (correct position) (Fig. 22)

- Lower the squeegee using the squeegee lever.
- Start the vacuum and move forward several feet before stopping the suction unit and the machine.
- Check the angle of the rubber blades (1) on the floor.  
Fig. A = too low  
Fig. B = too high  
Fig. C = correct position
- Remove the squeegee unit from the machine
- To reposition the blade, loosen the screw (2) of the wheel (3) and move the wheel vertically in the slot lifting or lowering the wheel, to achieve the correct position (C).

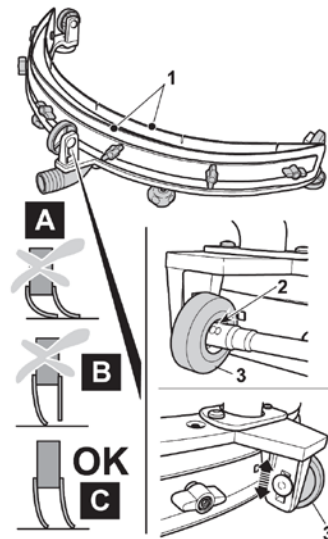
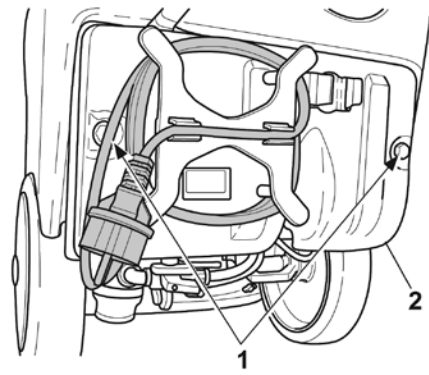

Fig 22

### 7.3 Changing the brushes or pad drivers (Fig 23)

- Lift the machine up slightly at the front
- Press the brush rotation button (3) to enable the rotation of the brush, then press lever (5) and release it; the brush becomes disconnected (Fig 23)



### 7.4 Replacing the fuses (Fig 24)

**WARNING** Replace the blown fuse with one with the same amperage.

- Unscrew the two bolts (1) that fasten the external box (2) and remove it.
- Unscrew the two bolts (3) of the printed circuit board (4) and remove it.
- Replace Fuse (5) Green 30A
- Reverse steps above to replace components after fuse is replaced.

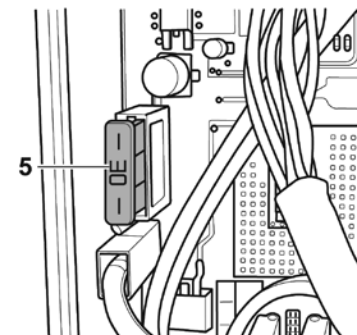
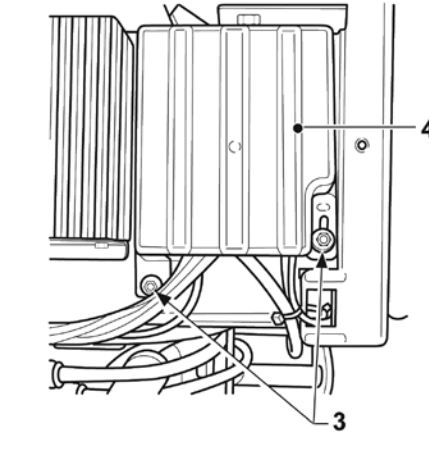

Fig 24

## 7.5 Operations to perform weekly Cleaning the clean water filter (Fig. 25)

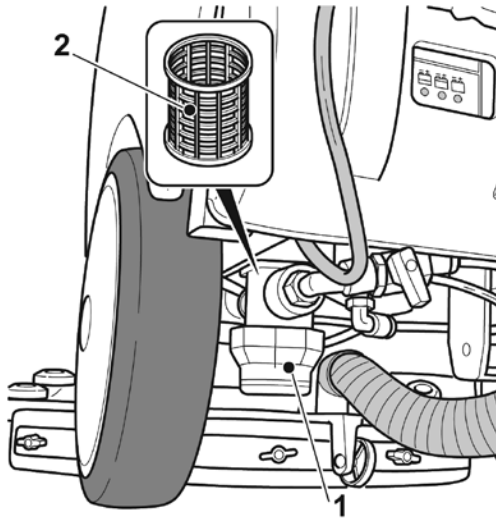

Fig 25

- Make sure that the solution tap is fully closed. Refer to Fig 16.
- Unscrew the transparent filter cover (1) and remove the filter (2).
- Clean the filter (2) in running water. If it is blocked, replace it.
- Replace all the components in reverse order.

**IMPORTANT** – All other servicing and repairs should only be performed by a Powr-Flite engineer or Authorized Service Agent.

**IMPORTANT** – Should the machine fail to operate please refer to the fault diagnosis section (13) in the back of the instruction manual. If the problem / remedy is not listed please contact Powr-Flite Technical Service Department.

## 8. After Sales Service

Powr-Flite machines are high quality machines that have been tested for safety by authorized technicians. It is normal that after longer working periods, electrical and mechanical components will show signs of wear and tear or aging.

Under extreme or specialized conditions and/or insufficient maintenance, shorter maintenance intervals are necessary. Use only original Powr-Flite spare parts.

**Use of other spare parts will invalidate all warranty and liability claims.**

Should you require after sales service please contact Powr-Flite or the supplier from whom you purchased the machine. Powr-Flite will arrange service. Repairs and servicing of Powr-Flite products should only be performed

by trained staff. Improper repairs can cause considerable dangers to the user.

## 9. Guarantee

Your product is guaranteed for one year from the date of original purchase, against defects in materials or workmanship during manufacture. Within the guarantee period we undertake at our discretion, to repair or replace free of charge to the purchaser, any part found to be defective, subject to the following conditions.

### CONDITIONS

1. Claims made under the terms of the guarantee must be supported by the original invoice/bill of sale issued at the time of sale, or the machine Serial Number.
2. For claims under this guarantee contact Powr-Flite or the supplier from whom you purchased the product. Do not initially return the product as this could result in transit damage.
3. Neither Powr-Flite nor its distributors shall be liable for any incidental or consequential loss.
4. This guarantee does not cover any of the following:
  - Periodic maintenance, and repair or replacement of parts due to normal wear and tear.
  - Damage caused by accident, misuse or neglect, or the fitting of other than genuine Powr-Flite parts.
  - Defects in other than genuine Powr-Flite parts, or repairs, modifications or adjustments performed by other than a Powr-Flite service engineer or authorized service agent.
  - Costs and risks of transport relating directly or indirectly to the guarantee of this product.
  - Consumable items and wear parts such as drive belts.

## 11. Technical specification

Class I construction. Enclosure to IPX3.

Model		Predator 14 Battery Scrubber
Charging voltage AC (~) / Frequency	V / Hz	100 – 120 / 50 – 60
Voltage DC	V	24
Charging time	hours	10
Run time	hours	1 hour 20 minutes
Brush/cleaning width	in	14
Drying width	in	16
Brush pressure	g/cm <sup>2</sup>	35
Brush speed	rpm	130
Theoretical hourly working capacity	m <sup>2</sup> /hour	10,400
Solution tank capacity	gal	4.5
Recovery tank capacity	gal	6.8
Brush motor rating	W	260
Vacuum motor rating	W	250
Air flow	l/sec	28
Vacuum	in	28
Sound pressure level	dB(A)	68
Handle vibration	m <sup>2</sup> / <sub>5</sub>	<2.5
Size (L x W x H)	in	35.4 x 15.75 x 43.3
Height (handle folded)	in	35.4 x 15.75 x 29.5
Weight – with batteries	lbs	167.6
Weight – without batteries	lbs	125.7
Weight – GVW	lbs	205
Warranty		1 year

- Noise levels measured at a distance of 10 inches from machine and 5 feet above floor, when scrubbing a hard floor. Measurements recorded using a hand held meter.
- Handle vibration does not exceed 2.5 m<sup>2</sup>/<sub>5</sub>, when operating on any surface with brush or pads.

Measurements recorded by an independent test laboratory

## 12. Accessories

Item	Part No.	Battery Scrubber
Standard brush (black)	PB414	General purpose scrubbing
Pad Driver	414DP	For use with pads
Squeegee front & rear blades PARA (1 pair of blades)	95.0048.00A	Wet pick up on all types of floor
Squeegee front & rear blades PARA (5 pair of blades)	95.0049.00	Wet pick up on all types of floor
Squeegee front & rear blades Anti-oil (1 pair of blades)	95.0050.00	Oil resistant squeegee blades
Squeegee front & rear blades Anti-oil (5 pair of blades)	95.0051.00	Oil resistant squeegee blades

**IMPORTANT:** Genuine accessories are only available from Powr-Flite authorized Service Agents or Powr-Flite Customer Services Department

### 13. Fault diagnosis

**WARNING - Before performing maintenance or making adjustments, switch off the machine and unplug from the electricity supply. In addition safely disconnect the non-grounded pole of the battery (or by equivalent method).**

The following simple checks may be performed by the operator.

Trouble	Reason	Battery Scrubber
The machine does not start up	Low battery Main fuse blown	Check that the battery is charged Replace the GREEN 30A main fuse
The brush does not rotate	Brush unit outlet overcurrent error or brush unit open circuit error Brush rotation button not pressed on handle controls	See paragraph 'Warning signals while using the machine (Section 5) Press the button
Vacuum does not work	Suction unit outlet over current error or vacuum unit circuit error Vacuum button not pressed on handle controls	See paragraph 'Warning signals while using the machine (Section 5) Press the button
The machine does not dry well, leaving traces of water	Vacuum off Vacuum tube blocked Squeegee rubbers not correctly set up Recovery tank full Squeegee rubber blades worn	Start the vacuum Check and if necessary clean the vacuum tube that connects the squeegee to the recovery tank Correct squeegee position Empty the recovery tank Replace or turn over the squeegee blades
No water comes out	Tank empty Solenoid valve button not pressed on handle controls Tap turned off Filter blocked Solenoid valve does not work	Fill the tank Press the button Turn on the tap located at the bottom of the machine Clean the filter Call Powr-Flite technical support
Insufficient floor cleaning	Unsuitable brushes or detergent Brush worn	Use brushes or detergents which are suitable for the type of floor or dirt to be cleaned Replace the brush

\* If the fuse blows several times, the machine should be checked by an authorised Service Agent

## WARRANTY

The manufacturer warrants to the original purchaser that products manufactured are free from defects, provided such goods are installed, operated and maintained in accordance with written manuals or other instructions for a period of 1 year from date of purchase on workmanship, motor, and parts. In case you, as our customer, meet any trouble with your machine, contact a Powr-Flite representative, who will be happy to be of service to you and will take care of any warranty issues. This warranty covers normal use and does not cover damage which occurs in shipment or failure resulting from alteration, accident, misuse, abuse, neglect or improper maintenance.

# ***Powr-Flite***<sup>®</sup>

A Tacony Company

3101 Wichita Court • Ft. Worth, TX 76140-1755

1-800-880-2913 • Fax: 1-817-551-0719 • [www.Powr-Flite.com](http://www.Powr-Flite.com)