

DUURA

www.DUURA.com
Sales@Duura.com • Techservice@Duura.com

Project Name: _____

Location: _____

Item #: _____ Qty: _____

Model: _____

SANDWICH STATIONS

Model: DVS27 DVS48 DVS60



DVS27



DVS48



DVS60

DUURA Sandwich Stations provide the perfect blend of durability and accessibility to allow for quick and easy preparation of sandwiches, salads and more at a value price. A high quality stainless steel exterior allows for easy cleaning and a heavy duty stainless steel insulated hood keeps products cool and fresh.

FEATURES

- Easy to grip recessed door handles
- 4 Casters (2 locking, 2 non-locking)
- Adjustable, heavy-duty wire shelves (1 per section/door)
- Available in multiple sizes to suit your needs
- Available in 120V/60Hz
- 11.42" deep cutting board is included on all models
- Comes with full set of clips on divider bars and 4" deep plastic pans

TEMPERATURE

- Holding temperature: 33° to 41°F (1° to 5°C)
- Utilizes environmentally friendly refrigerant R134A
- Forced-air refrigeration
- Efficient cooling system

CONSTRUCTION

- Exterior Material: Durable, easy to clean stainless steel
- Interior Material: Coated aluminum
- CFC Free Polyurethane insulated walls and doors
- Standard recessed door handles

REFRIGERANT

Environmentally-friendly R-134A propane

ELECTRIC

120/60Hz/1 Ph (NEMA 5-15)

Cord set includes plug & 9.8' (3m) cord

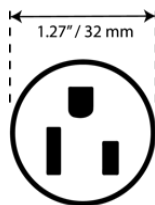

NEMA 5-15P



Certified to
ANSI-NSF 7



Certified to
ANSI UL 471

DUURA WARRANTY (USA / CANADA)

One (1) year parts/ labor

One (1) year compressor (part only)

Administered by DUURA

24/7 tech support provided

Due to periodic changes in designs, methods, procedures, policies and regulations, the specifications contained in this sheet are subject to change without notice. While we exercise good faith efforts to provide information that is accurate, we are not responsible for errors or omissions in information provided or conclusions reached as a result of using the specifications.

By using the information provided, the user assumes all risks in connection with such use.

The built in performance enhancing functions ensure that given proper attention and preventative maintenance, each DUURA Product will deliver years of trouble free, reliable, low maintenance, efficient operation.

4/25/2018

DUURA

www.DUURA.com
Sales@Duura.com • Techservice@Duura.com

Project Name: _____

Location: _____

Item #: _____ Qty: _____

Model: _____

SANDWICH STATIONS

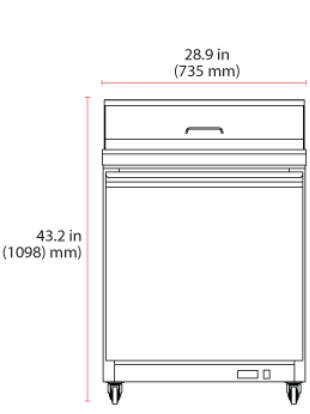

DVS27

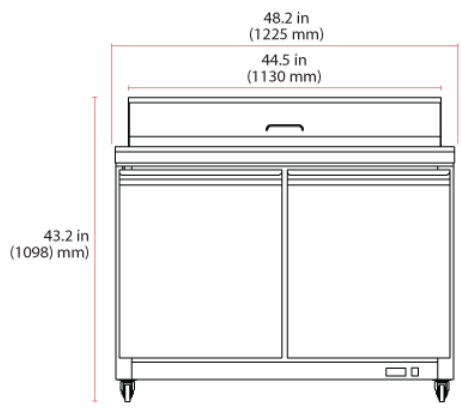

DVS48

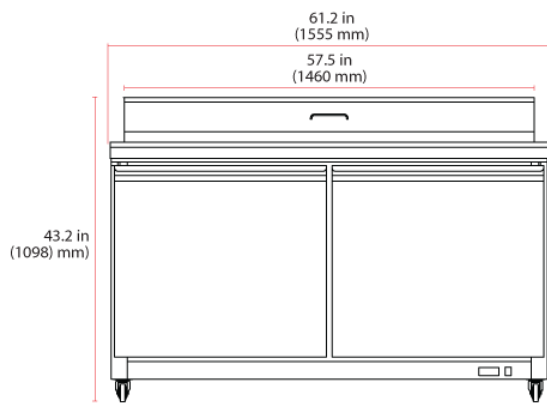

DVS60

	Dimensions in / mm	Capacity	Temperature Range	Voltage	Unit Weight	Doors	Pans (1/6)
DVS27	28.9 x 29.9 x 43.2 735 x 760 x 1098	7 Cu Ft 198 L	33°- 41° F 1°- 5° C	120V/60Hz	276 lb 125 kg	1	8
DVS48	48.2 x 29.9 x 43.2 1225 x 760 x 1098	12 Cu Ft 340 L	33°- 41° F 1°- 5° C	120V/60Hz	313 lb 142 kg	2	12
DVS60	61.2 x 29.9 x 43.2 1555 x 760 x 1098	15.5 Cu Ft 439 L	33°- 41° F 1°- 5° C	120V/60Hz	362 lb 164 kg	2	16

Due to periodic changes in designs, methods, procedures, policies and regulations, the specifications contained in this sheet are subject to change without notice.
While we exercise good faith efforts to provide information that is accurate, we are not responsible for errors or omissions in information provided or conclusions reached as a result of using the specifications.
By using the information provided, the user assumes all risks in connection with such use.