



www.DUURA.com
Sales@Duura.com • Techservice@Duura.com

Project Name: _____

Location: _____

Item #: _____ Qty: _____

Model: _____

SOLID DOOR REFRIGERATORS

INDOOR/OUTDOOR REFRIGERATION

Model: DR3



DR3

DUURA Indoor/Outdoor refrigeration is designed to fulfill your entertainment area needs. Perfect for any entertainment space, these units can be freestanding or built in and are designed to weather the elements when necessary while providing years of enjoyment with easy maintenance.

FEATURES

- Solid insulated stainless steel door enhances energy efficiency by preventing heat loss and minimizing condensation
- Interior long lasting and energy efficient LED lighting
- Field-reversible door
- 4 metallic wire shelves
- Comes with a 6' NEMA 5-15P cord set making the unit plug & play
- Approved for residential & commercial applications

TEMPERATURE

- Holding temperature: 35° to 40°F (1° to 5°C)
- Digitally controlled system maintains optimum temperature
- This unit is designed to store pre-chilled product at the ideal serving temperature – it is not intended to perform as a pull down refrigerator

CONSTRUCTION

- Exterior Material:
 - DR3: Black painted steel
- Stainless steel door with easy to grip handle running the length of the door
- Interior Material: ABS, an easy to clean, low maintenance surface
- Adjustable legs
- Polyurethane foam insulation to provide better thermal regulation and energy efficiency
- Comes with integrated condensate evaporator so no drain line connection is needed

REFRIGERANT

Environmentally friendly, CFC & HCFC free R-134A

ELECTRIC

120V/60Hz/1 Ph (NEMA 5-15P)
(220V/50 or 60Hz/1ph available as an option)
Circuit must be grounded & protected to 15 or 20 amps

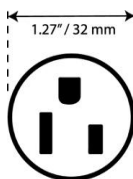

NEMA 5-15P



Intertek
Certified to
ANSI-NSF 7



Certified to
ANSI UL 471



For European
Market



DOE 2017
Compliant

DUURA WARRANTY (USA / CANADA)

One (1) year parts/labor
One (1) year compressor (part only)
Administered by DUURA
24/7 tech support provided

Due to periodic changes in designs, methods, procedures, policies and regulations, the specifications contained in this sheet are subject to change without notice. While we exercise good faith efforts to provide information that is accurate, we are not responsible for errors or omissions in information provided or conclusions reached as a result of using the specifications. By using the information provided, the user assumes all risks in connection with such use.

The built in performance enhancing functions ensure that given proper attention and preventative maintenance, each DUURA Product will deliver years of trouble free, reliable, low maintenance, efficient operation.



www.DUURA.com
Sales@Duura.com • Techservice@Duura.com

Project Name: _____
Location: _____
Item #: _____ Qty: _____
Model: _____

SOLID DOOR REFRIGERATORS

INDOOR/OUTDOOR REFRIGERATION

DR3

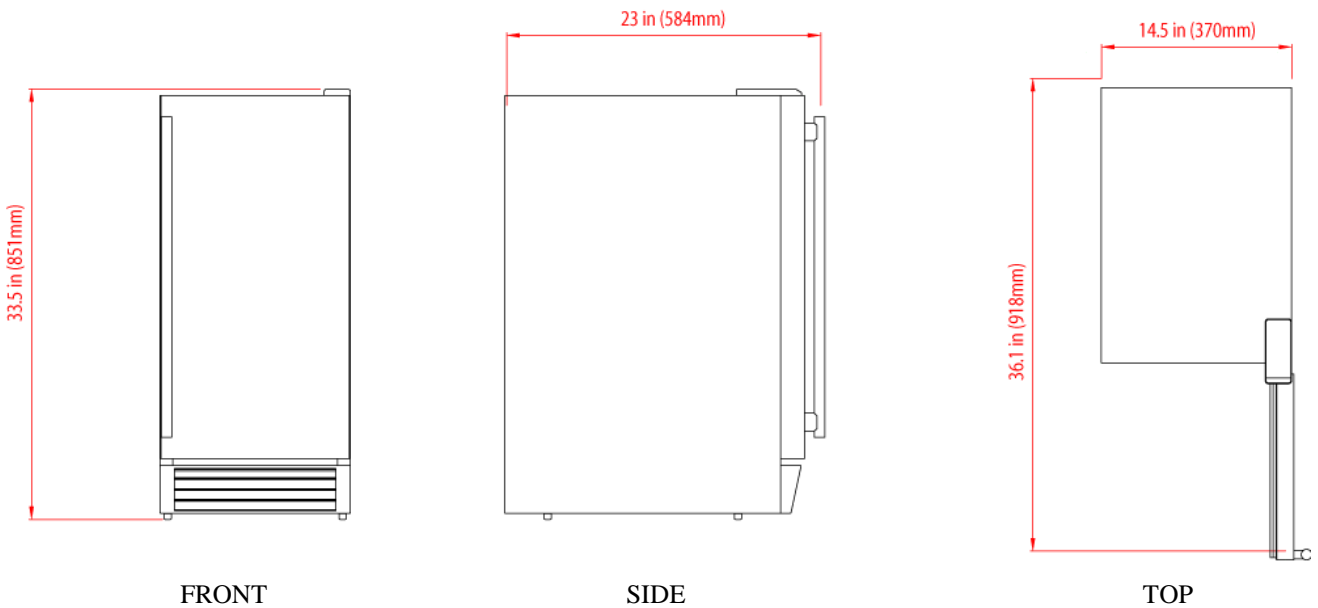

| Model | W x D x H (in) (mm) | Temperature Range | Watts | Amp Draw | Doors | Weight | Shelves |
|-------|-----------------------------------------|----------------------------|-------|----------|-------|----------------|---------|
| DR3 | 14.5 x 23 x 33.5in 368 x 584 x 851mm | 35° to 40° F 1° to 5° C | 400 | 4 | 1 | 77 lb 35 kg | 3 |

Due to periodic changes in designs, methods, procedures, policies and regulations, the specifications contained in this sheet are subject to change without notice.
While we exercise good faith efforts to provide information that is accurate, we are not responsible for errors or omissions in information provided or conclusions reached as a result of using the specifications.
By using the information provided, the user assumes all risks in connection with such use.