

DUURA

www.DUURA.com
Sales@Duura.com • Techservice@Duura.com

Project Name: _____

Location: _____

Item #: _____ Qty: _____

Model: _____

REACH-IN FREEZERS

Model: DLF1 DLF2



DLF1



DLF2

DUURA reach-in freezers are built to last. Temperature is digitally controlled and easily viewed from the exterior of the cabinet. Stainless steel construction ensures years of reliable service, maximum durability and is easy to clean. DUURA units are designed to meet the requirements of the most discriminating customer.

FEATURES

- Easy to grip recessed door handles
- Adjustable heavy duty wire shelves (3 per section/door)
- Four (4) or Six (6) 5" casters standard
- Open door alert, beeps when door has been open for three minutes
- Locking doors
- Automatic interior lighting
- Available in 120V/60Hz

TEMPERATURE

- Holding temperature: -10° to 10°F (-23° to 12°C)
- Utilizes environmentally friendly refrigerant R404A
- Digitally controlled temperature system maintains optimum temperature and LED display is easily viewed from exterior
- Large evaporator and condenser for quick cooling and greater efficiency
- Automatic defrost system

CONSTRUCTION

- Durable, easy to clean stainless steel exterior and interior
- Cord set includes plug & 9.8' (3m) cord
- CFC-free Polyurethane insulated walls and doors

REFRIGERANT

CFC & HCFC free R-404A

NEMA 5-15



ELECTRIC

DLF1/DLF2: 120/60Hz/1 Ph (NEMA 5-15)



Certified to
ANSI-NSF 7



Certified to
ANSI UL 471

DUURA WARRANTY (USA / CANADA)

One (1) year parts/labor
One (1) year compressor(part only)
Administered by DUURA
24/7 tech support provided

Due to periodic changes in designs, methods, procedures, policies and regulations, the specifications contained in this sheet are subject to change without notice. While we exercise good faith efforts to provide information that is accurate, we are not responsible for errors or omissions in information provided or conclusions reached as a result of using the specifications.

By using the information provided, the user assumes all risks in connection with such use.

The built in performance enhancing functions ensure that given proper attention and preventative maintenance, each DUURA Product will deliver years of trouble free, reliable, low maintenance, efficient operation.

4/25/2018 TLR

DUURA

www.DUURA.com
Sales@Duura.com • Techservice@Duura.com

Project Name: _____

Location: _____

Item #: _____ Qty: _____

Model: _____

REACH-IN FREEZERS

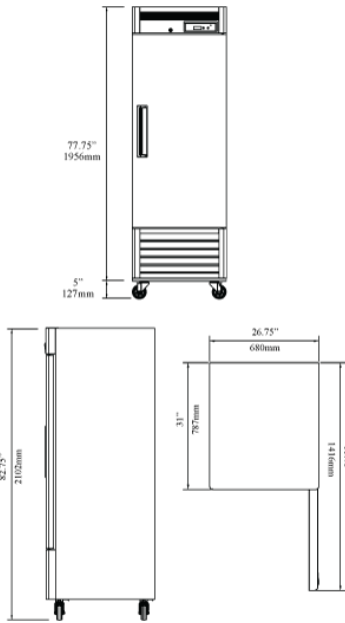

DLF1

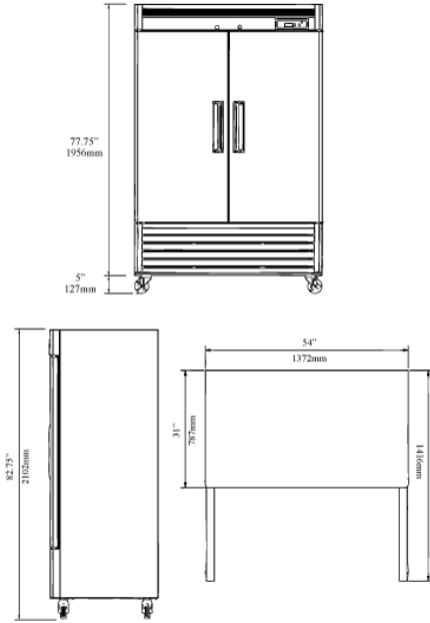

DLF2

*Shorter caster options are available to bring overall unit height under 80"

	Dimensions* in / mm	Capacity	Temperature Range	Voltage	Watts	Unit Weight	Shelves
DLF1	26.75 x 31 x 82.75 680 x 787 x 2102	23 Cu Ft 651 L	-10 - 10° F -23° - 12° C	120V/60Hz/1	805	284 lb 129 kg	3
DLF2	54 x 31 x 82.75 1370 x 787 x 2102	49 Cu Ft 1387 L	-10 - 10° F -23° - 12° C	120V/60Hz/1	1254	403 lb 183 kg	6

Due to periodic changes in designs, methods, procedures, policies and regulations, the specifications contained in this sheet are subject to change without notice.

While we exercise good faith efforts to provide information that is accurate, we are not responsible for errors or omissions in information provided or conclusions reached as a result of using the specifications.

By using the information provided, the user assumes all risks in connection with such use.