



www.DUURA.com
Sales@Duura.com • Techservice@Duura.com

Project Name: _____

Location: _____

Item #: _____ Qty: _____

Model: _____

SELF CONTAINED INDOOR/OUTDOOR ICE MAKER

Model: DI50-O



The compact DI50-O produces up to 65 pounds of ice per day (under ideal conditions) and includes a self-contained 25 pound storage bin. The unit produces crystal clear ice cubes and features a reversible stainless steel door. Suitable for freestanding or built in applications, this unit will run on standard household electrical current and is NSF and UL approved for commercial use.

ICE PRODUCTION

Air Temp 70°F (21°C) Water Temp 50°F (10°C)
Daily Ice Production: 65 lbs (23kg)
Energy Consumption 10.1kWh/100lb of ice produced
Water Usage 13.8 gal./100lb of ice produced

Air Temp 90°F (32°C) Water Temp 70°F (21°C)
Daily Ice Production: 51 lbs (31kg)

Storage Bin holds 25lbs of ice with automatic overflow prevention
Gravity Drain connection is required, along with a water supply line.

OPERATING REQUIREMENTS

Ambient Temperature Range 50° to 99°F (10° to 37°C)
Water Temperature Range 40° to 90°F (4° to 32°C)
Water Supply Line Connection 1/4" O.D. Compression
Water Pressure Range
Min PSI 15 Max PSI 75 (above 75 requires a regulator)
Min Bar 1.0 Max Bar 5.5

FEATURES and CONSTRUCTION

- Exterior Material: Stainless Steel
- Air Cooled Compressor
- Adjustable, sturdy plastic legs
- Built-In Self Cleaning Mode for use with nickel safe cleaning solution
- Includes: Scoop

Tubeing for Supply and Drain Lines
NEMA 5-15 cord set for simple installation

* A Water filter is recommended for a more efficient operation with less required maintenance and cleaning.

* 3rd Party Approvals: ANSI NSF 12, ANSI UL 563 & DOE2017

REFRIGERANT

- CFC & HCFC free R-134A

ELECTRIC

120V/60Hz/1 Ph (NEMA 5-15P)



Certified to
ANSI-NSF 12



Certified to
ANSI UL 563



DUURA WARRANTY (USA / CANADA)

One (1) year parts/labor
One (1) year compressor (part only)
Administered by DUURA
24/7 tech support provided

Due to periodic changes in designs, methods, procedures, policies and regulations, the specifications contained in this sheet are subject to change without notice. While we exercise good faith efforts to provide information that is accurate, we are not responsible for errors or omissions in information provided or conclusions reached as a result of using the specifications.

By using the information provided, the user assumes all risks in connection with such use.

The built in performance enhancing functions ensure that given proper attention and preventative maintenance, each DUURA Product will deliver years of trouble free, reliable, low maintenance, efficient operation.

DUURA

www.DUURA.com
Sales@Duura.com • Techservice@Duura.com

Project Name: _____

Location: _____

Item #: _____ Qty: _____

Model: _____

SELF CONTAINED INDOOR/OUTDOOR ICE MAKER

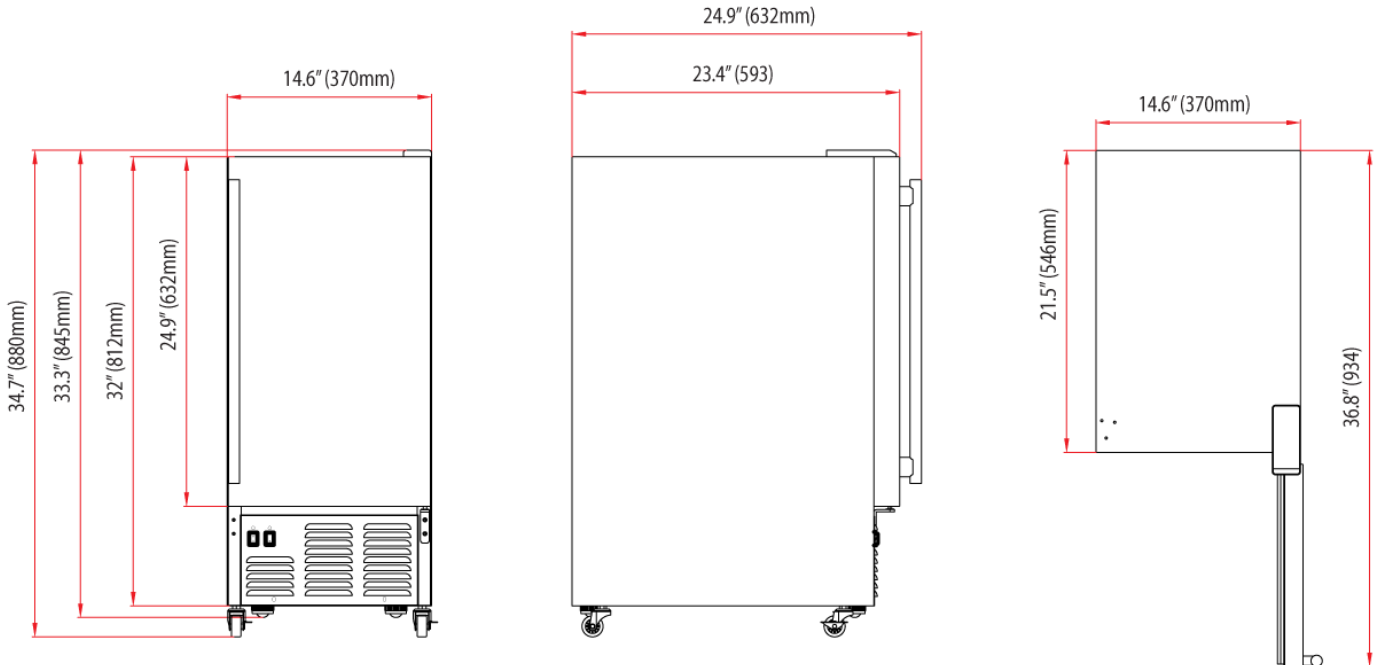

DI50-O	
In: External Dimensions W x D X H	14.6 x 25 x 34.7
mm: External Dimensions W x D X H	370 x 632 x 880
Average Amp Draw	1.9
Unit Weight	83 lb / 37 kg
Shipping Weight	93 lb / 42 kg
Production based on ambient conditions	
50°F Water / 70°F Air	Up to 65 lbs of ice/day
70°F Water / 90°F Air	Up to 51 lbs of ice/day
Ice Cube Produced (Dimensions)	Clear Slab Cube (3/4 x 3/4 x 1" / 19 x 19 x 25mm)

Due to periodic changes in designs, methods, procedures, policies and regulations, the specifications contained in this sheet are subject to change without notice.

While we exercise good faith efforts to provide information that is accurate, we are not responsible for errors or omissions in information provided or conclusions reached as a result of using the specifications.

By using the information provided, the user assumes all risks in connection with such use.