

DUURA

www.DUURA.com
Sales@Duura.com • Techservice@Duura.com

Project Name: _____

Location: _____

Item #: _____ Qty: _____

Model: _____

GLASS DOOR MERCHANDISER | 16 Cu Ft REFRIGERATOR

Model: DGMW16R



DGMW16R

Glass Door merchandisers are designed for durability and visual appeal in promoting your product. Glass door merchandisers are energy efficient and effective at keeping product at exactly the right temperature. This keeps food fresher for longer. The simple-to-use but precise digital controls allows for accuracy in temperature and flexible use of the unit.

FEATURES

- Hinged Door Models: Self-closing, magnetic gasket
- Double pane heated glass glass doors enhance energy efficiency by preventing heat loss and minimizing condensation
- Interior LED lighting
- Bottom mounted oversized compressor
- (3) shelves. Heavy-duty, PE (polyethylene) coated wire shelves
- Pre-programmed automatic defrost cycle for ideal, trouble-free storage conditions
- Temperature reading visible from up to 15 feet away
- Door lock
- Adjustable feet for uneven flooring

TEMPERATURE

- Holding temperature: 32° to 40°F (0° to 4°C)
- Digitally controlled system maintains optimum temperature

CONSTRUCTION

- Exterior Material: Powder coated steel.
- Interior Material: Powder coated aluminium. Easy to clean, low maintenance.

REFRIGERANT

- CFC & HCFC free R-404A

ELECTRIC

Single Door: 115/60Hz/1 Ph (NEMA 5-15)



DUURA WARRANTY (USA / CANADA)

One (1) year parts/labor
One (1) year compressor (part only)
Administered by DUURA
24/7 tech support provided

Due to periodic changes in designs, methods, procedures, policies and regulations, the specifications contained in this sheet are subject to change without notice. While we exercise good faith efforts to provide information that is accurate, we are not responsible for errors or omissions in information provided or conclusions reached as a result of using the specifications. By using the information provided, the user assumes all risks in connection with such use.

The built in performance enhancing functions ensure that given proper attention and preventative maintenance, each DUURA Product will deliver years of trouble free, reliable, low maintenance, efficient operation.

DUURA

www.DUURA.com
Sales@Duura.com • Techservice@Duura.com

Project Name: _____

Location: _____

Item #: _____ Qty: _____

Model: _____

GLASS DOOR MERCHANDISER | 16 Cu Ft REFRIGERATOR

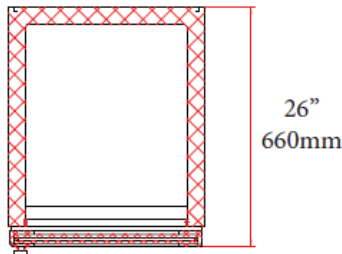
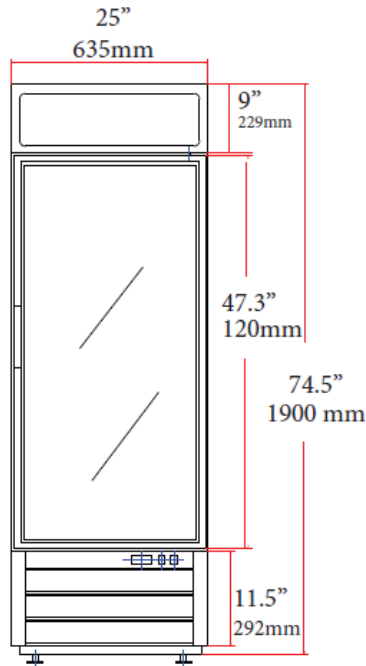

	DGMW16R
In: External Dimensions W x D X H	25 x 26 x 75
mm: External Dimensions W x D X H	635 x 660 x 1900
Nominal Capacity	16 Cu Ft / 453 L
Doors	1
Shelves	(3) shelves
Amps (Watts)	11 Amps
Unit Weight	243 lb / 110 kg

Due to periodic changes in designs, methods, procedures, policies and regulations, the specifications contained in this sheet are subject to change without notice.

While we exercise good faith efforts to provide information that is accurate, we are not responsible for errors or omissions in information provided or conclusions reached as a result of using the specifications.

By using the information provided, the user assumes all risks in connection with such use.