



TEST OUR METAL®

All Welded Mobile Rack

For 12" X 20" Pans and 18" X 26"
and 14" X 18" Trays

- All Welded Aluminum Construction with 1" Square 6063-T5 aluminum alloy tubing with a wall thickness of .065".
- Welded reinforcement rods between side frames for added strength and rigidity.
- One Piece Side Frames for added strength and durability.
- Rolled corners on side frames for easy installation of rack covers.
- Extruded 1/8" thick 6063 T-5 Aluminum Alloy Versatile Tray Slides with raised bearing surface for ease in loading and unloading pans.
- 2 1/8", 3 1/8" or 5" Slide spacing available.
- All Welded 6063-T5 Solid Aluminum .100" thick bottom with .100" thick aluminum welded hat channels for casters and a perimeter non-marking bumper.
- 5" plate type casters, two rigid and two swivel with brakes.
- Lifetime warranty, excluding casters.

Job: _____

Item No. _____

Models

- ORV-3-1809-X
- ORV-5-1811-X
- ORV-3-1818-X



ORV-3-1818-X shown
with optional perimeter bumper



Made in USA

451 E. County Line Rd. • P.O. Box 1089 • Mooresville, IN 46158
Toll Free 800-733-8073 • Local 317-831-7030 • Fax 317-831-7036
www.secoselect.com

MODEL #	TRAY CAPACITY		PAN CAPACITY 12" X 20"	HEIGHT DIM A	WIDTH DIM B	DEPTH DIM C	SHIPPING CUBE FEET	SHIP WEIGHT
	18" X 26"	18" X 14"						
ORV-3-1809-X	9	18	8	36 1/2"	20 5/8"	26 1/4"	18	45
ORV-3-1818-X	18	36	17	64 1/2"	20 5/8"	26 1/4"	23	65
ORV-5-1811-X	11	22	10	64 1/2"	20 5/8"	26 1/4"	20	65

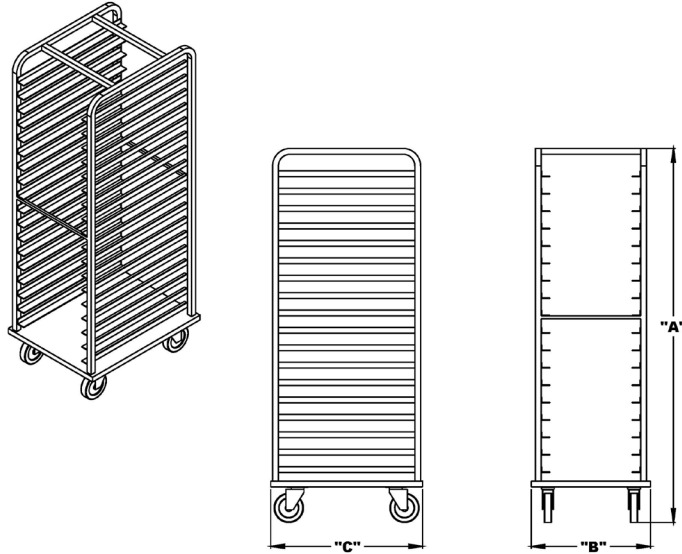

GENERAL: Rack shall be all aluminum construction and shall be fully welded.

BASE: Base shall be .100 Aluminum and shall be reinforced with .100 aluminum hat-channels. Casters through bolt base and hat-channels.

POST: Posts shall be constructed using 1" square tubing of 6063 – T1 alloy. This alloy shall have a wall thickness of .065". Two 3/4" reinforcement rods are welded between the posts for rigidity. Each post is arched for maximum strength.

SLIDES: Slides shall be constructed using .100" thick aluminum with a raised bead. Slides are welded to rack posts.

CASTERS: Rack shall come complete with 4-5" non-marking plate casters, 2 rigid and 2 swivel. Casters shall have a weight capacity of 200 lbs each.

Accessories, Options, Variations

- Vertical Corner Bumpers
- Premium Non Marking Rubber Tires
- Standard Pan Top
- Optional perimeter bumper guard

We reserve the right to change specifications and product design without notice. Such revisions do not entitle the buyer to corresponding changes, improvements, additions or replacement for previously purchased equipment.



TEST OUR METAL®

451 E. County Line Rd. • P.O. Box 1089 • Mooresville, IN 46158
 800-733-8073 • Local 317-831-7030 • Fax 317-831-7036
www.secoselect.com

REV 2016-11