



## DESIGNED FOR HEALTHY SMOOTHIES

Three – 12 oz. Servings per Minute

GREAT FOR RESTAURANTS, SCHOOLS AND  
HEALTH CARE

The **SaniServ**® model 608S Smoothie Freezer provides consistent quality yogurt and fruit. Smoothie or a yogurt Smoothie base. Rapid dispensing of ready to serve healthy and nutritious smoothies is at your finger tips. Use a Yogurt base and ingredients to create flavors your customers will crave.

### EASY CLEANING AND OPERATION

**Fewer Parts = Simplified Cleaning** – **SaniServ**® equipment is designed and built with the fewest parts to be disassembled, cleaned and sanitized than any other machine in the industry. The state of the art solid-state **AccuFreeze**® control insures product consistency, worry-free operation and customer satisfaction.

### HIGH RETURN ON INVESTMENT

**Increased Profits** – **SaniServ**® machines combine efficiency with consistent product quality and fast, quiet operation while insuring customer satisfaction with high profit and nutritious smoothie products.

### QUALITY DESIGN

**Durability** – **SaniServ**® machines are built to achieve long and dependable life through simplicity of design. Every machine is shipped standard with a stainless steel exterior, durable steel interior frame construction, heavy-duty components and consistency systems.

We reserve the right to change specifications and product designs without notice. Such revisions do not entitle the buyer to corresponding changes, improvements, additions or replacements for previously purchased equipment.



Made in USA



## Model 608S

Countertop

**Smoothie Machine**

With **AccuFreeze**® Control



**Fresh Beverages**

423 Boulevard

Passaic, NJ 07055

Tel: 973.767.1070

Fax: 973.510.2443

[www.freshbeverages.com](http://www.freshbeverages.com)

# MODEL 608S

## Counter Model Smoothie/Yogurt Base Freezer

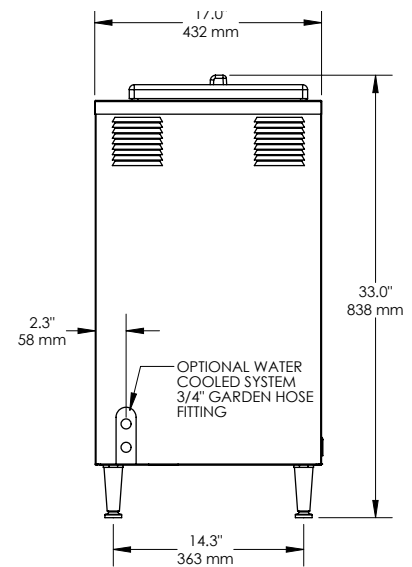
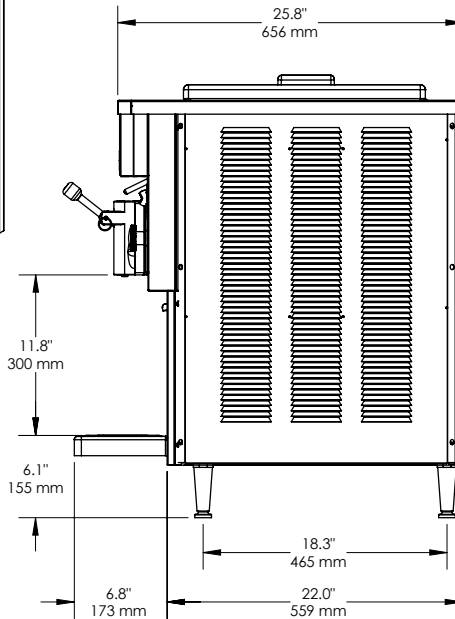
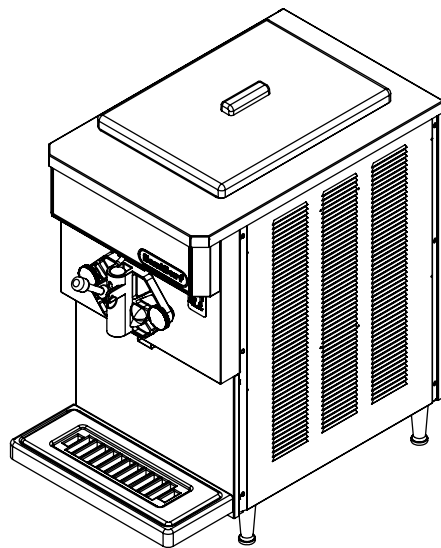

Minimum Wall Clearance  
Both Sides and Back -  
6 inches (152 mm)

ELECTRICAL				WIDTH	HEIGHT	DEPTH	WEIGHT	VOLUME
VOLTS	Hz	Ph.	Amps	INCHES (MM)	INCHES (MM)	INCHES (MM)	LBS. (Kg)	CU FT. (cu. m.)
120 V	60	1	15	17 (432)	33.0 (838)	24.8 (630)	208 (95)	
Shipping Specifications				22.5 (572)	41 (1042)	34.5 (876)	265 (120)	18.5 (.53)

### Specifications:

**Cooling System:**  
Air or Water

**Dasher and Compressor Motors:**  
1 HP Dasher  
1 HP Compressor

**Refrigerant Type:**  
R404A

**Listings:**  
UL, cUL, NSF

### Features:

**Evaporator and Mix Reservoir Capacity:**  
20 Quarts (18.9 liters)

**Dasher:**  
Heavy-Duty Stainless Steel with low friction scraper blades.

**Controls:**  
**AccuFreeze®** solid-state control for accurate product consistency.

**Solid State Audio/Visual Mix Out System with Compressor Lockout**

### Warranty:

Parts 1 year  
Compressor 5 years  
Evaporator 5 years

### Options:

Tune Up Kit  
Parts Tray  
Syrup Rail  
Counter Top Mounting Pad  
Machine Stand  
Water Cooled - 3/4" Garden Hose Fitting  
Wash Out Kit - 3/8" Flare Fitting

### Fresh Beverages

423 Boulevard  
Passaic, NJ 07055  
Tel: 973.767.1070  
Fax: 973.510.2443  
www.freshbeverages.com