

GIMBLE LOCK PLATE DETAIL
1:2

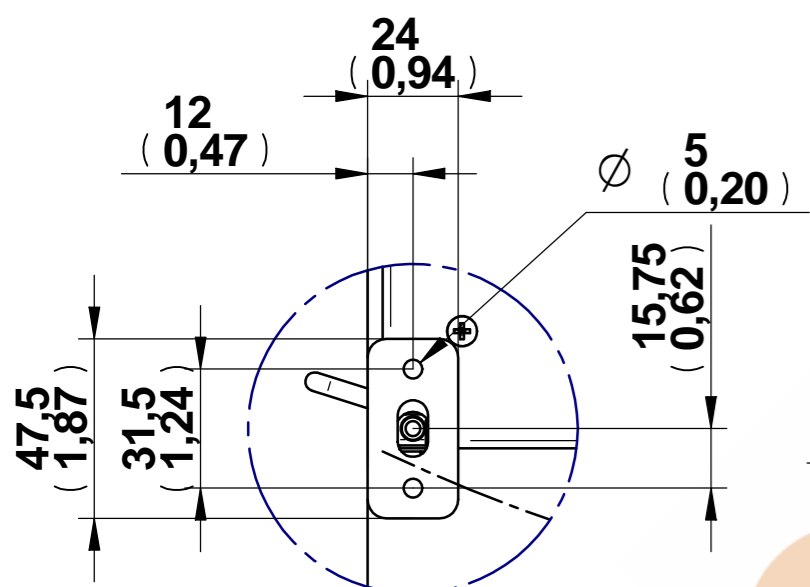

GIMBLE PLATE DETAIL
1:2

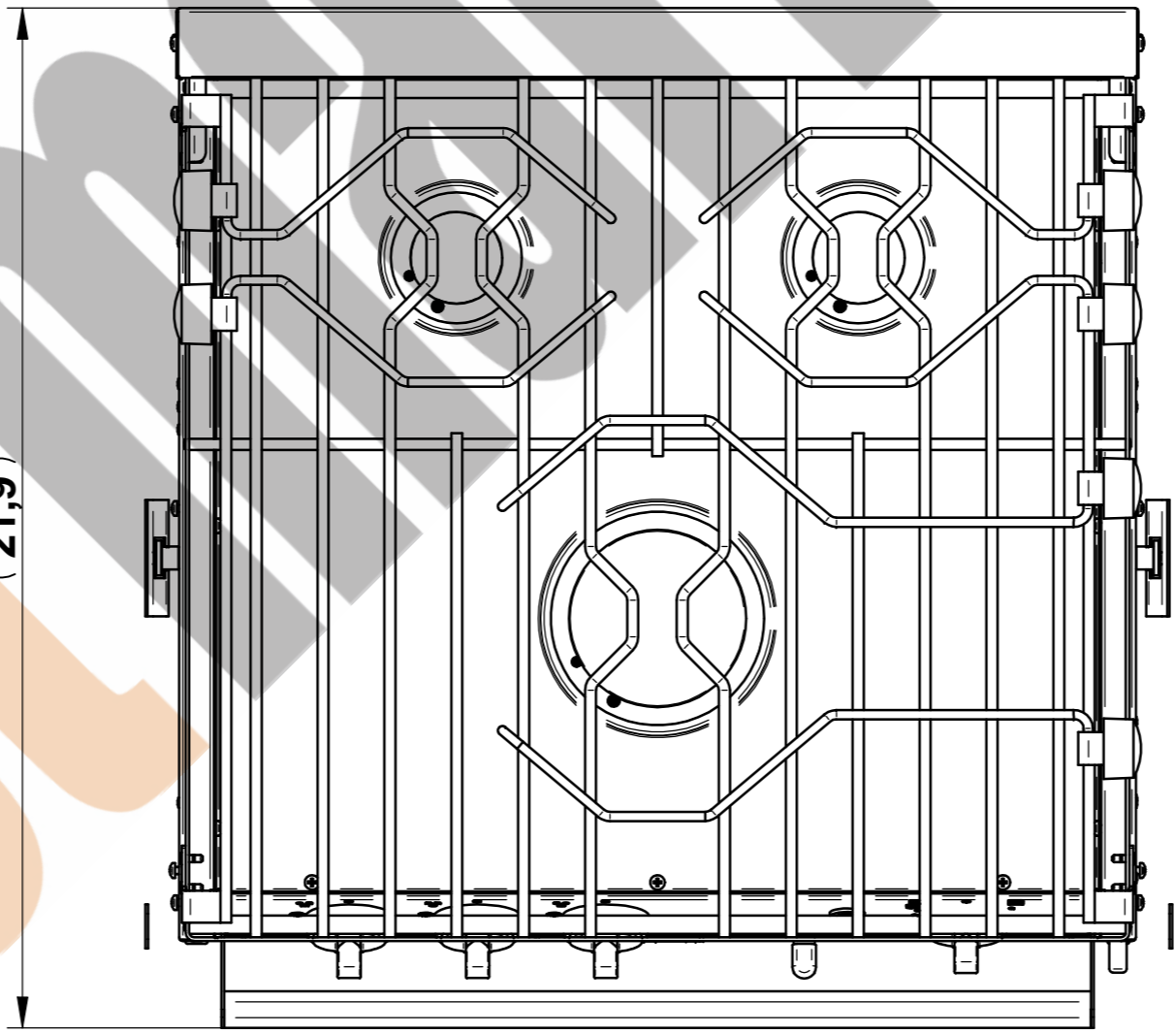
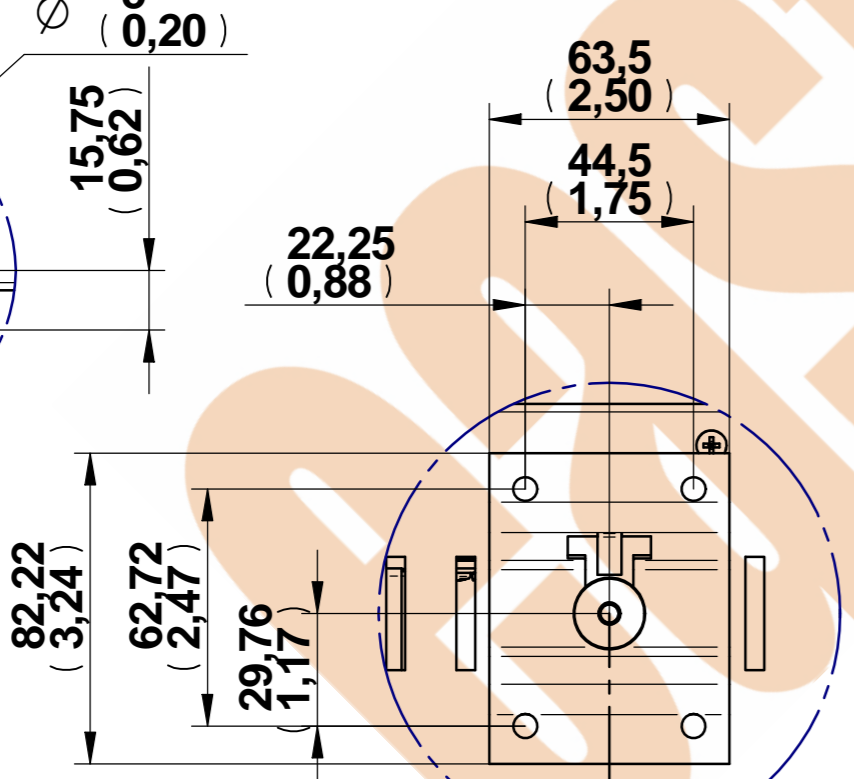

		mm	Inches
A		559	22
B	Gimble $\pm 15^\circ$	540	21 1/4
	Bascule $\pm 15^\circ$		
B	Gimble $\pm 30^\circ$	578	22 3/4
	Bascule $\pm 30^\circ$		
C		603	23 3/4
D		56	2,20
E		65,5	2,60
F		540	21 1/4
G		181,5	7,15
H		213	8,40

Les dimensions sont en : mm
Dimensions are in : (inches)

Surface:	Trait. de Surface:	Masse: 0,000 kg
Ce document est la propriété exclusive de la société ENO. Toute communication, divulgation ou reproduction, même partielle doit faire l'objet d'une autorisation écrite de son propriétaire.		
Dessiné par: FG	le 16/05/2011	ECHELLE :
Vérifié par:	le	Format: A3
R-FOUR 3 FEUX NA STD 3 BURNER NA STD STOVE		95, rue de la terraudière B.P. 8532 79025 NIORT Cedex 09
Dernière Modif. le 07/06/2011		Pages 1 / 1
		F63351