

ebios  fire[®]
burning passion

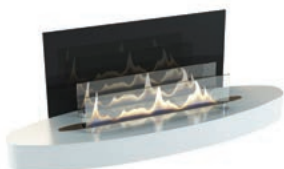

PRODUCT OVERVIEW

FREE STANDING UNITS THE DESIGN COLLECTION



ELIPSE WALL

Pages 12/13



ELIPSE WALL MINI

Pages 12/13

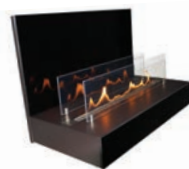

QUADRA WALL

Page 14



CAMBRIDGE 600

Page 16



OXFORD 600

Pages 18/19



OXFORD 700

Pages 18/19



ELIPSE BASE

Pages 22/23



ELIPSE BASE MINI

Pages 22/23



QUADRA BASE

Page 24

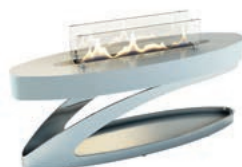

ELIPSE Z

Page 26



NANO

Page 30



PASSO E

Page 32



LIBERTY

Page 35



AVIATOR

Page 37



STEEL

Page 38



TOWER

Page 42



ARCHITECTURE SL

Page 44



LA VELA MIDI

Pages 46/47



LA VELA GRANDE

Pages 46/47

BUILT-IN FIREPLACES: THE ARCHITECTS COLLECTION

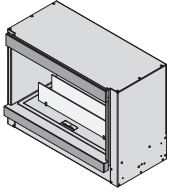

1V FRONT
Pages 56/57

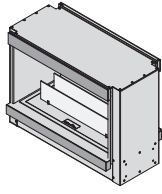

FD TUNNEL
Pages 56/57

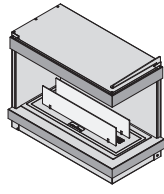

2R 2-SIDED
Pages 56/57

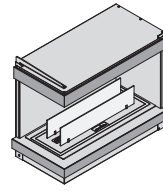

2L 2-SIDED
Pages 56/57

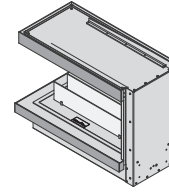

U 3-SIDED
Pages 56/57

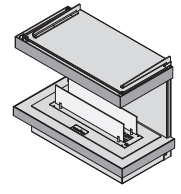

C 3-SIDED
Pages 56/57



THE CITY
Page 58



CABINET FIRE
Page 60



KENSINGTON
Page 66

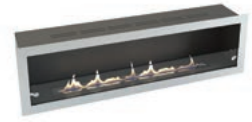

CHELSEA
Page 70

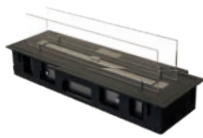

QUADRA INSIDE I SL
Pages 72/73



QUADRA INSIDE II SL
Pages 72/73



QUADRA INSIDE III SL
Pages 72/73

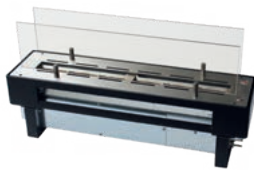

QUADRA INSIDE AUTOMATIC I SL
Pages 74/75



QUADRA INSIDE AUTOMATIC II SL
Pages 74/75

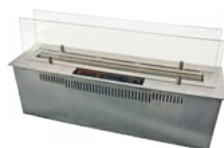

EBIOS ONE 500/500 PLUS
Pages 76/77

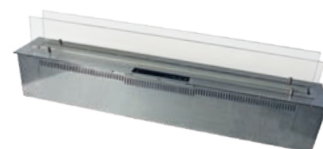

EBIOS ONE 1000
Pages 78/79

COMPANY



SPARTHHERM – THE FIRE COMPANY

Since its foundation in 1986, the name SPARTHHERM Feuerungstechnik GmbH has come to represent innovation and high-quality in fireplace inserts, free standing stoves as well as gas and bioethanol fires.

In two plants equipped with state-of-the-art machinery,

our 1,000 employees design, develop and manufacture over 50,000 appliances per year, which impress even the most discerning customer with their safety, quality, function and design.



ebios-fire® – OUR EXCLUSIVE RANGE OF BIOETHANOL FIREPLACES

In private residences, in low-energy and passive houses, in luxury apartments and garden conservatories – **our ebios-fire®** bioethanol fireplaces are right at home in any place where style, atmosphere and flair are valued, as they require neither a chimney nor a flue. With a wide selection of product designs including floor, table top and wall-mounted models as well as customised built-in fireplaces, **ebios-fire®** bioethanol fireplaces combine maximum safety with high quality and a unique style. They make it easy to create a blazing focal point for any living space.

In close cooperation with architects and interior

designers, the **ebios-fire®** experts at SPARTHERM create custom-made bioethanol fireplace solutions for luxury developments, private residences, regal palaces, offices, hotels and spa resorts. **ebios-fire®** appliances are sold through an extensive, independent network of fireplace specialists, design and lifestyle stores in an ever-increasing number of countries.

QUALITY IS OUR TRADITION – NOW AND IN THE FUTURE

We are proud to be a highly successful family-run business, driven by our dedication to highest quality and product safety, which is paired with our passion for exclusive and functional design. With expertise and dedication our **ebios-fire®** expert team creates magical moments around mesmerising flames for our customers. We share a burning passion for fire with our business

partners and customers, who reward us with loyalty and satisfaction for the excellent customer service we offer every day.



BIOETHANOL

Practically odour-free

No chimney

No ash

THE GREEN ALTERNATIVE

ebios-fire® fireplaces can only be used with bioethanol. Bioethanol, a renewable fuel generated through fermentation of sugar and starch components of plant by-products – primarily sugar cane, potatoes, grains and hay – has a neutral environmental footprint.

In addition to heat, burning bioethanol only generates water vapour and carbon dioxide (CO₂), making **ebios-fire**® fireplaces practically odour-free. This makes a chimney or flue completely unnecessary. Our Passo E model is the only exception.

As an alcohol-based liquid, bioethanol begins to evaporate at around 12°C. The vapours generated from this process are heavier than air and therefore remain on top of the surface of the liquid bioethanol. It is therefore only the ethanol gas, not the liquid ethanol, which burns when lit.

As a renewable energy source, bioethanol is used for a wide variety of purposes nowadays: When blended with petrol, it makes transport fuel more sustainable; it is used in production processes of the medical, cosmetics and food industry. And – last but not least – it creates a beautiful, lively flame with practically no odour or residue when used in **ebios-fire**® appliances.



CLEAN COMBUSTION AND NEUTRAL FOOTPRINT

Bioethanol consists entirely of biological matter. Its great advantage is a neutral environmental footprint. The CO₂ generated during combustion is absorbed by plants, which process it via

photosynthesis for their own growth. This cycle of creation and combustion of energy – in a way “recycling of energy” – makes bioethanol a carbon₂-neutral fuel.

GREAT POWER THANKS TO LOW CONSUMPTION

All **ebios-fire**[®] appliances are designed to ensure low fuel consumption, provided the combustion temperature is ideal.

STORAGE AND HANDLING

Bioethanol is a Class 1B Flammable Liquid (flammability) and rated Class 3 PGII (transport) and is therefore regulated by various standards around the world.

Please familiarise yourself with these safety standards in order to guarantee safe storage and handling of this fuel in accordance with all valid regulations.



Bioethanol for **ebios-fire**[®] appliances

ebios-fire[®] burners may only be operated with bioethanol of at least 96.6 % but max. 97.0 % purity. We recommend a purity level of 96.6 %.

CONSUMPTION

For information on the fuel consumption of **ebios-fire**[®] appliances, refer to the corresponding product specifications.





THE COLOUR OF THE YEAR

is PANTONE 16-1546 Living Coral. It evokes warmth and cosiness, comfort and vitality in our dynamic environment.

This cheerful coral red is a lively yet, thanks to its golden undertone, cosy colour. Whether you use it to enliven your walls or as a colour for your pleated blinds to create a beautiful orange ambience when the light shines through: Living Coral creates a joyful atmosphere that leaves nobody unmoved.

JAB PLEATED BLINDS IN CORAL RED

JAB ANSTOETZ Systems provides unique sun protection solutions which satisfy even the most discerning customers' requirements for design, individuality and function. These pleated blinds in the trend colour "Living Coral" are the perfect example. Customers love pleated blinds above all other sun protection solutions.

As a product with many qualities, they are the perfect screen to protect you from sunlight and glare. At the same time, this modern version of a traditional curtain is a stylish feature for any room, as it fits seamlessly into any and all environments. Sophisticated engineering and fine materials as well as a vast selection of designs ensure that this product range offers something for any taste. **Photo: www.jab.de**

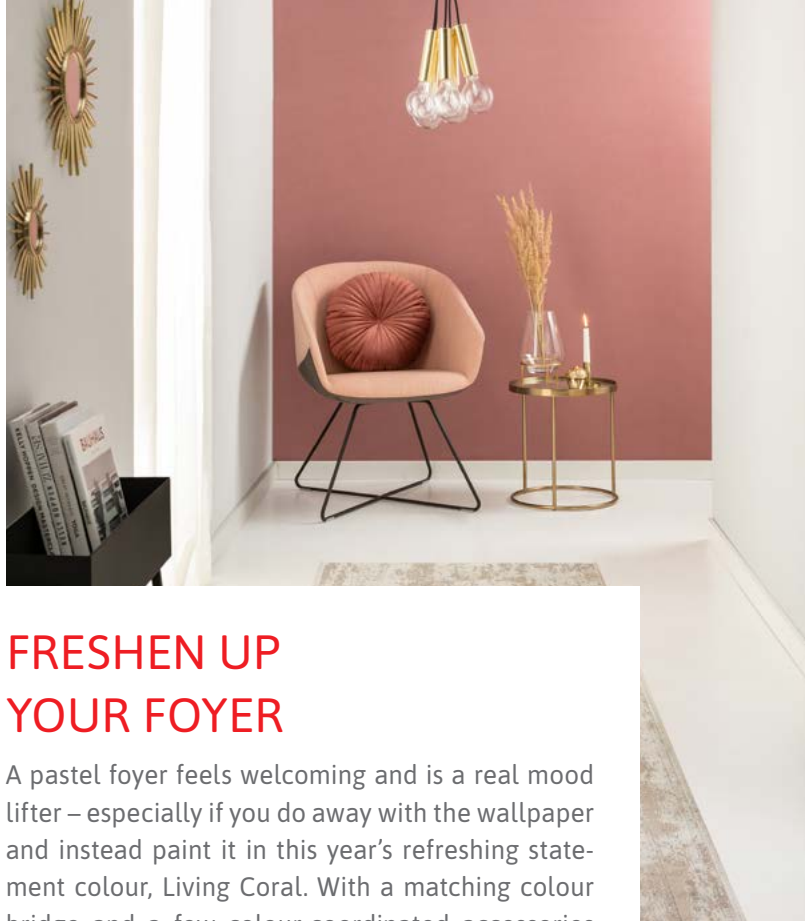

FRESHEN UP YOUR FOYER

A pastel foyer feels welcoming and is a real mood lifter – especially if you do away with the wallpaper and instead paint it in this year's refreshing statement colour, Living Coral. With a matching colour bridge and a few colour-coordinated accessories for good measure you can show that your space is at the height of fashion.

Photo: www.benuta.de

CHAIR "ALBA" BY TON

An impressive design, precise workmanship, upholstery with integrated pocket springs and the perfect ergonomic properties – just a single glance will tell you that Alba with its harmony of shapes promises unique comfort. It looks great as a stand-alone piece and favourite chair or in a lounge suite, encouraging anyone who passes by to sit down, relax and enjoy.

Photo: www.ton.eu



FREE STANDING UNITS THE DESIGN COLL

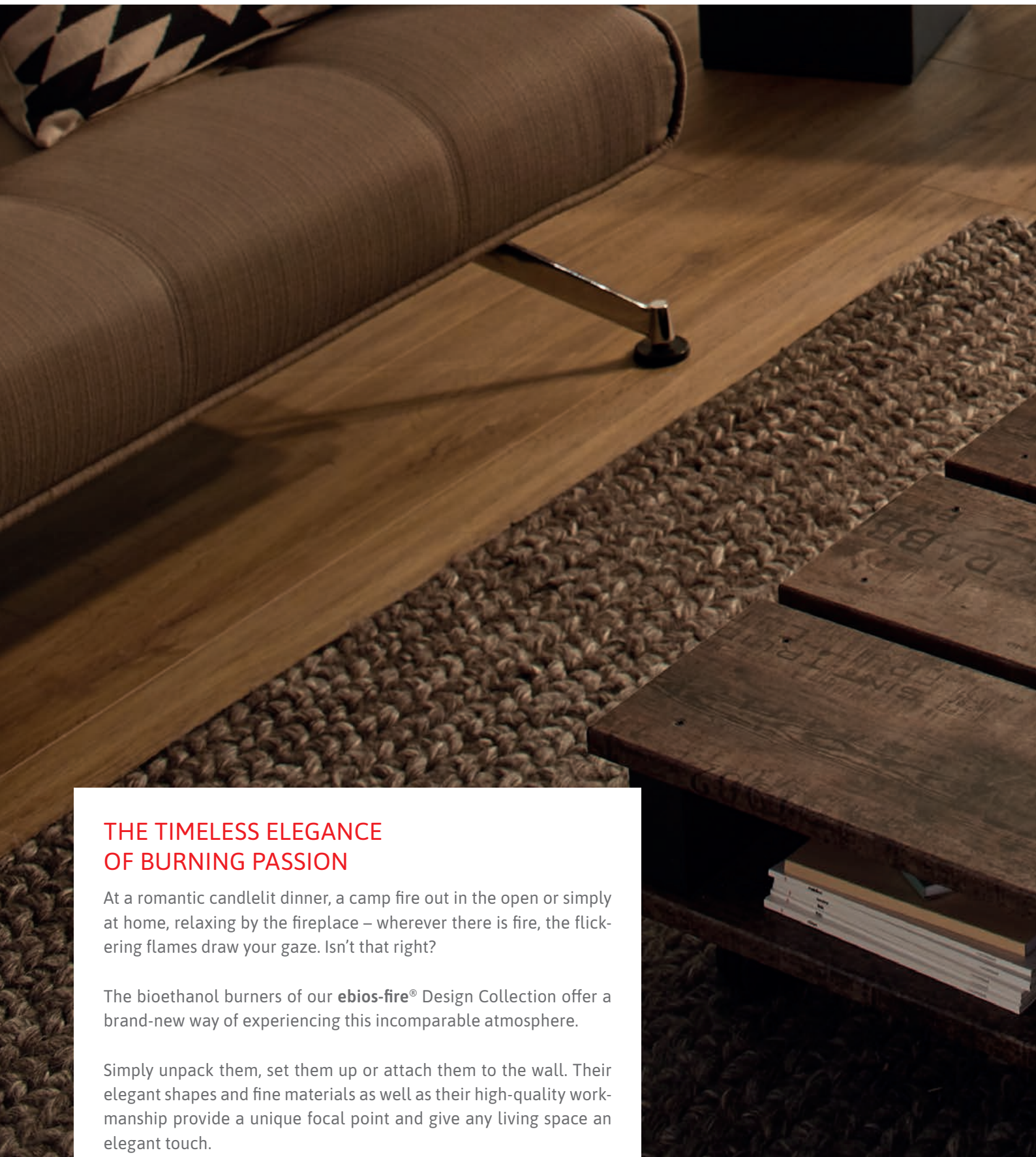

THE TIMELESS ELEGANCE OF BURNING PASSION

At a romantic candlelit dinner, a camp fire out in the open or simply at home, relaxing by the fireplace – wherever there is fire, the flickering flames draw your gaze. Isn't that right?

The bioethanol burners of our **ebios-fire®** Design Collection offer a brand-new way of experiencing this incomparable atmosphere.

Simply unpack them, set them up or attach them to the wall. Their elegant shapes and fine materials as well as their high-quality workmanship provide a unique focal point and give any living space an elegant touch.

SECTION



ELIPSE WALL | ELIPSE WALL MINI

GEOMETRY OF DANCING FLAMES



ebios-fire® Elipse Wall

The **ebios-fire®** Elipse Wall (left) is a geometric marvel: It is both round and rectangular at the same time, with different materials, shapes and colours harmonising with the fire.







ebios-fire® Elipse Wall Mini

Thanks to its compact size, the **ebios-fire®** Elipse Wall Mini (top) fits perfectly into any room, bringing a beautiful fire to life.

The flames dance on the oval housing between two fire-proof glass panels. This fascinating dance is reflected on the glossy black of the rear glass panel by the reflective panes, creating a sea of flame.



CLADDING FINISH

-  Matt black
-  Matt white
-  Stainless steel, brushed
-  Chrome

REAR GLASS PANEL FINISH

-  Black

Technical details, see page 84



QUADRA WALL CONTEMPORARY ART ON FIRE

The Quadra Wall is a highlight of style and class. Its clear lines contrast with the alluring flicker of the flames and are sure to create a unique ambiance – even on dull rainy days and long, dark winter nights.



BURNER CASE FINISH



Matt black



Stainless steel,
brushed

GLASS CERAMIC FINISH



Black

Technical details, see page 84

CAMBRIDGE 600

LIKE A MESMERISING PAINTING

A stylish wall-mounted bioethanol fireplace like the Cambridge 600 can liven up any room, even those without a chimney. This **ebios-fire®** model captivates with high-quality materials and a discreet minimalist design: The burner made of brushed stainless steel practically

floats in front of the black rear panel – and is framed by a safety glass front panel supported by four solid mounts. This fireplace, designed to be mounted flush with the wall, provides the perfect stage for mesmerising flames anywhere from living rooms to conservatories. Even in



offices, bars and restaurants, this model will create an atmosphere sure to ignite the spark of enthusiasm. In a nutshell: The Cambridge 600 creates an atmosphere beyond compare.



BURNER FINISH

 Stainless steel,
brushed

REAR PANEL FINISH

 Nero

Technical details, see page 85

OXFORD 600 | OXFORD 700

WALL-MOUNTED FIREPLACES FOR SOPHISTICATED TASTES

The **ebios-fire®** Oxford 600 fireplace features an extra-wide frame, available in high-gloss white, timeless black, brushed stainless steel or chrome, and a half-height transparent pane made of glass ceramics with a matt black rear panel behind it. This model is available as a

wall-mounted or integrated design.

The fascinating effect of the flames flickering in this fireplace make it a true design highlight.

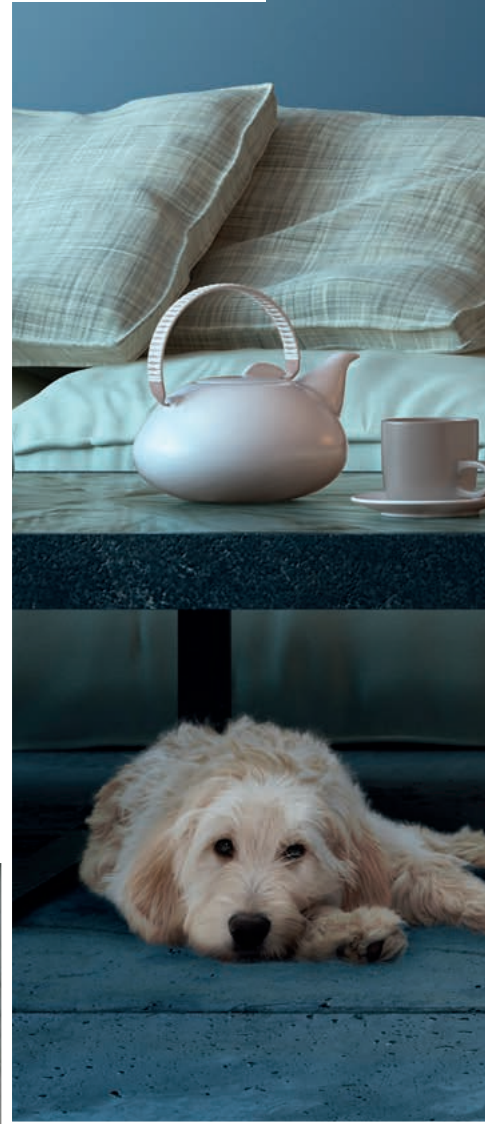



ebios-fire® Oxford 700

Renewable bioethanol makes it possible: The Oxford 700 combines the incomparable atmosphere of an open fireplace with a maximum of comfort. The 70 cm wide burner is specially designed for a larger space.

Just like its little brother, this **ebios-fire®** model is equipped with an integrated tank, which can hold approximately three litres of fuel – enough for five amazing hours of dancing flame. This model is designed to be wall-mounted or integrated completely with a protrusion of 5 cm, opening up new design options for various room concepts.

BURNER CASE FINISH



Nero

BURNER FINISH



Stainless steel,
brushed

FRAME FINISH



High-gloss black



High-gloss white



Stainless steel,
brushed



Chrome



Technical details, see page 85

INTERVIEW WITH DESIGNETAGEN

The Designetagen designer furniture exhibition in Potsdam offers customers unique designer furniture on the historical premises of the former royal lock and carriage smithery

This designer furniture exhibition makes the individualist's heart beat faster and makes you want to linger. In addition to the designer furniture exhibited here, Designetagen also offers unique, tailor-made furniture, dividers and accessories of a special kind. DESIGNETAGEN yearns to be discovered and holds a beautiful ambiance for anyone who decides to visit, with everything a connoisseur may want.

Thank you for sitting down for this interview with us! We look forward to learning more about you and your experiences with our ebios-fire® fireplaces. Which ebios-fire® model did you end up choosing?

We actually have several ebios-fire® appliances. My personal favourite is the ELIPSE Z. From the very start, this "Z" reminded me of the movie "ZORRO" starring Alain Delon, who used to be my favourite actor.

What is your favourite feature of the ELIPSE Z?

Its beautiful, calming, narrow flame.

How did you find out about us?

We discovered your fireplaces at a trade fair. Their simple, straight-lined shape and comfortable warmth immediately appealed to me. We value ambiance very highly and ebios-fire® fireplaces help us invoke emotion in our historical showrooms. I'm still completely thrilled and convinced of bioethanol fireplaces. They're clean.



There's no soot and no smell – it's the ideal solution for rented flats or houses without chimneys.

How often do you use your fireplace?

As often as we can. Of course we don't use it while it's hot and the sun is shining, but in the evening hours we do.

Do you have future plans involving ebios fire®?

I want to expand into the outdoor segment. So far I'm only presenting LA VELA GRANDE for this purpose. And I have already sold the CABINET FIRE as well – to a kitchen owned by the company Störmer.

Thank you for this interview and we hope you continue to enjoy our ebios-fire® fireplaces!



INFO BOX

DESIGNETAGEN GmbH

Posthofstraße 5
14467 Potsdam, Germany

Website: www.designetagen.de

Phone: +49 331 - 62646100



ebios-fire® Elipse Base Mini



ebios-fire® Elipse Base

ELIPSE BASE | ELIPSE BASE MINI

A MOBILE FLAME FOR ANY LOCATION

If you are always on the move and want to move and live in different places, a portable bioethanol burner is the perfect choice for you. High-quality appliances like the **ebios-fire®** Elipse captivate with a beautiful effect in any spot of the house or flat, be it on the dining table or next to the jacuzzi.

In addition, this mobile bioethanol burner creates a real camp-fire feeling when used outdoor in your garden or on your balcony instead of candles, lanterns, torches or tea lights.

It sounds like a tale from one thousand and one nights: Even the highest building in the world, the Burj Khalifa in Dubai, features our elegant living space accessories as part of its interior design.



BURNER CASE FINISH



Matt black

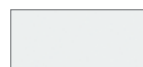

Matt white



Stainless steel,
brushed



Chrome

Technical details, see page 86

While evergreen potted plants and monotone flower arrangements used to be a common piece of decoration in living and shopping spaces when ideas were scarce, interior designers and professional furnishers have now discovered a completely new trend: "Flames instead of flowers" is today's motto for interior design experts.

For small spaces, one of the compact **ebios-fire**[®] Design Collection models is the perfect accessory: The Quadra Base. Its clear lines form a stark contrast to the lively dance of the fire, making it a real focal point for any room.



QUADRA BASE A MODERN CLASSIC



TÜV SÜD
certified
DIN 4734-1

BURNER CASE FINISH



Nero



Stainless steel,
brushed

GLASS FINISH



Black

Technical details, see page 86





ELIPSE Z

DYNAMIC DECORATION

The **ebios-fire®** model Elipse Z with its artistically curved base and its timeless and elegant steel-chrome design is a perfect example of fashionable living. The two glass panels attached alongside the flame protect the fire from any draft of air, but that's not all: They also reflect the flames in all their splendour.



BURNER CASE FINISH

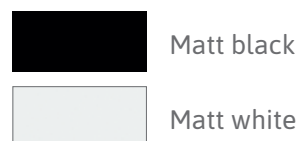

FOOT FINISH



Technical details, see page 87

LIVING TRENDS

Vibrant colours and contrasting colour combinations as well as trendy natural designs are a current favourite of interior designers.

Natural materials such as jute, viscose or wool form the foundation, while plant and animal themed decorations highlight this new interpretation of nature in design.

Organic shapes like the “Coral” lamp or the “Dot” vase which, with its varnished round elements, is reminiscent of a fish skin, add fascinating structures and patterns to living spaces.

A few personally selected, high-quality accessories are enough to turn a living space into a statement to perfectly reflect its inhabitants’ character.



DELICATE DINING ROOM DECORATION

These striking dining room chairs combine outstanding function with phenomenal comfort, quality without compromise and trendsetting design.

The delicate shape of the wire underframe of the table and chairs turns this seating area into a welcoming focal point in any dining or living room.

As seen at: Jab Anstoetz. Photo: www.jab.de

COLOUR OF THE YEAR: LIVING CORAL

Any seat can be made even comfier with a few well-placed cushions. These low-maintenance examples of an outdoor collection with a coral design will lift the mood of any space and add a hint of ocean. For a relaxing holiday feeling!

As seen at: www.hofdeco.com





“CORAL” BALL LIGHT BY DAVID TRUBRIDGE

Full of inspiration from his travels across the Pacific Islands, the renowned designer David Trubridge created this suspended ball light by the name of CORAL. It is world-renowned and yet unique, as the wood from which the ball light is made has a different characteristic marking on each lamp.

Photo: www.holzdesignpur.de

VASE “BALL”, BLUE-GREEN



Glossy vases in vibrant colours make a beautiful eye-catcher for any space. Choose them to match the colours of the furniture or as an exciting contrast! If you're lucky you'll find one at a garage sale - or you can get them brand-new from Housedoctor: Vase “Ball”. We chose this vase made of thick glass with a deep green glimmer.

Photo: www.housedoctor.com



VASE “DOT”

Is it a vase or a designer piece? – Both! With its varnished scales, the vase “Dot” is more reminiscent of a sculpture than a vase. This is a real statement piece, which is bound to appeal to people looking for a unique object with plenty of charm.

Photo: www.housedoctor.com



CARPETS

“Jardin” – the name says it all. Trendy floral patterns and tropical birds, not on wallpaper this time, but on low-maintenance carpet made of 100 % machine-woven polypropylene will brighten up any room.

Photo: www.benuta.de

NANO

DYNAMIC DANCING FLAMES IN A CRYSTAL CLEAR COLUMN

With its minimalist design and circular base with a diameter of only 33 cm, the **ebios-fire®** Nano, a state-of-the-art glass fireplace appears as a narrow fire column divided into two segments:

The burner case at the bottom is made of steel available in either a subtle Nero or in matt white, while a glass column encircles the flames at the top. But this designer piece has more to offer than an

impressive appearance. It is also equipped with state-of-the-art burner technology.

Even the twisting pattern of the flame can be adjusted by controlling the air supply. This gives the flame a more dynamic appearance with several levels that can be selected on an integrated touch display or on the remote control.



CASE FINISH



Nero

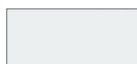

Matt white

Technical details, see page 87



PASSO E









A FIERY INTERIOR

The **ebios-fire®** Passo E combines the classic design of a stove with the perfected comfort of a modern bioethanol burner. This design offers not just a romantic fire in a clean and convenient way, but also perfectly exemplifies fashionable living culture.

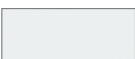
This “stove” is full of passion, practically in every way, from the circular design with a diameter of 48 cm to the generously dimensioned 180° panorama glass, which is perfect for showing off the flames on the imitation split logs. With its selection of eight attractive colours, this model suits any living space.

In addition to the touch display for simple control, the Passo E also has five levels for different flame heights and six timer programs. The Passo E model requires a chimney.

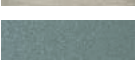
CLADDING FINISH

	Nero
	Titanium
	Pearl
	White
	Magnolia
	Nickel
	Metallic auburn
	Steel, polished and varnished
	Turquoise
	Light grey



Technical details, see page 87





LIBERTY

THE FIRE OF FREEDOM

The design of the **ebios-fire® Liberty** takes its inspiration from the famous **Statue of Liberty in New York**: It combines fire and three-dimensional art in a highly sophisticated manner. This luxury piece made of steel in a bronze design encloses a remote-controlled automatic burner.

A 5-litre canister stored in the base of Liberty is used for fuel supply. The hand opening up to the skies and holding a flickering flame is an impressive statement perfect for reception areas of hotels, restaurants and private residences.



CASE FINISH



Bronze

Technical details, see page 88



AVIATOR

AN HOMAGE TO THE PIONEERS OF AVIATION

This unique design is another rising star among **ebios-fire®** bioethanol fireplaces. The Aviator model's design was based on a radial engine as it was used in the early days of aviation.

The round, wall-mounted body is surrounded by a radial frame made of glass and metal bars – just like a propeller. But the body itself with its rivets is also reminiscent of the pioneer days of aircraft construction.



BURNER CASE FINISH



Oiled crude steel

FRONT RING FINISH



Chrome

Technical details, see page 88

STEEL

AN AUSPICIOUS EXAMPLE OF INDUSTRIAL CULTURE





Reminiscent of the early days of industrialisation, the **ebios-fire®** Steel captivates with its black, tube-shaped metal body, in which flames dance, creating a loft-like ambiance.

This compact bioethanol burner is small and easy to handle, making it the perfect fit for any living room or dining room table. Nevertheless, safety is a vital factor in its design. Its weight of eight kilograms allows it to stand securely on its own four feet.



BURNER CASE FINISH



Nero



Chrome

Technical details, see page 88

GARDEN TRENDS

Outdoor fashion is constantly changing and brings new products and trends to life every year. But fortunately high-quality classic designs are never out of fashion and true craftsmanship is a timeless classic.

So enjoy your personal freedom and let our classic designs for today and tomorrow inspire you.



PLACEHOLDERS WITH STYLE

Kettler's GRANNY side tables are a decorative highlight. Combined with these highly fashionable pouffes in dusky pink, black-berry or sand they add a whole lot of style to your space and provide a welcoming spot for a brief rest. This summer, don't miss out on a modern statement for indoors and outdoors.

Photo: KETTLER



SUSPENDED GRILL BY SCHICKLING

A stainless steel suspended grill is the perfect choice for anyone who values a durable design with great function. This sophisticated combination of a grill and a brazier can be fuelled with charcoal or split logs. The suspended grill moves any meat placed on the cooking grate in an oscillating circular movement, ensuring it is not exposed to permanent heat. This process makes for a particularly juicy meal.

Photo: www.schickling-grill.de



A SIMPLE IDEA BLOSSOMS INTO SOMETHING BEAUTIFUL

Wildlife conservation is the new outdoor trend.

A bee pasture is more than just a beautiful focal point for any garden. It also helps protect biodiversity. Plants that many gardeners view as “weeds”, such as dandelions, clover and goutweed offer pollinating insects an important food source and a refuge. And there’s another huge advantage: Busy bees make for a bountiful fruit harvest.



KETTLER SUNLOUNGER

Experience the beauty of relaxation! The comfortable EGO outdoor bed by Kettler doesn't just look fantastic, it feels fantastic too. The 5-position backrest allows for different seated or lying positions. Thanks to integrated wheels you can simply move the lounger to the sunny side of life – or to a quiet spot in the shade for a restful nap. This is what true relaxation looks like!

Photo: KETTLER







TOWER

AN IMPOSING SILHOUETTE

The stylish **ebios-fire**[®] Tower outdoor stove offers a 360° view of the dancing flames inside of it. The light reflections of this appliance invite you to dream.

The glass-and-stainless-steel fire column can be installed wherever you might want to gaze at romantic flames. The 150 cm high appliance is available in the trend colours Nero and white.

Its powerful warmth makes the **ebios-fire**[®] Tower a favourite for restaurant patios, but it is also a great focal point for hotel lobbies and arcades, warmly welcoming guests, visitors and customers. The **ebios-fire**[®] Tower is another proud winner of the Plus X Award for innovation, product quality and design.

Relaxing outside and forgetting the time is easy with an appliance that provides hours of fireplace romance. The **ebios-fire**[®] Tower outdoor stove doesn't just create a beautiful ambiance, it also provides pleasant warmth.



CASE FINISH



Nero



High-gloss white

Technical details, see page 89

ARCHITECTURE SL

AN AVANT-GARDE STATEMENT

Concrete is the foundation of a clear, consistent design language. Its angular body made of grey concrete with a changing structure, the contrasting black burner unit and the two discreet glass panes elegantly enveloping the fire make the **ebios-fire®** Architecture SL a true work of art.

A special manufacturing process and the characteristic properties of concrete as a material give the body a unique surface structure with infinitely variable nuances in hue – making every single Architecture SL a one-of-a-kind piece.



TÜV Süd
certified
DIN 4734-1

BURNER CASE FINISH



Nero

BASE FINISH

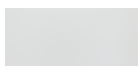

Concrete

Technical details, see page 89



LA VELA MIDI | LA VELA GRANDE

CANDLES IN A WHOLE NEW LIGHT

Imagine the perfect evening with delicious food, fine wine, soft music, in a beautiful ambiance with pleasant company. The only thing missing in this image is the right kind of illumination. Forget dripping tallow candles! Now there is an alternative to give your night that extra bit of elegance: La Vela – Spanish for “The candle”.

La Vela is a stylish way of putting the spotlight on fire. You have a choice between La Vela Midi, the smaller model for tables or walls, and La Vela Grande, the fire column for flames of up to 15 cm in height. All models are available in three sizes.

A straight-lined design, engineering precision and a high degree of safety are combined to create a harmonious triad of beauty.

These passionate fireplaces made of glass and stainless steel are the perfect stage for a sophisticated fire display. Like all **ebios-fire®** products, La Vela follows the principle “Safety first”. A flame symbol turns red once the burner has heated up to prevent burn injuries. This product is the perfect mix of a Mediterranean temperament with safety engineering “made in Germany”.



VERSION FINISH



Stainless steel,
brushed

WALL-MOUNTING FINISH



VAG/chrome

Technical details, see page 89





INTERVIEW WITH SK STRANDKÖRBE & KAMINE

The Berlin-based beach chair and fireplace provider SK Strandkörbe & Kamine has been established on the market for over 26 years. As the extensive range of garden beach chairs is purely a summer business, ethanol fireplaces have proven to be the ideal product for supplementing business year-round since 2006.

In an extensive fireplace exhibition, interested visitors can experience various **ebios-fire**[®] models for themselves: Chelsea, Eclipse-Wall, Eclipse Z, Eclipse Base Mini, Fuora R, Aviator and all La Vela models.

Thank you for taking the time for this short interview. We would like to learn more about you and your company. What made you decide to add ebios-fire[®] ethanol fireplaces to your product range?

We love selling **ebios-fire**[®] fireplaces, because their burner system is incredibly safe and all fireplace models have a gorgeous, elegant design. The workmanship and all the materials used are also of a very high quality.

Last but not least, we were impressed by the extensive selection, as **ebios-fire**[®] offers a lot of elegant, unique designs. We advise architects, among other people, and try to find the right fireplace model for each and every interested customer. **ebios-fire**[®] offers tailor-made products and, just in general, a product range which leaves other fireplace manufacturers unable to compete.





Paint us a picture of an exhibition for bioethanol fireplaces!

In the reception area, our customers are welcomed by the sight of three “La Vela Grande” columns. We try to include all styles in our fireplace exhibition: Rustic fireplaces like in a mountain cabin, framed fireplaces reminiscent of the era of Louis IV, modern column designs, wall-mounted or stand-alone, the good old stove or unique models like the **ebios-fire® Aviator**.

Our customers are big fans of the modern, exclusive design of **ebios-fire®** fireplaces and the wide yet calming flame pattern of wick burners.

Thank you for for taking the time for our interview. We wish you ongoing success in selling our ebios-fire® fireplaces!

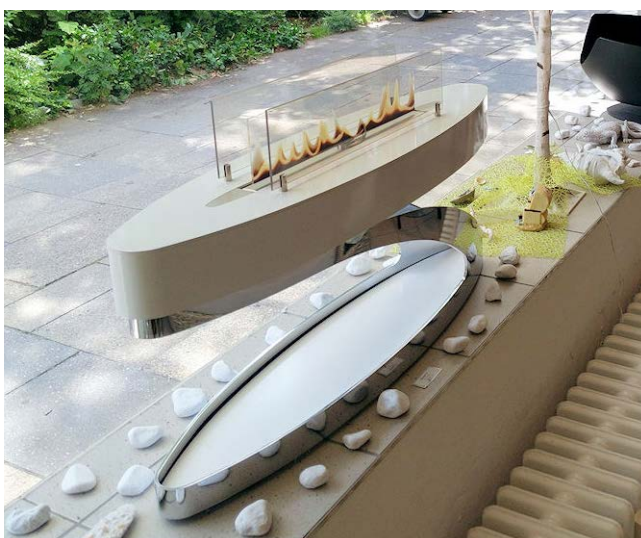
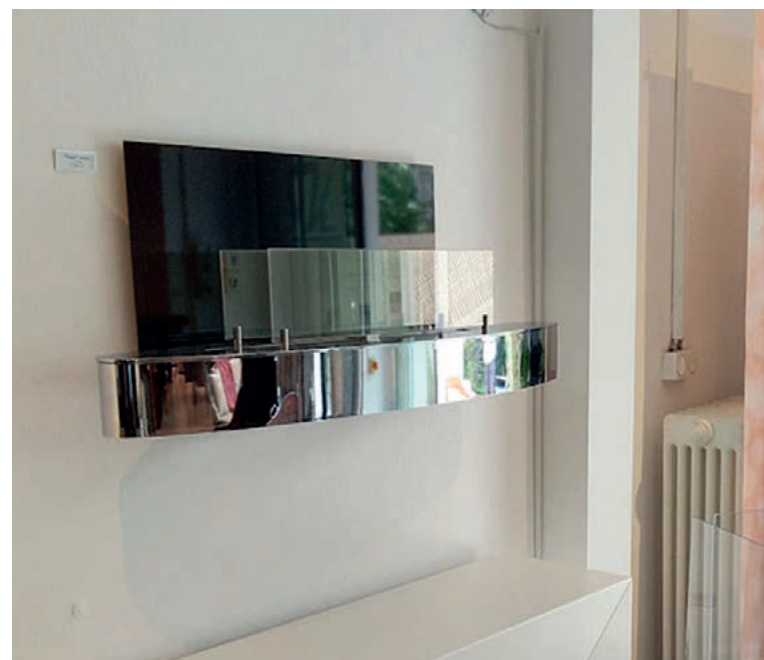

INFO BOX

SK Strandkörbe & Kamine
Owner Stephan Kosser
Falkenseer Chaussee 21
13583 Berlin, Germany

Website: www.strandkorb-berlin.de
Phone: +49 30 - 83031512



BUILT-IN FIREPLACES: THE ARCHITECTS COLLECTION



FIREPLACES AS AN ELEMENT OF INTERIOR DESIGN

The **ebios-fire**® Architects Collection was designed especially for interior designers and furnishing specialists and contains bioethanol burners, fireplace inserts and built-in fireplaces with various layouts and finishes.

With the choice between manually operated wick burners and electronically controlled automatic burners, it is amazingly simple to create an eye-catching centrepiece.

A VISION BECOMING REALITY

FINDING THE RIGHT FIREPLACE FOR ANY ROOM

The lively dance of flames in a fireplace represents comfort, relaxation and an elegant lifestyle. Of course, you need a chimney to forget your everyday worries in the glow of the flames – or at least you do, if you install a conventional fireplace.

A built-in bioethanol fireplace, on the other hand, can be installed in any room. Bioethanol, a fuel made from renewable resources, burns completely without ash or smoke, meaning that built-in **ebios-fire®** fireplaces require neither chimneys nor flues.

Whether you are planning to install an attractive fire centrepiece in your customer's office or house, a hotel reception area or your own home: our custom-made bioethanol fireplaces offer unimagined possibilities. With variable layouts and finishes the only limits are those of your imagination. Our experts will gladly assist you in turning a sketch of your ideas and visions into a marvellous fire centrepiece.

Tell us your ideas, so that we can help you in every way possible to realise your project of creating a safe, efficient **ebios fire®** fireplace. Our built-in fireplace models are ideal for installation in walls made of brick, aerated concrete or plasterboard panels. All **ebios-fire®** built-in fireplaces are factory-insulated and can therefore be inserted with ease.





BUILT-IN FIREPLACES INSULATED



The **ebios-fire®** built-in fireplace models are ideal for installation in walls made of brick, aerated concrete or plasterboard panels without having to consider the need for a chimney or flue when building the wall around the fireplace.

This range of models includes six layouts in various sizes, which can be fitted either with the **ebios-fire®** manual wick burner or the automatic burner.

Glass panels mounted on the burner reflect the elegantly flickering flames multiple times to top off the appearance.

All ebios-fire® built-in fireplaces (1V, FD, 2R, 2L, U, C) are already factory-insulated and can therefore be used with combustibile materials without any problems. Custom-made units can be produced on request.





Built-in fireplace 1V

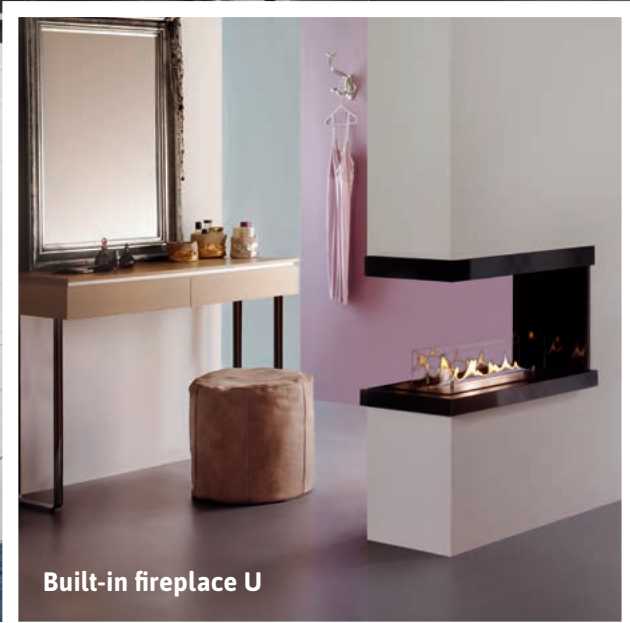

Built-in fireplace U



Built-in fireplace 2R



Built-in fireplace FD



BUILT-IN FIREPLACES: BURNING PASSION - ANYWHERE

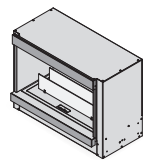

1V

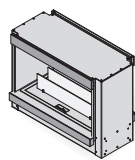

FD

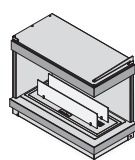

2R

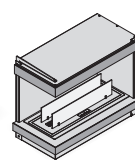

2L

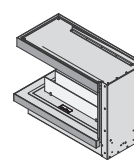

U

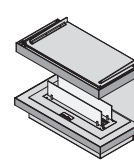

C

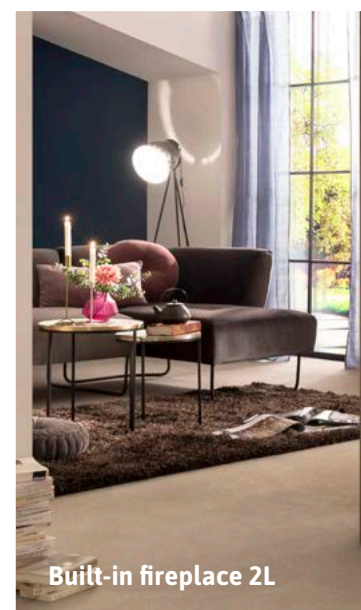

Built-in fireplace 2L



If you are looking to enjoy the romantic atmosphere of a warm fireplace, a built-in bioethanol fireplace is the perfect choice for you. Install it in your living room, in the kitchen, in the dining room, even in the bathroom – **ebi-os-fire®** built-in models are fireplaces for “anywhere”.

Bioethanol, a fuel made from renewable resources, burns completely without ash or smoke. This opens up options for diverse room design that would be impossible with a conventional fireplace.



Built-in fireplace C

BURNER CASE FINISH



Powder-coated Nero

BURNER FINISH



Nero



VAG

FRAME PANEL FINISH



Black steel



Glass ceramic

Technical details, see page 90

THE CITY

THIS FIREPLACE IS READY TO GO OUT ON THE TOWN



New apartment complexes, business towers and shopping centres have one thing in common – nowadays they usually don't have chimneys. Frequently, this makes it impossible to install a fireplace, even though a fireplace is the ideal design feature to perfect modern architecture and fashionable living space design and to create ambiance highlights.

Fortunately, bioethanol fireplaces like the **ebios-fire®** model The City have no need for a chimney or flue.

This designer fireplace combines timeless elegance and engineering precision. It is surrounded by a classic fireplace frame, creating a captivating impression.



BUILT-IN FIREPLACE FINISH



Chrome

BURNER CASE FINISH



Nero



Technical details, see page 92

CABINET FIRE

RETURNING THE HEARTH TO THE KITCHEN

We wanted to return fire in its original form to the place where it has been at home throughout human history: the kitchen.

Our engineers and designers were happy to take on the challenge.

The **ebios-fire®** built-in fireplace Cabinet Fire makes seamless integration of fire in any kitchen range a reality. But once again, there is no limit but your imagination. If you would prefer to install this fireplace in your living room shelf unit, you can. Anything goes.

Simple installation in the standardised 60s kitchen size is possible without any problems.



GLASS FINISH



Black (glass ceramic)

BURNER CASE FINISH



Nero

Technical details, see page 92





FOOD TRENDS

There are many ways to experience enjoyment. Take the warmth and lively flames of our ebios-fire® fireplaces – or else a delicious meal and drink, served in beautiful tableware. Fresh, balanced food, a fine wine and stimulating conversations are what turns a meal into a social experience which nourishes not just the body, but the soul. This is the true meaning of “soul food”!



BLACK ...

... is the new black, after all. This designer silverware set by Gense, designed by Monica Förster, proves as much. After silver, gold and copper, black has become the new trend colour for kitchens, not just for appliances, but also for tableware. Contrasting beautifully with rustic earthenware, it truly draws the eye.

Photo: www.gense.se

BOWL, LAKE, GREY

Earthenware is at the height of fashion. Its somewhat rustic appearance is simple and timeless, while its colours follow the latest trends. This bowl “Lake” by Housedoctor has just the right look to fit seamlessly into any space. Thanks to its glazing, every bowl is one of a kind. Whether you decide to fill it with a dip or a rich Buddha bowl, “Lake” creates a welcoming atmosphere, perfect for sitting back and relaxing. It’s the ideal vessel for soul food!

Photo: www.housedoctor.com



A FAVOURITE FOR ANY SEASON

Rosé Saigner 2018 of the Palatinate wine-growing region is both hearty and fruity. Notes of blackberry, raspberry and blackcurrant characterise this delicious mixture of St. Laurent, Merlot, Cabernet Sauvignon and Pinot Noir. A fruity reminiscence of summer, this wine is perfect for balmy evenings spent outdoors or autumn and winter nights curled up by a blazing fire.

Photo: www.black-print.net

Markus Schneider 2018 Rosé Saigner
Dry, Germany, Palatinate



FOOD TREND: BUDDHA BOWLS

This trend takes its name from the delicious ingredients forming a bulging mountain in a bowl, almost like a round Buddha's belly.

The ingredients are anything you fancy, ideally some of everything: Pulses or quinoa, complex carbohydrates, for instance whole wheat pasta, rice or sweet potatoes and, of course, crisp vegetables like carrots, bell peppers, tomatoes and more. Last but not least, healthy fats like those in avocados or nuts turn a Buddha bowl into a healthy, balanced meal.

Photos: [instagram.com/cardaoakler](https://www.instagram.com/cardaoakler)



WHITE WINE GLASS, SPECTRA



A fine wine is not something you just drink. It's something you take your time to enjoy. To add to the enjoyment, serve it in a unique glass that masterfully represents the balance of Bohemian style and modern classics - such as the inimitable "Spectra" glass by Housedoctor. This Danish design company is regarded as an insiders' tip among German interior design specialists. It's well worth a look: www.housedoctor.com

HONEY-GLAZED SALMON

Ingredients for 2 people

- 2 pieces of salmon fillet, approx. 150 g per piece
- 1 tablespoon of liquid honey
- 4 tablespoons of lime juice
- ¼ teaspoon of salt
- A generous pinch of chilli powder
- A pinch of pepper

Mix the honey, chilli powder, salt and pepper and stir to make a marinade. Wash and pat dry the salmon, then coat it with the honey marinade. Heat butter in a pan, fry the salmon in the pan for approx. 2 minutes on each side. Sprinkle with the remaining lime juice. Serve on a plate with a fresh salad. The dish tastes great with baguette.



FIREPLACE INSERTS - MADE TO MEASURE





LET YOUR IMAGINATION RUN FREE

Have you designed your house based on your own ideas and desires, so now you don't want to fill it with mass-produced furniture and art? Then a made-to-measure **ebios-fire**[®] fireplace insert is the perfect choice for you.

As one of only very few manufacturers, **ebios-fire**[®] offers tailor-made special designs. Our designers and engineers combine their manual skills with machine-based production processes, mixing craftsmanship with high-tech to create the perfect fireplace insert for you.

These easy to install fireplace inserts can be equipped with either a manual wick burner or an automatic burner. All fireplace models come with a detailed technical drawing and a clear installation manual.





KENSINGTON

FOCUS ON ESSENTIALS

The **ebios-fire®** fireplace insert Kensington is a tailor-made appliance characterised by a minimalist design without a prominent frame. It goes without saying that the interior of this designer piece is equipped with state-of-the-art technology. This fireplace insert is available with a wick burner or an automatic burner.

The automatic burner comes with a remote control for even greater ease of use: In addition to convenient activation and deactivation, it also provides an option for selecting from different flame heights. This high-quality bioethanol fireplace creates a beautiful atmosphere at the push of a button – be it for a relaxed family dinner or a classy evening with friends.



BURNER CASE FINISH

 Nero

Technical details, see page 92

INTERVIEW WITH KÜCHENTREFF JUNKER

KüchenTreff Junker is a second-generation family business founded in Erfstadt in 1979 by Hermann Junker, initially with the name of “Trend Küchen”. The company has now existed for 40 years and has grown steadily in this time. Its exhibition presents over 40 model kitchens in a space of over 1,000 m².

Thank you for sitting down for this interview with us! We look forward to learning more about you and your experiences with our ebios-fire® fireplaces. Which ebios-fire® model did you end up choosing?

For our exhibition spaces, we chose the fireplaces Cabinet Fire and Quadra Inside I SL.

What made you choose these fireplaces in particular?

Both of them are a wonderful addition to our kitchens, as ebios-fire® fireplaces exude warmth and cosiness. We want to grab our customers by their emotions, so we needed to find an effective way to emphasise the ambiance of our kitchens. In addition to the beautiful flame pattern, it was the simplicity with which these fireplaces can be handled and installed that gave us the final push.

What is your customers’ reaction when they see bioethanol fireplaces as a fixed component of your kitchens?

It’s very positive! We often hear: “Oh, what is that? Very interesting, very beautiful. Where could I install something like that in my kitchen?”, or else: “I’ve seen something like this before but I didn’t know where to get it!” – Well, from us, of course!

What has been your everyday experience working with ebios-fire® fireplaces?

It has all been going perfectly! There hasn’t been any damage to the kitchens. The fireplaces bring an entirely new mood to our kitchen studio and to the kitchens themselves. Everything is suddenly much more homelike and comfortable, but also feels more personal and our customers immediately feel right at home.



What was it like to install the ebios-fire® fireplaces?

The installation itself was very simple, although the Cabinet Fire is quite heavy, so it's best to have 2 people working on it. Operating the fireplaces, on the other hand, is incredibly easy. Just fill in bioethanol and turn them on!

Thank you for this interesting interview, Mr. Junker, and we hope you continue to enjoy your ebios-fire® fireplaces!

INFO BOX

KüchenTreff Junker GmbH
Zunftstraße 15
50374 Erftstadt, Germany

Website: www.kuechentreff-junker.de
Phone: +49 2235 - 74055



CHELSEA

TIMELESS ELEGANCE TO FRAME THE FLAMES

The fascinating effect of the flickering flames makes the **ebios-fire®** Chelsea fireplace insert a true design highlight.

Its elegant, 50 mm wide frame made of brushed stainless steel is an eye-catching adornment for this unique fireplace insert. On request, the frame is available in different colours.



BURNER CASE FINISH



Nero

FRAME FINISH



Stainless steel,
brushed

Technical details, see page 93





QUADRA INSIDE SL

A PASSIONATE AMBIANCE JUST FOR YOU



The **ebios-fire**® built-in model Quadra Inside SL offers a great degree of design flexibility: This innovative bioethanol burner is suitable for seamless integration into customised furniture and panelling. But that's not all: This fireplace can even be integrated in existing furnishings, anywhere from worktops to sideboards and even in dining tables.

The glass panels surrounding the burner don't just reflect the fascinating flame pattern, they also contribute to the appliance's safety.



BURNER CASE FINISH



Nero



Stainless steel,
brushed

Technical details, see page 93

QUADRA INSIDE AUTOMATIC SL

STYLE AND AMBIANCE AT THE PUSH OF A BUTTON

The elongated model **ebios-fire®** Quadra Inside Automatic SL with a burner channel of either 50 or 100 cm length is convenient to operate thanks to its remote control.

Instead of an internal tank, this model has an external fuel supply. An electronic pump system supplies bioethanol directly from the canister to the burner via supply tubes, permitting extremely long operating times.

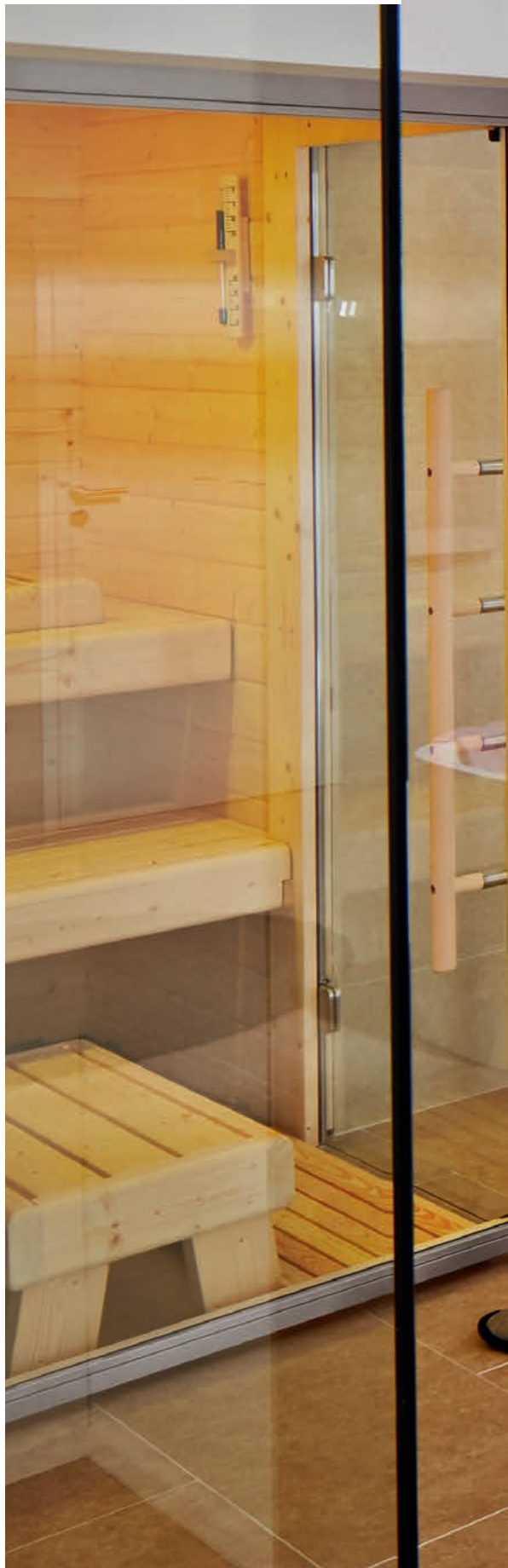

TOP PLATE FINISH



Nero



Stainless steel,
brushed

Technical details, see page 93





EBIOS ONE 500 / 500 PLUS

AT THE FOREFRONT OF PROGRESS



This burner is a prime example of engineering perfection, in terms of safety, comfort and air quality. Bioethanol, initially in its liquid form, is pumped to a special chamber, where it is heated, causing it to evaporate. As a gas, it is then burned in the fire channel, generating practically zero odour.

This system is not just incredibly safe, it also ensures perfectly clean combustion without odours – from the very first second. A three-level fuel supply ensures even greater user friendliness.

This appliance's essential features include the following: The Ebios ONE 500 can be controlled via an app or remote control and includes a timer function. It is compatible with Smart Home technologies.

In the event of jolting or operating errors, the safety function is triggered and immediately shuts down the appliance.



¹⁾

¹⁾ applies only to Ebios ONE 500 plus

TOP PLATE FINISH



Nero



Stainless steel,
brushed

Technical details, see page 94

EBIOS ONE 1000

IMPOSING FLAMES STAGED WITH STYLE



This luxury burner heats and vaporises liquid bioethanol. The resulting flame burns evenly, is completely odourless and can be adjusted in height as desired: The available options are 5, 9 or 12 cm.

The flame pattern measures a full metre in length – and can be expanded to form an imposing line of fire through combination of several burners connected in series and controlled together via an app or remote control.

The EBIOS ONE 1000 is the flagship among our bioethanol appliances. It goes without saying that it can be integrated seamlessly into existing Smart Home systems and represents the state of the art of fashionable living.



TOP PLATE FINISH



Nero



Stainless steel,
brushed

Technical details, see page 94



SAFETY

DESIGNED WITH CARE AND TÜV-CERTIFIED

The combination of liquid fuel, people and an open flame can be a dangerous one. That is why we have designed all **ebios-fire**® fireplaces with a maximum of user safety and intuitive operating processes in mind.

All **ebios-fire**® appliances are extensively tested in our factory laboratory where we monitor fuel consumption, heat output, flame behaviour and material durability. Furthermore, the majority of **ebios-fire**® burners and fireplace models is tested and certified by the TÜV inspection association.

All **ebios-fire**® appliances leave the factory lab-tested and carefully packaged. Each burner features safety symbols intended to supplement the detailed user manual and help users handle their **ebios-fire**® fireplace safely.

Furthermore, a user manual is included with each fireplace, providing the user with valuable information about the appliance, its installation, use and maintenance as well as about the required bioethanol.

CUSTOMER RESPONSIBILITY FOR SAFE OPERATION

Although we dedicate great effort to making **ebios-fire**® fireplaces as safe as possible to give our customers a thoroughly positive experience, it is our customers themselves who bear the final responsibility for safe operation of their fireplaces.

Therefore, we would like to emphasise the importance of adhering to the following safety rules: Familiarise yourself with the safety requirements listed in the user manual of your **ebios-fire**® fireplace and ensure that everyone who will be operating the fireplace is familiar with them as well.

We strongly advise against any modification of components or the design of **ebios-fire**® appliances. This includes the use of decorative ceramic items like logs or pebbles in the flames.

ROOM AIR QUALITY

Contrary to common believe, it is not primarily the consumption of oxygen which decreases the room air quality, but rather the formation of CO₂. Carbon dioxide is a trace gas which occurs naturally in air, but is also produced by plants, animals, humans and – of course – any combustion process like the burning of bioethanol.

2 people will generate approximately 75 g of CO₂ per hour. A fire burning 0.5 litres of bioethanol per hour will generate 740 g CO₂.

The second factor influencing the room air quality is the consumption of oxygen. Air with an average quality contains approximately 21 % of oxygen. This means that a room of 40 m² with a ceiling height of 2.5 m (100 m³) contains 27 kg of oxygen.

Last but not least, the air exchange rate is a crucial factor which helps to compensate for both CO₂ emission and oxygen consumption.

In order to keep the indoor climate at its best, i.e. the room air quality as high as possible during operation of a bioethanol fire, it is essential to carefully plan the size of the burner considering the room size, its volume and ventilation.

Our qualified **ebios-fire**[®] team is here to help with expert advice.

TECHNOLOGY

As a core element of our range of **ebios-fire**[®] bioethanol fireplaces, wick, automatic and vaporising burners offer a wealth of possibilities.

THE WICK BURNER



The patented technology used in **ebios-fire**[®] wick burners permits zero-deflagration ignition of the burner, which is TÜV-tested and certified according to DIN 4734-1 or DIN EN 16647.

This makes the **ebios-fire**[®] wick burner one of the safest bioethanol burners currently on the market.

The volume of the burner tanks, which are pressure tested during production, varies in accordance with the burner size, just like the heat output.

The wick burner is an integral part of most **ebios-fire**[®] Design Collection models. Glass panels in front of and behind the flames don't just reflect the mesmerising

Without the need for a flue or chimney, installation is possible just about anywhere.

flames multiple times, but also contribute to the burner's safety and function.

Safety features

- Pressure-tested tank
- Filling level display
- Safety tank lock
- Pressure relief valve

The fuel tank lock and wick system prevent bioethanol from spilling if the burner is tipped over.

THE AUTOMATIC BURNER



The remote-controlled **ebios-fire**[®] automatic burner uses pumps to transport liquid bioethanol to a 500 mm or 1000 mm wide burning channel, where it is ignited.

The bioethanol supply is stored in 5 litre canisters, which can be stored either under the burner or at a storage location further away.

Safety features

- Filling level sensors in the burning channel
- Temperature sensors
- Automatic shut-down after 8 hours of continuous operation
- Acoustic warning signal in the event of a malfunction
- Overflow sensor

THE VAPORISING BURNER



This is the first burner with a vaporising system that meets the extreme demands of DIN EN 16647. Prior to combustion, the ethanol is heated to approx. 80°C in a separate vaporising chamber, from which it is then guided to a burning channel as a gas.

In this section, the vapour is burned at a higher temperature level than in conventional ethanol burners, thereby significantly reducing the odours generated by ethanol combustion.

Safety features

- Temperature sensors
- Leakage sensors
- External input for CO₂ detector
- Impact sensor
- Tilt sensor
- Ethanol level sensor in the tank and in the vaporising chamber
- Monitoring of many safety-relevant components

“DESIGN WITHOUT ENGINEERING
IS DREAMING;
ENGINEERING WITHOUT DESIGN
IS PURE FUNCTION.”

based on a quote by Steven K. Roberts



TECHNICAL DETAILS

ELIPSE WALL

Front

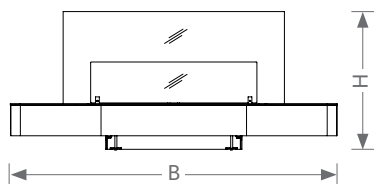

Side

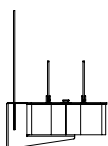

Tunnel

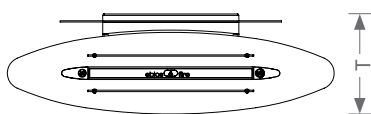

ELIPSE WALL MINI

Front

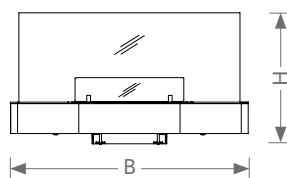

Side



Tunnel

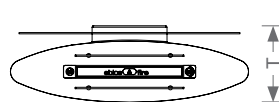

QUADRA WALL

Front

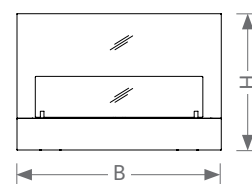

Side

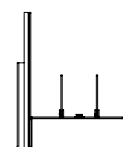

Tunnel

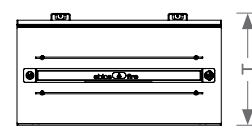

Dimensions W/H/D	960 / 405 / 293 mm	700 / 385 / 225 mm	600 / 400 / 328 mm
Materials	Steel, stainless steel, heat-resistant glass ceramic	Steel, stainless steel, Toughened safety glass	Steel, stainless steel, heat-resistant glass ceramic
Weight	approx. 24.0 kg	approx. 13.0 kg	approx. 25.0 kg
Burner type	TÜV certified wick burner EB 500	Wick burner EB 300	TÜV certified wick burner EB 500
Fire line	approx. 500 mm	approx. 300 mm	approx. 500 mm
Filling capacity	2.60 litres	1.20 litres	2.60 litres
Minimum room volume	84 m ³	40 m ³	84 m ³
Minimum room area	34 m ²	16 m ²	34 m ²
Burning duration	up to 5 hours	up to 3 hours	up to 5 hours

CAMBRIDGE 600

Front

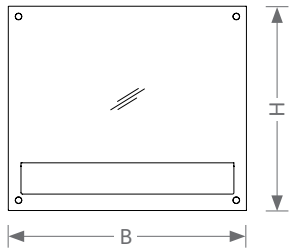

Side

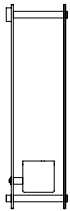

Tunnel

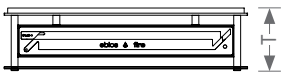

OXFORD 600

Front wall-mounted/built-in

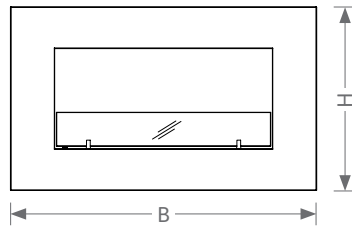

Side/Tunnel
wall-mounted

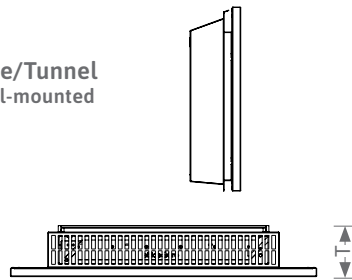

Side/Tunnel
built-in

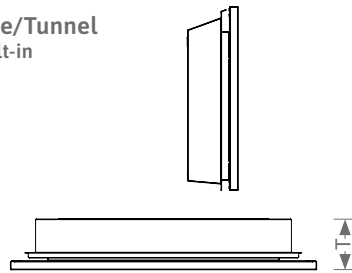

OXFORD 700

Front wall-mounted/built-in

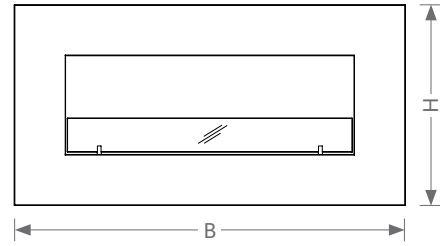

Side/Tunnel
wall-mounted

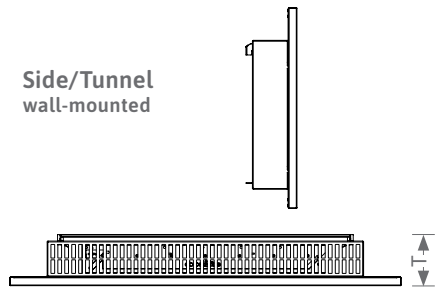

Side/Tunnel
built-in

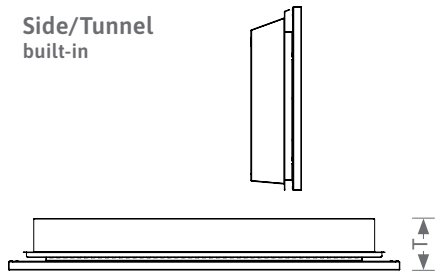

700 / 600 / 180 mm	900 / 540 / 150 mm	1150 / 590 / 150 mm wall-mounted 1150 / 590 / 151 mm built-in	Dimensions W/H/D
Aluminium, stainless steel, Toughened safety glass	Steel, stainless steel, heat-resistant glass ceramic	Steel, stainless steel, heat-resistant glass ceramic	Materials
approx. 27.0 kg	approx. 21.0 kg wall-mounted model approx. 29.0 kg built-in model	approx. 27.0 kg wall-mounted model approx. 37.0 kg built-in model	Weight
Wick burner S 600	Wick burner S 600	Wick burner S 700	Burner type
approx. 550 mm	approx. 550 mm	approx. 600 mm	Fire line
2.47 litres	2.47 litres	2.88 litres	Filling capacity
96 m ³	96 m ³	111 m ³	Minimum room volume
38 m ²	38 m ²	44 m ²	Minimum room area
up to 5 hours	up to 5 hours	up to 5 hours	Burning duration

TECHNICAL DETAILS

ELIPSE BASE

Front

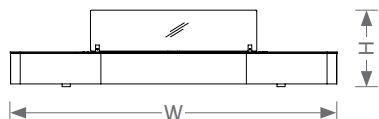

Side



Tunnel

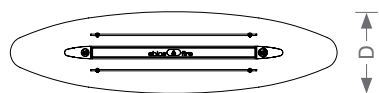

ELIPSE BASE MINI

Front

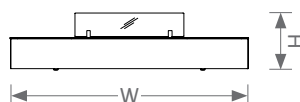

Side



Tunnel

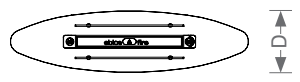

QUADRA BASE

Front

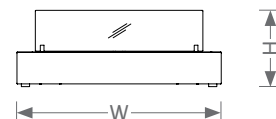

Side

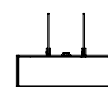

Tunnel

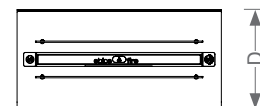

Dimensions W/H/D	960 / 215 / 240 mm	700 / 168 / 180 mm	600 / 224 / 292 mm
Materials	Steel, stainless steel, heat-resistant glass ceramic	Steel, stainless steel, Toughened safety glass	Steel, stainless steel, heat-resistant glass ceramic
Weight	approx. 24.0 kg	approx. 10.5 kg	approx. 19.0 kg
Burner type	TÜV certified wick burner EB 500	Wick burner EB 300	TÜV certified wick burner EB 500
Fire line	approx. 500 mm	approx. 300 mm	approx. 500 mm
Filling capacity	2.60 litres	1.20 litres	2.60 litres
Minimum room volume	84 m ³	40 m ³	84 m ³
Minimum room area	34 m ²	16 m ²	34 m ²
Burning duration	up to 5 hours	up to 3 hours	up to 5 hours

ELIPSE Z

Front

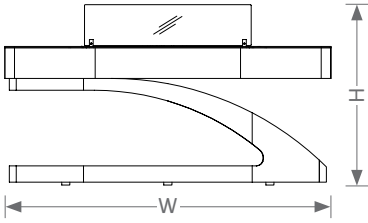

Side

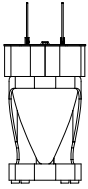

Tunnel

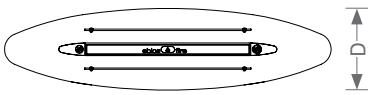

NANO

Front

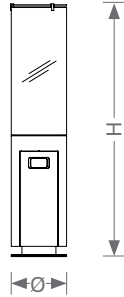

Side



Tunnel



PASSO E

Front

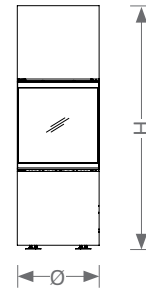

Side

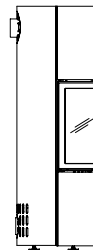

Tunnel



960 / 530 / 240 mm

Steel, stainless steel,
heat-resistant glass ceramic

approx. 44.5 kg

TÜV certified wick burner EB 500

approx. 500 mm

2.60 litres

84 m³

34 m²

up to 5 hours

Ø 325 / 1480 mm

Steel, stainless steel,
heat-resistant glass ceramic

approx. 47.0 kg

Automatic burner, 5 power levels,
2 flame types, including remote control

–

1 x 5.0 litre canister*

100 m³

40 m²

up to 5 hours at power level 5

Ø 481 / 1431 mm

Steel, stainless steel,
heat-resistant glass ceramic

approx. 140.0 kg

Automatic burner, 5 power levels

–

1 x 5.0 litre canister*

–

–

up to 5 hours at the highest power level

Dimensions
W/H/D

Materials

Weight

Burner type

Fire line

Filling capacity

Minimum
room volume

Minimum
room area

Burning
duration

TECHNICAL DETAILS

LIBERTY

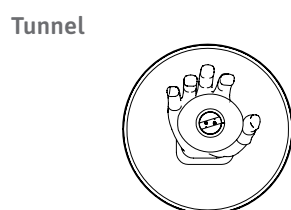
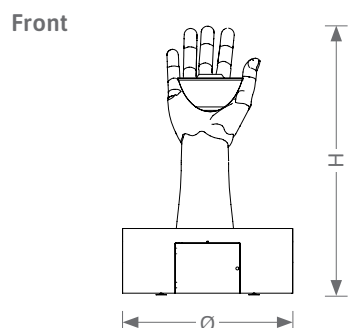

AVIATOR

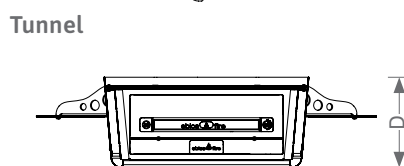
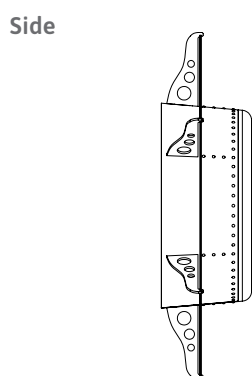
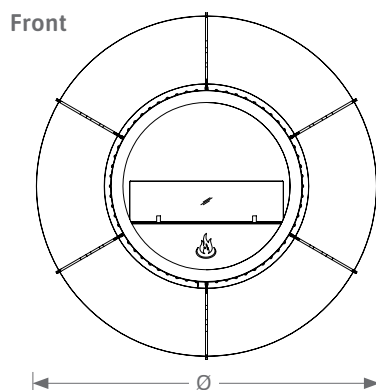

STEEL

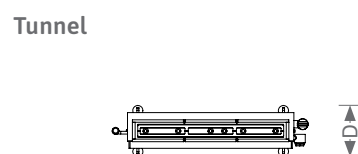
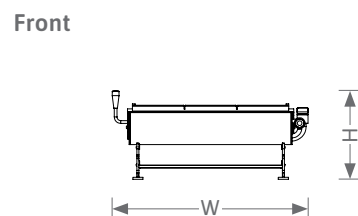

Dimensions W/H/D	Ø 1000 / 1600 mm	Ø 1000 / 265 mm	576 / 222 / 105 mm
Materials	Steel, stainless steel, lava stones	Steel, stainless steel, Toughened safety glass	Steel, stainless steel, Stainless steel or Nero finish
Weight	approx. 90.0 kg	approx. 30.0 kg	approx. 8.0 kg
Burner type	Automatic burner, 2-level flame height	Wick burner EB 300	Wick burner
Fire line	–	approx. 300 mm	approx. 500 mm
Filling capacity	1 x 5.0 litre canister *	1.20 litres	2.20 litres
Minimum room volume	270 m ³	40 m ³	84 m ³
Minimum room area	108 m ²	16 m ²	34 m ²
Burning duration	up to 6 hours at power level 1	up to 3 hours	up to 5 hours

ARCHITECTURE SL

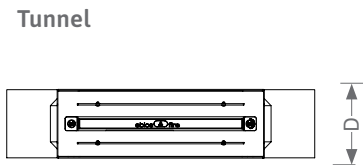
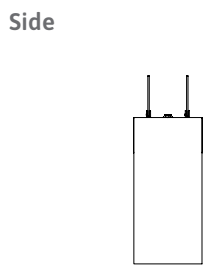
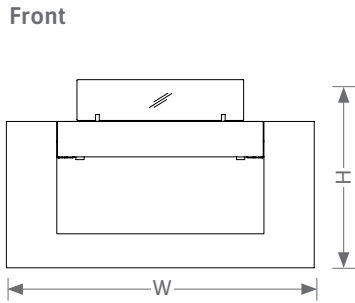

TOWER

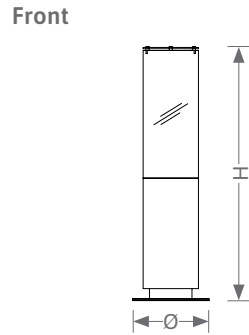

LA VELA MIDI

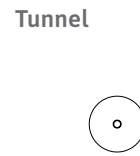
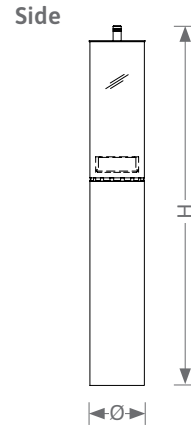

LA VELA GRANDE

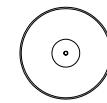
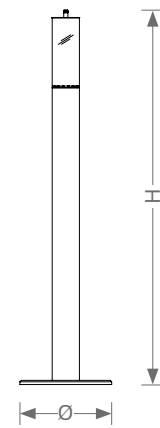

905 / 552 / 202 mm	Ø 450 / 1493 mm	Ø 82 / 428 (478/528) mm	Ø 270 / 1000 (1100/1200) mm	Dimensions W/H/D
Steel, stainless steel, concrete, heat-resistant glass ceramic	Steel, stainless steel, safety glass	Stainless steel, including glass cylinder	Stainless steel, including glass cylinder	Materials
approx. 40.0 kg	approx. 64.0 kg	approx. 1.6 1.8 2.0 kg	approx. 11.0 12.5 14.0 kg	Weight
TÜV certified wick burner EB 500	Automatic burner, 2-level flame height, including remote control	Wick burner	Wick burner	Burner type
approx. 500 mm	–	–	–	Fire line
2.60 litres	1 x 5.0 litre canister *	0.5 litres	0.5 litres	Filling capacity
84 m ³	172 m ³	–	–	Minimum room volume
34 m ²	69 m ²	–	–	Minimum room area
up to 5 hours	up to 6 hours at flame level 1	up to 6 hours	up to 6 hours	Burning duration

*not included

TECHNICAL DETAILS

Built-in fireplace 1V

Front

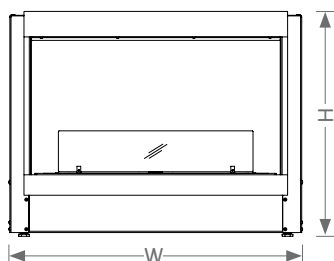

Side

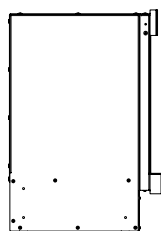

Tunnel

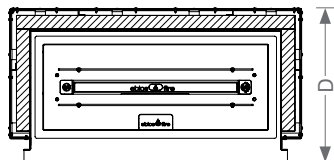

Built-in fireplace FD

Front

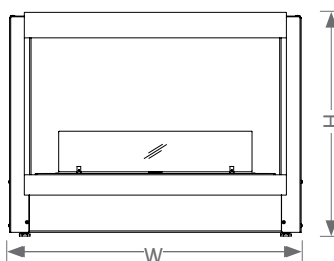

Side

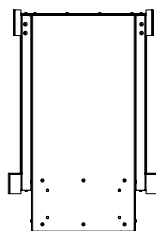

Tunnel

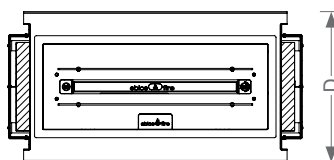

Built-in fireplace 2L

Front

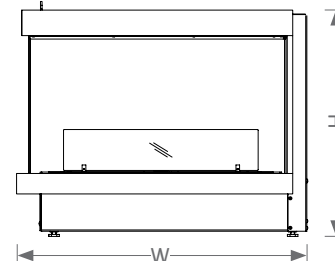

Side

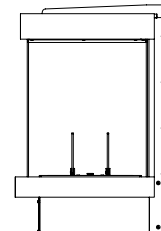

Tunnel

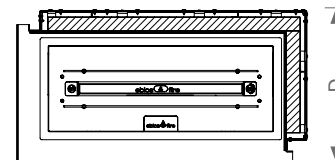

Dimensions W/H/D	858 / 661 / 450 mm	862 / 661 / 442 mm	853 / 665 / 450 mm
Materials	Steel, black glass, insulation materials	Steel, black glass, insulation materials	Steel, black glass, insulation materials
Weight	approx. 93.0 kg	approx. 73.0 kg	approx. 93.0 kg
Burner type	Wick burner or automatic burner incl. remote control	Wick burner or automatic burner incl. remote control	Wick burner or automatic burner incl. remote control
Fire line	approx. 500 mm	approx. 500 mm	approx. 500 mm
Filling capacity	Wick burner: 2.60 litres Automatic burner: 1 x 5.0 litre canister*	Wick burner: 2.60 litres Automatic burner: 1 x 5.0 litre canister*	Wick burner: 2.60 litres Automatic burner: 1 x 5.0 litre canister*
Minimum room volume	84 m ³	84 m ³	84 m ³
Minimum room area	34 m ²	34 m ²	34 m ²
Burning duration	Wick burner up to 5 hours Automatic burner up to 10 hours	Wick burner up to 5 hours Automatic burner up to 10 hours	Wick burner up to 5 hours Automatic burner up to 10 hours

Built-in fireplace 2R

Front

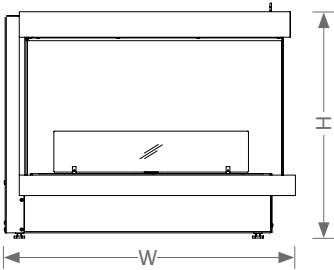

Side

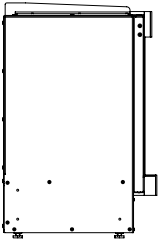

Tunnel

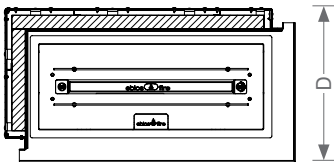

Built-in fireplace U

Front

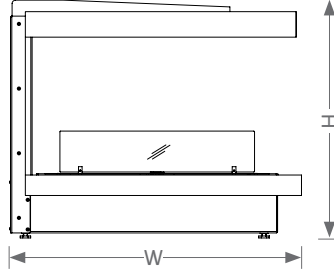

Side

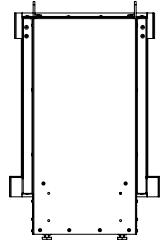

Tunnel

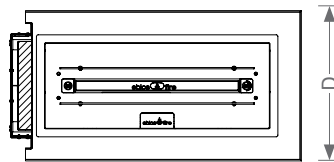

Built-in fireplace C

Front

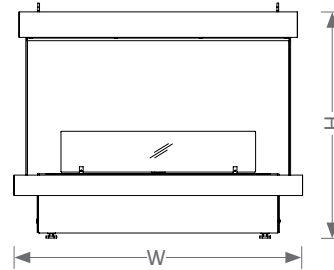

Side

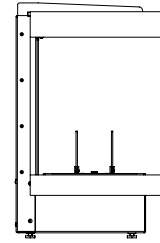

Tunnel

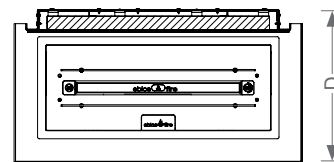

853 / 665 / 450 mm

Steel, black glass,
insulation materials

approx. 93.0 kg

Wick burner or
automatic burner incl. remote control

approx. 500 mm

Wick burner: 2.60 litres
Automatic burner: 1 x 5.0 litre canister*

84 m³

34 m²

Wick burner up to 5 hours
Automatic burner up to 10 hours

855 / 699 / 442 mm

Steel, black glass,
insulation materials

approx. 73.0 kg

Wick burner or
automatic burner incl. remote control

approx. 500 mm

Wick burner: 2.60 litres
Automatic burner: 1 x 5.0 litre canister*

84 m³

34 m²

Wick burner up to 5 hours
Automatic burner up to 10 hours

C 848 / 691 / 451 mm

Steel, black glass,
insulation materials

approx. 73.0 kg

Wick burner or
automatic burner incl. remote control

approx. 500 mm

Wick burner: 2.60 litres
Automatic burner: 1 x 5.0 litre canister*

84 m³

34 m²

Wick burner up to 5 hours
Automatic burner up to 10 hours

Dimensions
W/H/D

Materials

Weight

Burner type

Fire line

Filling capacity

Minimum
room volume

Minimum
room area

Burning
duration

TECHNICAL DETAILS

THE CITY

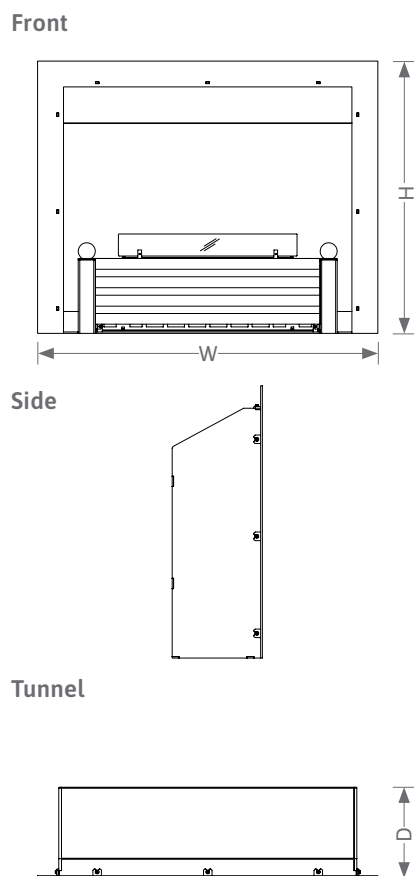

CABINET FIRE

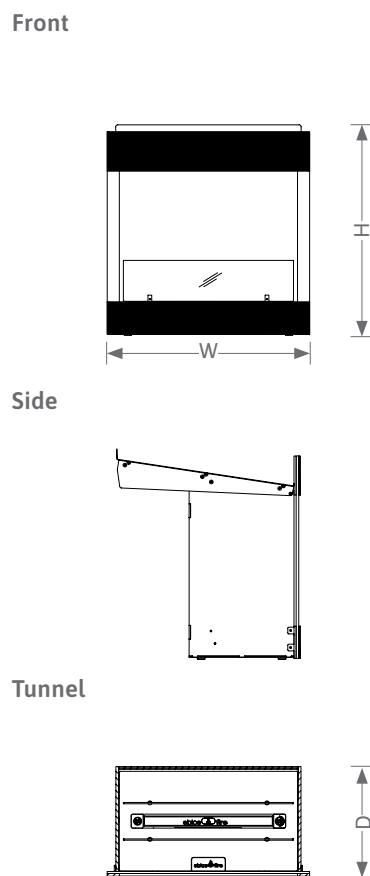

KENSINGTON

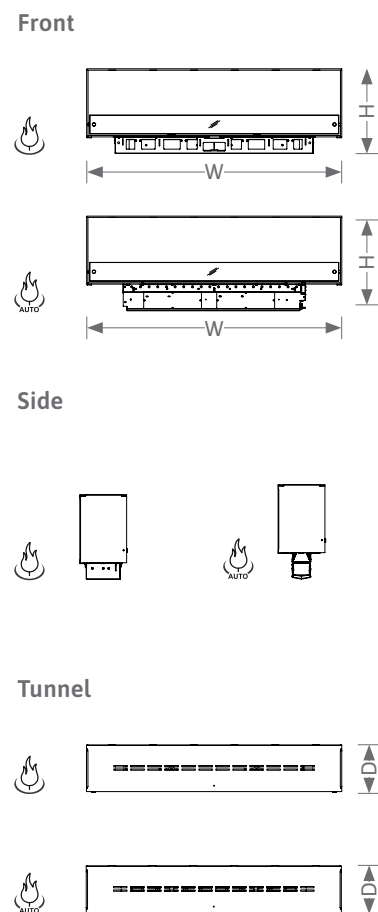

Dimensions W/H/D	1000 / 800 / 265 mm	595 / 618 / 540 mm	min. 800 / 400 / 275 mm
Materials	Steel, chrome, heat-resistant glass ceramic	Brushed stainless steel, aluminium, heat-resistant glass ceramic	Brushed stainless steel, aluminium, heat-resistant glass ceramic
Weight	approx. 40 kg	approx. 40 kg	Depending on size and layout
Burner type	Wick burner EB 500 or automatic burner including remote control	Wick burner EB 450	Wick burner or automatic burner including remote control
Fire line	approx. 500 mm	approx. 450 mm	depending on burner
Filling capacity	Wick burner: 2.60 litres Automatic burner: 9.0 litres	2.60 litres	Wick burner: 2.60 litres Automatic burner: 1 x 5.0 litre canister*
Minimum room volume	84 m ³	60 m ³	84 m ³ per 0.5 m fire line
Minimum room area	34 m ²	24 m ²	34 m ² per 0.5 m fire line
Burning duration	Wick burner: approx. 5 hours Automatic burner: approx. 20 hours	up to 6 hours	depending on burner size

CHELSEA

Front

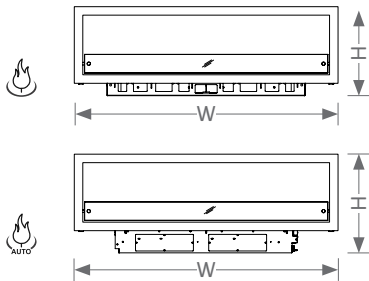

Side

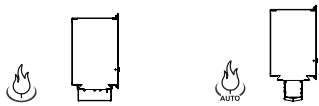

Tunnel

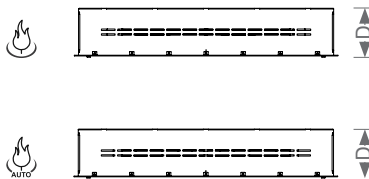

QUADRA INSIDE SL

Front

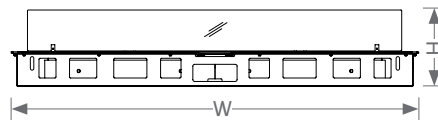

Side



Tunnel



QUADRA INSIDE AUTOMATIC SL

Front

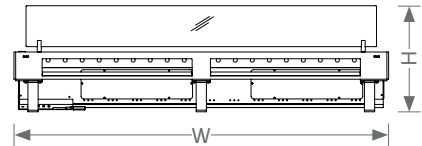

Side

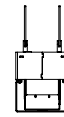

Tunnel



min. 800 / 450 / 280 mm	222 / 698 (1198/1711) / 233 mm	312 / 601 (1101) / 156 mm	Dimensions W/H/D
Brushed stainless steel, aluminium, heat-resistant glass ceramic	Steel, brushed stainless steel, heat-resistant glass ceramic	Steel, brushed stainless steel, glass	Materials
Depending on size and layout	approx. 18.5 / 33.0 / 47.5 kg	approx. 13.0 / 20.0 kg	Weight
Wick burner or automatic burner including remote control	TÜV certified wick burner EB 500	Automatic burner including remote control	Burner type
depending on burner	500 / 2 x 500 / 3 x 500 mm	500 / 1000 mm	Fire line
Wick burner: 2.60 litres Automatic burner: 1 x 5.0 litre canister*	2.60 / 2 x 2.60 / 3 x 2.60 litres	1 x 5 litre canister*	Filling capacity
84 m ³ per 0.5 m fire line	84 m ³ / 132 m ³ / 198 m ³	84 m ³ / 132 m ³	Minimum room volume
34 m ² per 0.5 m fire line	34 m ² / 53 m ² / 80 m ²	34 m ² / 53 m ²	Minimum room area
depending on burner size	up to 5 hours	up to 10 hours (I SL) / 5 hours (II SL)	Burning duration

*not included

TECHNICAL DETAILS

EBIOS ONE 500/500 PLUS

Front

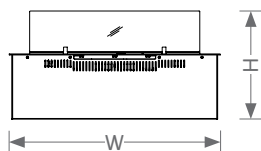

Side



Tunnel

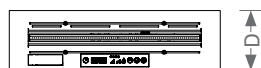

EBIOS ONE 1000

Front

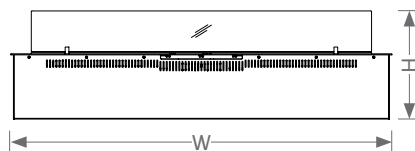

Side

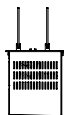

Tunnel

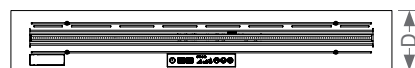

Dimensions W/H/D	620 / 318 / 175 mm	1120 / 318 / 175 mm
Materials	Steel, stainless steel, heat-resistant glass ceramic	Steel, stainless steel, heat-resistant glass ceramic
Weight	approx. 15.0 kg	approx. 28.0 kg
Burner type	Ethanol vaporising burner 3-level flame height	Ethanol vaporising burner 3-level flame height
Fire line	500 mm	1000 mm
Filling capacity	3 litres	6 litres
Minimum room volume	84 m ³	132 m ³
Minimum room Area	34 m ²	53 m ²
Burning duration	up to 6 hours	up to 6 hours

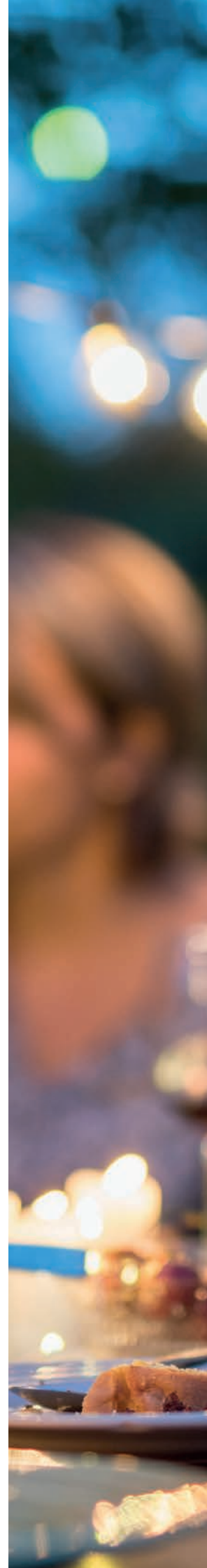

“FASCINATION FOR FIRE
FUELS LOVE OF DETAIL.”

ebios  fire®
burning passion



SPARTHERM Feuerungstechnik GmbH

Maschweg 38 | 49324 Melle

Germany

Tel. +49 5422 9441-0

Fax +49 5422 9441-14

info@ebios-fire.com

www.ebios-fire.com

