

Perfect  
Prime®



aspara™ *Nature* Hydroponic Smart Grower

USER MANUAL



**WARNING: TO REDUCE THE RISK OF FIRE OR ELECTRIC SHOCK, DO NOT REMOVE ANY OF THE APPLIANCE'S COVERS OR PANELS: THERE ARE NO USER-SERVICEABLE PARTS INSIDE! REPAIRS SHOULD BE CARRIED OUT BY AUTHORIZED SERVICE PERSONNEL ONLY.**

## 1.CONTENTENTS

---

1. Contents -----	1
2. Important safeguards -----	2
3. What is aspara™ Nature? -----	3
4. Parts -----	3
5. How to use the appliance -----	5
6. Obtaining Seek Kits -----	11
7. Information on the growing process -----	11
8. Controlling the LED grow light -----	12
9. The aspara™ app -----	12
10.Cleaning and sanitizing -----	13
11. Growing tips -----	16-17
12. Some dos and don'ts -----	17
13. Troubleshooting -----	17
14. Warranties -----	18
15. Customer care -----	19
16. Regulatory notices -----	20
17. Customer Service Inquiries-----	22

## 2. IMPORTANT SAFEGUARDS

---

When using this appliance, basic safety precautions should always be followed. These include the following:

- Read all instructions
- To protect against electrical shock, do not place the cabinet of the appliance, the power cord, the power adaptor or the plug in water or any other liquid.
- Do not place the appliance in a location where it may be played with or misused, such as near unsupervised young children or people with
- reduced physical, sensory or mental capabilities.
- Do not use the appliance if it has a damaged power cord or plug.
- Never let the power cord dangle.
- Do not use unauthorized attachments with the appliance: they may cause fire, electrical shock or physical injury.
- Do not use the appliance if it has been dropped or damaged in anyway.
- Do not look directly at the LED grow light when it is on.
- Do not place anything heavy on top of the appliance or the grow tray.
- Do not place the appliance near a heat source or a naked flame.
- Do not place the appliance on an uneven surface or near the edge of a surface where it may be knocked off.
- Do not move the appliance when it is operating. To move it, always unplug it and empty the water within it first.
- When carrying the appliance, place both your hands underneath its base. **NEVER** carry it by the cylindrical pillar or by the cabinet ceiling (i.e. the part of the appliance where the LED grow light is housed).
- Do not use the appliance outdoors or for a commercial use. It is designed for indoor household use only.
- Always return the appliance to the nearest authorized service facility for examination and/or repair if it has malfunctioned.



### 3. WHAT IS aspara™ Nature?

**aspara™ Nature** is a smart indoor plant grower. Packed with technology, the appliance senses, monitors and manages its growing environment to deliver the best conditions for plant growth. The appliance comes with lots of planting programs and plants for you to choose from and can be controlled by either the built-in control panel or the aspara™ app.

### 4. PARTS

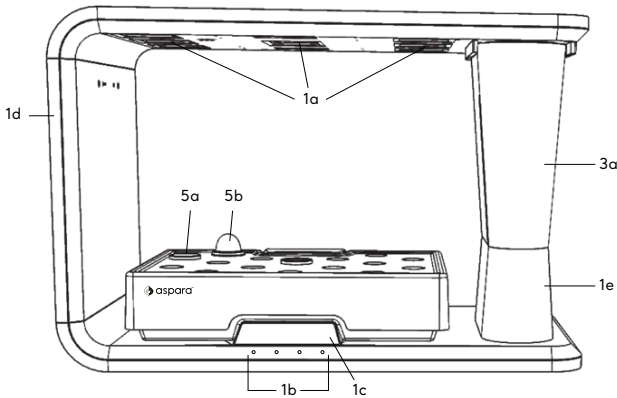

#### Cabinet

- 1a. LED Grow Light
- 1b. Control Panel
- 1c. Display Screen
- 1d. Cabinet
- 1e. Stand
- 1f. Power Socket
- 1g. Docking Station
- 1h. Reset Button

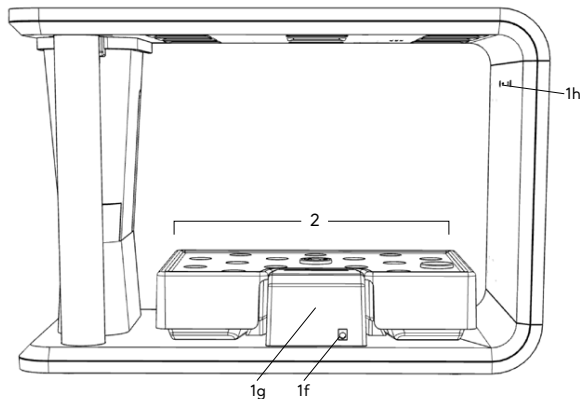

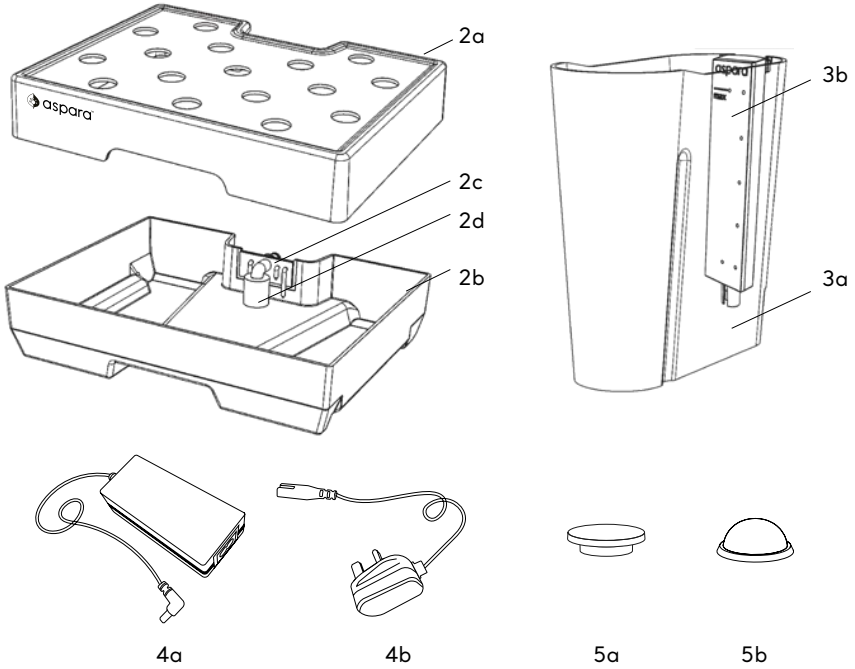

### Grow tray

- 2a. Tray Lid
- 2b. Tray Container
- 2c. Connector
- 2d. Sponge

### Tank assembly

- 3a. Tank
- 3b. Sensing Probe

### Power Cable

- 4a. Power Adaptor
- 4b. Power Cord

### Accessories

- 5a. Grow Hole Covers (x16)
- 5b. Germination Domes (x16)

## 5. HOW TO USE aspara™ Nature

Before first use, wash all parts of the grow tray and the tank assembly. Additionally, wash the grow hole covers and the germination domes.

### 5.1 Powering up and getting the appliance ready to grow

#### 5.1.1 Power up

Assemble the power adaptor and power cord. Plug one end into an electricity socket in your home and the other into the appliance. The appliance will turn on automatically.

#### 5.1.2 Setting the clock and sunrise time

The clock and sunrise time can be set by using either the built-in control panel or the aspara™ app.

- To use the built-in control panel, follow the instructions on the display screen.
- To use the app, download the app and pair it with the appliance. Follow the app's instructions to set the sunrise time. For more information on the app and where to get it, please see Section 9 (The aspara™ app).

**NOTE:** sunset time is automatically set by the appliance based on what you are planting.

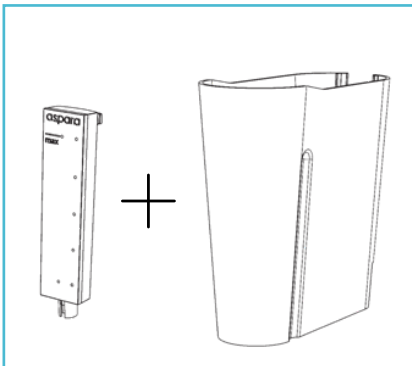

#### 5.1.3 Setting up the tank assembly

- Attach the sensing probe inside the tank

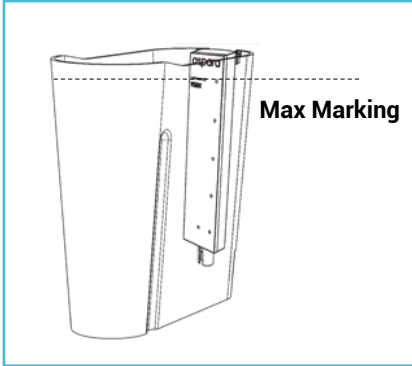

- Fill the tank to the 'max' mark with either tap water or distilled water.

The water should be at room temperature. Do not use well water or softened water as this may interfere with plant development. **NEVER** add water to the grow tray. Water should only ever be added to the tank.

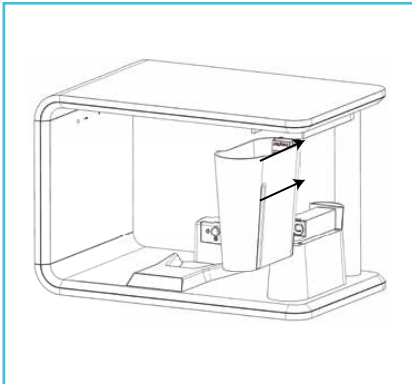

- Insert the tank into the cabinet (it locates on the stand).

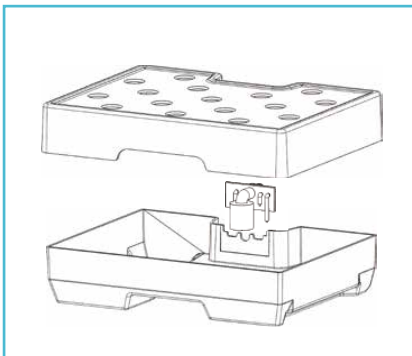

#### 5.1.4 Assembling the grow tray

- Assemble the tray container, tray lid, connector and sponge

## 5.2 Planting

You can grow up to 16 plants in the grow tray. Simply use the same number of seed capsules as the plants you wish to grow. That said, some plants prefer more space than others. Information on this is given in Section 11 (Growing tips).

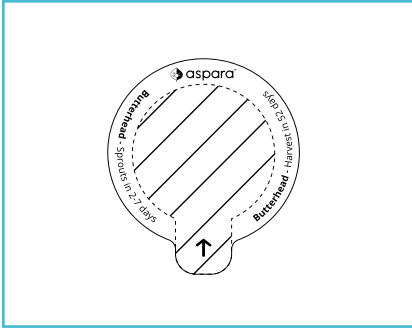

- Tear open the seed capsules according to the cut lines and keep the plant information on the rims.

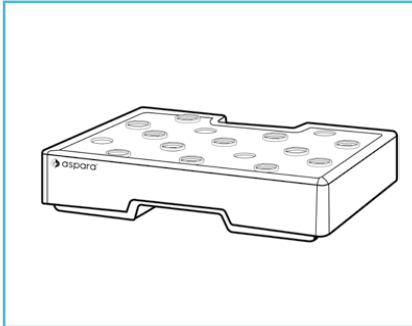

- Insert the seed capsules into the holes in the tray lid. When inserted properly, you should hear a click.

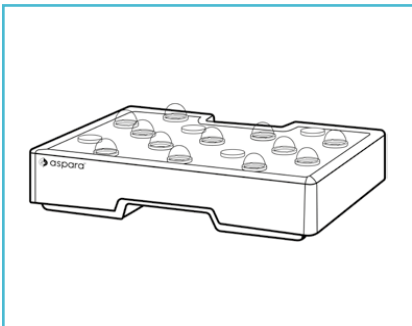

- Cover any empty holes with a grow hole cover.
- Place a germination dome over each seed capsule being used. This keeps the seeds inside moist during germination.



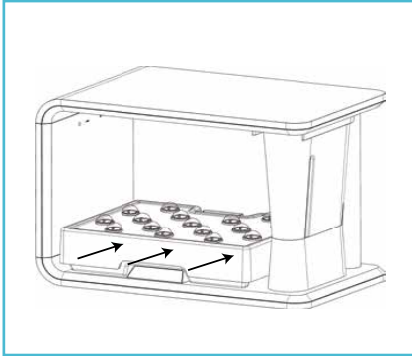

- Slide the grow tray into the cabinet. Make sure that the connector docks with the docking station.

### 5.3 Starting the growing process

The growing process can be started by either using the control panel or the app.

- If using the control panel, match the planting program listed on the control panel menu with the planting program printed on the seed kit.
- If using the app, scan the QR code (Quick Response code) on the seed kit or select your plant in the app.

### 5.4 Caring for your plants during the growing process

During the growing process, there are a few things you need to do to ensure your plants are healthy and strong.

#### 5.4.1 Removing the Germination Domes

When the first two leaves on a plant appear, remove its germination dome. The approximate time to do this is written on each seed capsule. The same information can also be found on the app. Not removing the germination dome at the correct time can inhibit plant growth.

### 5.4.2. Adding water and nutrients

During the growing process, your plants consume water and nutrients. As such, these need to be periodically replenished. The appliance will automatically tell you when to replenish them via the display screen and/or via the app.

Before adding water and/or nutrients, ensure that the appliance is not circulating water. Wait for this to complete if necessary.

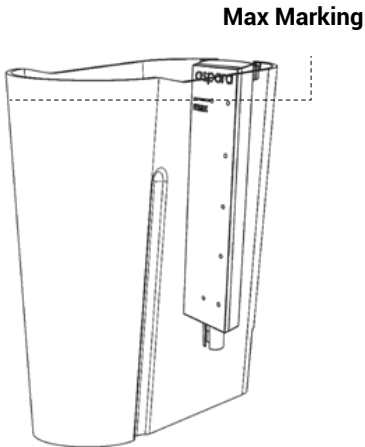

- To add water, pull out the tank and fill it to the 'max' mark with water. As stated above, use tap water or distilled water at room temperature. Next, replace the tank.

- To add nutrients, remove the tank and pour the nutrients into the tank. The display screen will inform you how much is needed. Next replace the tank. (Nutrients can be found in each seed kit).

**ALWAYS** add water and nutrients to the tank.

**NEVER** add them to the grow tray.

## 5.5 Harvesting

If you are growing edible plants, you will want to harvest them. Information on when to do this can be found on each seed capsule and on the aspara™ app.

### 5.5.1 How to harvest

- Slide out the grow tray.
- For harvest, use either scissors, a knife or your hands.
- To continue growing the remaining plants, push the grow tray back into the cabinet and make sure that the connector docks with the docking station.

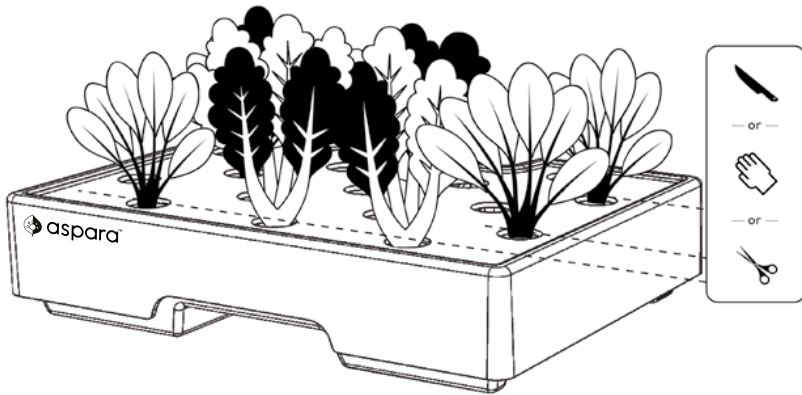

### 5.6 Ending the growing process

Once you have finished growing and there are no more plants to harvest, end planting with either the control panel or the app, the appliance will then be in standby mode. This mode stops the water circulating and the LED grow light from operating.

Remove and throw away any remaining plants and used seed capsules. Refer to Section 10 for cleaning instructions. You can restart planting after cleaning, refer to Section 5.1.3 to restart.



## 6. OBTAINING SEED KITS

---

You'll be pleased to hear that there's a wide range of seed kits available. To find out more, visit [www.perfectprime.com](http://www.perfectprime.com). Here you can learn about what's what and buy more seed kits.

## 7. INFORMATION ON THE GROWING PROCESS

---

As plants journey from seed to harvest, they go through many different stages of development. One stage is germination. During germination, plants start sprouting and their needs are very different to those in later life. Because of these unique needs, the appliance behaves differently during germination: the LED grow light is dim and the water does not circulate very much. This is not a fault! After germination, the LED grow light is bright and the water circulates regularly between the tank and the grow tray. See the table below for more information:

Development stage	Duration	LED grow light	Water movement
Germination	Typically, 3 days	Dim when on	Water stays mostly in the grow tray
Post-germination	Continues until harvest (unless you select a different program or stop the appliance)	Bright when on	Water circulates periodically between the grow tray and the tank Germination and post-germination

Germination and post-germination

If you pair the appliance with the app, the appliance will automatically apply specific program, i.e. the duration, grow light and water movement for the development stages, according to your selected plant.

If you are using the control panel, you will need to extend the germination stage manually for some plants with a longer germination period.

## 8. CONTROLLING THE LED GROW LIGHT

---

You can adjust the brightness of the LED grow light at any time. You can also turn it to white and switch it off. All these functions can be performed using either the control panel or the app. Please note, the LED grow light automatically reverts to its normal plant-growing brightness and color after a set period of time. This occurs to ensure your plants stay healthy.

## 9. THE aspara™ APP

---

If you wish to monitor and control your appliance remotely, get notifications from your smart phone/tablet on when to top up with water and nutrients, and let the appliance provide specific programs for your plant, you need the aspara™ app.

To get the app, head to the App Store (for iOS) or Google play (for Android) and download it. The app is free and is called: aspara™. Once downloaded, you will be provided with instructions to set everything up. Please ensure you have Wi-Fi. You need this to connect your mobile device to the appliance.



aspara™



**NOTE:** You do not need to use the app to grow plants in the appliance. You can use the built-in control panel instead.

## 9.1 Technical information

- The aspara™ app is compatible with the latest version of iOS and Android.
- The appliance uses Wi-Fi based on IEEE 802.11 b/g and n at 2.4 GHz. It connects to networks using WPA2-PSK.

## 9.2 Firmware updates via the app

We occasionally release free feature enhancements and product improvements through firmware updates. The appliance will automatically update when connected to the aspara™ app.

# 10. CLEANING AND SANITIZING

---

The appliance should be cleaned between each growing session and if it has not been used for a while. It should also be sanitized at least once a year and whenever you feel the water is not circulating freely between the tank and the grow tray.

## 10.1 Cleaning

All parts of the appliance that come in contact with the plants and water should be cleaned thoroughly between each growing session. The exception is the growing capsules: these are made of a bio-degradable material and are designed to be thrown away. DO NOT wash the grow tray, tank or any other parts in the dishwasher, they may deform if overheated. We recommend you to do the following:

- Remove the grow tray from the cabinet and dismantle it into its four parts: the tray lid, the tray container, the connector and the sponge. Next dismantle the tank assembly into its two parts: the tank and the sensing probe.
- Wash all parts in clean soapy lukewarm water (i.e. water not higher than 40°C/105°F) and make sure to remove any algae residue. Don't use bleach or harsh cleaners!

- Rinse all parts thoroughly and dry the outsides of the tank and grow tray with a clean soft cloth.
- Assemble and insert the grow tray into the cabinet making sure that the connector docks with the docking station.
- Fix the sensing probe in the tank and fill the tank with clean cold water up to the 'max' mark.
- Slide the tank fully onto the stand.
- Select the clean function on control panel. This starts the water circulating for about an hour between the tank and the grow tray. Once finished, unless you are going to use the appliance immediately, dry all the parts with a soft clean towel. It is particularly important to dry the metal contacts on both the sensing probe and the connector.

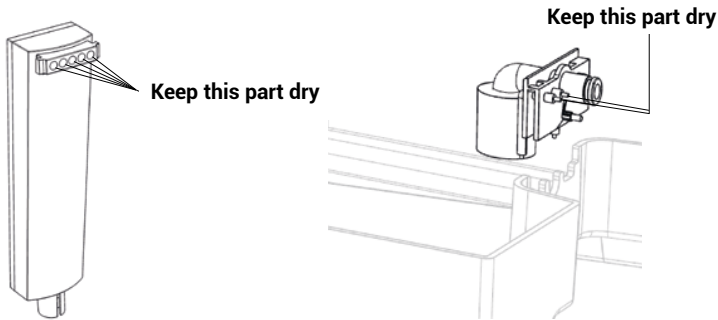

- To clean the cabinet, disconnect it from the electricity supply and wipe it with a damp cloth. Don't clean the power socket and don't allow water to enter the small holes in the cabinet as this may damage the electronics. Don't use bleach or harsh cleaners!
- NEVER immerse the cabinet in water (or any other liquid) or wash it using free-running water.

## 10.2 Sanitizing

We suggest you sanitize the appliance once a year and whenever you feel the water is not circulating freely between the grow tray and the tank. In addition, you may wish to sanitize the appliance if you feel your plants are regularly in bad health. To sanitize the appliance, do the following:

- Make sure the appliance is in standby mode.
- Remove all plants and water from the appliance.
- Add clean water and either citric acid cleaner
- (according to the manufacturer's instructions) or 1 cup of white vinegar to the tank. The tank should be filled up to the 'max' mark.
- Select the clean function on the control panel. This will start the water circulating between the grow tray and the tank. When complete, the water will return to tank. It takes about an hour.
- Next rinse. To do this, first empty both the grow tray and tank then refill the tank with clean water (up to the 'max' mark). Afterwards run the clean function again.
- If you feel that the appliance still has some citric acid cleaner/vinegar in it. Repeat the rinse process.
- Finally, empty the tank and grow tray of water and wipe all parts dry if the appliance is not to be used immediately.



## 11. GROWING TIPS

Below are a couple of growing tips to get you started. There are many more on our website ([www.perfectprime.com](http://www.perfectprime.com)). The same information is available in the app if you scan the QR code on your seed kit.

### 11.1 Number of seed capsules to use in a growing session

To grow healthy and strong plants, we suggest that the maximum number of seed capsules you should use at the same time is as follows:

Plant type	Maximum number of seed capsules
Salad vegetables	8
Herbs	12-16
Tomatoes	4
Radishes	12-16
Flowers	12-16

Recommended maximum number of capsules per plant for each growing session

### 11.2 Thinning out your plants

During the first stages of development you will likely notice more than one plant growing in each seed capsule. This occurs because each seed capsule actually contains more than one seed. To ensure a good harvest, you need to thin your plants out during the growing process to give them space to grow. The best time to do this is when the plants are around 25 mm (2") tall. Simply choose the most healthy-looking plant in each seed capsule and pull out the rest.

### 11.3 Pruning Your Plant

When your herbs, fruiting or flowering plants (e.g. tomato, basil), are growing too tall, reaching a height of 15-20cm (6-8in), you should prune your plants to make sure the plant is shorter than 15cm (6in) and to avoid your plant reaching the LED lights. Regular pruning will help your plant to grow healthier and develop more and better yield.

## 12. SOME DOs AND DON'Ts

---

- **DO** follow the important safeguards listed at the start of this user guide.
- **DO** clean and sanitize the appliance regularly.
- **DO** keep the metal contacts of the connector and the sensing probe dry when not in use.
- **DON'T** remove either the tank or the grow tray when the appliance is circulating water.
- **DON'T** add water or nutrients to the grow tray. Always add them to the tank.
- **DON'T** wash any parts in the dishwasher. The high temperature may disform them.
- **DON'T** leave water in the grow tray or tank when the appliance is not in use.
- **DON'T** invert the cabinet or lay it on its side. This may cause water from the internal tubing leak from the appliance and damage the electronics.
- **DON'T** move the appliance when it is operating or filled with water.
- **DON'T** carry the appliance by the cylindrical pillar or by the cabinet ceiling.

## 13. TROUBLESHOOTING

---

For troubleshooting advice and answers to frequently asked questions, visit [www.perfectprime.com](http://www.perfectprime.com).

## 14. WARRANTIES

---

### 14.1 aspara™ Nature

#### Limited One-Year Warranty

This warranty is available to consumers who purchased aspara™ Nature (from now on called the 'appliance') at retail for personal, family or household use. Except as otherwise required under applicable law, this warranty is not available to retailers or other commercial purchasers or owners.

We warrant that your appliance will be free of defects in materials and workmanship under normal home use for a period of 1 year from the date of original purchase. Please keep your original proof of purchase in order to obtain the warranty benefits.

If your appliance malfunctions or you find any defects within the warranty period, please send or bring it, together with your proof of purchase, to an authorised aspara™ service centre. To find your nearest centre, visit [www.perfectprime.com](http://www.perfectprime.com) (or the appropriate website specific to your country/region).

Your appliance has been manufactured for use specifically in the region of your purchase and with authorized accessories and replacement parts only. This warranty expressly excludes any defects or damages caused by using the appliance not in the region of your purchase, attempted use of your appliance with a converter, as well as use with accessories, replacement parts, repair service or alternations other than those authorized by PerfectPrime. This warranty does not cover any damage caused by accident, misuse, shipment or uses not adhering to this user guide. This warranty excludes all incidental or consequential damages.

## 14.2 aspara™ Seed Kit

### 100% Germination Guaranteed

This limited warranty is available to consumers who purchased an aspara™ Seed Kit (from now on called 'seed kit') at retail for personal, family or household use only.

We warrant that your seed kit will be free of defects in materials and workmanship under normal home use before the best before date printed on the seed kit box label. Please keep the original proof of purchase together with the original seed kit box label in order to obtain the warranty benefits.

If any of the seed capsules contained within the seed kit do not germinate within 3 weeks of planting and yet are within their use by date, please send or bring the defective seed capsule(s) (please do not send the whole seed kit, unless all the capsules are defective) to an authorised aspara™ service centre. To find details of your nearest centre, visit [www.perfectprime.com](http://www.perfectprime.com) (or the website specific to your country/region).

This warranty only covers seed kits whose seed capsules have been used in a growing device that is produced by PerfectPrime and is designed to use them (e.g. aspara™ Nature). It does not cover seed kits that have been improperly used or stored. This warranty does not cover any damage caused by accident, misuse, shipment or uses not adhering to instructions provided by PerfectPrime. This warranty excludes all incidental or consequential damages.

We pledge to replace any defective seed capsules or an entire seed kit if it is faulty. We will replace these items with the same item if possible; if not, we will replace them with a similar item.

## 15. CUSTOMER CARE

---

If you encounter any problems with the operation of your appliance, please visit our website ([www.perfectprime.com](http://www.perfectprime.com)) or check the aspara™ app for support. Please contact us or leave a message on our website if you do not find your answer there. Our contact details are listed below and on our website.

## 16. REGULATORY NOTICES

---

### 16.1 FCC compliance statement

#### North America

United States: Federal Communications Commission [FCC]



#### FCC COMPLIANCE STATEMENT:

This device complies with part 15 of the FCC Rules.

Operation is subject to the following two conditions:

- (1) This device may not cause harmful interference, and
- (2) This device must accept any interference received, including interference that may cause undesired operation.

**INFORMATION TO USER:** This appliance has been tested and found to comply with the limits for a Class B digital device, pursuant to Part 15 of FCC Rules. These limits are designed to provide reasonable protection against harmful interference in a residential installation. This appliance generates, uses, and can radiate radio frequency energy. If not installed and used in accordance with the instructions, it may cause harmful interference to radio communications. However, there is no guarantee that interference will not occur in a particular installation. If this appliance does cause harmful interference to radio or television reception, which can be determined by turning the appliance off and on, the user is encouraged to try and correct the interference by one or more of the following measures:

- Reorient or relocate the receiving antenna. This can be done by moving the appliance to a different location.
- Increase the distance between the appliance and the receiver.
- Connect the appliance to outlet on a circuit different from that to which the receiver is connected.
- Consult the dealer or an experienced radio/TV technician for help.

**WARNING:** The changes or modifications not expressly approved by the party responsible for compliance could void the user's authority to operate the appliance.

## 16.1 Directive 2012/19/EU

European Union

European Union: CE directive



STATEMENT:

Hereby, PerfectPrime, declares that aspara™ Nature (from now on called the 'appliance') is in compliance with the essential requirements and other relevant provisions of Directive 2012/19/EU. The symbol on the appliance or its packaging signifies that this appliance has to be disposed separately from ordinary household wastes at its end of life. Please kindly be aware that this is your responsibility to dispose electronic equipment at recycling centers so as to help conserve natural resources. Each country in the European Union should have its collection centers for electrical and electronic equipment recycling.

For information about your recycling drop off point, please contact your local related electrical and electronic equipment waste management authority or the retailer where you bought the appliance

- Do not dispose of the appliance with household waste.
- Disposal of the packaging and the appliance should be done in accordance with local regulations.

Get aspara™ *Seed Kit* from:

[www.perfectprime.com](http://www.perfectprime.com)



Get aspara™ Mobile Apps from:



## 17. CUSTOMER SERVICE INQUIRIES

Your emails are important to us so we strive to reply all inquiries and emails within **24 hours**. In exceptional cases, we may require more time to respond.  
Thank you for your understanding.

For more information about our products and services, please send us an email:  
**cs@perfectprime.com**

For B2B or project-based application, please send us an **email:**  
**sales@perfectprime.com**

FOR MORE INFORMATION ABOUT PERFECTPRIME PLEASE VISIT OUR ABOUT US PAGE AND FEEL FREE TO BROWSE.



ビデオマニュアルの YouTube チャンネルの QR コードをスキャン  
Scan QR Code for the Youtube channel for video manual



QR コードをスキャンして 1 年間保証のために製品を登録する  
Scan QR Code to register the product for 1 year warranty



製品マニュアルページの QR コードをスキャンする（特定の製品で利用可能な多言語）  
Scan QR Code for the Product Manual page  
(Multi-Language available for certain products)



"MORE THAN IDEAL"

[www.perfectprime.com](http://www.perfectprime.com)

PerfectPrime  
G/F UNIT 3, 61 GLENTHORNE ROAD, LONDON,  
W6 0LJ, UNITED KINGDOM

Copyright © 2019 PerfectPrime. All rights reserved.