

UV LIGHT METER 532

Instruction Manual



**Perfect
Prime**

www.perfectprime.com



CONTENTS

| | |
|---|---------------|
| 1. Safety Information | 2 |
| 2. Introduction | 3 |
| 3. Precautions On Handling | 4 |
| 4. Maintenance | 4 |
| 5. Specifications | 5 |
| 6. Symbol Definition And Button Location | |
| 6.1 LCD Display | 6 |
| 6.2 Name Of Parts & Position | 7 - 10 |
| 7. Characteristics Of Sensor Spectrum Response | 11 |



1. SAFETY INFORMATION

Read the following safety information carefully before attempting to operate or service the meter.

Use the meter only as specified in this manual ; otherwise, the protection provided by the meter may be impaired.

ENVIRONMENT CONDITIONS:

- Altitude up to 2000 meters
- Relatively humidity 70% max.
- Operation Ambient 0 ~ 40°C

EXPLANATION OF SYMBOLS:

-  Comply with EMC.
When servicing, use only specified replacement parts.



2. INTRODUCTION

Thank you for using our UV Light Meter. To ensure that you can get the most from it, we recommend that you read and follow the manual carefully before use. The UV Meter has been designed, manufactured, and delivered under strict quality control criteria. This meter has the following characteristic.

- Easy to use
- Auto power off function
- Measuring range fully covering UVA & UVB
- MAX/MIN function build in
- Large backlight LCD display

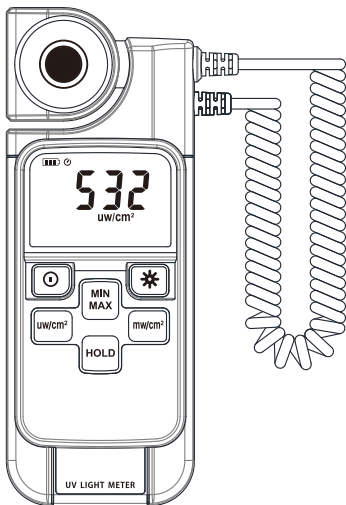



3. PRECAUTIONS ON HANDLING

4. MAINTENANCE

3. PRECAUTIONS ON HANDLING

Operating carefully, and do not drop the meter or hit it with a hard object. Avoid using the meter in a dirty, dusty, or salt-air area or where there are corrosive gases. If dirt or dust adhered to the surface of the light detecting surface, this will decrease the accuracy of the measuring value. To clean the surface, use soft and dry cloth to wipe it clean.

4. MAINTENANCE

ATTENTION!

Repairs or servicing not covered in this manual should only be performed by qualified personal.

CLEANING

Periodically wipe the case with a dry cloth. Do not use abrasives or solvents on this instrument.

Note:

If it is not used for a long time, please store the meter in chamber under 60%RH.



5. SPECIFICATIONS

Measuring range: Low range: 1 to 3999 uw/cm2
High range: 0.01 to 39.99 mw/cm2

Sensitivity Wavelength Region (nm): 260 nm ~ 395 nm

Wavelength for Calibration (nm): 365 nm

Accuracy: $\pm 3\%$ rdg ± 5 dgts

Temperature characteristics: $\pm 0.1\%$ / °C(away from 25°C)

Response time: 0.5 sec

Light detector: UV Photodiode

Over range: "-OL-" display

Power supply: 1.5V type AA battery x2

Power life: Approx. 80 hours

Operation temperature: 0°C ~ 40°C(32°F ~ 104°F)

Operation humidity: 0~80% RH

Storage Temperature: -10 to 50°C (14 to 122°F)

Storage Humidity: 0 to 60% RH

Dimension / Weight: 169(L)×63(W)×37(H)mm (6.7"×2.5"×1.5")

Weight: Approx. 210g

Accessories: Battery, instruction manual, carrying case.



6. SYMBOL DEFINITION AND BUTTON LOCATION

6.1 LCD Display:

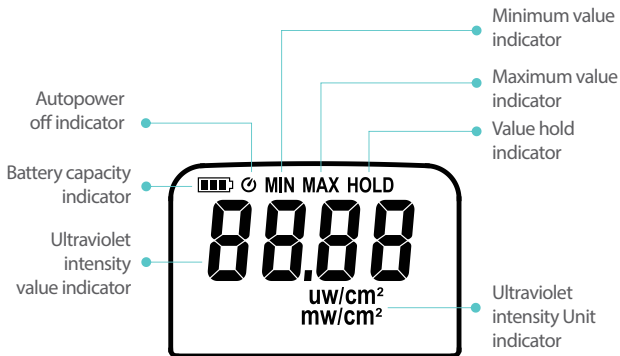

6. SYMBOL DEFINITION AND BUTTON LOCATION

6.2 Name of Parts & Position

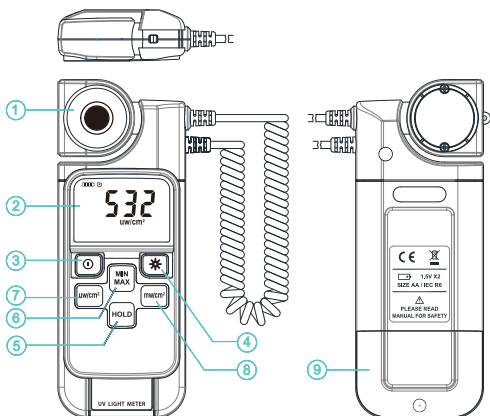

① Light Sensing Probe:

- This probe can be fixed on the meter parallel or perpendicular to the LCD surface.

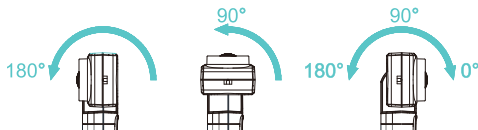

6. SYMBOL DEFINITION AND BUTTON LOCATION

- Or it may be detached from the unit to fit the measuring requirement.

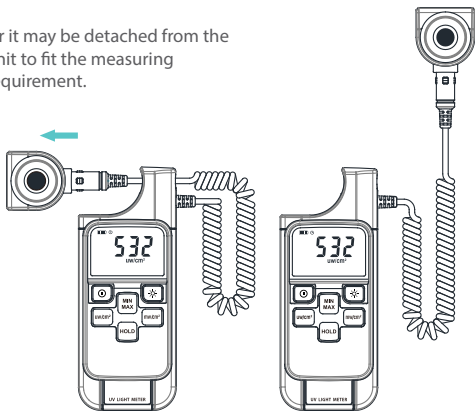



② LCD display:

6 1/2" large size back light LCD display.



6. SYMBOL DEFINITION AND BUTTON LOCATION

3 **Power button:**

Push this button to turn on the meter. Push and hold this button for 3 seconds to turn it off. The unit will automatically turn itself off after 30 minutes if there is no key operation. To disable the automatic power off function, turn the meter off, push and keep holding "" button, then push power button to turn on. The "" will disappear from the LCD to confirm this operation.

4 **Backlight (Power) button:**

Push this button to turn on and off the LCD backlight. The backlight will be automatically off after 30 seconds to save battery power.

5 **HOLD button:**

The user may hold the present reading and keep it on the LCD display by pressing the  button. To release the data held operation, user may press the button again.

6 **Max Min button:**

Push this button to set the meter working under MAX/MIN mode. By pushing this button, the user may swap the LCD reading among maximum, minimum and current reading. Push and hold this key for 3 seconds to exit MAX/MIN mode.

6. SYMBOL DEFINITION AND BUTTON LOCATION

7 **uw/cm² selector button:**

To switch the measuring range to lower range with unit uw/cm²

8 **mw/cm² selector button:**

To switch the measuring range to higher range with unit mw/cm²

9 **Battery cabinet cover:**

When battery capacity segment is less than one, the user should replace the battery. The battery cabinet cover can be opened with a Philips screw driver and two AA type batteries should be replaced.

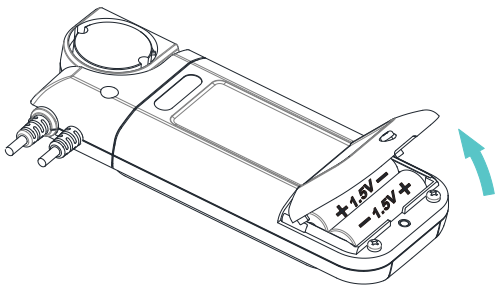



7. CHARACTERISTICS OF SENSOR SPECTRUM RESPONSE

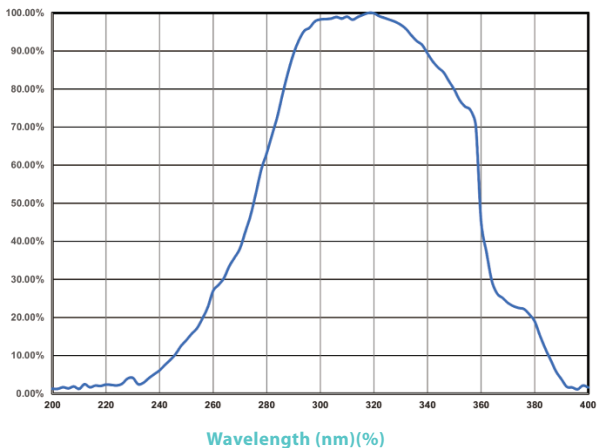

CUSTOMER SERVICE INQUIRIES

Your emails are important to us so we strive to reply all inquiries and emails within **24 hours**. In exceptional cases, we may require more time to respond.

Thank you for your understanding.

For more information about our products and services, please send us an email:

cs@perfectprime.com

For B2B or project-based application, please send an email:

sales@perfectprime.com

FOR MORE INFORMATION ABOUT PERFECTPRIME PLEASE VISIT OUR ABOUT US PAGE AND FEEL FREE TO BROWSE.



Scan QR Code for the Youtube channel for video manual



Scan QR Code for the Product Manual page (Multi-Language available for certain products)



Scan QR Code to register the product for 1 year warranty



Tyche Smart Limited
cs@perfectprime.com
2nd Floor, 107 Charterhouse Street,
EC1M 6HW, London,
England UNITED KINGDOM

+44 203 7695377

Retailer

Email

Address

Telephone