

LIGHT METER 530

Instruction Manual



**Perfect
Prime**

www.perfectprime.com



CONTENTS

1. Safety Information	2
2. Introduction	3
3. Precautions On Handling	4
4. Maintenance	4
5. Specifications	5
6. Symbol Definition And Button Location	
6.1 LCD Display	6
6.2 Name Of Parts & Position	7 - 11
7. Characteristics Of Sensor Spectrum Response	12



1. SAFETY INFORMATION

Read the following safety information carefully before attempting to operate or service the meter.

Use the meter only as specified in this manual ; otherwise, the protection provided by the meter may be impaired.

ENVIRONMENT CONDITIONS:

- Altitude up to 2000 meters
- Relatively humidity 90% max.
- Operation Ambient 0 ~ 40°C

EXPLANATION OF SYMBOLS:

-  Comply with EMC.
When servicing, use only specified replacement parts.



2. INTRODUCTION

Thank you for using our Light Meter. To ensure that you can get the most from it, we recommend that you read and follow the manual carefully before use. The Light Meter has been designed, manufactured, and delivered under strict quality control criteria by a factory certified. This meter has the following characteristic.

- Easy to use
- Automatic zero
- Automatic ranging
- MAX/MIN function
- Large backlight LCD display

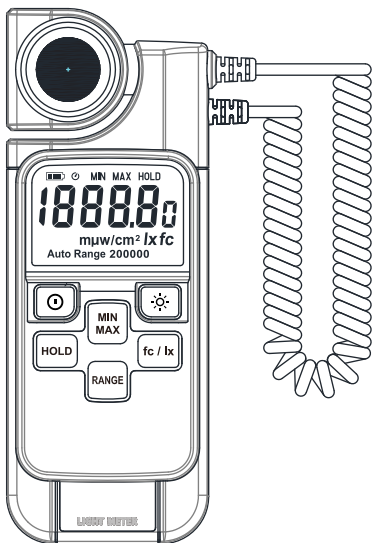



3. PRECAUTIONS ON HANDLING

4. MAINTENANCE

3. PRECAUTIONS ON HANDLING

Operating carefully, and do not drop the meter or hit it with a hard object. Avoid using the meter in a dirty, dusty, or salt-air area or where there are corrosive gases. If dirt or dust adhered to the surface of the detecting light, will decrease accuracy of the measuring value to clean the surface by wiping with a soft and dry cloth.

4. MAINTENANCE

ATTENTION!

Repairs or servicing not covered in this manual should only be performed by qualified personal.

CLEANING

Periodically wipe the case with a dry cloth. Do not use abrasives or solvents on this instrument.

Note:

If it is not used for a long time, please store the meter in chamber under 60%RH.



5. SPECIFICATIONS

Measuring level range	0.0 to 199.9/1999/19990/199900 lx 0.0 to 19.9/199.9/1999/19990fc Automatic or manual selection of range
Resolution:	0.1 ~ 100 lx, 0.1 ~ 10 fc
Accuracy:	±3% (Calibrated to standard incandescent lamp 2856°K) 8% other visible light source
Angle deviation from cosine characteristics:	10° ± 1% 30° ± 2% 60° ± 5% 80° ± 20%
Temperature characteristics:	±0.1% / °C(25°C)
Response time:	0.5 sec
Light detector:	SI Photodiode
Over range:	"-OL-" display
Power supply:	1.5V type AA battery x2
Power life:	Approx. 80 hours
Operation temperature:	0°C ~ 40°C(32°F ~ 104°F)
Operation humidity	0~80% RH
Storage Temperature:	-10 to 50°C (14 to 122°F)
Storage Humidity:	0 to 60% RH
Dimension / Weight:	169(L)×63(W)×37(H)mm (6.7"×2.5"×1.5")
Weight:	Approx. 185g
Accessories:	Battery, instruction manual, carrying case.

[Note] 1fc = 10.76lx

6. SYMBOL DEFINITION AND BUTTON LOCATION

6.1 LCD Display:

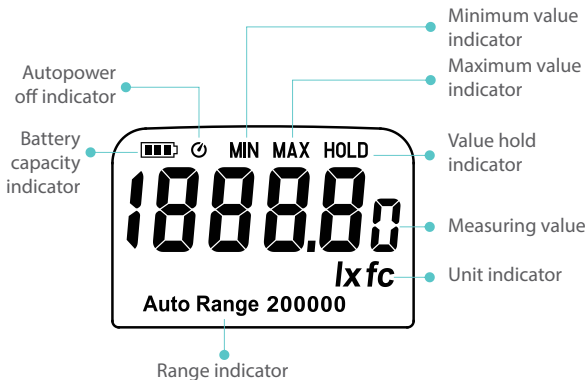

6. SYMBOL DEFINITION AND BUTTON LOCATION

6.2 Name of Parts & Position

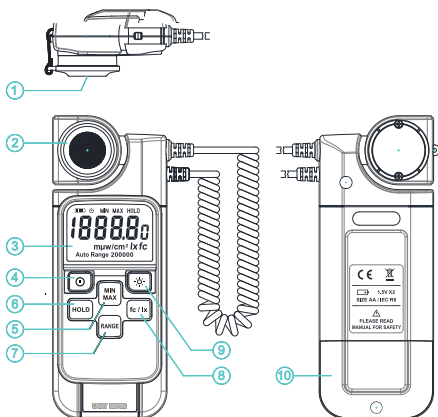

* Operation:

Press the power button to turn on the power. Notice that covering the light-detecting surface with the cap. "CAP-" will auto-appear on the LCD display. After "CAL-" appears, the meter enters the automatic zero adjustment. When automatic zero adjustment is completed, "CAL-" disappears and "0.0" appears. After confirming the "0.0" display, remove the cap to start measuring. After the measurement has been completed, press the power button again to turn off the power, and cover the light-detecting surface with the cap for protecting against stray light.



6. SYMBOL DEFINITION AND BUTTON LOCATION

Note:

If "ERR1" appears, check the cap to make sure it is on properly

① Sensor Cap :

This part is to protect the sensor from scratching and create complete dark environment for the meter to perform dark current calibration. During power on process, this cover should be set properly on the sensor otherwise an error message will be shown on the LCD.

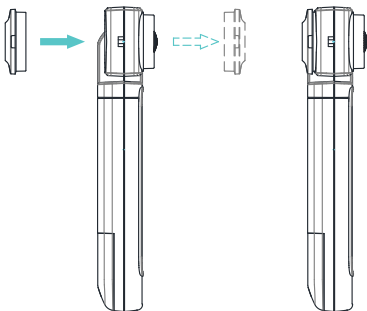

② Light Sensing Probe:

- This probe can be rotated various angles to the LCD surface to suit the measuring requirement.

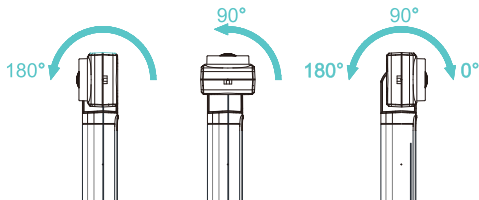

6. SYMBOL DEFINITION AND BUTTON LOCATION

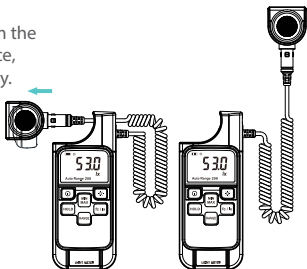

- It can be also detached from the meter to measure in distance, which creates more flexibility.



3 LCD display:



6 1/2" large size back light LCD display.

4 Power button:

Press  button to turn on the meter and it will automatically turn itself off 30 minutes after its last key operation. The user may disable this automatic power off function by pressing and holding "HOLD" button while powering on. The "  " symbol will disappear to confirm this operation.

Press  button again to turn the meter off.

5 Max Min button:

Press  button to set the meter working under MAX/MIN mode. By pressing  button, the user may swap the LCD reading among maximum, minimum and current reading. Press and hold  button for 3 seconds to exit Max/Min mode.



6. SYMBOL DEFINITION AND BUTTON LOCATION

⑥ HOLD button:

The user may hold the present reading and keep it on the LCD display by pressing the  button. To release the held data operation, press the button again.

⑦ Range selector button:

The user may use the  button to select the preferred measuring range or automatically selected by the meter.

The available ranges are:

AUTO, 200, 2000, 20000, 200000 lx

AUTO, 20, 200, 2000, 20000 fc

⑧ Fc/lx selector button:

Press  button to switch the measuring unit between Foot Candle and Lux.

⑨ Backlight button:

Press  button to turn on the LCD back light and it will be automatically off after 30 seconds.



6. SYMBOL DEFINITION AND BUTTON LOCATION

10 Battery cabinet cover:

When battery capacity segment is less than one, the user should replace the battery. The battery cabinet cover can be opened with a Philips screw driver and two AA type batteries should be installed.

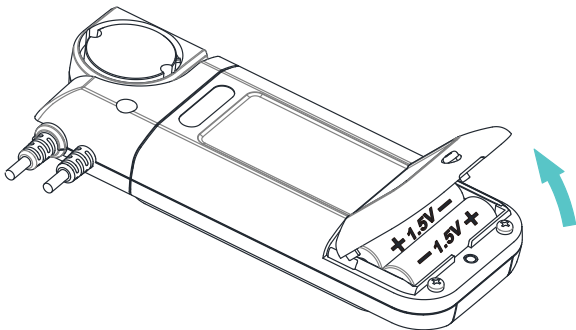

7. CHARACTERISTICS OF SENSOR SPECTRUM RESPONSE

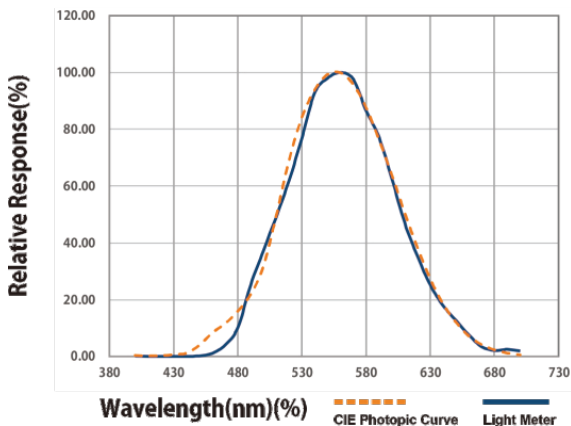

CUSTOMER SERVICE INQUIRIES

Your emails are important to us so we strive to reply all inquiries and emails within **24 hours**. In exceptional cases, we may require more time to respond.

Thank you for your understanding.

For more information about our products and services, please send us an email:

cs@perfectprime.com

For B2B or project-based application, please send an email:

sales@perfectprime.com

FOR MORE INFORMATION ABOUT PERFECTPRIME PLEASE VISIT OUR ABOUT US PAGE AND FEEL FREE TO BROWSE.



Scan QR Code for the Youtube channel for video manual



Scan QR Code for the Product Manual page (Multi-Language available for certain products)



Scan QR Code to register the product for 1 year warranty



Tyche Smart Limited
cs@perfectprime.com
2nd Floor, 107 Charterhouse Street,
EC1M 6HW, London,
England UNITED KINGDOM

+44 203 7695377

Retailer

Email

Address

Telephone