

Thank you for purchasing our
**Cresco 20SW Fertilizer and
Salt Spreader**



**We're delighted to have you as a customer
and are here to help! First off, let's get your
product assembled!**

Table of Contents:

- 1:** Spare Parts
- 2:** Slide System Explanation
- 3-7:** Assembling your Cresco 20SW
- 8-10:** Slide System Explanation
- 11-14:** How to Use the Cresco 20SW
- 15:** Application guide for fertilisers
- 16:** Warranty

Scan for video aseembly:



Spare Parts

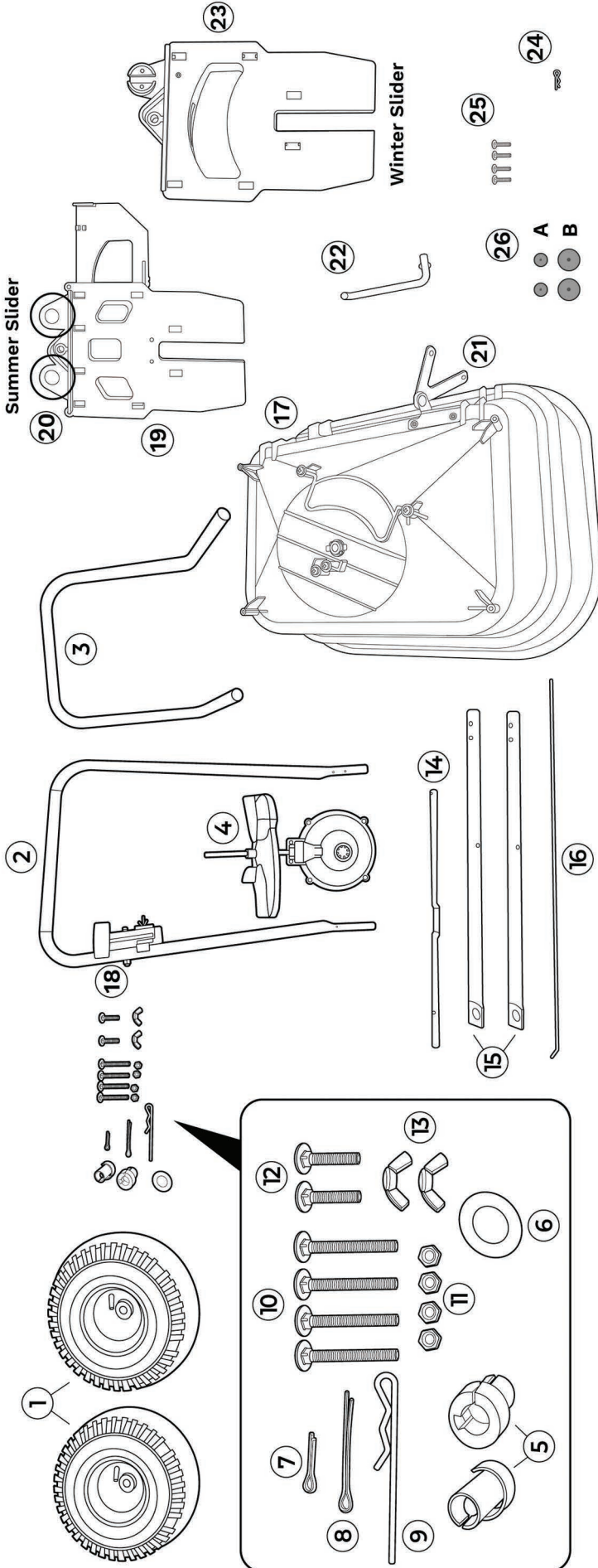

Empty all contents of the box onto a flat surface and count parts to make sure all are there.

CRESCO 20 PARTS LIST:

1. Pneumatic Wheel (X2)
2. Handle Bar
3. Stand
4. Gear box and Impellor
5. Axle bearing (X2)

6. Wheel Washer
7. Small Cotter pin
8. Large Cotter pin
9. Agitator
10. M6x60 Bolts (X4)
11. M6 lock nuts (X4)
12. M6 X35 Bolts
13. M6 Wing Nut (X2)
14. Axle
15. Lower Frame (X2)
16. Control Rod
17. Hopper Body
18. Control Lever
19. Summer Slider

20. Adjuster
21. Pivot Bracket
22. Lower Linkage
23. Winter Slider
24. R-pin Small
25. 4x Screws
26. 4x Washers

Scan to view and purchase spare parts:



Slide System **Explanation**

Your Cresco spreader comes with two different application sliders.
One is for winter and the other is for summer!



Winter Slider



Summer Slider

Please locate and choose your slider.

Assembling your **Cresco 20**

ASSEMBLING THE SLIDER SYSTEM, LOWER FRAME AND STAND:

Video instructions available on front page:

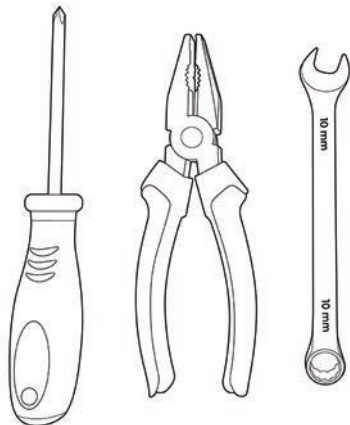

You will need a phillips head screwdriver, one pair of plyers/grips and an M6 metric spanner.

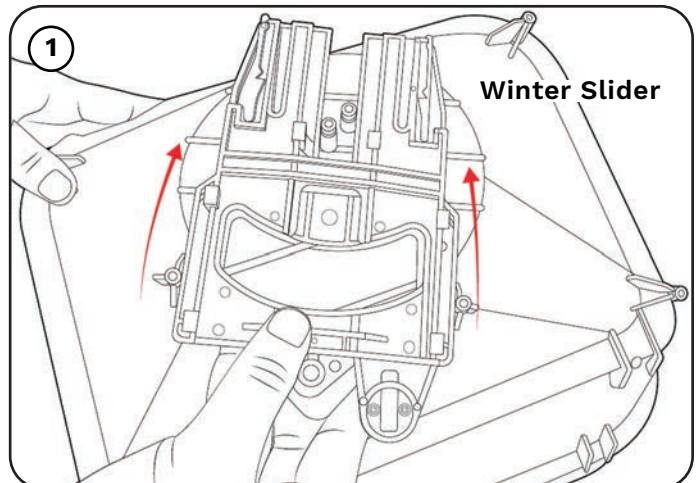

If you are using the spreader for winter, slide the winter application into position as shown above.

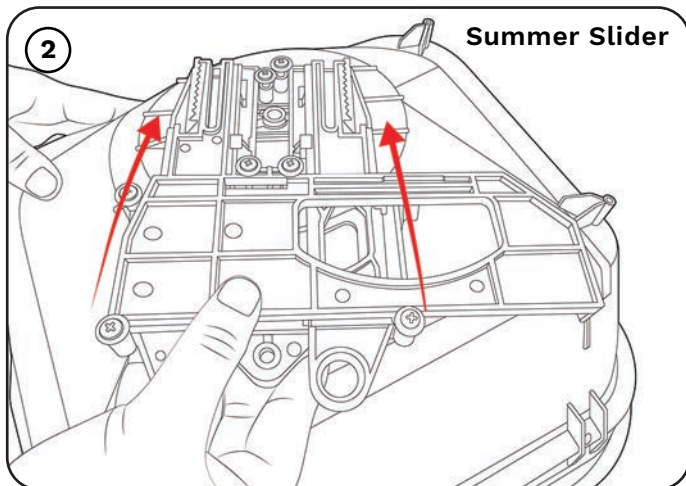

If you are using the spreader for fertiliser or seed, slide the summer application into position as shown above.

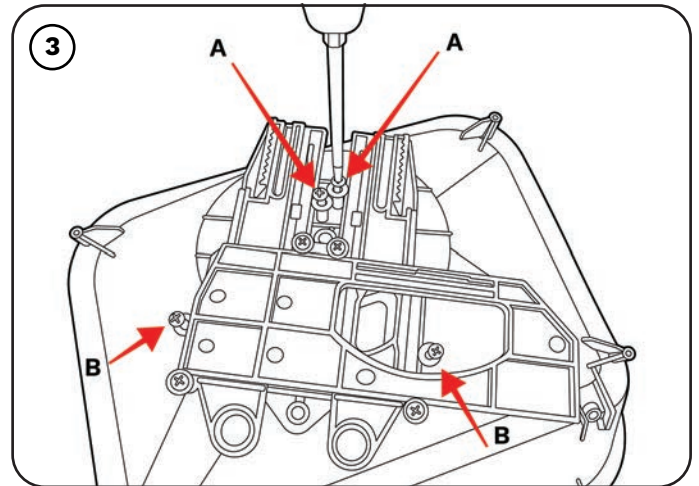

Locate & tighten the 4 screws (25) & washers (26) to fix the required slider (winter or summer) into position. Make sure the screws are not overly tight and the slider can slide backward and forward.

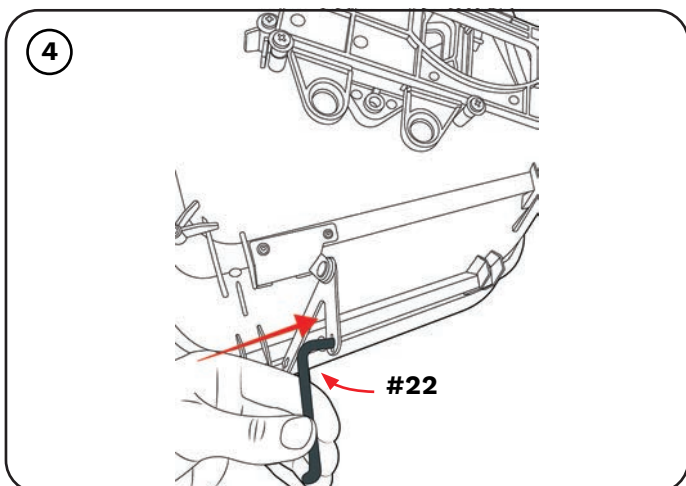

Locate the lower linkage (22) and place it through the pivot bracket (21).

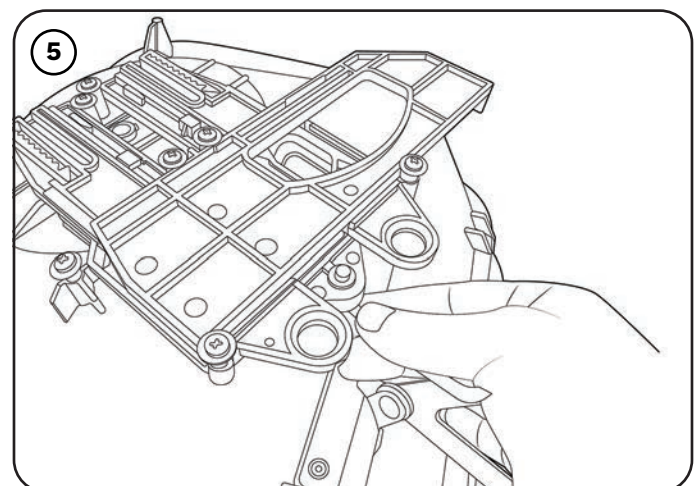

Push the free end of the lower linkage (22) through the centre hole of the chosen slider.

Video Instructions - URL:
<https://crescospreaders.com/spreads-estate/>

Assembling your **Cresco 20**

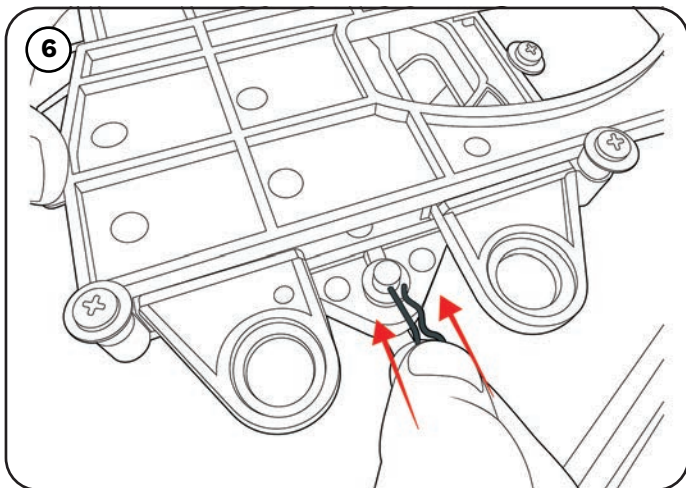

Secure the lower linkage (22) in place using the R pin small (24) as shown.

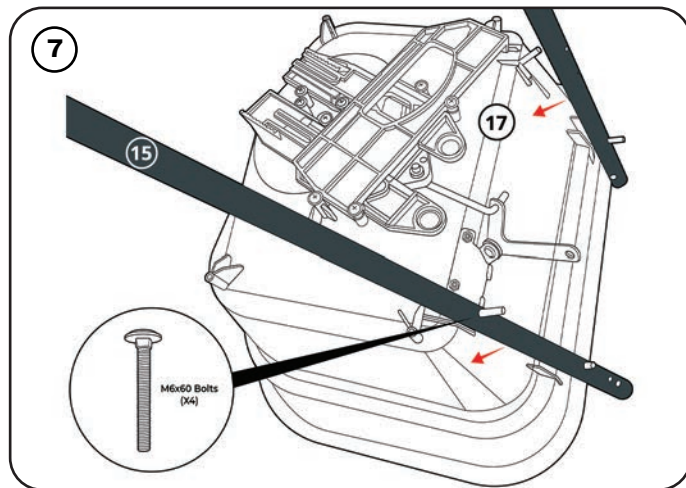

Take the two lower frames (15) and attach them to the hopper body (17) using the M6x60 bolts (10). **SEE NOTE.**

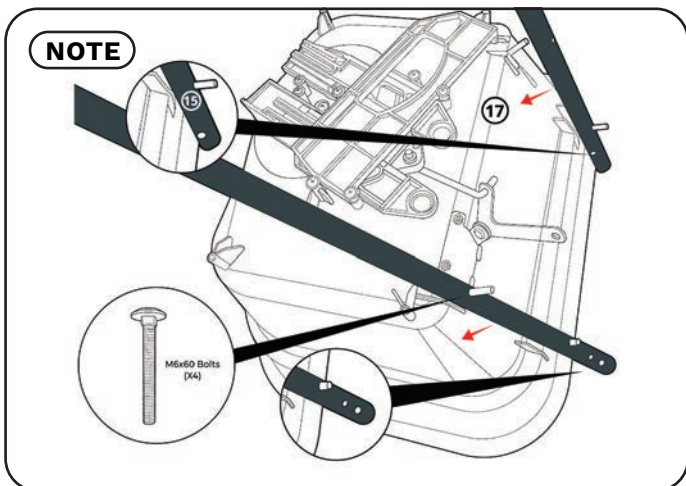

When placing the legs on the hopper, make sure the two holes on the side of the lower frame (Item 15) are on the outside. There should be one hole on the inside.

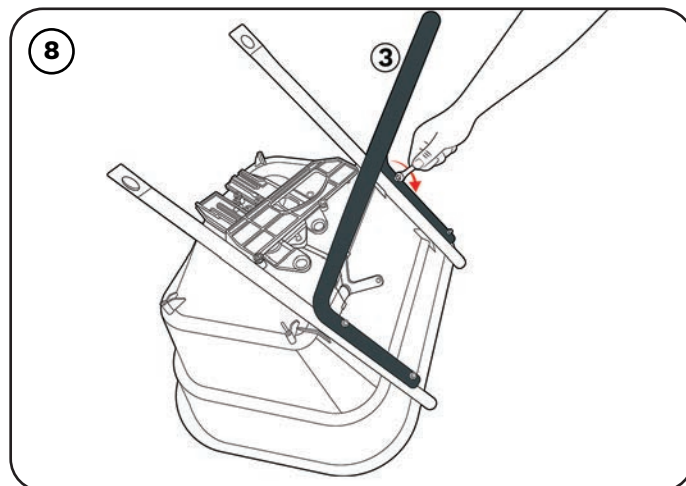

Take the stand (item 3) and place it into the protruding M6x60 bolts (x4) (item 10). Tighten with the M6 lock nuts (x4) (Item 11).

ASSEMBLING THE WHEELS:

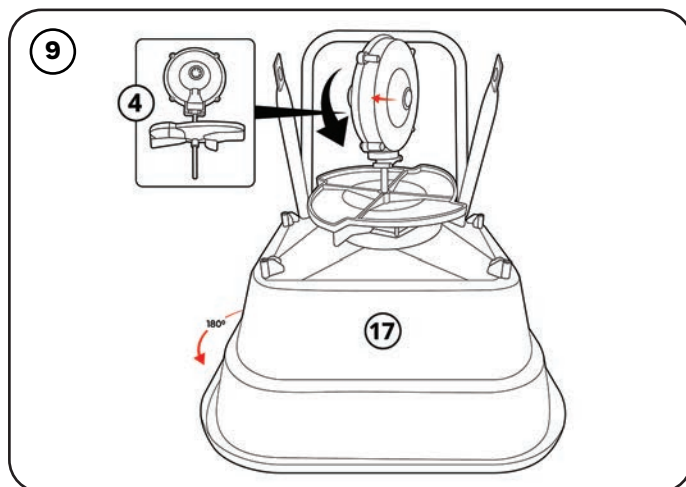

Rotate the hopper body (17) to the position shown. Place the gear box and impeller (4) in the centre hole of the hopper body (17), let it rest there. **Make sure the arrow on the gearbox faces forwards. The arrow should point away from the stand (2).**

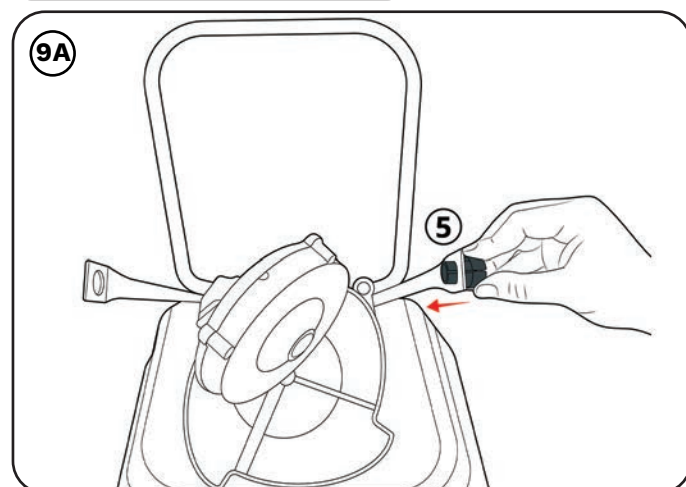

Place one axle bearing (Item 5) into the hole shown at the bottom of the lower frame (15).

Assembling your **Cresco 20**

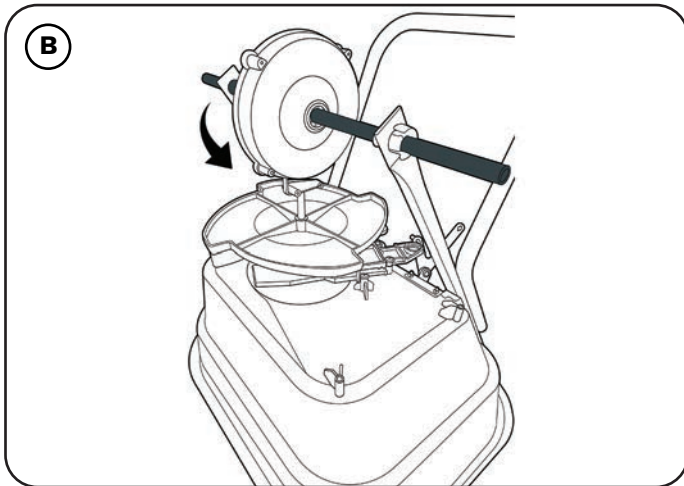

Feed the axle (14) through the hole without the axle bearing (Item 5), push it through the hole in the centre of the gearbox and through the hole (Item 5) on the other side.

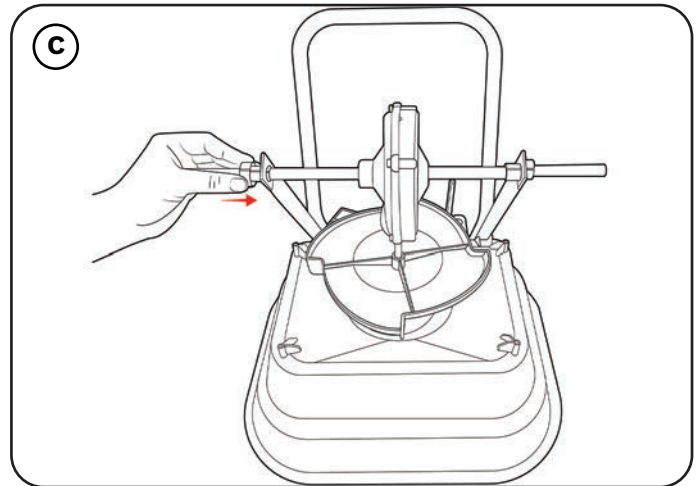

Push the other axle bearing (Item 5) into position.

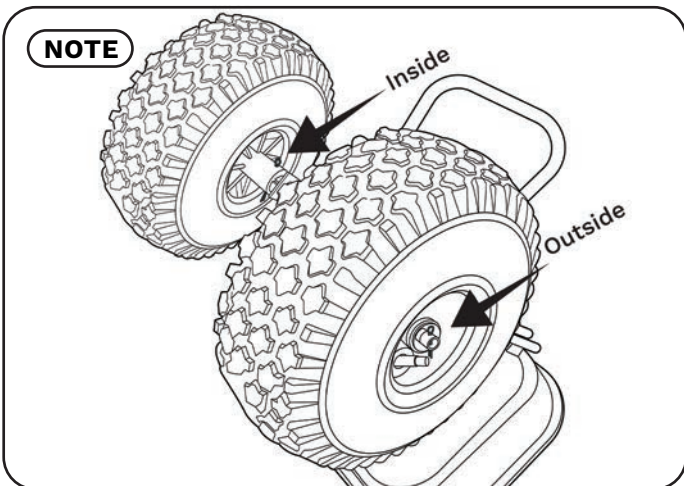

Note: The axle and gearbox are now in position. There are two holes on the axle. One hole is closer to the middle of the axle and the other hole is closer to the edge of the axle. When assembling the wheels: one wheel will be pinned on the inside of the wheel and the other will be pinned on the outside of the wheel.

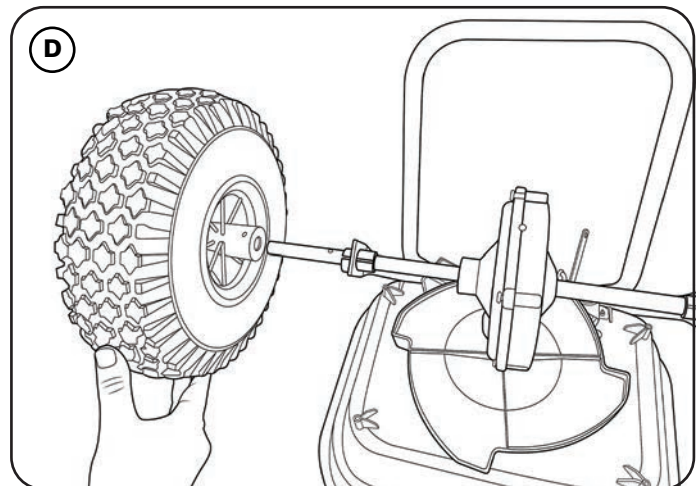

Take one of the pneumatic wheels. Push the wheel through the axle. Make sure the valve is located on the outside.

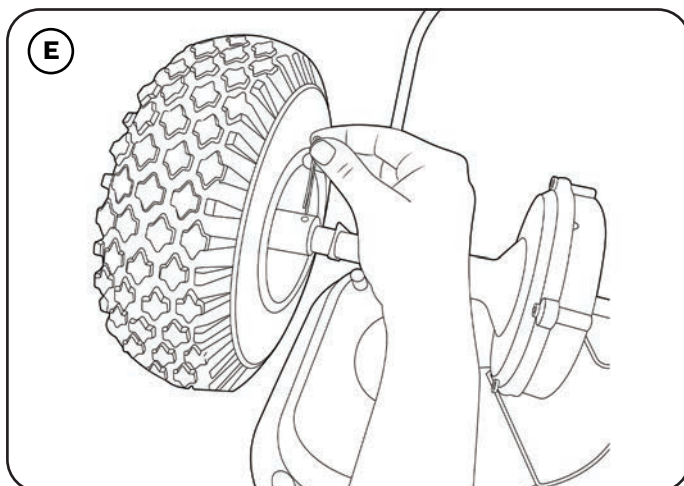

Take the long cotter pin (8) and place it through the hole on the axle on the inside of the wheel.

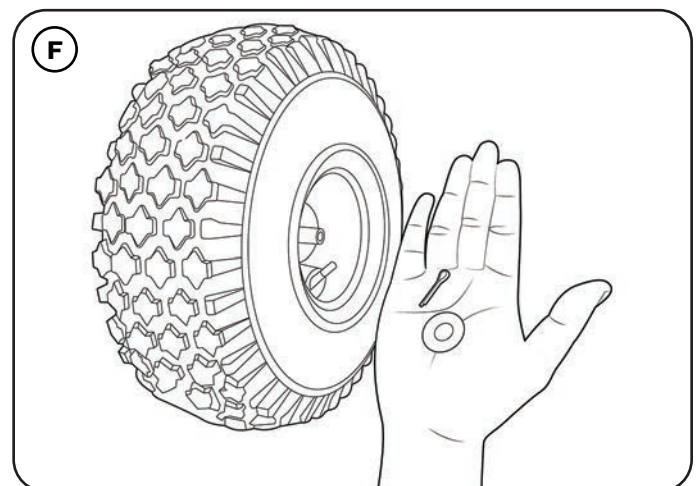

Attach the other pneumatic wheel. Take the small cotter pin (item 7) and the wheel washer (6). Place the wheel washer over the axle and slide the cotter pin (item 7) into the holes to fix the second wheel. It should now look like the image in the note section.

Assembling your **Cresco 20**

ASSEMBLING THE HANDLE BAR AND CONTROL ROD:

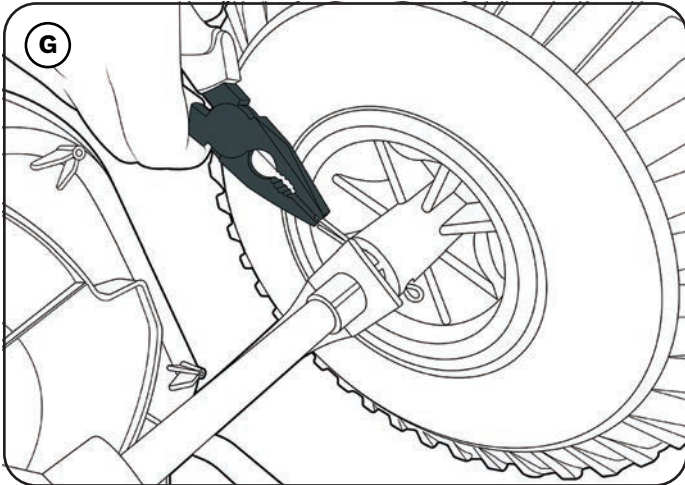

Use the pliers to split the cotter pins on both sides.

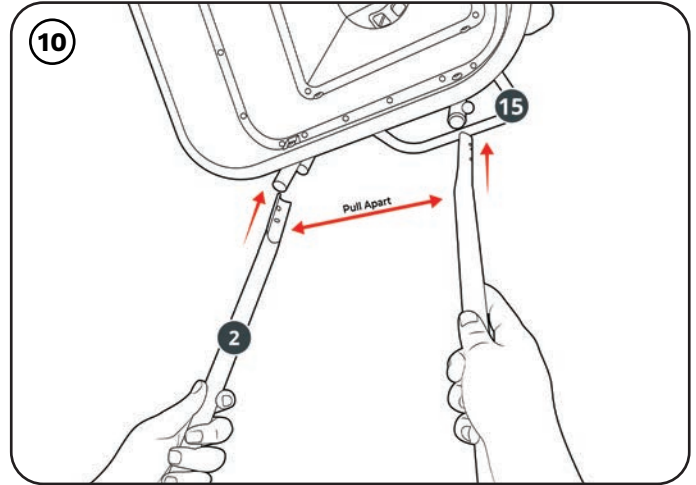

Flip the spreader onto its wheels and ensure they work correctly. Align the holes at the bottom of the handle bar (item 2) with the holes at the top of the lower frame (item 15). You may need to pull the ends apart slightly to place in position.

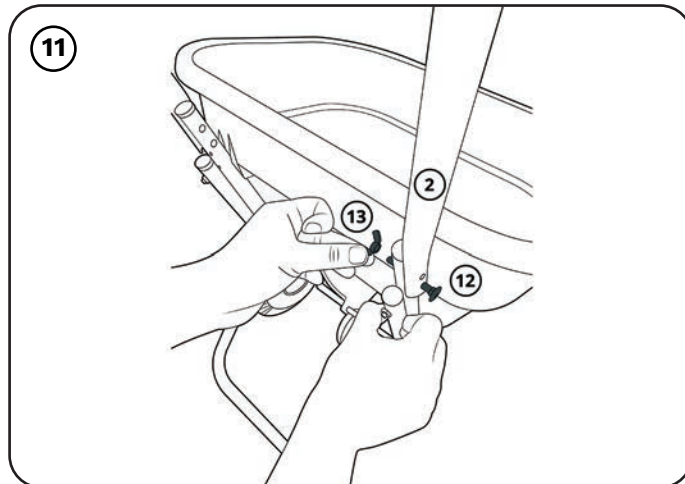

Thread the M6x35 bolt (12) through the hole of the handle bar (item 2) and lower frame (item 15). Use the M6 wingnut (13) to tighten. Repeat on both sides.

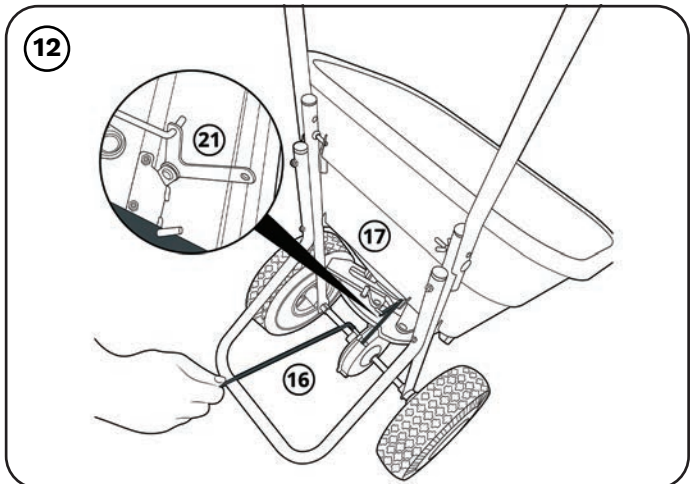

Protruding from the back of the hopper body (item 17) is a V-shaped metal (Item 21-pivot bracket). Clip the L shaped end of the control rod (item 16) into the hole on the V-shaped metal.

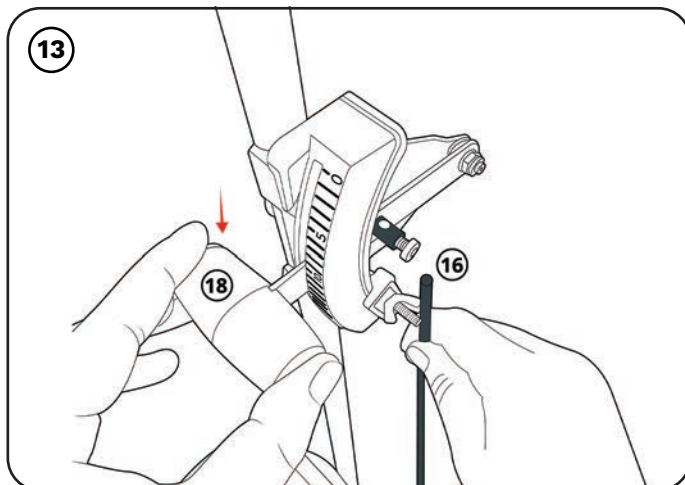

Feed the other end of the control rod (item 16) through the hole at the back of the control lever (Item 18). Make sure you push the lever all the way to the bottom.

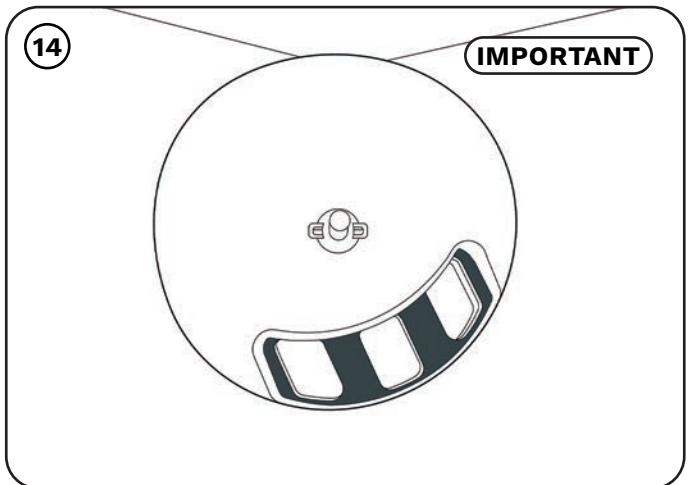

Before tightening the control rod. Make sure the application holes in the hopper are fully open and the control lever is set at 20.

Assembling your **Cresco 20**

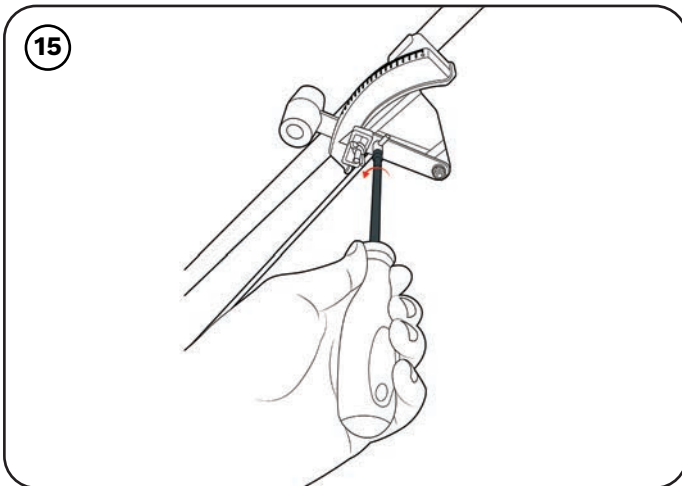

Tighten the control rod.

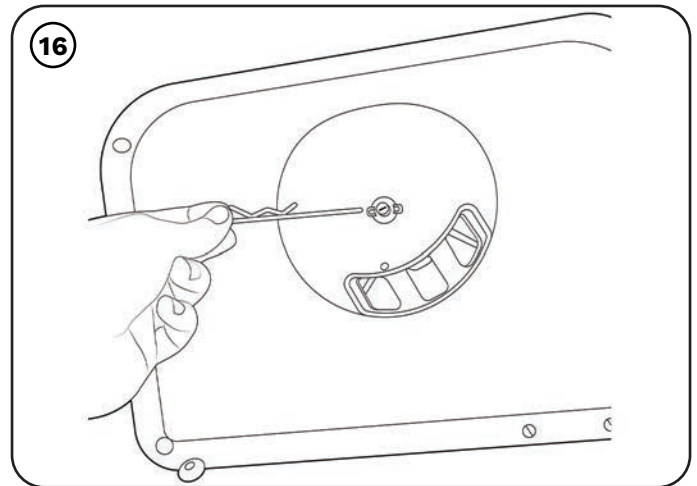

Affix the agitator pin (item 9) through the impellor shaft inside the hopper.

If at any point you become stuck, please visit our Youtube channel for video instructions and tips.

Slide System **Explanation**

Winter

For spread width 6 meters.



Pavement setting (2 meters).



Ice Melts



Summer

The summer slide system comes with 20 different settings and a border control. This slider provides control over the accuracy of your spreading.

Large/Heavy Materials

Small/Light Materials

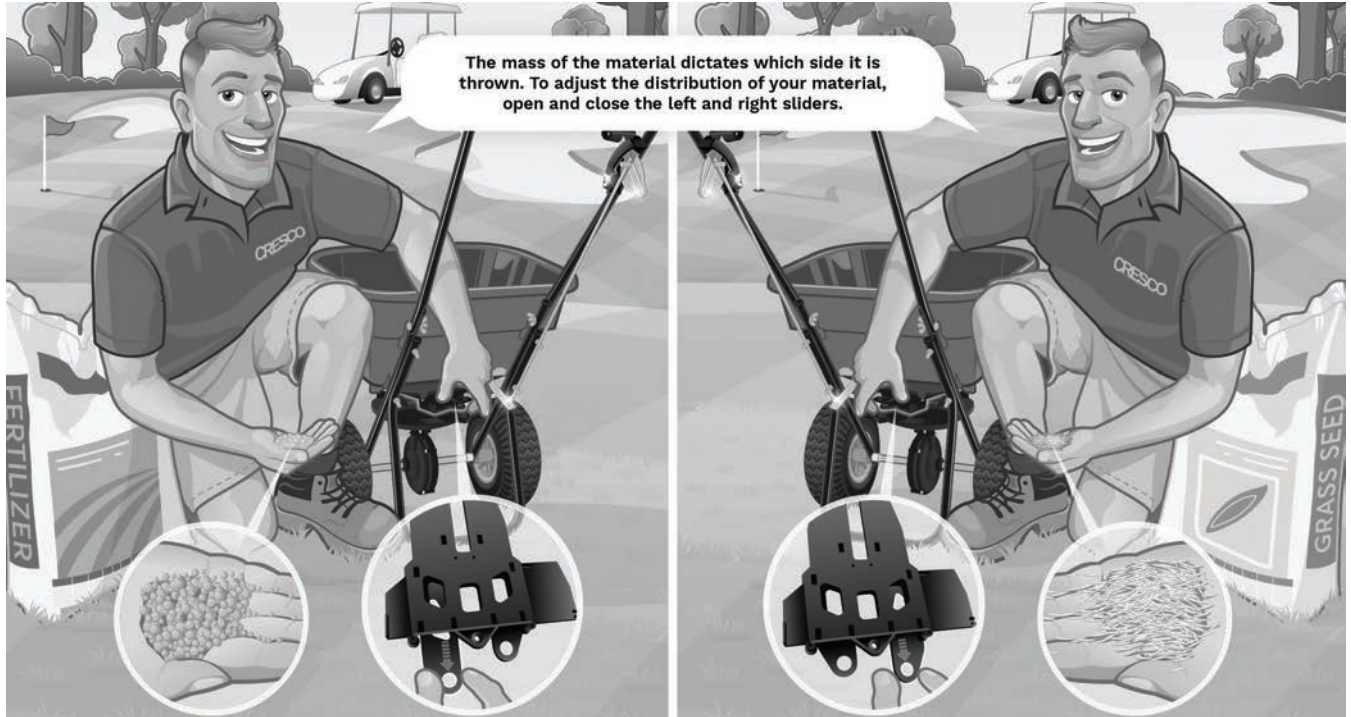

Border Control



To protect your borders simply slide the border control into position to cut off the left hand side of the spread pattern.

Slide System **Explanation**



PRODUCT	SUMMER SLIDER	SLIDER ADJUSTER SETTINGS
POWDERED OR MICRO GRANULAR FERTILIZER		NO ADJUSTMENT OF EITHER SLIDER RECOMENDED
MEDIUM GRANULAR FERTILIZER		NO ADJUSTMENT OF EITHER SLIDER RECOMENDED
LARGE GRANULAR FERTILIZER		ADJUSTMENT OF THE LEFT SLIDER RECOMENDED 6-7 CLICKS
GRASS SEED OR VERY LIGHT MATERIALS		ADJUSTMENT OF THE RIGHT SLIDER RECOMENDED 3-4 CLICKS
PELLETED MATERIALS		ADJUSTMENT OF THE LEFT SLIDER RECOMENDED (SELECT CLOSED)
LARGE GRANULAR ICE MELTS		ADJUSTMENT OF THE LEFT SLIDER RECOMENDED (SELECT CLOSED)

WINTER SLIDER

** Please note this chart is a guide only. Due to variations in the spreading characteristics of materials, accurate calibration should be carried out by the operator for each different material being applied. **

SHARP SAND		FULL OR REDUCED WIDTH SLIDER OPTION RECOMENDED
FLOWABLE SAND / SOIL MIX		FULL SLIDER WIDTH USE RECOMENDED
COARSE MARINE SALT		FULL OR REDUCED WIDTH SLIDER OPTION RECOMENDED
ROCK SALT		FULL SLIDER WIDTH USE RECOMENDED
GRIT MATERIALS		FULL SLIDER WIDTH USE RECOMENDED

WWW.CRESCOSPREADERS.COM

DMMP Limited is not responsible for misapplication due to incorrect use or incorrect calibration of Cresco spreaders, and any other DMMP Limited spreader brands.

For calibration information please refer to "how to calibrate" section on the Cresco website.



How to use the **Cresco 20**

How to Apply Fertilizer to your lawn like a pro in four steps!

Step 1: Understanding the application rate and settings

Step 2: Preparing the Spreader

Step 3: Walking Patterns for the optimum application

Step 4: Cleaning & Maintenance

Step 1: Understand the application rate and settings

Application Rate Settings

Check the back of the fertilizer bag to find out the recommended G/m² and spreader application setting.



If the spreader setting is not on the back of the bag, please get in touch with your fertilizer bag provider.



Set the handle to the correct setting.

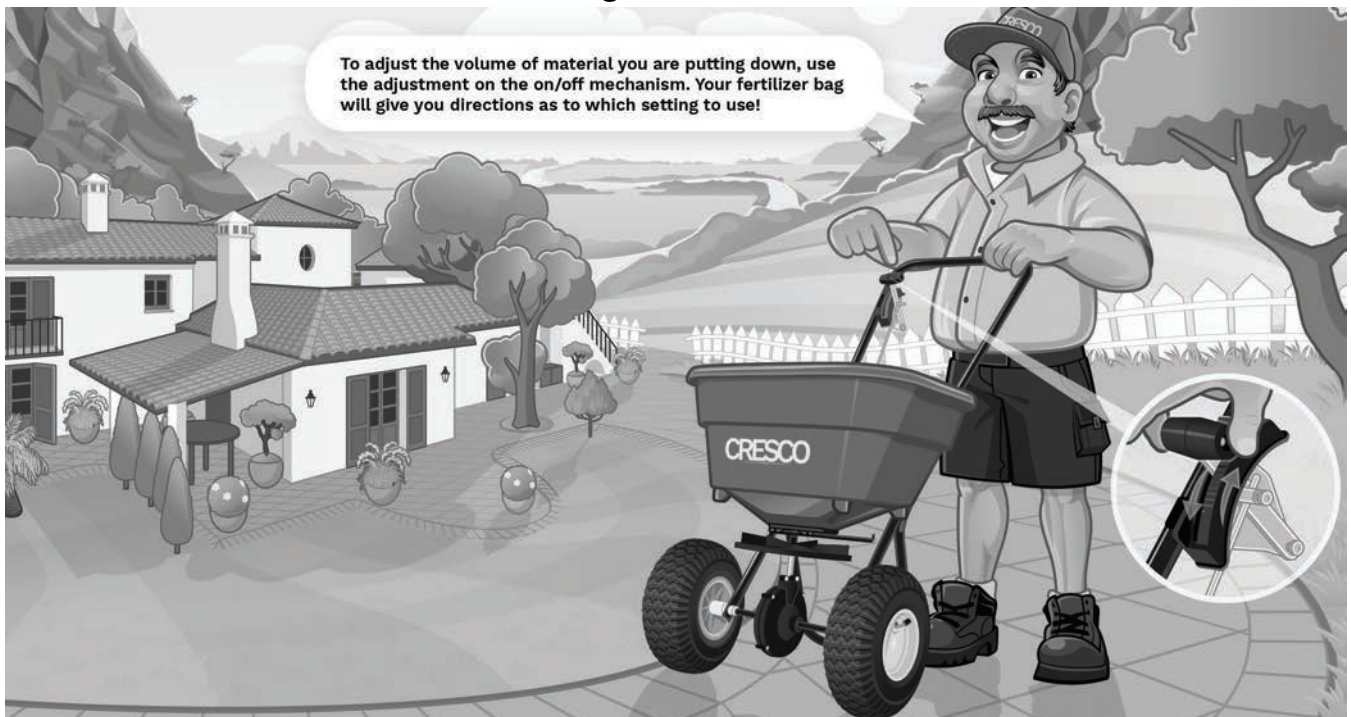

If you are unable to find the required Cresco volume setting, please visit, www.crescospreaders.com

How to use the Cresco 20

Spread Pattern Settings

Once you have the correct application rate, you will need to check that the spread of material is even on both sides of the spread pattern.

To balance the spread pattern for your material, check online or with your fertilizer or seed provider.

For a quick reference, please refer to our guide on the previous page



The chart is titled "CRESCO SLIDE-SYSTEM TECHNOLOGY SETTINGS" and "TWO SEASONS. ONE SPREADER." It shows a spreader on a lawn. Below the title are two circular icons of the spreader's slide system. The chart is organized into three columns: PRODUCT, SUMMER SLIDER, and SLIDER ADJUSTER SETTINGS. The first row shows "POWDERED OR MICRO GRANULAR FERTILIZER" with a pile of powder, a "SUMMER SLIDER" icon, and "NO ADJUSTMENT OF EITHER SLIDER RECOMENDED" with a slider icon. The second row shows "MEDIUM GRANULAR FERTILIZER" with a pile of granules, a "SUMMER SLIDER" icon, and "NO ADJUSTMENT OF EITHER SLIDER RECOMENDED" with a slider icon.

PRODUCT	SUMMER SLIDER	SLIDER ADJUSTER SETTINGS
POWDERED OR MICRO GRANULAR FERTILIZER		NO ADJUSTMENT OF EITHER SLIDER RECOMENDED 
MEDIUM GRANULAR FERTILIZER		NO ADJUSTMENT OF EITHER SLIDER RECOMENDED 

Step 2: Preparing the Spreader

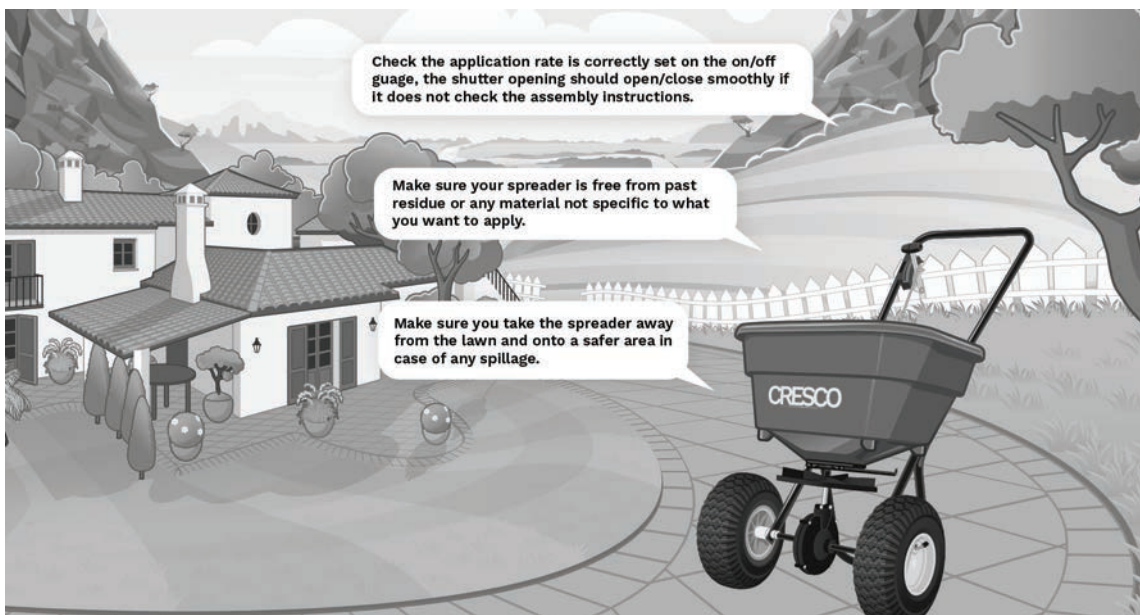

Check the material to be applied is dry and free flowing to ensure it will flow freely through the hopper. Make sure your application rate and spread pattern settings are correct, **close the application hole fully** and then pour in your material.

How to use the **Cresco 20**

Your outlet hole should look like this before you pour in any material.



WARNING **Do not pour material in the hopper when the application holes are open as it can lead to spillages or leaks that can damage the area. Do not open the gauge until you are over the area you want to spread and are moving at a brisk walk***

Step 3: Walking Patterns for the optimum application (For Fertilizer Only)

There are two methods of effective spreading, longitudinal fertilizer spreading and cross sectional fertilizer spreading.

When applying fertilizer please make sure you walk at 3mph and keep the hopper in a stable, upright position.

How to use the Cresco 20

Single Pass Fertilizer Spreading

Use ½ the application rate suggested on the back of your fertilizer bag.

Cover the area as shown by passing over it in an up and down track as shown, taking into account the spread width of the material being applied.

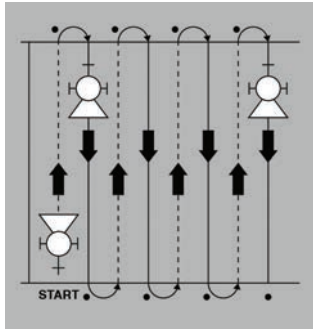

Cross Sectional Fertilizer Spreading

Use ½ the application rate suggested on the back of your fertilizer bag.

Cover the area as shown. Repeating by a second pass in the same manner going across the area as shown in the diagram.

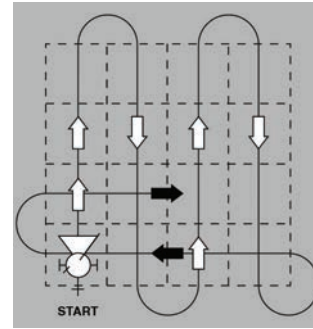

Step 4: Cleaning and Maintenance

CLEANING THE SPREADER THOROUGHLY WILL SIGNIFICANTLY ENHANCE THE LIFESPAN OF YOUR SPREADER AND IMPROVE IT'S ABILITY TO SPREAD EVENLY NEXT TIME YOU USE IT.



Calibration Setting Guide

Speed		05mm - 1mm			1mm - 2mm			3mm - 5mm		
Mph	3	3.5	3.5	4.0	4.0	4.0	4.5	4.5	4.5	4.5
Kph	4.828	20	35	20	35	50	20	35	50	50
Metres p/Sec	1.34	10	10	10	10	10	10	10	10	10
Product		13.4	13.4	13.4	13.4	13.4	13.4	13.4	13.4	13.4
Width	Metres	3.5	3.5	4.0	4.0	4.0	4.5	4.5	4.5	4.5
Application Rate	Grams /Sq M	20	35	20	35	50	20	35	50	50
Run Time	Secs	10	10	10	10	10	10	10	10	10
Distance	metres	13.4	13.4	13.4	13.4	13.4	13.4	13.4	13.4	13.4
Area	Sq Metres	47	47	54	54	54	60	60	60	60
Target Weight	Grams	938	1,876	938	1,876	3,015	938	1,876	1,876	3,015
Setting		8.5	11	14	11	19.5	13	18	16 (X2)	
Slider Position		-	-	-	-	-	7 Clicks LHS	7 Clicks LHS	7 Clicks LHS	

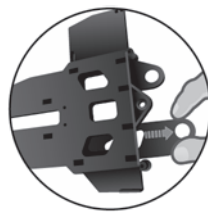

Left hand slider adjuster

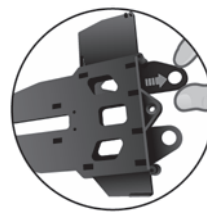

Right hand slider adjuster

LHS (Left hand slider adjuster) is recommended to be engaged when spreading large sized granular materials to provide a more uniform distribution on the left and right side of the spread pattern. Conversely with very light materials (e.g. grass seed) engaging the RHS (Right hand slider adjuster) will be similarly beneficial.

The manufacturer cannot be held responsible for any variations in sq. metre application volumes, or spread width differences, due to possible variations in materials, application conditions at the time and different operator application techniques.

Do not spread Fertiliser or seed materials with the winter slider

This chart should be used as a guide only.



3-Year **Limited Warranty**

DMMP Ltd. warrants this product free of defects in original workmanship and materials for a period of 3 Years to the end user with the original dated purchase receipt.

If a manufacturing non-conformance is found, DMMP Ltd. will repair or replace the part(s) or product at its discretion at no charge provided the failure is not the result of incorrect installation, mishandling, misuse, tampering, or normal wear and tear as determined by DMMP Ltd.

DMMP Ltd. at its discretion may require that the part(s) or product be returned along with the original purchase receipt at owners' expense for examination and compliance with the terms of this warranty.

Do not return any product without first receiving authorization from DMMP Ltd. To seek remedy under this warranty, contact DMMP Ltd. at +44 (0)1455 825 400 or email us at info@dmmp.co.uk and describe the nature of the manufacturing defect.

SPECIFIC LIMITATIONS:

This warranty covers only the part(s) or product; any labour charges associated with repair or replacement of nonconformances are specifically excluded.

Due to the corrosive nature of most fertilizers and ice melt products, DMMP Ltd makes no warranty against and specifically excludes part(s) or product degradation or failure due to corrosion or its effects.

To negate the effects of corrosive materials on your product, clean and dry your spreader or seeder thoroughly after each use. As a further preventative measure, coat all metal parts with a light oil or silicon spray.

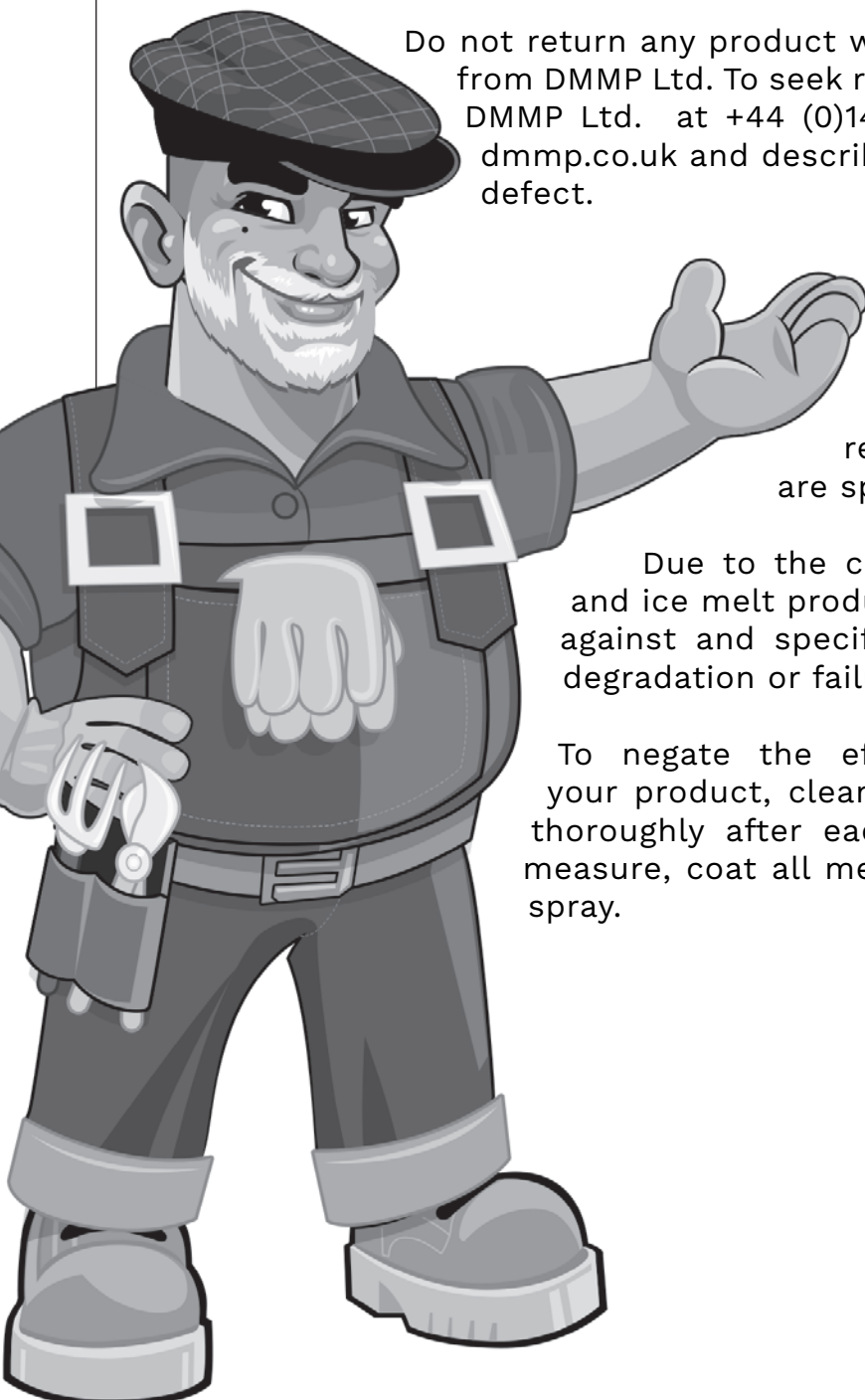

Other Cresco Products

Product / Season		Unique Selling Points	
 Cresco 1 Code: CR001		Ergonomic arm-rest handle for easy holding 	Large 2Kg Hopper 
 Cresco 5 Code: CR005		New heavy duty gearbox 	Easy to use on/off system 
 Cresco 8SW Code: CR008SW		Thick coating on cable linkage to prevent degradation 	Retractable back stand and folding handlebar for easy storage 
 Cresco 10SW Code: CR10SW		Cushioned on/off lever with solid rod linkage 	Large moulded wheels 
 Cresco 20SW Code: CR20SW		Cushioned on/off lever with solid rod linkage 	Pneumatic Wheels 
 Cresco SRS Code: CRSRS		Seed Plate Bag Included with 11 Seed Plates 	Strong row marker mounting 
 Heavy Duty Snow Shovel Code: H464P		Powder coated steel tubed handle 	Large comfortable ergonomic grip 
 Wide Snow Clearer Code: H611		Steel blade 	Steel edge to increase cutting power and longevity 
 3 in 1 Foldable Snow Shovel Code: HZS212		Anodised aluminium head 	Telescopic anodised aluminium handle 
 Cresco Snow Blaster Code: H595		Two grip design makes snow removal easy and minimises lifting and stooping 	Wave ribbed design reinforces blade strength 
 Polar Tough Snow Plough Code: YH74900		Helps manage snow accumulation 	Reduces labour costs compared to a shovel 