

# WALLSENZR

## BBT-702 Series

Low Voltage Wall Switch Sensor

### INSTALLATION INSTRUCTIONS

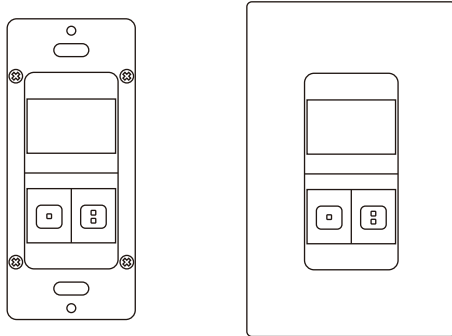

**INDOOR USE ONLY**

**Utilisation a L'interieur Uniquement**

#### **⚠ WARNING & CAUTION**

- Turn power OFF at circuit breaker before installing Power Pack or Sensors.
- Do NOT touch the square window of infrared sensor under the lens assembly.
- Do Not Install To and/or Cover a Junction Box Having Class 1, 3 or Power and Lighting Circuits
- Class 2 Device Wiring Only – Do Not Reclassify and Install as Class 1, 3 or Power and Lighting Wiring

#### **⚠ AVERTISSEMENT & PRUDENCE**

- Coupez l'alimentation au disjoncteur avant d'installer Power Pack ou capteurs.
- Ne PAS toucher la fenêtre carrée de capteur infrarouge sous l'ensemble de l'objectif
- Ne pas installer ou couvrir une boîte de jonction ayant les classes 1 et 3 ou circuits de puissance et d'éclairage.
- Classe 2 Câblage de périphériques Seulement - Ne PAS reclasser et installer Classe 1, 3 ou alimentation et circuits d'éclairage

### OVERVIEW

The BBT-702 series is a member of IR-TEC's WALLSENZR family of 2-pole low voltage wall switch sensor designed to fit in a standard NEMA wall box.

The BBT-702 contains two isolated dry contact outputs, and two push button signals, for controlling two lighting loads or circuits independently through the connected Power Packs or BMS. The sensor provides two independent momentary contact signals for Multi-way Manual Control (MMC) of the respective loads. The MMC is ideal for large area applications where may require multiple wall switch sensors and wall/ceiling mount sensors to cover the whole area, but with manual ON/OFF control available for specific purpose. To meet compliance of specific energy code, such as CA Title 24, the BBS-702 series can be used as vacancy sensor through specific wiring with PPU-300.

The model BBT-702S comes with an ambient light sensor (ALS) to inhibit its output if ambient light levels are higher than required. The Accu-Set digital potentiometers make delay time (TIME) and ambient light level (LUX) settings fast, easy and accurate. Two isolated dry contact outputs allow the BBT-702 series to control the separate loads with IR-TEC Power Packs or BMS/BAS.

### DETECTION COVERAGE

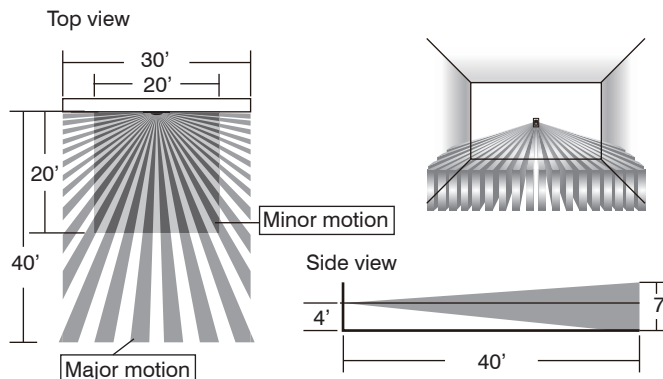

### INSTALLATION NOTES

1. The sensor is more sensitive to the movements "crossing" the detection zones than "toward" or "away" the sensor. To obtain better sensitivity, ensure the sensor to have clear field of view for the occupant's motion within the desired detection coverage.
2. The closer the movement is to the sensor, the more sensitive the sensor is.
3. The sensor should be mounted within the specified mounting height for optimal performance.
4. Avoid blocking the sensor with any obstacles, such as door, plant, partition or furniture. As a general rule, every occupant within the desired range should be able to clearly see the sensor.
5. Do NOT mount the sensor directly above or nearby a heat source, or where unintended motion (e.g. hallway traffic) will be "seen" by the sensor.

### SPECIFICATIONS

Power input	12~24 VDC $\pm$ 5%
Current drain	5/30 mA, 24VDC @vacant/occupied
Infrared sensor	Dual element pyroelectric
Control output	2 x Form A dry contact & active low
Contact rating	Max. 2A @30VDC, isolated
Detectable speed	1~10 ft./sec. (0.3~3 m/sec)
Mounting height	3 ~ 5 ft. (90~150 cm) above the floor
Detection coverage	Major motion - 30 ft x 40 ft (W x L) @4 ft H Minor motion - 20 ft x 20 ft (W x L) @4 ft H
Ambient light level	7 levels, from dark to 24 Hr.
Delay time setting	T/1'/3'/5'/10'/20'/30', T=10 sec. for testing
Op. humidity	Max. 95% RH, non-condensate
Op. temperature	-40°F ~ 131°F (-40°C ~ 55°C)
Dimensions	4.13"H x 1.77"W x 1.65"D (w/mounting plate)



www.irtec.com P/N: 058-70201-003

Printed in Taiwan

This product may be covered by one or more U.S. patents or patent applications. Please visit www.irtec.com for more information.



## WIRING DIAGRAM

### • Occupancy Sensing Control with PPU-300

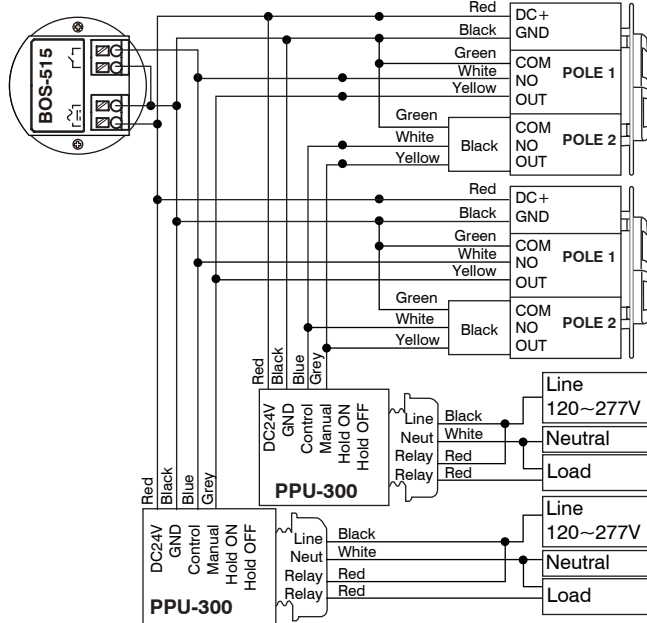

### • Vacancy Sensing Control with PPU-300

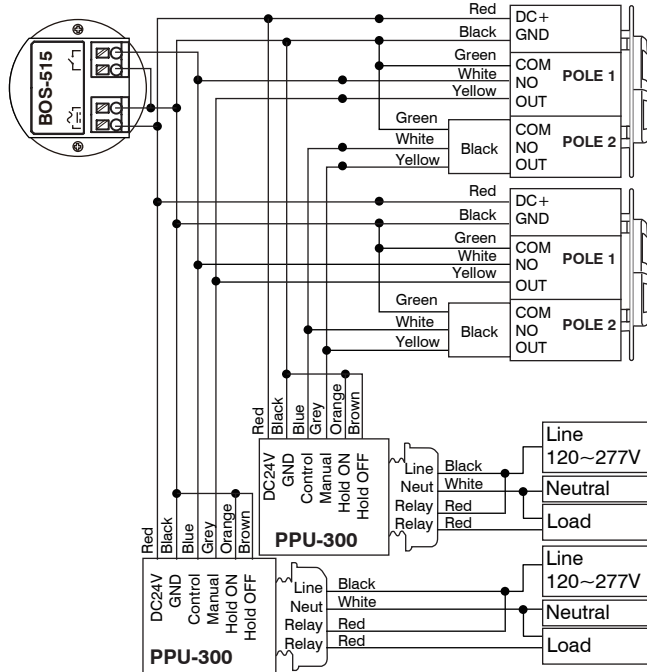

**NOTE:** Other IR-TEC low voltage occupancy sensor may be applicable, please contact sales team for more information.

## INSTALLATION

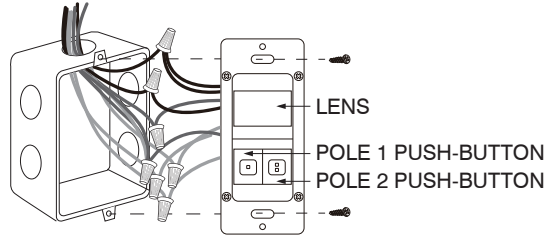

1. Install the power pack and connect the load according to its instructions.
2. Connect the low voltage wires of power pack with the respective wires of the sensor according to the diagram of desired control.
3. Turn ON the line voltage power for the power pack.
4. Conduct sensor operation test.
5. Attach the wallplate cover after testing and setting completed.

## OPERATION & SETTINGS

The BBT-702 series low voltage wall switch sensor employs passive infrared (PIR) sensing technology to monitor the occupancy status within its coverage, and provide two isolated dry contact outputs for the power packs to control the connected loads respectively. Two independent push-button signals are available for multi-way manual ON/OFF control.

The BBT-702S features adjustable light-off delay time and ambient light level to inhibit the unnecessary lighting when ambient light is higher than the level set. The time delay (TIME) and ambient light level (LUX) settings can be changed by rotating the respective Accu-Set potentiometer at different position. A DIP switch is available to program the control of pole-2 and lower the sensitivity.

### DIP Switch Settings

SW	#1 (Pole 2 control)	#2 (Sensitivity)
ON	POED	Standard
OFF	ALSO	Low

### POED – Pole One with Extended Delay

The sensor will control the connected load of pole 2 will as per pole 1 set but with Extended Delay (ED) for 5 minutes.

### ALSO – Ambient Light Sensing Only

The sensor will automatically turn ON the connected load of pole 2 when ambient light is lower than the LUX level set, and turn OFF the load when ambient light level is higher than the threshold.

To change the sensor settings, press the push-button cover and slide it down as shown.

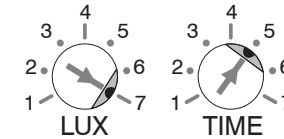
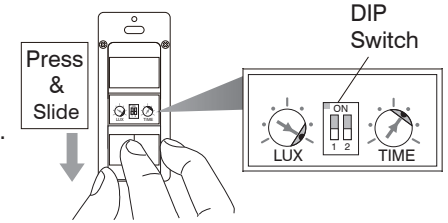

POS.	1	2	3	4	5	6	7
TIME	T	1'	3'	5'	10'	20'	30'
LUX	5	10	30	50	100	150	24H

Factory Set

### TIME - Delay time

This is the delay time that the BBT-702 series sensor will hold the load ON after the last motion detected. The factory setting is 10 minutes, and it can be changed by pointing the arrowhead of potentiometer to the specific position.

### LUX – Ambient light level

This is the threshold of ambient light level that the sensor will inhibit switching on the load. The factory setting is ALS disabled (24 Hr) for ease of testing, and it can be changed by pointing the arrowhead of potentiometer to the specific position.

## TESTING

After the sensor installed and wiring completed, sensor operation test can be conducted as instructed below

1. Apply the power to the Power Pack.
2. Walk within the desired coverage. LED will blink to indicate the motion sensed.
3. Replace the wall plate cover after completing the sensor test and setting.

**NOTE:** The connected load will be switched ON as delay time set (factory default 10 minutes) once apply the power. The delay time can be set to the shortest (10 seconds) for ease of testing. **Ensure to set the TIME as desired for optimum operation after testing.**

## WARRANTY

IR-TEC International Ltd. warranties this product to be free of defects in materials or workmanship for a period of five years from date of shipment. There are no obligations or liabilities on the part of IR-TEC International Ltd. for consequential damages arising out or in connection with the use or performance of this product or other indirect damages with respect to loss of property, revenue, or profit, or cost of removal, installation or reinstallation.