



LEVITON®

High Bay/Low Bay Passive Infrared Occupancy Sensor and Offset Adapter

- Cat. No. OSFHU-ITW (Sensor)
- Cat. No. OSFHU-CTW (Cold Storage)
- Cat. No. OSFOA-00W (Adapter, sold separately)
- Cat. No. OSFLO-00W (Adapter, sold separately)

Ratings:

800VA-6.67A @ 120VAC, 1/4 HP, 50-60Hz
 1200VA-4.33A @ 277VAC, 1/4 HP, 50-60Hz
 1500VA-4.32A @ 347VAC, 1/4 HP, 50-60Hz
 - 40° F to 160° F for Cat. No. OSFHU-CTW
 14° F to 160° F for Cat. No. OSFHU-ITW

Compatible with electronic and magnetic ballasts,
 electronic and magnetic low-voltage ballasts

INSTALLATION INSTRUCTIONS

PK-93439-10-00-5G

LIMITED 5 YEAR WARRANTY AND EXCLUSIONS

Leviton warrants to the original consumer purchaser and not for the benefit of anyone else that this product at the time of its sale by Leviton is free of defects in materials and workmanship under normal and proper use for five years from the purchase date. Leviton's only obligation is to correct such defects by repair or replacement, at its option. For details visit www.leviton.com or call 1-800-824-3005. This warranty excludes and there is disclaimed liability for labor for removal of this product or reinstallation. This warranty is void if this product is installed improperly or in an improper environment, overloaded, misused, opened, abused, or altered in any manner, or is not used under normal operating conditions or not in accordance with any labels or instructions. **There are no other or implied warranties of any kind, including merchantability and fitness for a particular purpose,** but if any implied warranty is required by the applicable jurisdiction, the duration of any such implied warranty, including merchantability and fitness for a particular purpose, is limited to five years. **Leviton is not liable for incidental, indirect, special, or consequential damages, including without limitation, damage to, or loss of use of, any equipment, lost sales or profits or delay or failure to perform this warranty obligation.** The remedies provided herein are the exclusive remedies under this warranty, whether based on contract, tort or otherwise.

For Technical Assistance Call:
 1-800-824-3005 (U.S.A. Only)
www.leviton.com

FOR CANADA ONLY

For warranty information and/or product returns, residents of Canada should contact Leviton in writing at Leviton Manufacturing of Canada Ltd to the attention of the **Quality Assurance Department, 165 Hymus Blvd, Pointe-Claire (Quebec), Canada H9R 1E9** or by telephone at **1 800 405-5320**.

FEATURES

- Fixture or electrical box mounted Passive Infrared Occupancy Sensor
- 360 degree lenses for field-of-view (included):
 - Blue Lens = 8-25ft mounting height
 - White Lens = 20-40ft mounting height
- Aisle Coverage: add included aisle mask to either lens option
- Adjustable Time Delay
- LED indicator light blinks when sensor detects motion
- 21" pre-stripped color coded wire leads
- Optional peel and stick mask kit
- Offset Adapters (sold separately)

DESCRIPTION

Leviton's High Bay Occupancy Sensors, Cat. No. OSFHU-ITW and OSFHU-CTW (cold storage), are specifically designed for high mounted areas such as warehouses, manufacturing and other high ceiling applications. The OSFHU-xTW installs directly to an industrial luminaire or an electrical junction box. It is a self-contained sensor and relay that detects motion using the passive infrared (PIR) to sense sources (such as a person entering a room) within its field-of-view (monitored space) and automatically switches lights ON. The controlled lights will remain ON until no motion is detected and the scheduled time-delay has expired. The OSFHU-xTW is supplied with two interchangeable lens rings that allows the user to select between a 360 degree High Bay/Low Bay pattern or an aisle pattern.

Cat. No. OSFHU-ITW is UL listed, cUL listed and conforms to California Title 24 requirements. The Sensor's High Bay lens is designed for 20 ft. to 40 ft. mounting heights for a symmetrical pattern which will provide coverage of 50' to 60' diameter (**refer to Figure 4 and 5**). The Low Bay lens is designed for 8 ft. to 25 ft. mounting heights for a symmetrical pattern which will provide coverage of 30' to 50' diameter (**refer to Figure 6**). The Sensor is sensitive to the heat emitted by the human body. In order to initially trigger the Sensor, the source of heat must move from one zone of detection to another.

Note that occupancy sensors respond to rapid changes in temperature, so care should be taken not to mount the device near a climate control source (i.e. radiators, air exchanges, and air conditioners). Hot or cold drafts will look like body motion to the device and will trigger it if the unit is mounted too close. **It is recommended to mount the Occupancy Sensor at least 6 ft. away from the heating or cooling ventilation source.**

INSTALLATION INSTRUCTIONS

WARNING: TO BE INSTALLED AND/OR USED IN ACCORDANCE WITH APPROPRIATE ELECTRICAL CODES AND REGULATIONS.

WARNING: IF YOU ARE NOT SURE ABOUT ANY PART OF THESE INSTRUCTIONS, CONSULT AN ELECTRICIAN.

WARNING: CONTROLLING A LOAD IN EXCESS OF THE SPECIFIED RATINGS WILL DAMAGE THE UNIT AND POSE RISK OF FIRE, ELECTRIC SHOCK, PERSONAL INJURY OR DEATH. CHECK YOUR LOAD RATINGS TO DETERMINE THE UNIT'S SUITABILITY FOR YOUR APPLICATION.

OTHER CAUTIONS AND NOTES:

1. DISCONNECT POWER WHEN SERVICING LUMINAIRE OR CHANGING BULBS.
2. USE THIS DEVICE WITH **COPPER OR COPPER CLAD WIRE ONLY**.
3. DO NOT ATTEMPT TO DISASSEMBLE OR REPAIR. CLEAN OUTER SURFACE WITH A DAMP CLOTH ONLY.

TO INSTALL:

NOTE: The OSFHU-xTW is supplied with two lens trim rings. The 360 degree High Bay lens (white color trim ring) is installed at the factory with the Low Bay lens (blue color trim ring) in the carton. Choose the correct lens for your fixture height location and add the black aisle mask if desiring to block detection outside of the aisle. See below for changing lens trim ring. The OSFHU-xTW Sensor mounts in a 1/2" knock out hole on the end of a luminaire or an electrical box. The Sensor's field-of-view may be partially obstructed by the luminaire housing (**refer to Figure 1A**). At higher mounting heights, the outer beams are not used. As long as the bottom of the sensor is mounted within 1" from the bottom of the luminaire, the field-of-view will not be affected (**refer to Figure 1B**).

ADAPTER NOTE: For deep bodied luminaires or to clear other obstructions use Leviton's OSFOA-00W Adapter (**refer to Figure 2A**). The Adapter is designed to provide multiple mounting positions to accommodate different mounting heights for optimum sensor positioning (**refer to Figure 2B**). Provided is a keyed, threaded snap-in nipple that holds the Adapter in place while tightening the provided lock-nut. If the Adapter is needed, go to **ADAPTER INSTALLATION** section. The OSFLO is a single height position adapter with a quick install snap in fitting without a lock nut (**refer to Figure 2B**).

SENSOR INSTALLATION:

1. **WARNING:** TO AVOID FIRE, SHOCK, OR DEATH: **TURN OFF POWER AT CIRCUIT BREAKER OR FUSE AND TEST THAT THE POWER IS OFF BEFORE WIRING.**
2. The sensor comes with two lens rings, a white one for 360 degree High Bay detection (installed at factory), and a blue one for Low Bay applications. **NOTE:** Masking is provided to customize your detection area. Aisle mask can be inserted inside the lens and an optional peel and stick masking kit is included. This circular white adhesive label (with removable wedges) is applied to the OUTSIDE of the sensor lens. Use any number of wedges to alter field-of-view for your desired application.
3. To change lens, turn trim ring so that the two indented dots line up and pull out by the finger tabs (**refer to Figure 7A**).
4. If desired, insert black aisle mask into underside of lens assembly. **NOTE:** Position aisle mask according to aisle direction (**refer to Figure 7B**).
5. Line up dots and turn trim ring to set lens.
6. Remove the lock-nut from the threaded nipple and insert the wires and the threaded nipple into a half inch hole of the luminaire body or the electrical box.
7. Slide the lock-nut over the wires and thread clockwise on to the threaded nipple to secure the sensor firmly in place making sure the lens is orientated towards the area to be monitored (field-of-view). **TIGHTEN** to 4 ft-lbs of torque **NEVER USE MORE THAN 5** ft-lbs of torque (**refer to Figure 3**).
8. Connect wires per **Wiring Diagram** as follows: BLACK lead to LINE (Hot); RED lead to LOAD; WHITE lead to LINE (Neutral). Twist strands of each lead tightly and, with circuit conductors, push firmly into the appropriate wire connector. Screw connector on clockwise making sure that no bare wire shows below the connector.
9. Restore power at circuit breaker or fuse.

NOTE: Allow approximately 1 minute for charge-up. If the lights turn ON and the LED blinks when a hand is waved in front of the lens, then the Sensor was installed properly. If the operation is different, refer to the Troubleshooting Section.

The Sensor is factory preset to work without any adjustments. If you desire to change the factory settings, refer to the **SETTINGS** section.

OSFOA ADAPTER INSTALLATION:

1. Position one half of the Adapter body on the end of the luminaire to determine the appropriate mounting hole to be used on the Adapter that will position the sensor for optimum coverage. The bottom of the sensor should be at or below the luminaire body (**refer to Figure 2B**).
2. Punch out the keyed hole of the Adapter half body to be mounted on the luminaire or electrical box (**refer to Figure 1B**).
3. Thread the provided lock nut part way on the keyed threaded nipple and insert through the keyed hole from the inside of the Adapter half body and snap into the half inch hole of the luminaire or electrical box and tighten (**refer to Figure 2A**).
4. Punch out the non-keyed hole on the other Adapter body half and insert the wires and threaded nipple of the Sensor into the hole. Thread the provided lock nut on the nipple and tighten positioning sensor towards the area to be monitored (**refer to Figure 2A**).
5. Feed the sensor wires through the keyed nipple attached to the luminaire or electrical box and connect per **Wiring Diagram** as follows: BLACK lead to LINE (Hot); RED lead to LOAD; WHITE lead to LINE (Neutral). Twist strands of each lead tightly and, with circuit conductors, push firmly into the appropriate wire connector. Screw connector on clockwise making sure that no bare wire shows below the connector.
6. After wiring connections are completed, snap the two Adapter body halves together.

NOTE: To open the Adapter, use a small, flat blade screw driver and carefully insert into slots and push tabs down while pulling the two halves apart.
7. Restore power at circuit breaker or fuse.

NOTE: Allow approximately 1 minute for charge-up. If the lights turn ON and the LED blinks when a hand is waved in front of the lens, then the Sensor was installed properly. If the operation is different, refer to the Troubleshooting Section.

OSFLO ADAPTER INSTALLATION:

1. Position the adapter half with the insert nipple to the end of the luminaire or electrical box to determine if sensor will be positioned correctly for optimum coverage.
2. If appropriate position for coverage, insert the snap fitting into the knockout of the luminaire or electrical box (if added depth is needed for coverage, use the OSFOA with multiple positions).
3. Remove the locknut from the sensor and insert the wire leads through the mounting hole of the other half of the adapter. Slide locknut over wire leads and thread onto threaded sensor nipple and tighten so that sensor does not move. Align sensor so that it is parallel to the bottom of the luminaire or electrical box.
4. Feed the sensor wire through the adapter half mounted on the luminaire or electrical box and into the wire access area.
5. Snap the adapter half with the sensor attached to the adapter half on the luminaire or electrical box by aligning the snap fittings and pushing firmly together.
6. Connect per **Wiring Diagram** as follows: BLACK lead to LINE (Hot), RED lead to LOAD, WHITE lead to LINE (Neutral). Twist strands of each lead tightly and with circuit conductors, push firmly into appropriate wire connector. Screw connector on clockwise making sure no bare wires show below the connector.
7. Restore power at circuit breaker or fuse.

NOTE: Allow approximately 1 minute for charge-up. If the lights turn ON and the LED blinks when a hand is waved in front of the lens, then the Sensor was installed properly. If the operation is different, refer to the Troubleshooting Section.

SETTINGS

Time-Delay: Settings should be determined during the installation period. This adjustment controls the amount of time the lights stay ON after the last detected motion. You may select settings varying from 30 seconds to 20 minutes and any time in between.

NOTE: After power is turned ON, allow two minutes for this unit to warm up before performing Time-Delay settings.

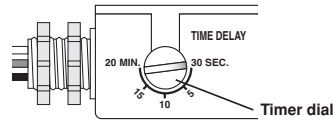

TROUBLESHOOTING

- **Lights will not turn ON**
 - **Circuit breaker or fuse is OFF:** Turn the breaker ON. Ensure the lights being controlled are in working order (i.e., working bulbs, ballasts, etc.)
 - **Sensor is wired incorrectly or may be defective:** Confirm that the sensor's wiring is done correctly and inspect visually for problems.
 - **Lens is dirty or obstructed:** Inspect the lens visually and clean if necessary, or remove the obstruction.
- **Lights will not turn OFF**
 - **Sensor is wired incorrectly or may be defective:** Confirm that the sensor's wiring is done correctly and inspect visually for problems.
 - **Sensor may be mounted too closely to an air conditioning or heating vent:** Move the sensor or close the vent.
 - **The line voltage has dropped:** Perform the necessary tests to ensure the line voltage has not dropped beneath 100V.
- **Lights turn OFF and ON too quickly**
 - **Sensor may be mounted too closely to an air conditioning or heating vent:** Move the sensor to another location or close the vent.
 - **Time delay set improperly:** Adjust the TIME DELAY.

Wiring Diagram

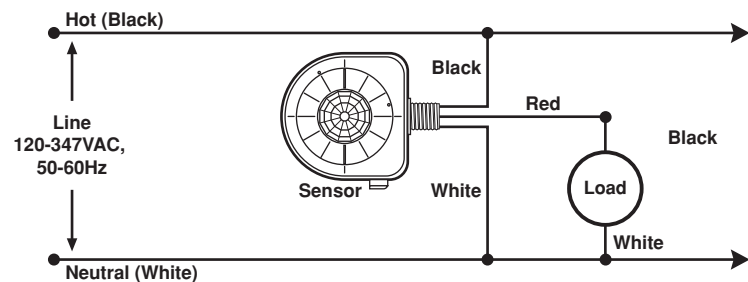

Figure 1A

INCORRECT

Sensor mounted too high
Outer beams are obstructed
Field-of-view is limited

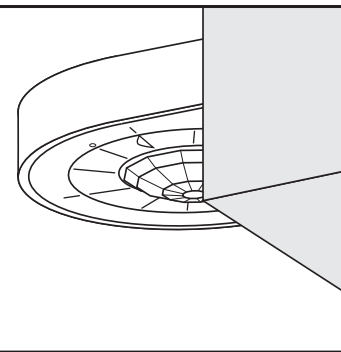

Figure 1B

CORRECT

Sensor mounted within 1" of bottom
No obstruction
Optimum field-of-view

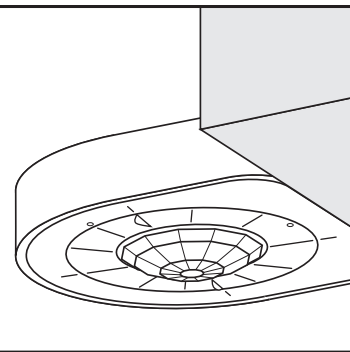
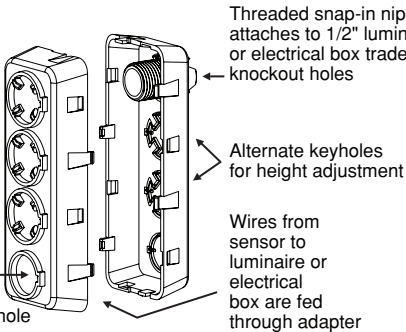

Figure 2A

OSFOA-00W Adapter

Sensor mounts here (non-keyed) hole



OSFLO-00W Adapter

Sensor mounts here (non-keyed) hole

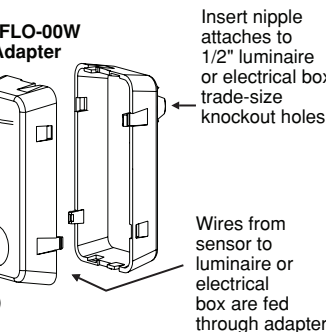

Figure 2B

OSFOA-00W Adapter (shown)

Sensor

Adapter allows sensor to be mounted to achieve optimum field-of-view

1/2" trade-size knockout hole

Figure 3

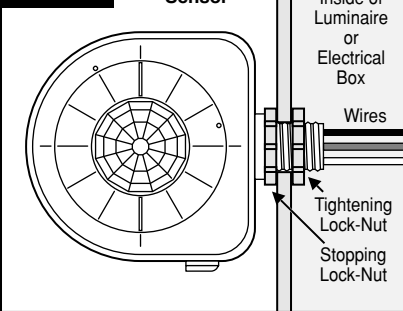

Figure 4

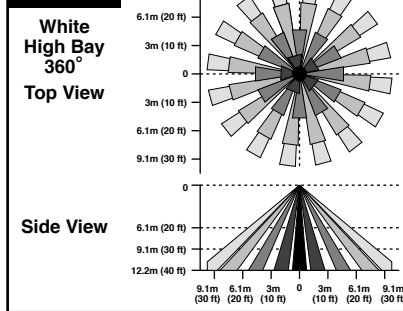

Figure 5

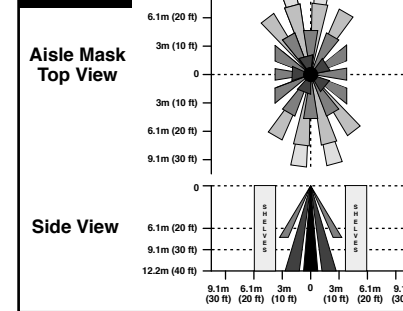

Figure 6

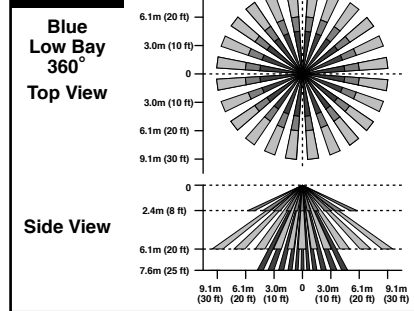

Figure 7A

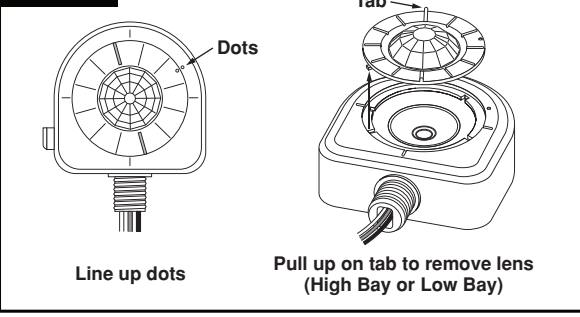

Figure 7B

