

DUNAVOX Grande-166

DX-166.428DBK EAN: 5999558431648

DX-166.428SDSK EAN: 5999558432034

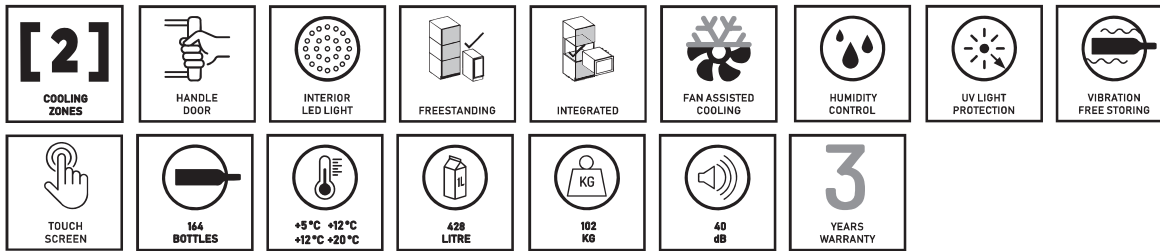

Door frame	Full glass black door / Stainless steel frame
Door reversible	Yes
Glass	Double glazed
Bottle capacity	166 bordeaux bottles
Bottle types	Bordeaux, Rhone, Champagne
Temperature zones	2
Door opening	Recessed (black only), SS with handle
Lock	Yes
Door opening sensor	No
Height	1765 mm
Width	595 mm
Depth	676 mm
Internal height	1580 mm
Internal width	520 mm
Internal depth	Upper:7x530 mm Lower:6x530 mm/390 mm
Packing height	1905 mm
Packing width	660 mm
Packing depth	745 mm
Installation	Integrated and freestanding
Ventilation design	Front Plinth Ventilation*
Display type	LED
Display colour	Blue
Interior light	LED lighting
Interior light colour	Blue
Shelves	14x wooden shelves
Shelf height	150 mm/6x85 mm/90 mm/7x 85 mm
Internal air circulation	Yes, fan assisted
Upper temperature range	5-12 °C**
Middle temperature range	-
Lower temperature range	12-20 °C
Temperature memory function	Yes, in case of power failure
Defrosting	Manual
Carbon filter	Yes
Grille	Yes
Total volume	418 L
Cabinet material	Metal
Cabinet colour	Black
Optimal usage	Domestic or commercial
Vibration free-storing	Yes
Internal humidity	50-80%
Warranty	3 years
Compressor warranty	5 years

Energy class	G
Annual energy consumption	192 kWh/annum
Daily energy consumption	0,526 kWh/daily
Power	220-240V AC 50Hz
Rated current	1.2 A
Cable length	2 m
Noise level	40 dB
Climate class	N
Cooling method	Compressor
Refrigerant type	R600a
Refrigerant amount	51 g
Handle	Black
Net weight	100 Kg
Gross weight	112 Kg

DX-166.428DBK



DX-166.428SDSK



* The grill must be free, because the air exchanges through here. The warm air from the compressor escapes, and the fresh air going in as well.

** The top zone must be cooler than the lower zone.

Bottle loading

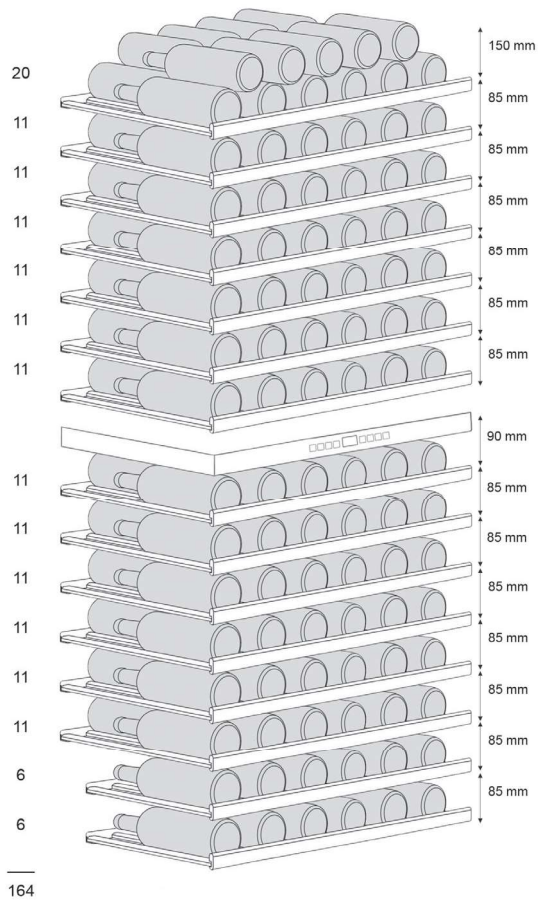

Energy label

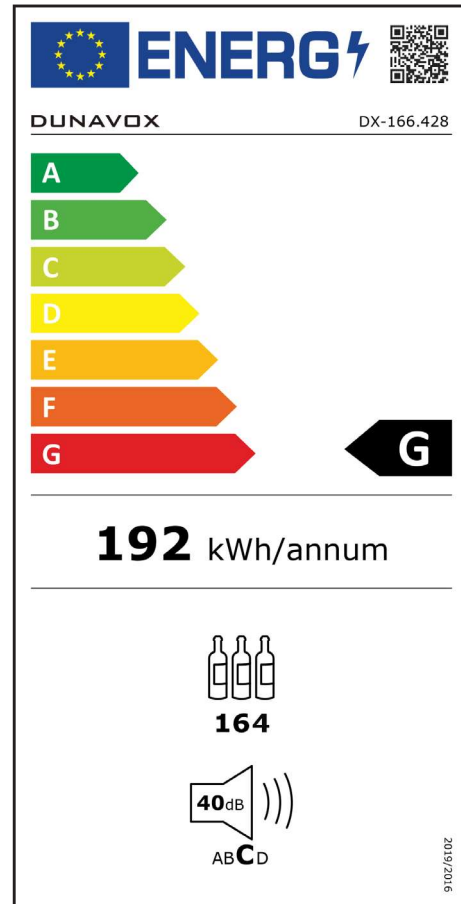

Installation drawing

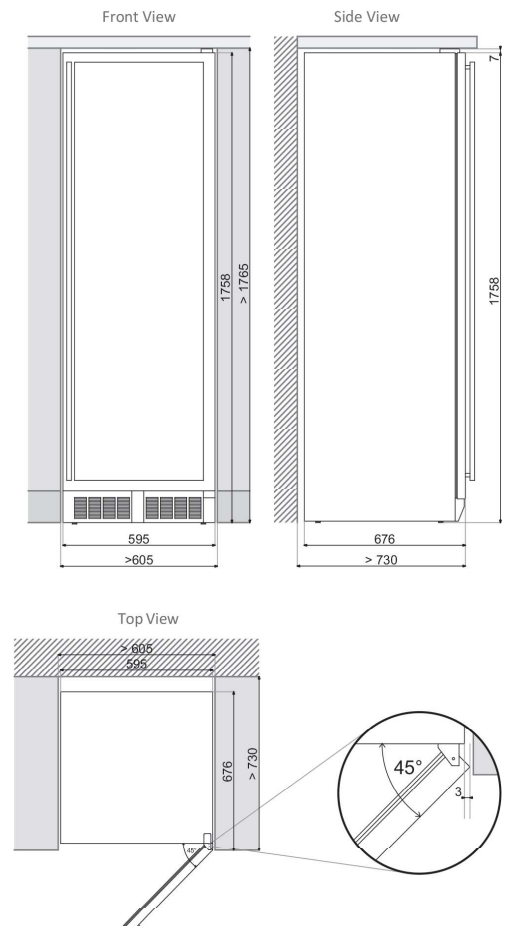
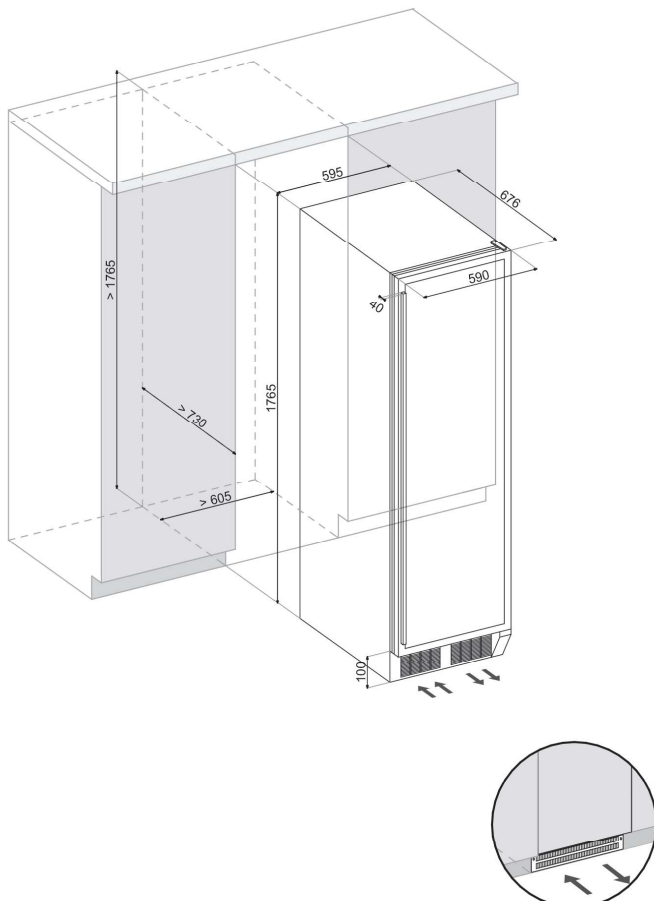

Dunavox reserves the right to change specification without prior notice.