

# DUNAVOX Flow-45

DAUF-45.125DB.TO EAN: 5999558434540

DAUF-45.125DSS.TO EAN: 5999558434557

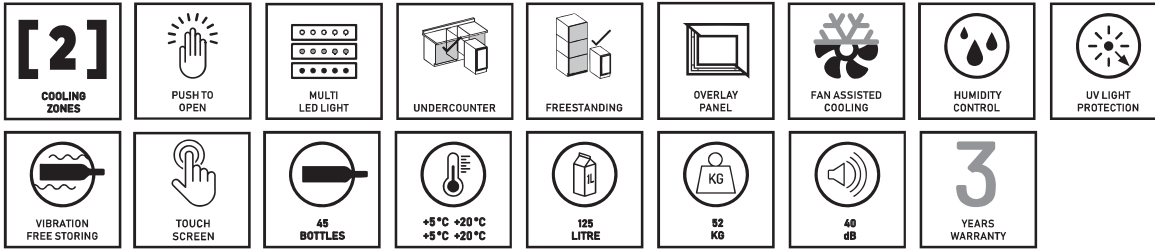

Door frame	Full glass black door / Stainless steel frame
Door reversible	Yes
Glass	Triple glazed
Bottle capacity	45 bordeaux bottles
Bottle types	Bordeaux, Rhone
Temperature zones	2
Door opening	Push to open
Lock	No
Door opening sensor	Yes
Height	880 mm
Width	595 mm
Depth	575 mm
Internal height	650 mm
Internal width	510 mm
Internal depth	Upper:440 mm/400 mm Lower:2x440 mm/310 mm
Packing height	940 mm
Packing width	660 mm
Packing depth	660 mm
Installation	Undercounter and freestanding
Ventilation design	Front Plinth Ventilation*
Display type	LED
Display colour	White
Interior light	LED lighting
Interior light colour	White, amber and blue
Shelves	4x Wooden shelves
Shelf height	2x90 mm/190 mm/2x90 mm
Internal air circulation	Yes, fan assisted
Upper temperature range	5-20 °C**
Middle temperature range	-
Lower temperature range	5-20 °C
Temperature memory function	Yes, in case of power failure
Defrosting	Manual
Carbon filter	Yes
Grille	Yes
Total volume	125 L
Cabinet material	Metal
Cabinet colour	Black
Optimal usage	Domestic
Vibration free-storing	Yes
Internal humidity	50-80%
Warranty	3 years
Compressor warranty	5 years

Energy class	G
Annual energy consumption	115 kWh/annum
Daily energy consumption	0,315 kWh/daily
Power	220-240V AC 50Hz
Rated current	1.2A
Cable length	2 m
Noise level	40 dB
Climate class	ST
Cooling method	Compressor
Refrigerant type	R600a
Refrigerant amount	36 g
Handle	-
Net weight	52 Kg
Gross weight	56 Kg

DAUF-45.125DB.TO

DAUF-45.125DSS.TO

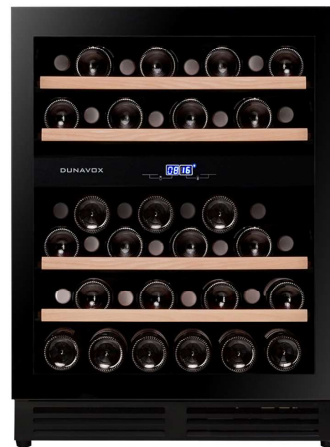

\* The grill must be free, because the air exchanges through here. The warm air from the compressor escapes, and the fresh air going in as well.

\*\* The top zone must be cooler than the lower zone, recommended temperature difference is 4°C.

## Bottle loading

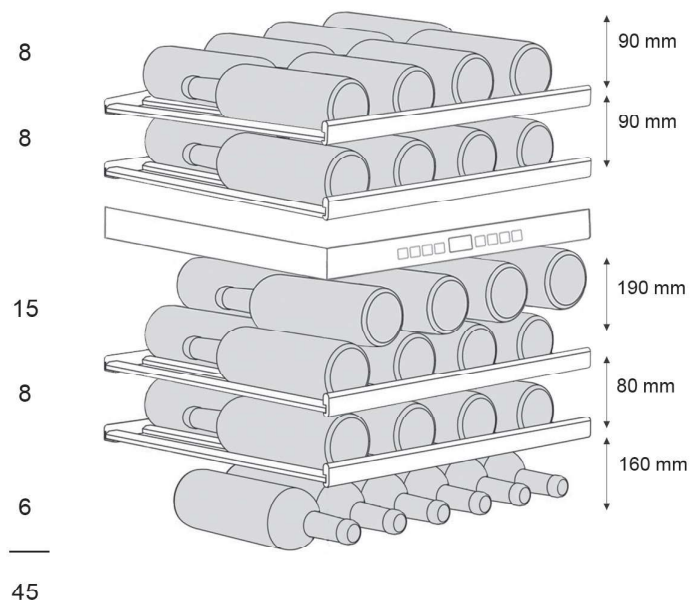

## Energy label

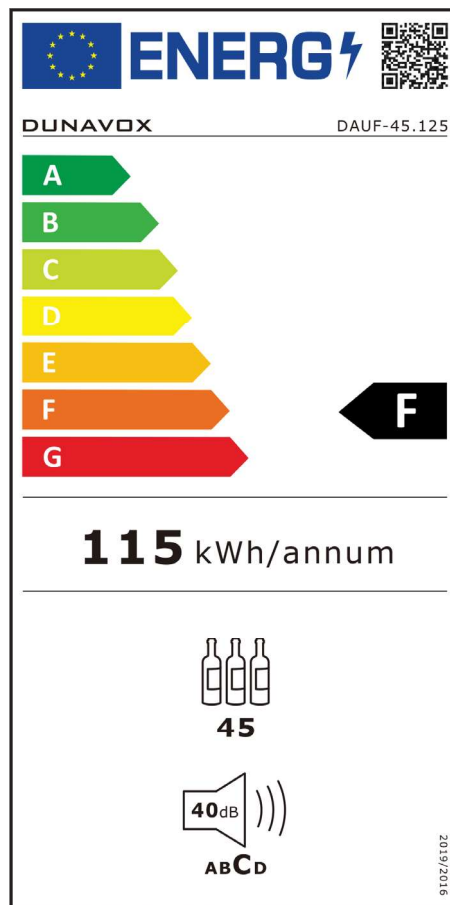

## Installation drawing

