

# DUNAVOX Flow-40

DAUF-40.138B EAN: 5999558433482

DAUF-40.138SS EAN: 5999558433499



<b>Door frame</b>	Full glass black door / Stainless steel frame
<b>Door reversible</b>	Yes
<b>Glass</b>	Triple glazed
<b>Bottle capacity</b>	40 bordeaux bottles
<b>Bottle types</b>	Bordeaux, Rhone, Champagne
<b>Temperature zones</b>	1
<b>Door opening</b>	With handle
<b>Lock</b>	No
<b>Door opening sensor</b>	No
<b>Height</b>	813 mm
<b>Width</b>	595 mm
<b>Depth</b>	570 mm
<b>Internal height</b>	650 mm
<b>Internal width</b>	500 mm
<b>Internal depth</b>	7x440 mm/310 mm
<b>Packing height</b>	880 mm
<b>Packing width</b>	660 mm
<b>Packing depth</b>	625 mm
<b>Installation</b>	Undercounter
<b>Ventilation design</b>	Front Plinth Ventilation*
<b>Display type</b>	LED
<b>Display colour</b>	White
<b>Interior light</b>	LED lighting
<b>Interior light colour</b>	White, amber, blue
<b>Shelves</b>	4x Telescopic rail
<b>Shelf height</b>	190 mm/3x130 mm 120 mm/3x130 mm/160 mm
<b>Internal air circulation</b>	Yes, fan assisted
<b>Upper temperature range</b>	-
<b>Middle temperature range</b>	5-20 °C
<b>Lower temperature range</b>	-
<b>Temperature memory function</b>	Yes, in case of power failure
<b>Defrosting</b>	Manual
<b>Carbon filter</b>	No
<b>Grille</b>	Yes
<b>Total volume</b>	138 L
<b>Cabinet material</b>	Metal
<b>Cabinet colour</b>	Black
<b>Optimal usage</b>	Domestic
<b>Vibration free-storing</b>	Yes
<b>Internal humidity</b>	50-80%
<b>Warranty</b>	3 years
<b>Compressor warranty</b>	5 years

<b>Energy class</b>	E
<b>Annual energy consumption</b>	83 kWh/annum
<b>Daily energy consumption</b>	0,227 kWh/daily
<b>Power</b>	220-240V AC 50Hz
<b>Rated current</b>	0.85 A
<b>Cable length</b>	1,5 m
<b>Noise level</b>	38 dB
<b>Climate class</b>	ST, N
<b>Cooling method</b>	Compressor
<b>Refrigerant type</b>	R600a
<b>Refrigerant amount</b>	28 g
<b>Handle</b>	Inox
<b>Net weight</b>	43 Kg
<b>Gross weight</b>	47 Kg

DAUF-40.138B

DAUF-40.138SS



\* The grill must be free, because the air exchanges through here. The warm air from the compressor escapes, and the fresh air going in as well.

## Bottle loading

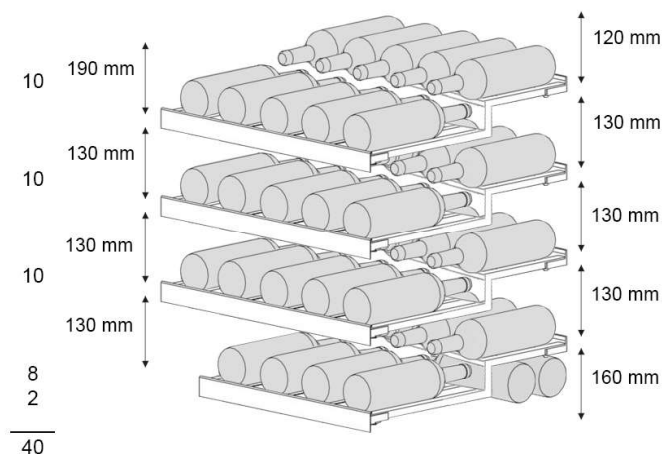

## Energy label

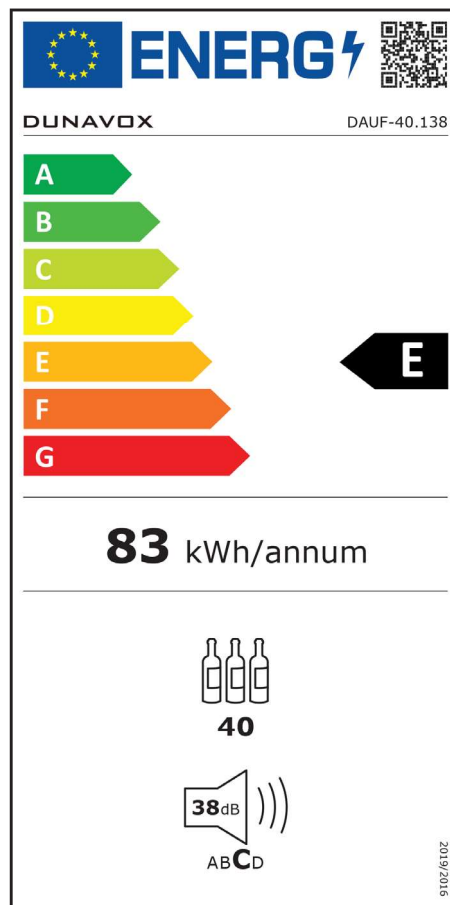

## Installation drawing

