

DUNAVOX Flow-38

DAUF-38.100DB EAN: 5999558435035

DAUF-38.100DSS EAN: 5999558435042

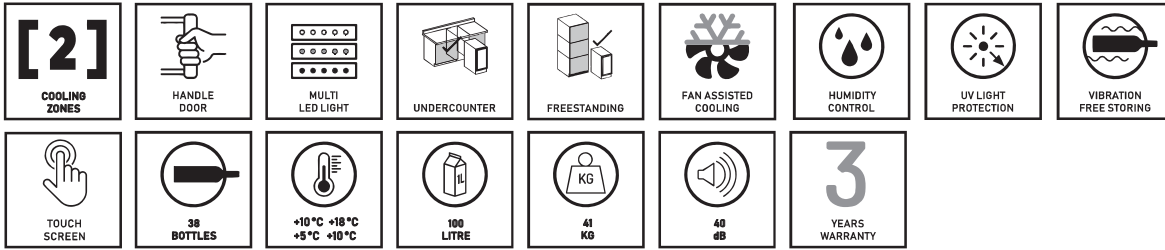

Door frame	Full glass black door / Stainless steel frame
Door reversible	Yes
Glass	Triple glazed
Bottle capacity	38 bordeaux bottles
Bottle types	Bordeaux, Rhone
Temperature zones	2
Door opening	With handle
Lock	No
Door opening sensor	Yes
Height	820 mm
Width	495 mm
Depth	575 mm
Internal height	640 mm
Internal width	415 mm
Internal depth	Upper:450 mm/400 mm Lower:3x450 mm/310 mm
Packing height	880 mm
Packing width	560 mm
Packing depth	660 mm
Installation	Undercounter and freestanding
Ventilation design	Front Plinth Ventilation*
Display type	LED
Display colour	White
Interior light	LED lighting
Interior light colour	White, amber and blue
Shelves	5x Wooden shelves
Shelf height	2x85 mm/105 mm/2x85 mm/95 mm
Internal air circulation	Yes, fan assisted
Upper temperature range	5-20 °C**
Middle temperature range	-
Lower temperature range	5-20 °C
Temperature memory function	Yes, in case of power failure
Defrosting	Manual
Carbon filter	No
Grille	Yes
Total volume	100 L
Cabinet material	Metal
Cabinet colour	Black
Optimal usage	Domestic
Vibration free-storing	Yes
Internal humidity	50-80%
Warranty	3 years
Compressor warranty	5 years

Energy class	G
Annual energy consumption	141 kWh/annum
Daily energy consumption	0,386 kWh/daily
Power	220-240V AC 50Hz
Rated current	1.2 A
Cable length	2 m
Noise level	40 dB
Climate class	ST
Cooling method	Compressor
Refrigerant type	R600a
Refrigerant amount	28g
Handle	Inox
Net weight	41 Kg
Gross weight	44 Kg

DAUF-38.100DB



DAUF-38.100DSS



* The grill must be free, because the air exchanges through here. The warm air from the compressor escapes, and the fresh air going in as well.

** The top zone must be cooler than the lower zone, recommended temperature difference is 4°C.

Bottle loading

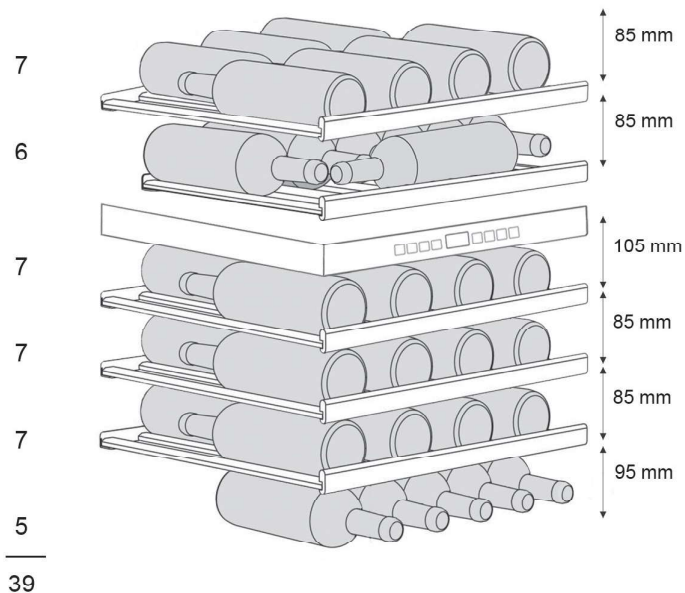

Energy label

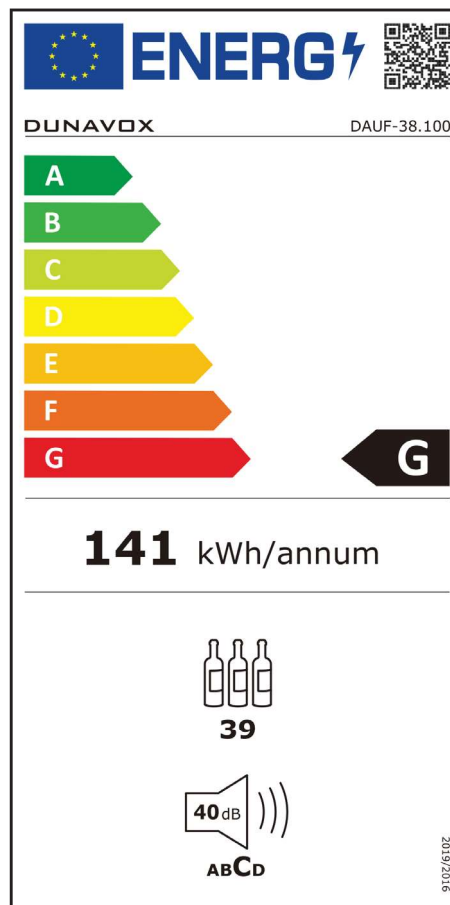

Installation drawing

