

DUNAVOX Flow-32D

DAUF-32.78DB EAN: 5999558434861
DAUF-32.78DSS EAN: 5999558434717

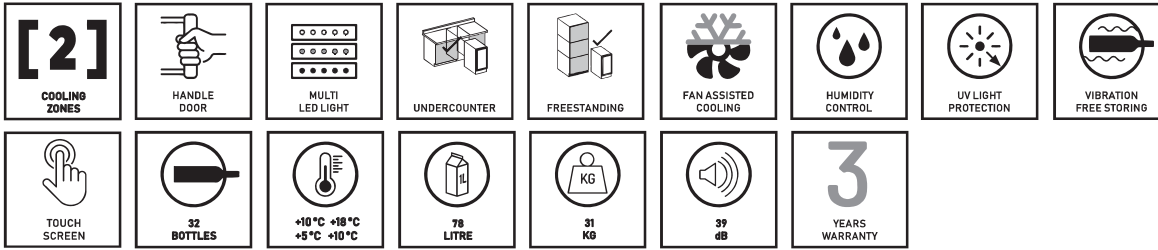

Door frame	Full glass black door / Stainless steel frame
Door reversible	Yes
Glass	2 layer+Low E glass
Bottle capacity	32 bordeaux bottles
Bottle types	Bordeaux, Rhone
Temperature zones	2
Door opening	With handle
Lock	No
Door opening sensor	Yes
Height	820 mm
Width	380 mm
Depth	563 mm
Internal height	650 mm
Internal width	315 mm
Internal depth	Upper: 2x440 mm Lower: 2x440 mm/300 mm
Packing height	845 mm
Packing width	415 mm
Packing depth	625 mm
Installation	Undercounter and freestanding
Ventilation design	Front Plinth Ventilation*
Display type	LED
Display colour	White
Interior light	Soft LED
Interior light colour	White, amber and blue
Shelves	4x Wooden shelves
Shelf height	130 mm/80 mm/100 mm/85 mm/150 mm
Internal air circulation	Yes, fan assisted
Upper temperature range	5-10 °C**
Middle temperature range	-
Lower temperature range	10-18 °C
Temperature memory function	Yes, in case of power failure
Defrosting	Manual
Carbon filter	Yes
Grille	Yes
Total volume	78 L
Cabinet material	Metal
Cabinet colour	Black
Optimal usage	Domestic
Vibration free-storing	Yes
Internal humidity	50-80%
Warranty	3 years
Compressor warranty	5 years

Energy class	G
Annual energy consumption	125 kWh/annum
Daily energy consumption	0,342 kWh/daily
Power	220-240V AC 50Hz
Rated current	0,5 A
Cable length	2 m
Noise level	39 dB
Climate class	N
Cooling method	Compressor
Refrigerant type	R600a
Refrigerant amount	20g
Handle	Inox
Net weight	31 Kg
Gross weight	34 Kg

DAUF-32.78DB

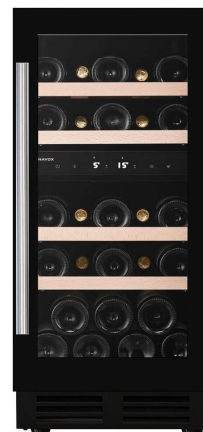

DAUF-32.78DSS



* The grill must be free, because the air exchanges through here. The warm air from the compressor escapes, and the fresh air going in as well.

** The top zone must be cooler than the lower zone.

Bottle loading

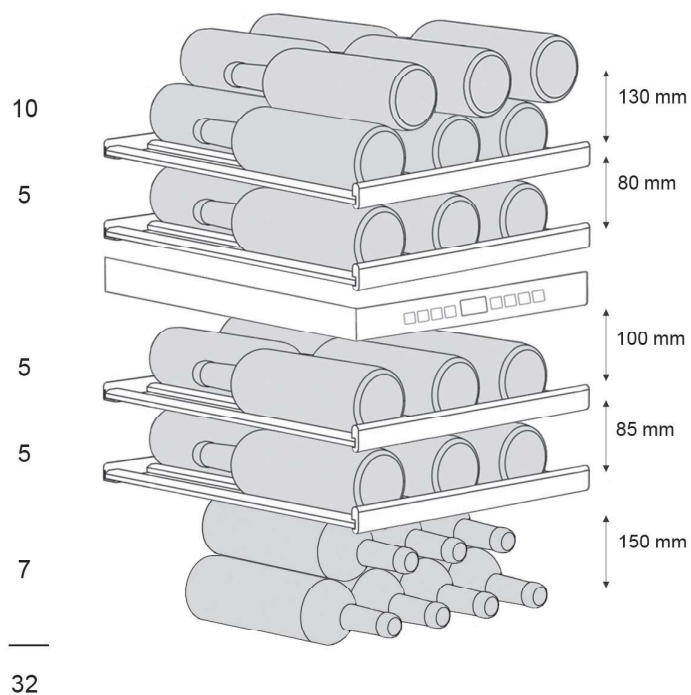

Energy label

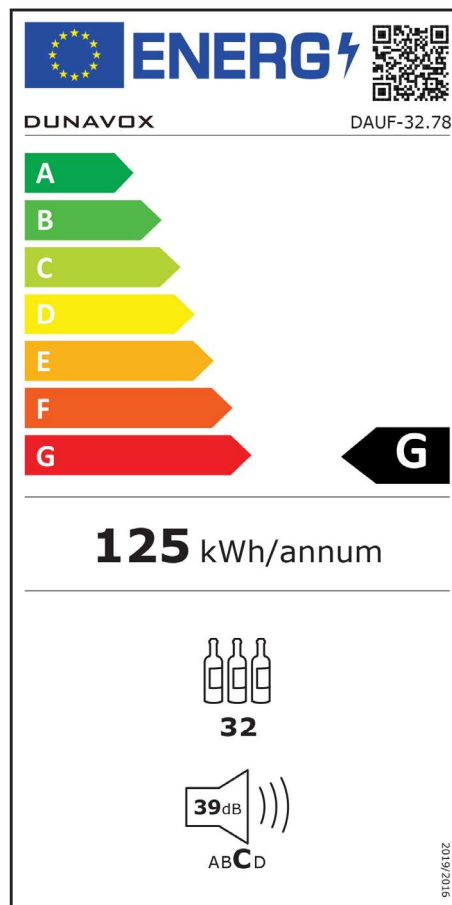

Installation drawing

