

**AVI60CDZA**  
**2-compartments service wine cabinet**  
**Built-in column range**



- + Capacity: 36 bottles\*:
  - upper part: 24 bottles
  - lower part: 12 bottles
- + Vinotag compatible\*\* 
- + Built-in column
- + Design: black body & black piano organic glass door frame
- + Cooling system: compressor
- + Type of cold: air moving system
- + Adjustable temperature ranges of use:
  - upper part: 5°-12°C
  - lower part: 12°-20°C
- + Electronic regulation
- + Thermometer with white electronic display
- + White LED lights with switch button
- + Humidity control: water tray
- + 1 reversible glass door, anti-UV treated, 3-layers tempered glass (grey-colored)

Cabinet that is installed in a **niche for** conventional built-in **oven**, characterized by its standard size: **60 H x 60 W cm**.

Thanks to **door and temperature alarms**, offer the best protection to your bottles of wine.

With the **demo mode**, reduce the energy consumption of your appliance. Only display and LED lights are active, ideal for expositions or fairs!



## Eco-responsibility

Our products are manufactured in compliance with European environmental rules. Especially, refrigerant fluid (R600a) doesn't reject neither CFC nor HFC and respect environment.

Energy consumption is calculated based on the result obtained for 24h in standard test conditions. The actual energy consumption depends on the conditions of use and location of the device.

This equipment is designed to be used in an ambient temperature between 16°-32°C.

This appliance is intended to be used exclusively for the storage of wine.

Alcohol abuse is dangerous for health, please consume in moderation.

\*Capacity given as an indication with 75cl Bordeaux traditional type bottles and measured with 2 shelves. Adding shelves reduce considerably the total capacity.

\*\*Thanks to the Vinotag® application, benefit from a digital register of your wine cellar and be alerted of the peak dates of your wines. In partnership with Vivino, scan your bottle to access its pre-filled wine sheet.

## AVI60CDZA 2-compartments service wine cabinet Built-in column range

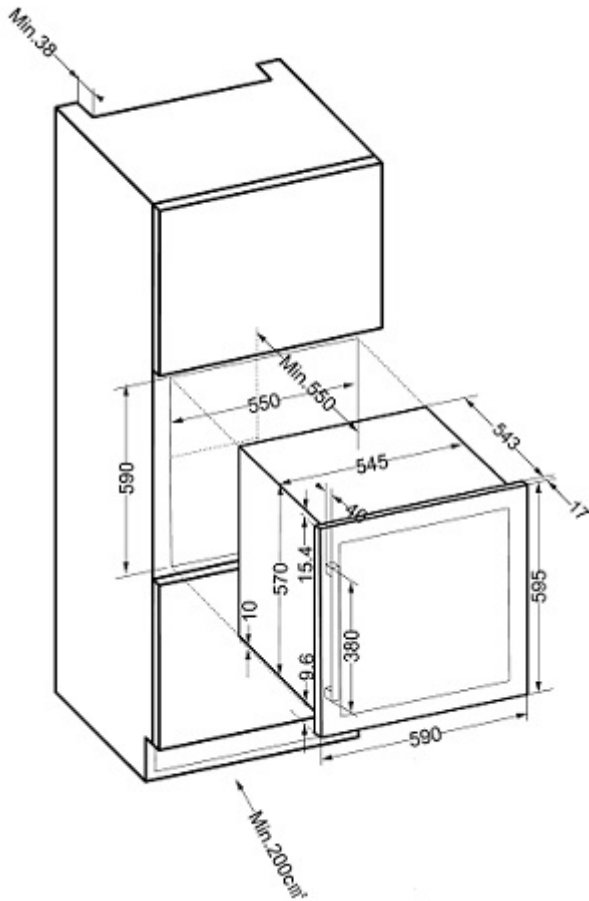

### > EQUIPMENTS INCLUDED

- 2 sliding wooden shelves (beech)
- 1 sliding wooden half-shelf (beech)
- 4 adjustable feet (height 1 cm)
- Anti-vibration system

### > TECHNICAL CHARACTERISTICS

- Energy class: G
- Annual electrical consumption: 142 kWh
- Climatic class: N
- Noise level: 39 dB
- EEI: 171.0
- Voltage: 220-240 V
- Power input: 60 W
- Category: 2 - Wine cellar
- Type of gas: R600a

### > SAFETY

- **Visual and audible alarms:** notify you when your attention is required

### > VINOTAG® APPLICATION

Free wine cellar management application. Access a virtual representation of your wine cellar and a detailed inventory of its contents.

### > LOGISTIC DATAS

Gross dimensions (WxDxH cm)	: 65,6 x 62 x 63,5
Net dimensions (WxDxH cm)	: 59 x 56 x 59,5
Gross weight (kg)	: 36.00
Net weight (kg)	: 33.00
Full truck (pcs)	: 120
Container (pcs)	20' : 81
	40' : 162
	40' HC : 216

Gencod 3595320105292

### > COMPATIBLE ACCESSORIES

Only available in spare parts