



- + Capacity: 52 bottles\*
- + Vinotag compatible\*\* 
- + Built-in column
- + Design: black body & stainless steel door frame
- + Cooling system: compressor
- + Type of cold: air moving system
- + Adjustable temperature ranges of use:
  - upper part: 5°-18°C
  - lower part: 5°-18°C
- + Electronic regulation
- + Thermometer with white electronic display
- + White LED lights with switch button
- + Humidity control: natural (hygrodynamic concept)
- + 1 reversible glass door, anti-UV treated, 3-layers tempered glass (grey-colored)

Opt for the **elegant design** of this cabinet which will fit perfectly into your kitchen and will keep your wines at a constant temperature.

Thanks to its both temperature zones, you could bring **simultaneously** your bottles at **room temperature** or bring them to **service temperature**.

\*Capacity given as an indication without presentation shelf. Adding shelves reduces considerably the total capacity.



## Eco-responsibility

Our products are manufactured in compliance with European environmental rules. Especially, refrigerant fluid (R600a) doesn't reject neither CFC nor HFC and respect environment.

Energy consumption is calculated based on the result obtained for 24h in standard test conditions. The actual energy consumption depends on the conditions of use and location of the device.

This equipment is designed to be used in an ambient temperature between 10°-32°C.

This appliance is intended to be used exclusively for the storage of wine.

Alcohol abuse is dangerous for health, please consume in moderation.

\*Capacity given as an indication with 75cl Bordeaux traditional type bottles and measured with 5 shelves. Adding shelves reduce considerably the total capacity.

\*\*Thanks to the Vinotag® application, benefit from a digital register of your wine cellar and be alerted of the peak dates of your wines. In partnership with Vivino, scan your bottle to access its pre-filled wine sheet.



**AVI47XDZA**  
**2-compartments service wine cabinet**  
**Built-in column range**

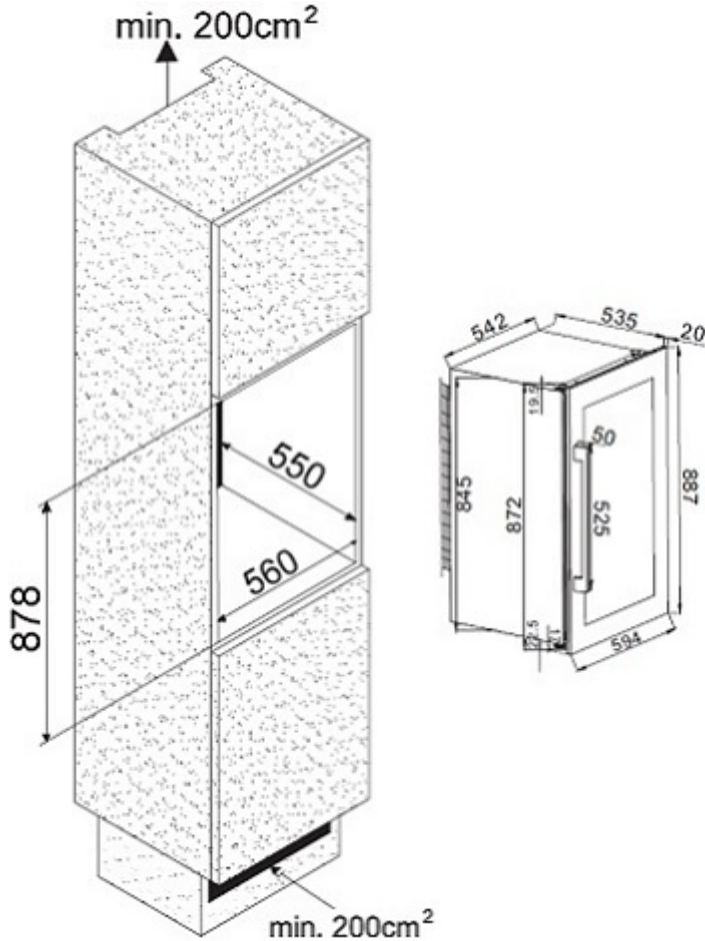

> EQUIPMENTS INCLUDED

- 4 semi-sliding wooden shelves (beech)
- 1 fixed wooden presentation shelf (beech)
- 2 adjustable feet (height 1 cm)
- Anti-vibration system

> TECHNICAL CHARACTERISTICS

- Energy class: G
- Annual electrical consumption: 162 kWh
- Climatic class: N-SN
- Noise level: 36 dB
- EEI: 188.0
- Voltage: 220-240 V
- Power input: 24 W
- Category: 2 - Wine cellar
- Type of gas: R600a

> SAFETY

- **Visual alarm:** notifies you when your attention is required

> VINOTAG® APPLICATION

Free wine cellar management application. Access a virtual representation of your wine cellar and a detailed inventory of its contents.

> LOGISTIC DATAS

Gross dimensions (WxDxH cm)	: 65 x 65 x 94
Net dimensions (WxDxH cm)	: 59,5 x 55,7 x 88,7
Gross weight (kg)	: 49.00
Net weight (kg)	: 45.00
Full truck (pcs)	: 120
Container (pcs)	20' : 54
	40' : 108
	40' HC : 148

Gencod 3595320105339

> COMPATIBLE ACCESSORIES

Only available in spare parts