

Floating Fountain with Lights *1/4 HP* *1/2 HP*

Operating instructions
Notice d'emploi
Instrucciones de uso



REMINDER
CALL 1-866-627-3435
BEFORE RETURNING TO STORE.

Part	Description	QTY
A	Floating Attachment Assembly with LED lights	1
B	Trumpet Nozzle	1
C	Single Tier Nozzle	1
D	3 Tier Nozzle	1
E	Nozzle adapter (1/4 HP only)	1
F	Coupler (1/4 HP only)	1
G	Transformer	1
H	Sensor	1
I	Pump with cord for LED light	1
J	Tether Line	1
K	Ground Anchor	3

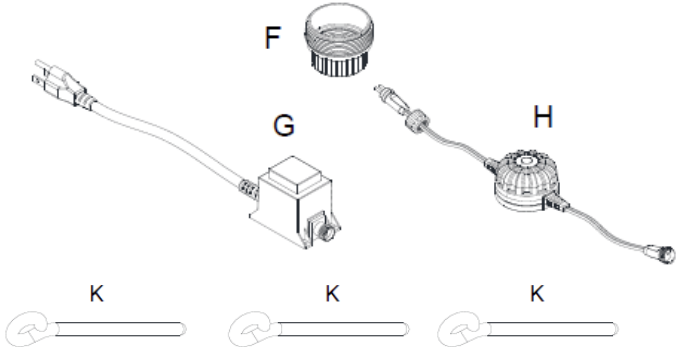
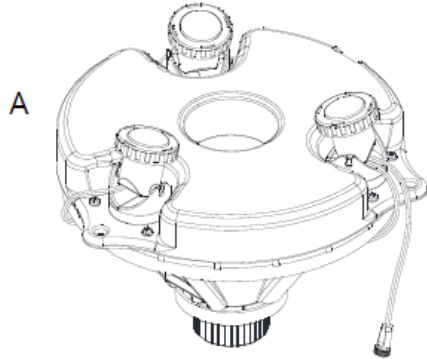
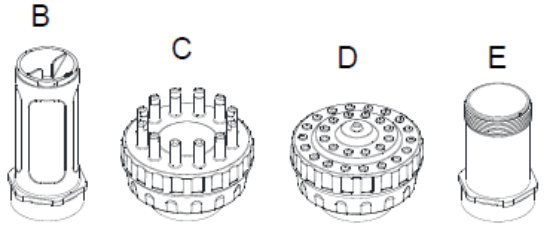

Information about these operating instructions

Welcome to OASE Living Water. You made a great choice with the purchase of this product **Floating Fountain with Lights 1/4 HP / 1/2 HP**. Prior to operating the unit, please read the instructions of use carefully and fully familiarise yourself with the unit. Ensure that all work on and with this unit is only carried out in accordance with these instructions. Please strictly follow the enclosed instructions to ensure safe and correct handling of the product. Keep these instructions in a safe place. Please also hand over the instructions when passing the unit on to a new owner.

WARNINGS AND CAUTIONS SYMBOLS

Symbols used in these instructions

The symbols used in this operating manual have the following meanings:

 Risk of injury to persons due to dangerous electrical voltage.
This symbol indicates an imminent danger, which can lead to death or severe injuries if the appropriate measures are not taken.

 Risk of personal injury caused by a general source of danger.
This symbol indicates an imminent danger, which can lead to death or severe injuries if the appropriate measures are not taken.

 Important! The unit is equipped with a permanent magnet. The magnetic field may affect the function of pacemakers.

 Important information for trouble-free operation.

Intended use

Floating Fountain with Lights 1/4 HP / 1/2 HP, referred to in the following as "unit", may only be used as specified in the following:

- For creating a water fountain in lakes or large ponds with or without fish.
- For aeration and supplying oxygen to lakes or ponds.
- Operation under observance of the technical data.

The following restrictions apply to the unit:

- Do not use in swimming pools.
- CAUTION - this pump has been evaluated for use with water only.
- Never run the unit without water.
- Do not use for commercial or industrial purposes.
- Operate in fresh water only. Avoid heavily chlorinated water and water with high pH levels.
- Do not use in conjunction with chemicals, foodstuff, easily flammable or explosive substances.
- Do not connect to the domestic water supply.
- Do not exceed the input voltage shown on the pump and transformer.
- Do not submerge the transformer and the sensor.
- Do not lift the pump, float assembly or the transformer by its power cord.

Use other than that intended

This unit can be dangerous and cause harm if not used in accordance with these instructions. Any use not in accordance with these instructions or modification(s) to the unit will void the limited warranty.

Questions, problems, missing parts?

Before returning to your retailer, call us at 1-866-627-3435, 8 a.m.-6 p.m., EST, Monday-Friday, or email us at customer-care@oase-livingwater.com. Or visit our website at www.oase-livingwater.com

Installation



WARNING

Risk of electric shock – This pump is supplied with a grounding conductor and grounding-type attachment plug. To reduce the risk of electric shock, be certain that it is connected only to a properly grounded, grounding-type receptacle. Do not remove the grounding pin from the power cord plug. Inspect cord for damage before installation and/or maintenance. Replace the entire fountain assembly if damage is found.

Always disconnect fountain from the power source before beginning any maintenance or work on the pump.

Important:

- Do not lift the pump by its power cord.
Use the handle to lift and maneuver the pump.
1. Remove assembled fountain from packaging and connect pump to floating attachment assembly.
 - For 1/4 HP, use the coupler to connect the pump.
 2. Choose a fountain head for the desired water effect, and assemble your choice.
 - For 1/4 HP, use the nozzle adapter.

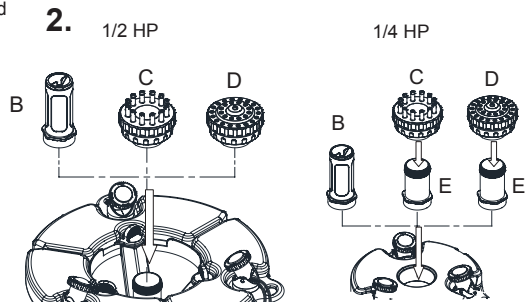
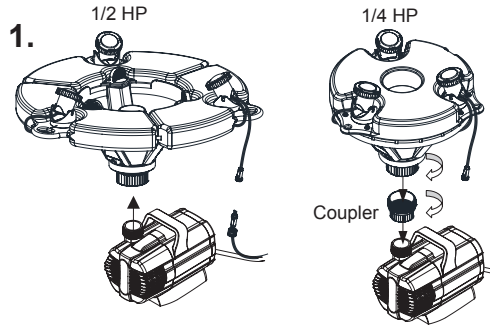

3. Connect the light to the cord (Part I) by pushing the plug into the light socket until it is firmly seated. Hand tighten the nut from the plug to the socket.

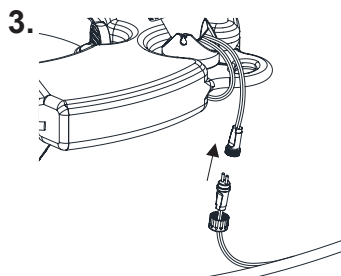

4. Connect the cord for LED light to the sensor by pushing the plug into the sensor socket until it is firmly seated. Hand tighten the nut from the plug to the socket.

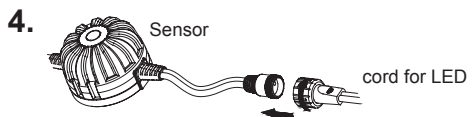

Installation (cont.)

5. Connect the sensor to the transformer by pushing the plug into the transformer socket until it is firmly seated. Hand tighten the nut from the plug to the socket.

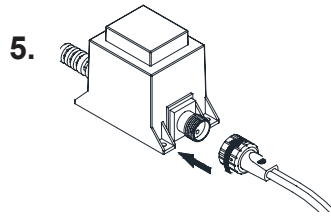

6. Use a knife to cut 3 pieces of tether Line, line length depends on your lake size, attach one side of each line to one of the three loops.

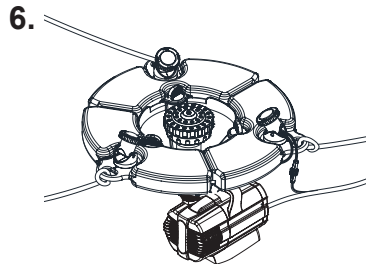

7. Place the fountain into the water and tether it with supplied line and ground anchors into desired location.

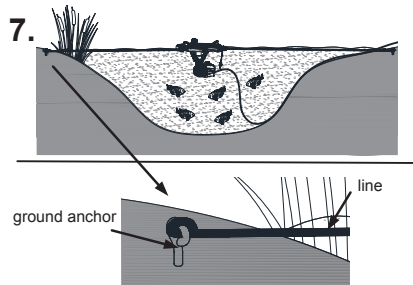

Start-up

⚠ Attention! The pump must never run dry.
Possible consequences: The pump will be destroyed.

Protective measures: Check the water level at regular intervals. Always place the unit below water level and make sure it is floating.

⚠ Attention! The installed temperature sensor automatically turns the pump off, if it is overloaded. The pump automatically switches on again once the motor has cooled down. **Risk of accident!**
Install the unit so that it is not exposed to direct sun radiation (max. 104 °F - 40 °C).

Important:

- The unit switches on automatically when power connection is established.
- The light is designed to turn on when it gets dark, and turn off when it gets light. To activate the light during daylight hours, cover the sensor.

1. **Switching on:** Connect power plugs to the socket.

2. **Switching off:** Disconnect the power plugs.

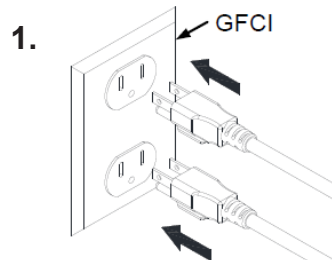

Questions, problems, missing parts?

Before returning to your retailer, call us at 1-866-627-3435, 8 a.m.-6 p.m., EST, Monday-Friday, or email us at customer-care@oase-livingwater.com. Or visit our website at www.oase-livingwater.com

Maintenance and cleaning



Attention! Dangerous electrical voltage.

Possible consequences: Death or serious injuries.

Protective measures:

- Electrical units and installations with a rated voltage of $U > 12 \text{ V AC}$ or $U > 30 \text{ V DC}$ located in the water: Isolate the units and installations (switch off and disconnect from the power supply) before reaching into the water.
- Isolate the unit before starting any work.
- Secure the unit to prevent unintentional switching on.



WARNING

This pump uses a very strong magnet to achieve superior performance. When removing the impeller assembly there will be considerable magnetic force resisting the extraction of the impeller assembly. This is normal. Likewise when replacing the impeller assembly there will be a strong magnetic force pulling the assembly into the pump to potentially cause injury to fingers and in rare cases damaging the ceramic shaft or rear bearing. Use thick gloves when replacing the impeller assembly.

Cleaning the unit

- Regular cleaning of the pump may be necessary depending upon the environment in which it is operated. Clean the fountain when a drop in visual performance is detected.
- If necessary, clean the unit with warm water using a soft brush.
- Never use aggressive cleaning agents or chemical solutions. These could attack the housing surface or impair the function.
- In the event of stubborn furring (calcium deposits), a common household cleaner free from vinegar and chlorine can be used. Subsequently, clean the pump thoroughly using warm water.

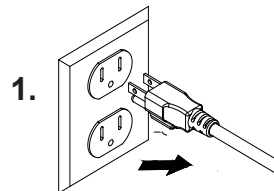

Cleaning the pump

1. Disconnect the pump and the transformer from the power source.
 - Disconnect the pump from the floating fountain.
 2. Remove the screen and disassemble the impeller housing to expose the impeller assembly.
 3. Remove the impeller assembly by pulling on the back round plate behind the impeller.
 4. Use a soft cloth or brush to clean the impeller assembly and the inside of the impeller housing.
- Check parts for damages such as cracked rotor, cracks in the magnet, and broken plastics. Replace parts if necessary.
5. Reassemble in the reverse order.

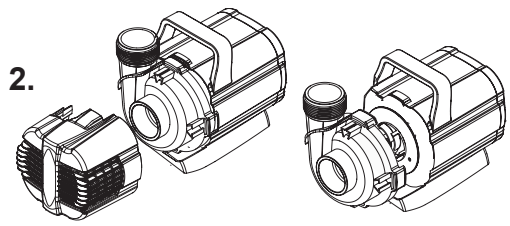

3.

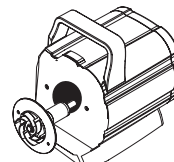

4.

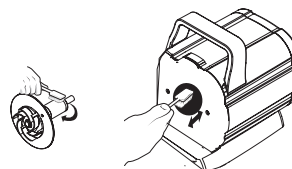

Storage/Winterization

- Put the unit out of operation at water temperatures below 46 °F (8 °C) or, at the latest, when freezing temperatures are to be expected.
- Thoroughly clean the unit, check for damage.
- Ensure that the storage place is inaccessible to children.

Wear parts

The impeller unit is a wear part and is excluded from the warranty.

Disposal



Do not dispose of this unit with domestic waste! Disable the unit beforehand by cutting off the cables. Further information about the recycling of this product can be obtained from your local municipal authority.

Troubleshooting

Issue	Cause	Solution
The unit is not performing its suction function	Power supply not connected	Connect pump to power supply, check the supply lines to make sure the voltage is correct
	Impeller blocked, shaft broken	Remove the inlet screen and/or pump cover, and impeller housing to expose the impeller. Turn the impeller to ensure that it is not broken or jammed by debris. Also check to make sure that the ceramic shaft or bearings are not broken.
	Pump is not completely submerged	Place the unit below water, make sure it is floating.
Insufficient flow	Pump screen clogged	Clean
	Pump is not completely submerged	Place the unit below water, make sure it is floating.
	Pump overload. The flow is automatically stopped to protect the pump.	<ul style="list-style-type: none"> ○ Clean the pump housing and impeller assembly ○ Reduce the ambient temperature (e.g. ensure that the specified water temperature is adhered to, avoid direct sunlight)
	Impeller assembly of pump worn	Replace impeller assembly for pump
	Nozzle clogged	Clean
Unit switches off after a short running period	Excessive soiled water	Clean impeller housing, bearing and impeller assembly
	Impeller blocked, shaft broken	Remove the inlet screen and/or pump cover, and impeller housing to expose the impeller. Turn the impeller to ensure that it is not broken or jammed by debris. Also check to make sure that the ceramic shaft or bearings are not broken.
	Water temperature too high	Maximum water temperature: +95° F (+35 °C)
Lights do not turn on	Power supply not connected	Connect transformer power supply, check the supply lines to make sure the voltage is correct
	Sensor blocked	Check that the sensor faces up and is not covered by dirt or debris

Questions, problems, missing parts?

Before returning to your retailer, call us at 1-866-627-3435, 8 a.m.-6 p.m., EST, Monday-Friday, or email us at customer-care@oase-livingwater.com. Or visit our website at www.oase-livingwater.com

Floating Fountain with Lights	Model	Model No.	Rated voltage	Power consumption	Max. flow rate	Max. head height	Dimensions	Weight
	1/4 HP	45383	120V / 60 Hz	130 W	2300 GPH	20 ft.	14.3 x 18.9 in.	14.96 lbs.
	1/2 HP	45393		230 W	5150 GPH	23 ft.	22.8 x 16.73 in.	19.25 lbs.



EN	Model	trumpet	single tier	3-Tier
Floating Fountain with Lights	1/4 HP	Adjustable 15.75 x 3.6 ft.	16 ft. x 10 ft.	6.5 x 10 ft.
	1/2 HP	Adjustable 23 ft. x 5 ft.	28 ft. x 12 ft.	9 ft. x 12 ft.

Floating Fountain with Lights	
Pos.	1/4 HP
1	Trumpet Nozzle
2	Single Tier Nozzle
3	3 Tier Nozzle
4	Nozzle adapter
5	Coupler
6	Transformer
7	Sensor
8	Pump with cord for LED light
9	Tether Line
10	Ground Anchor
11	LED light set
12	Light cord Extension
13	Float
14	Bolt
15	Washer 1
16	Washer 2
17	Screw 1
18	Fountain Support
19	Nut
20	Adapter
21	Locking ring
22	Screw 2
23	Screen
24	Impeller housing
25	Impeller Assembly
26	O-ring

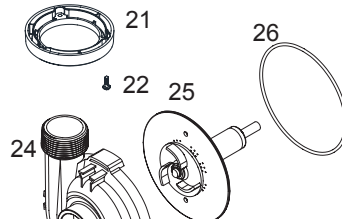
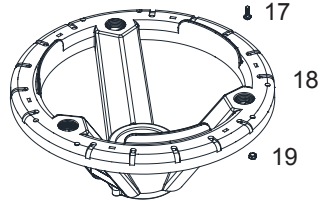
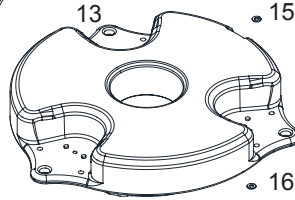
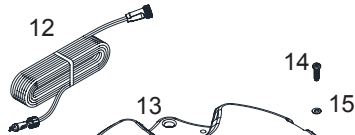
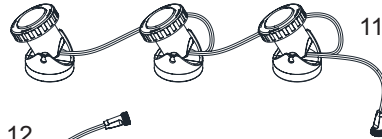
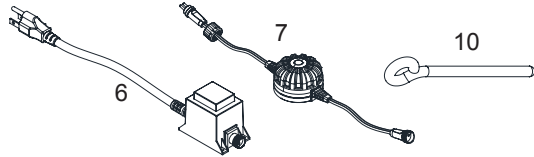
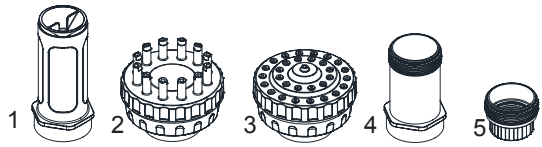

Pos.	Floating Fountain with Lights
	1/2 HP
1	Trumpet Nozzle
2	Single Tier Nozzle
3	3 Tier Nozzle
4	Transformer
5	Sensor
6	Pump with cord for LED light
7	Tether Line
8	Ground Anchor
9	LED light set
10	Light cord Extension
11	Float
12	Bolt
13	Washer 1
14	Screw 1
15	Fountain Support
16	Adapter
17	Locking ring
18	Screw 2
19	Screen
20	Impeller housing
21	Impeller Assembly
22	O-ring

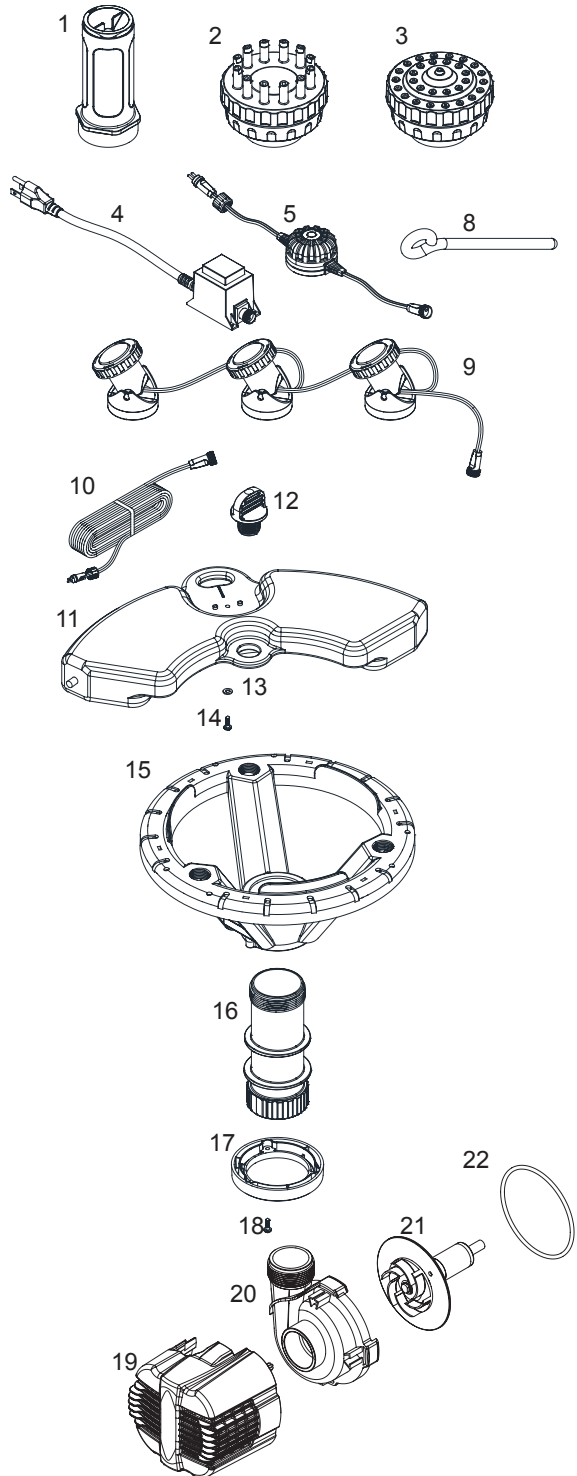



OASE North America INC. · www.oase-livingwater.com

47877/08-16