

# DreamPond ®

## KOITOILET I Aerated Bottom Drain

For Liner and Concrete Koi Ponds

# 3"

### INSTALLATION INSTRUCTION

#### Part List:

Part ID	Part Description	Qty
KTA-S	Drain Base	1
KTA-R	Liner Ring	1
KTA-CC	Center Column	1
KTA-D	Dome Cover	1
DD07	7" Fine Bubble Disc Diffuser	1
DD3C	3" Coupling	1
SS	Self Tapping SS Screws	10

#### **Bottom Drain Base Installation:**

##### 1. Bottom Drain Base Assembly:

Attach the shorter lip side of the provided 3" coupling to the drain base, followed by a 3" PVC (or ABS) pipe.

Attach 3/4" air supply line to the 3/4" socket at the bottom of the drain base using a proper PVC/ABS transition glue.

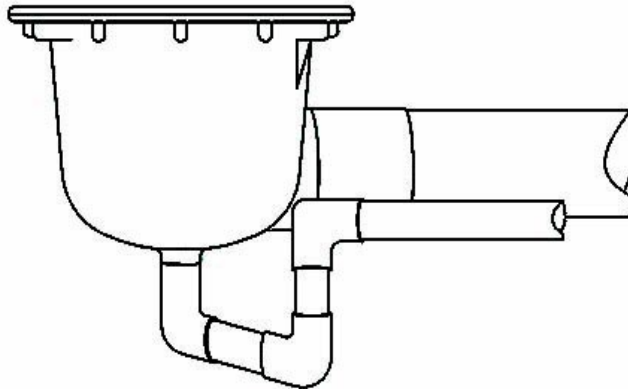

2. To get the most waste out of the pond, the bottom drain should be installed at the deepest location in the pond.

After deciding upon where to place the bottom drain, dig the hole that is at least 6" wider than the perimeter of the drain base and a trench for the plumbing.

3. Set the drain base and plumbing in the hole and trench. Use a leveler to check that the drain base and plumbing are leveled

4. Mix and pour concrete around the drain base and plumbing to secure the drain base in place. This will help prevent the drain base and plumbing from shifting when the pond is

filled with water. Wait at least 24 hrs for the concrete to dry before performing the next step.

5. Install the liner into position, ready for sealing onto the bottom drain. When you are satisfied that the liner is in place, locate the top flange through the liner. Place the liner ring in position and hold it steady as you cut a cross line into the liner inside the flange. From the opening of the cross cut, apply a layer of fish safe silicone (or polyurethane) sealant to the top flange of the drain, between the top flange and the liner. Make sure this is clean so you do not trap any dirt between the liner and the drain base.

6. Position the liner ring onto the liner so that it lines up with the flange of the drain base. Once the liner ring and flange are aligned, tighten the self tapping screws to secure the unit.

7. Once the liner ring has been secured to the drain, carefully cut away the excess portion of the liner inside the drain. Apply fish safe sealant around the drain body, liner and flange connection.

### **Dome Cover and Air Diffuser Installation:**

1. When installing the dome cover to the bottom drain, cut the center column to leave a  $\frac{1}{2}$ " to 1" gap between the liner and dome cover.
2. Screw the center column into the drain base (do not forget to use Teflon tape to prevent air from leaking out)
3. Glue the dome cover (with installed air diffuser) onto the center column.

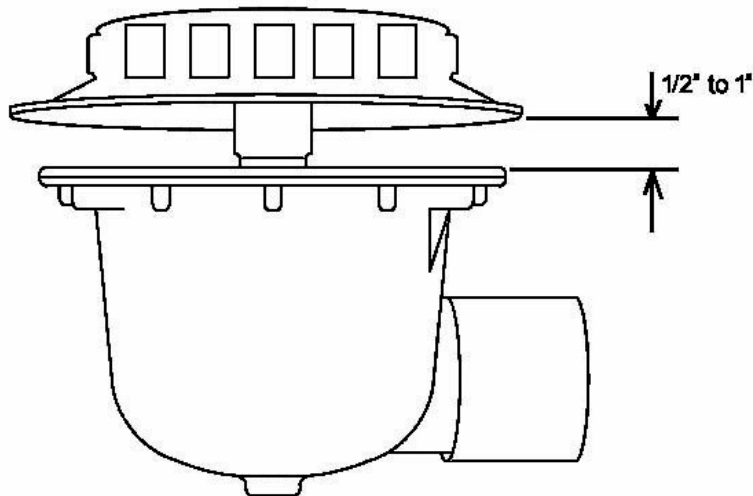

## **Air Diffuser:**

KoiToilet® I bottom drain incorporates a high quality FlexAir fine bubble air diffuser. Air Pump recommendation: 25 lpm – 40 lpm air pump per drain.

For multiple drains installation, air lines must be plumbed separately to avoid imbalanced air flow.

The FlexAir disc diffuser is provided with premium quality membrane materials that are engineered by EDI Membrane Technology division. EDI's proprietary membrane materials are engineered for superior product life.

Multiple membrane perforations are available to optimize the performance of the diffuser for maximum operating efficiency.

An integral triple check valve feature prevents the backflow of the liquid into the diffuser and piping.

The FlexAir disc diffuser is ideally suited for on/off applications and requires minimal maintenance for long term performance.

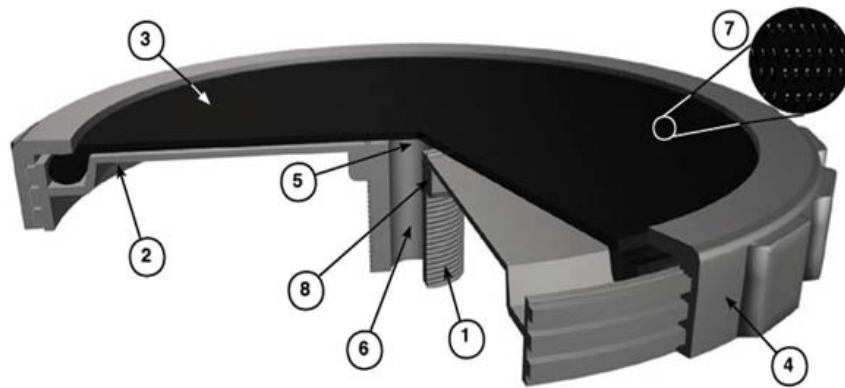

1. Threaded Connector 3/4 inch NPT (Male) Inlet
2. Diffuser Body
3. Flexible Membrane Media
4. Membrane Retainer Ring
5. Primary Check Valve Feature
6. Air Inlet Orifice
7. Die Cut Perforations
8. Hex Headed Shank

*Congratulations!*

*You are now finished installing the best aerated bottom drain to your pond system.*

***DreamPond.com***