



— *Manual* —

C-200 Controller



Installation Maintenance Repair Manual

Crystal Quest
55 Chastain Rd STE 100
Kennesaw, GA 30144
Phone: 800-934-0051

www.crystalquest.com
email: help@crystalquest.com

03/2023



C - 200 Controller Manual

Table of Contents

Contents	Page
I. Introduction	3
II. Model Numbering.....	4
III. Installation.....	5
Mounting	5
Power Wiring.....	5
Wiring Diagrams	6
I/O List.....	7
Switch Inputs.....	8
IV. System Operation	10
A. Operation	10
B. Calibration.....	15
C. Control Functions.....	15
V. Setpoints	16
A. Set Standard Setpoints.....	16
B. Differential Pressure Setpoints	17
C. Conductivity Setpoints	18
D. Flow Setpoints	18
E. Temperature Setpoints.....	19
F. pH/ORP Setpoints	10
G. Misc. Setpoints	21
VI. MODBUS Options / Settings.....	23

I. Introduction

The Crystal Quest Series 200 RO controller is a state of the art control system for commercial and industrial reverse osmosis systems. The C-200 combines features that have not previously been available in one compact unit.

The C-200 is a microprocessor-controlled system that can monitor multiple pressure sensors and/or pressure switches. A feed and permeate TDS/Conductivity monitor/controller with programmable setpoints is an integral part of the C-200. The C-200 displays system status and all sensor and switch input status on an easy to read backlit display. User-programmable setpoints are provided that allow fast and easy adjustment of system parameters.

Plug-in terminal strips allow easy wiring of all sensors and controls. The C-200 contains relays for control of an inlet valve, RO pump, flush valve, aux/boost pump, divert valve and an alarm output.

Sensor Inputs

C1 - Feed TOS/Conductivity - Standard: 0-2500, PPM/uS

Optional ranges: 50, 100, 500, 1000, 5000 or 10000 PPM/uS

C2 - Permeate TOS/Conductivity - Standard: 0-250, PPM/us

Optional ranges: 50, 100, 500, 1000, 2500, 5000 or 10000 PPM/uS

Pressure Sensors

P1 - Inlet pressure sensor

P2 - Feed pressure sensor

P3 - Pump pressure sensor

P4 - Concentrate pressure sensor

P5 - Misc. pressure sensor

Note: Pressure sensor range determined by sensors used.

Relay Outputs

Inlet control, 5A SPDT

RO pump control, 5A SPDT

Flush control, 5A SPDT

Aux/Boost pump control, 5A SPDT

Divert control, 5A SPDT

Alarm output, 5A SPDT

Note: Total maximum output for all relays is 20A.

Output voltage is voltage supplied to board.

Optional Sensors

F1 - Permeate flow meter

F2 - Concentrate flow meter

F3 - Recirculate flow meter

F4 - Misc. flow meter

Flow sensor range determined by sensors used.

pH1 - 0-12 pH

pH2 - 0-12 pH

ORP1 - 0-999mV

ORP2 - 0-999mV

II. Model Numbering

Build a Model

Model _____ - _____ - _____ - _____ - _____ - _____

Base Control Selection _____

C-200 = Inlet solenoid, flush time delay, pressure switch, two TDS sensors

S201 = Model S200 with four (4) flow meter input PCB

Controller Supply Voltage _____

1 = 120 VAC

2 = 220 VAC

3 = 120 VAC with UL labeling

4 = 220 VAC with UL labeling

Permeate Conductivity Scale _____

A = 0-50 PPM

D = 0-500 PPM

K = 0-100 uS

B = 0-100 PPM

E = 0-1,000 PPM

L = 0-250 uS

C = 0-250 PPM

J = 0-50 uS

M = 0-500 uS

N = 0-1,000 uS

Second Conductivity Scale _____

X = No conductivity

F = 0-2,500 PPM

M = 0-500 uS

A = 0-50 PPM

G = 0-5,000 PPM

N = 0-1,000 uS

B = 0-100 PPM

H = 0-9,999 PPM

P = 0-2,500 uS

C = 0-250 PPM

J = 0-50 uS

Q = 0-5,000 uS

D = 0-500 PPM

K = 0-100 uS

R = 0-9,999 uS

E = 0-1,000 PPM

L = 0-250 uS

Communications Type _____

0 = None

1 = Ethernet communications - Modbus TCP, EtherNet/IP

2 = Ethernet communications - Bacnet TCP, EtherNet/IP

3 = Serial communications (RS485) and Modbus TCP, EtherNet/IP

4 = Serial communications (RS485) and Bacnet TCP, EtherNet/IP

pH and ORP _____

X = No pH or ORP

A = Feed pH only, no probe

B = Feed ORP only, no probe

C = Feed pH and ORP, no probes

D = Feed & permeate pH, no probes

E = Permeate pH only, no probes

G = Feed pH only with probe

H = Feed ORP only with probe

J = Feed pH and ORP with probes

K = Feed & perm. pH with probes

L = Permeate pH only with probes

Enclosure _____

3 = 12"×10"×6" poly **5** = 16"×14"×8" poly

4 = 14"×12"×8" poly **9** = Enclosure defined in Motor Control model number, or no enclosure.



III. Installation

Mounting Instructions

Mount the C-200 in a convenient location on the RO equipment using the four mounting ears provided with the unit or the optional panel mounting bracket.

Power Wiring

AC power for the controller can be S5-265VAC, 50/60Hz. AC power for the unit is connected to terminal strip P1. Connect the ground wire of the AC power to the terminal labeled GND. For AC power with a neutral and hot wire, the hot wire connects to L 1 and the neutral wire connects to L2. For AC power with 2 hot wires, either wire can connect to L 1 and L2.

 CAUTION 	
1.	There are live circuits inside the controller even when the power switch on the front panel is in the OFF position. Never open the front panel without first disconnecting power from the outlet. Prewired controllers are supplied with an 8 foot, 18 AWG power cord with USA style plug. A #1 Phillips driver is required to open the front panel.
2.	Low voltage signal wires (probes, flow switch, water meter, etc.) should never be run in conduit with high voltage (like 115VAC) wires.
3.	Never attempt to land connections to the controller without first disconnecting power from the outlet.
4.	Do not block access to disconnect power during mounting and installation.
5.	The controller should be connected to its own isolated circuit breaker, and for best results, the ground should be a true earth ground, not shared. Any attempt to bypass the grounding will compromise the safety of users and property.
6.	The electrical installation of the controller must be performed by trained personnel only and conform to all applicable National, State and Local codes.
7.	Operation of this product in a manner not specified by the manufacturer may result in damage to equipment or persons.
8.	Avoid mounting in locations that expose the controller to direct sunlight, vapors, vibration, liquid spills or extreme temperatures; less than 0°F (-17.8°C) or greater than 120°F (50°C). EMI(electromagnetic interference) from radio transmissions and electric motors can also cause damage or interference and should be avoided.

Terminal Strips and Connectors

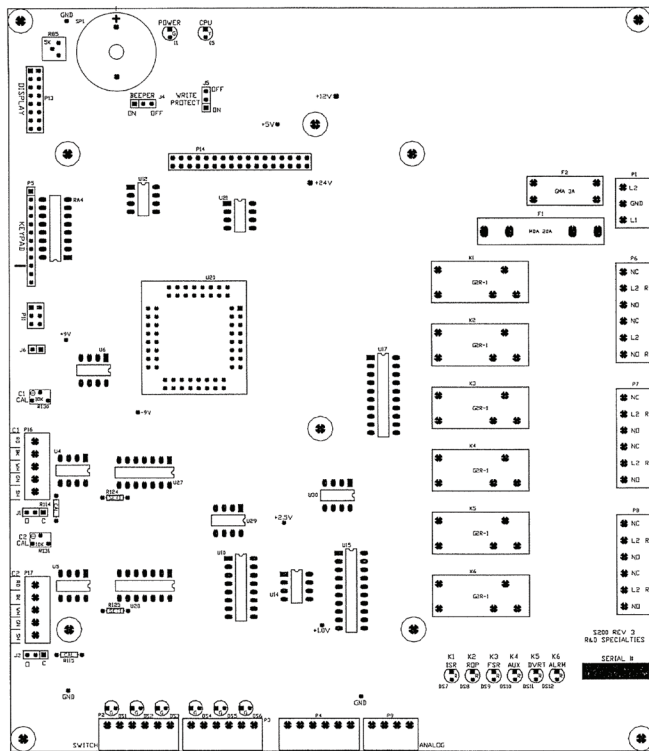

NOTES:

1. High voltage wiring should not be run in the same conduit as sensor and control wiring.
2. The switch inputs are dry contact only. Connecting power to these inputs will damage the controller.
3. The supply voltage to the board is the voltage that is output from the relays.

Jumper and Adjustment Locations

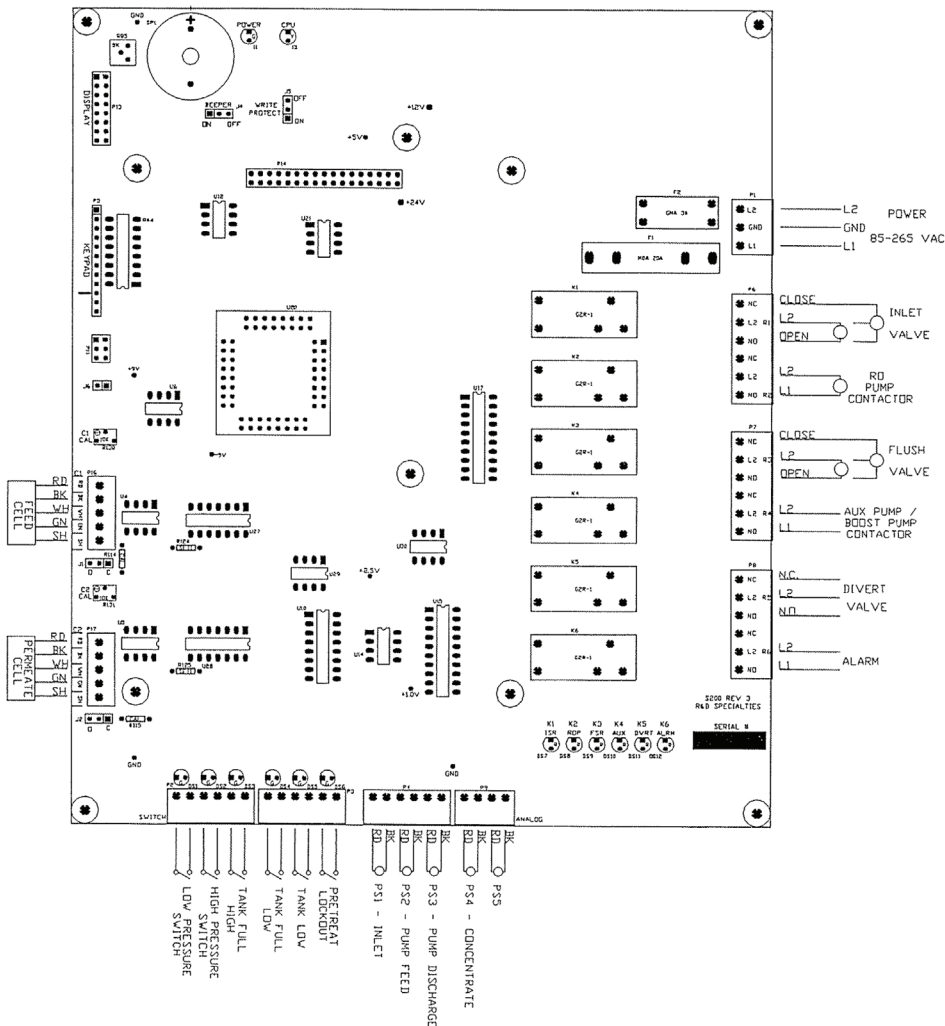

I/O List

The following table is a list of the inputs and outputs on the main board. The list shows the reference name for each input or output, the description and the terminals strip number/ pin connections.

Output	Description	Connection
R1	Inlet Valve	P6, 4-6
R2	RO Pump	P6, 1-3
R3	Flush Valve	P7, 4-6
R4	Aux/Boost Pump	P7, 1-3
R5	Divert Valve	P8, 4-6
R6	Alarm	P8, 1-3

Input	Description	Connection
S1	Lo PSI Switch	P2, 1-2
S2	Hi PSI Switch	P2, 3-4
S3	Tank Full High	P2, 5-6
S4	Tank Full Low	P3, 1-2

Input	Description	Connection
S5	Tank Low	P3, 3-4
S6	Pretreat Lockout	P3, 5-6

Conductivity	Description	
C1	Feed	P16
C2	Permeate	P17

Temperature	Description	
T1	Feed Temperature	Part of C1

Pressure	Description	
P1	Inlet	P4, 1-2
P2	Pump Feed	P4, 3-4
P3	Pump Discharge	P4, 5-6
P4	Concentrate	P9, 1-2
P5	Misc.	P9, 3-4

Pump and Valve Relay Outputs

The C-200 supplies relay outputs to control pump and solenoid valves.

NOTE: The relays output the same voltage as the AC power supplied to the board. If the solenoids operate on a different voltage, a relay will need to be added to operate the valves.



WARNING: The pump relay outputs cannot operate motor loads directly. A contactor must be supplied to operate a pump.

Pump Wiring

The RO pump contactor connects to NO and L2 of R2, terminals 1-2 of P6. If an auxiliary pump or boost pump is used, the contactor for the aux/boost pump will connect to NO and L2 of R4, terminals 1-2 of P7.

Valve Wiring

Solenoid valves or motor valves can be operated by the controller. All valves must operate at the same voltage as the controller unless an external control relay is used.

The inlet valve connects to NO and L2 of R1, terminals 4-5 of P6. If a motor valve is used, the common connection is connected to L2, the open connection connects to NO and the close connection connects to NC of R1, terminals 4-6 of P6.

The flush valve connects to NO and L2 of R3, terminals 4-5 of P7. If a motor valve is used, The common connection is connected to L2, the open connection connects to NO and the close connection connects to NC of R3, terminals 4-6 of P7.

The divert valve connects to NO and L2 of R5, terminals 4-5 of PS. If a motor valve is used, the common connection is connected to L2, the open connection connects to NO and the close connection connects to NC, terminals 4-6 of PS.

Alarm Wiring

An alarm output is available at terminals 1-3 of P8. This output supplies the same voltage as is supplied to the board.

Switch Inputs

The connections for the switch inputs are not polarity sensitive and can be connected to either terminal. The switches connect to P2 or P3 as required. Refer to page 6 for a sample wiring diagram. The switch input can be programmed as either normally open or normally closed in any combination. The switch connected to an input that is configured as normally open must be open for the unit to run. The switch connected to an input that is configured as normally closed must be closed for the unit to run. The Switch Select setpoint (119) allows each input to be configured as normally open or normally closed. The Switch Select setpoint is defaulted to 0 which programs all inputs as normally open. This means that all switch inputs must be open for the unit to run. The table below lists the values used to program the Setpoint to configure the inputs.

SWITCH	N.O.	N.C.	VALUE
S1 LOW PRESSURE	0	1	
S2 HIGH PRESSURE	0	2	
S3 TANK FULL HIGH	0	4	
S4 TANK FULL LOW	0	8	
S5 TANK LOW	0	16	
S6 PRETREAT LOCKOUT	0	32	
		TOTAL	

Select the type of switch used for each input and put that number in the value column. Add the values and program the total in the Switch Select Setpoint. For example, if S1 and S3 inputs were normally closed and all others normally open, the value programmed in the Switch Select Setpoint would be 5(1 + 4).

TDS / Conductivity Cell Wiring

For accurate TDS / Conductivity readings, the cell should be installed in a tee fitting where a continuous flow of water passes over the cell and no air can be trapped around the cell. Refer to the figure below for example installation and page 6 for wiring. The feed cell is connected with 5 wires to terminal strip P16. The permeate cell is connected with 5 wires to terminal strip P17. Connect each colored wire to the terminal labeled with the same color.

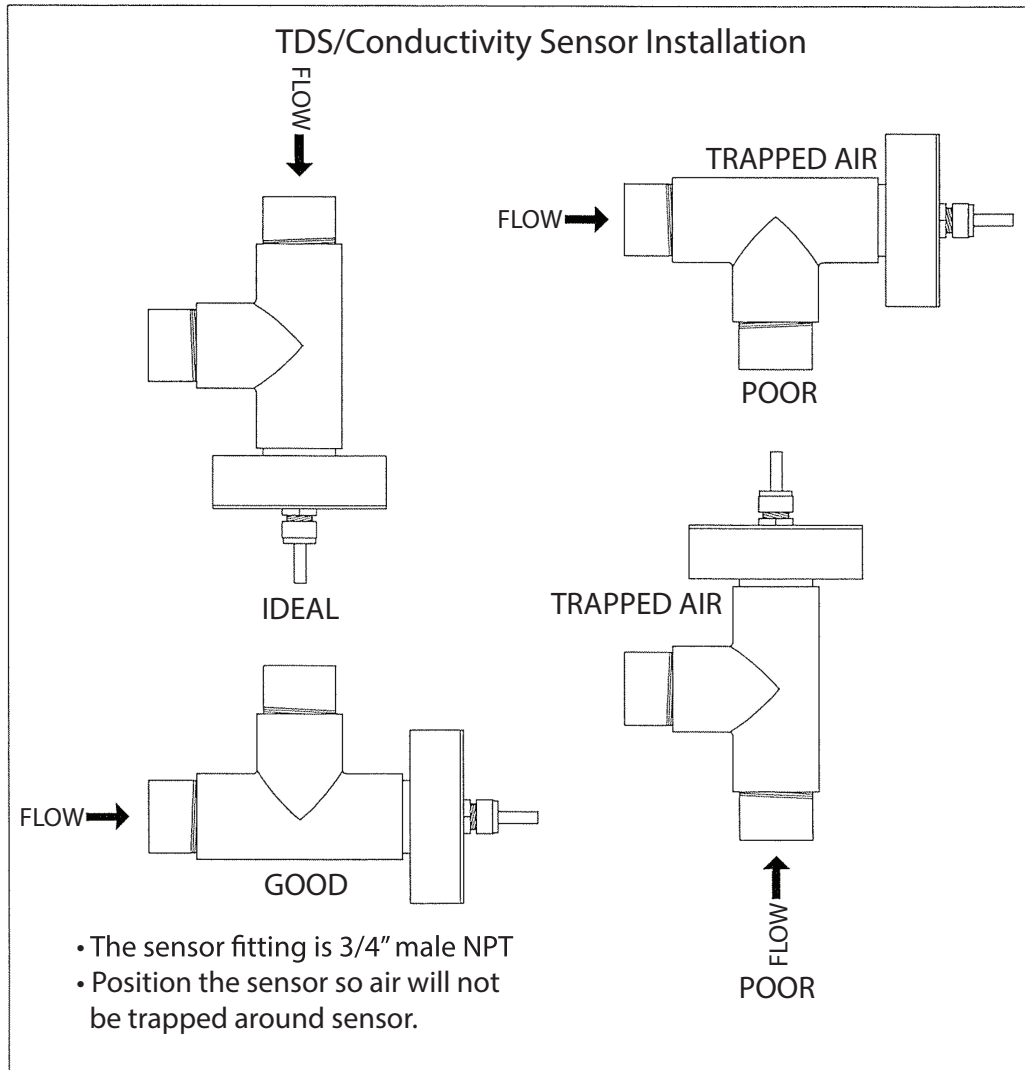

Pressure Sensor Wiring

Optional 2-wire 4-20mA pressure sensors can be connected to the controller. Refer to the figures on page 6 for terminals strip locations and a sample wiring diagram. The controller supplies 24VDC to operate the sensors.

IV. System Operation

A. Operation

The C-200 has 2 modes of operation: a standby mode and an operating mode. In the standby mode, the unit is effectively off. All output relays are turned off and the display shows STANDBY. In the operating mode, the unit operates automatically. All inputs are monitored and the outputs are controlled accordingly. Pressing the Power key will toggle the unit from standby to operate or from operate to standby. If power is removed from the unit, when power is reapplied, the unit will restart in the mode it was in when power was removed.

NOTE: If the Aux Mode setpoint is set to 0, the Auxiliary pump relay will not be affected by the Power switch.



WARNING: When the controller is in the standby mode, power is still applied to the unit and the relay outputs may still have voltage on them. To service the unit, power should be removed from the controller.

Display

The display is a 4 line x 20 character backlit liquid crystal display. System operating status, warnings and sensor readings are shown on the display. Setpoint information is also shown on the display when the setpoint mode is active.

Screens

System status, warnings and sensor readings are displayed by selecting from 3 different screens. Toggle through the screens by pressing the Display key.

Screen 1 shows the operating status on the top line. All shutdown alarms will show on this line in addition to operation status messages. This screen also displays the following sensor readings: C1 (feed), C2 (permeate), % rejection, P2 (pump inlet), P3 (pump discharge) and T1 (feed temperature).

The top line of screen 2 will display multiple items. If no warnings are active, the top line will cycle through the current date/time, operating hours, P5, pH1, pH2, ORP1 and ORP2, dependent on what sensor are used. If any warnings are active, they will be included in the cycling of the display. This screen also displays the following sensor readings: P1 (inlet), P2 (pump feed), P1-P2 differential pressure, P3(pump discharge), P4 (concentrate) and P3-P4 differential pressure.

Screen 3 displays the following flow sensor data: F1 (permeate), F1 total, F2 (concentrate), F2 total, F3, F4 and % recovery.

RO Operation

On startup of the RO unit, the inlet relay will operate and after the RO Delay (106), the RO pump relay will operate. The RO unit will continue to operate until a condition occurs that causes a shutdown. This can be a normal operating condition or an alarm condition. For either condition, the top line of screen 1 will display the reason for the shutdown. If the condition is due to an alarm, the alarm lamp will flash and the audible alarm will sound.

Tank Full

The C-200 can be operated with 1 or 2 level switches. With 1 level switch, the switch is connected to the tank full high input. When this switch has been active for the Tank Full Delay (107), the unit will shut down on tank full. TANK FULL will show on the display. When the tank full condition clears, the display will show TANK FULL 99. The number is the Tank Full Restart (108) time and the unit will restart when this delay times out.

For 2 level switch operation, the upper switch is connected to the tank full high input and the lower switch is connected to the tank full low input. When both switches are clear, the RO unit will run. The RO unit will continue to run when the water level rises and the lower switch becomes active. When the upper switch becomes active, after the Tank Full Delay (107), the RO unit will shut down. TANK FULL will show on the display. When the tank level drops and the upper level switch clears, the display will show TANK FULL 99 and the RO unit will remain off. The number is the Tank Full Restart(108) time and the number will blink until the lower level switch clears. When the lower level switch clears, the number will remain steady and will begin to count down and the RO will restart when the delay times out.

Tank Full Override

A timed Tank Full Override(109) can be initiated when the RO unit is shut down due to a tank full condition. Pressing Function, 1 and the Enter key during a tank full condition will enable the tank full override. The RO will start and TF OVERRIDE 9 will show on the display. The number is the minutes remaining in the override timer. When the override times out, the unit will return to the tank full shut down condition.

Pretreat Lockout

When the pretreat lockout input becomes active for the time programmed in the Pretreat Delay (112) setpoint, the unit will shutdown and PRETREAT LOCKOUT will show on the display. When the pretreat lockout input clears, the unit will restart.

Pressure Sensor Warnings / Alarms

A low/high pressure limit is enabled by programming the limit to a value other than 0. Whether the limits generates a warning or an alarm is determined by the setting of the warning/shutdown setpoint for each sensor. Refer to the pressure sensor setpoints section of the manual for further information.

If a low or high pressure warning limit is exceeded, the alarm lamp will light steady and the warning will be shown on screen 2. The RO unit will continue to operate.

If a low or high pressure shutdown is enabled for any pressure sensor and the limit is exceeded for the sensor for the delay programmed for the sensor, the unit will shutdown for a pressure alarm condition. The sensor causing the alarm will be shown on screen 1, the alarm lamp will flash and the audible alarm will sound. Pressing the Alarm Silence/Reset key twice will reset the alarm.

Low Pressure Switch Alarm

If the low pressure switch input becomes active for the the delay programmed in the Lo PSI Sw Delay (125), the unit will shutdown for a low pressure switch alarm. LO PRESSURE will show on the display, the alarm lamp will flash and the audible alarm will sound. The alarm can be reset by pressing the Alarm Silence/Reset key twice.

High Pressure Switch Alarm

If the permeate TDS / Conductivity reading exceeds the limit programmed the C2 Limit Setpoint for the delay programmed in the C2 Delay Setpoint, the alarm lamp will light and the HI Cond 2 warning message will show on the display. This warning will clear when the TDS / Conductivity drops below the Setpoint. If the Shutdown Delay Setpoint is programmed to 0, the unit will continue to operate. Otherwise, once a high TDS / Cond warning occurs, after the time programmed in this setpoint, the RO unit will shut down and the alarm will sound. The alarm can be cleared by pressing the Alarm Silence/Reset key twice.

High Pressure Switch Alarm

If the high pressure switch input becomes active for the the delay programmed in the Hi PSI Sw Delay (126), the unit will shutdown for a high pressure switch alarm. HI PRESSURE will show on the display, the alarm lamp will flash and the audible alarm will sound. The alarm can be reset by pressing the Alarm Silence/Reset key twice.

Conductivity Sensor Warning / Alarm

A high conductivity warning can be enabled by programming the conductivity limit setpoint to a value other than 0. If the warning is enabled and the conductivity is above the limit for the time programmed in the delay setpoint, the alarm lamp will light steady and the warning will be shown on screen 2.

A high conductivity shutdown is enabled for a conductivity sensor when the shutdown delay is programmed to a delay greater than 0. When the limit is exceeded for the sensor for the shutdown delay, the unit will shutdown for a conductivity alarm condition. The sensor causing the alarm will be shown on screen 1, the alarm lamp will flash and the audible alarm will sound. Pressing the Alarm Silence/Reset key twice will reset the alarm.

Auto Reset

If the pretreat input becomes active and stays active for 2 seconds, the unit will shut down in a pretreat lockout condition. PRETREAT will show on the display and the unit will remain shut down as long as the pretreat input is active.

Alarm Silence

When an alarm condition occurs, the audible alarm can be silenced by pressing the Alarm Silence/Reset key once. The condition is not cleared unless the key is pressed a second time. If the Alarm Silence (115) setpoint is programmed to 0, the alarm will remain silenced. Otherwise, the alarm will resound after this delay times out.

Auxiliary Pump Control

If the Aux Mode (127) setpoint is programmed to 0, relay 4 is programmed to operate as a auxiliary (repressurization) pump control. The relay will normally be on at all times. If the tank low input becomes active for the time programmed in the Tank Low Delay (110) setpoint, the relay will turn off. The alarm lamp will light steady and TANK LOW will show on screen 2. Once the tank low input clears, the relay will remain off for the number of minutes programmed in the Tank Low Restart(111) delay setpoint. The relay will then turn on, the alarm lamp will turn off and the warning will be removed from screen 2.

Boost Pump Control

If the Aux Mode (127) setpoint is programmed to 1, relay 4 is programmed to operate as a boost pump control. The relay will turn on when the RO starts and will turn off when the RO stops. If the tank low input becomes active for the time programmed in the Tank Low Delay (110) setpoint, the RO unit will shutdown. TANK LOW will show on screen 1, the alarm lamp will flash and the audible alarm will sound. Pressing the Alarm Silence/Reset key will reset the alarm.

Divert

When the C2 limit is enabled and the C2 reading is above the limit, the divert relay will be activated. This will occur immediately with no delay. When the C2 reading drops below the limit, the divert relay will remain active for the time programmed in the Divert Delay(113) setpoint. After the delay times out, the divert relay will turn off.

Membrane Flush

If the Flush Type (121) setpoint is programmed to 0, flush is disabled. If membrane flush is desired, several types of flush are available. When the unit enters a flush cycle, the flush relay will activate. The flush cycle will last for the time programmed in the Flush Time (123) setpoint. The table below shows the value that must be programmed in the Flush Type setpoint for each type of flush.

Flush Type	Description
0	NO FLUSH
1	TANK FULL
2	OPERATING HOURS
3	OPERATING HOURS AND TANK FULL
4	ELAPSED TIME
5	ELAPSED TIME AND TANK FULL
6	OFF HOURS
7	OFF HOURS AND TANK FULL
8	RO START/STOP

TANK FULL - The RO unit will flush each time a tank full condition occurs.

OPERATING HOURS - A flush will occur when the RO pump has operated for the number of hours programmed in the Flush Interval Setpoint.

ELAPSED TIME - A flush will occur after the number of hours programmed in the Flush Interval Setpoint has passed.

OFF HOURS - A flush will occur when the RO has been shut down due to a tank full condition for the number of hours programmed in the Flush Interval Setpoint.

RO START/STOP - A flush will occur each time the RO starts or stops.

The tank full flush can be combined with any of the 3 internal flush types. A manual flush can be initiated using Function 2

Flush Mode

The Flush Mode Setpoint can be used to control the operation of the inlet valve and RO pump during flush. Each can be independently programmed to operate during flush. The table shows the values to program into the Flush Mode Setpoint to control the operation of the inlet and RO outputs during flush.

Flush Mode	RO Pump	Inlet Valve
0	OFF	CLOSED
1	OFF	OPEN
2	ON	CLOSED
3	ON	OPEN

Flow Metering

If the optional flow metering board is installed, up to 4 flow sensors can be monitored by the controller. The flow board is mounted on the main board. Each flow meter requires 3 connections: Power (+), signal (SIG) and ground (GND). For magnetic pickup sensors such as a Signet 515, the jumper for the meter should be in the B position. For sensors that require power, the jumper for the sensor should be moved to the A position. The K-Factor as supplied from the sensor manufacturer should be entered in the Span setpoint for each installed meter.

Terminal Strips for Connecting Flow Meters

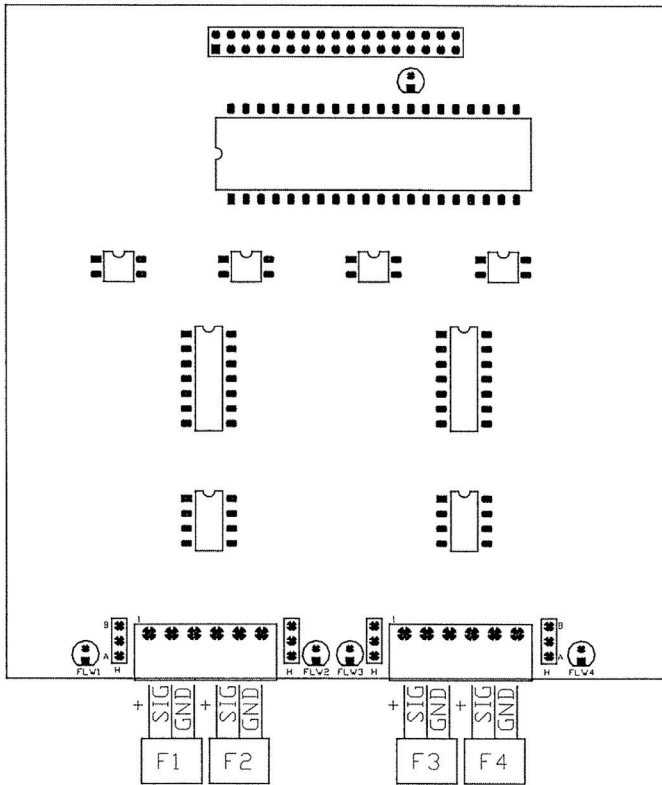

Terminal Strips for Connecting Sensors

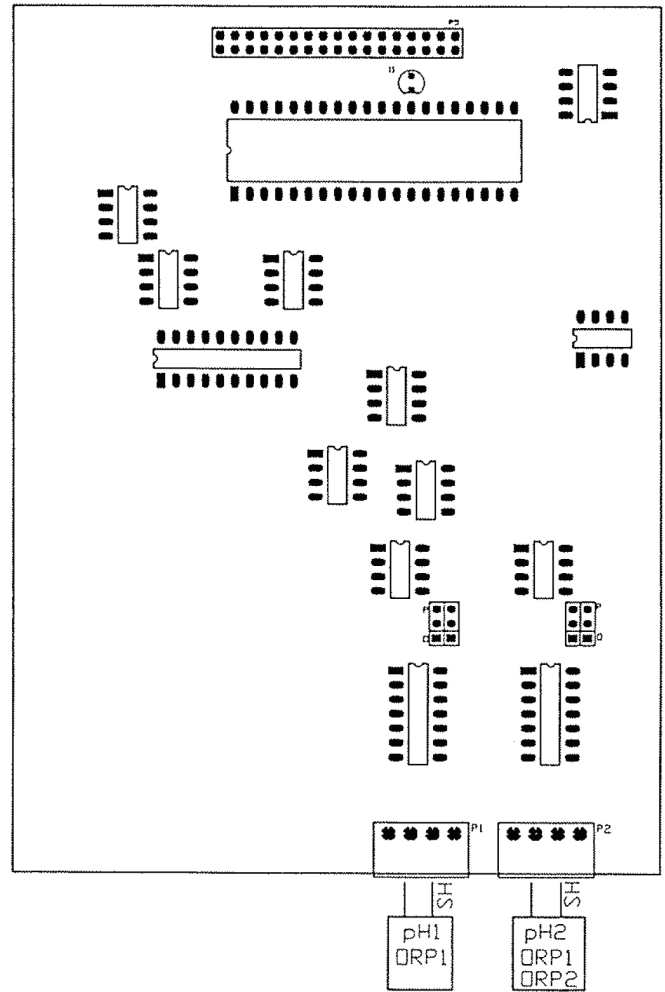

pH / ORP

If the optional pH/ORP board is installed, pH and/or ORP sensors can be monitored. The pH/ORP board is mounted to the main board. The controller can monitor pH and ORP sensors as determined by the setting of the pH/ORP Select(086) setpoint. Refer to the table for the sensor configuration. If a sensor is not selected, the reading for the sensor will not be shown.

pH/ORP Select	pH1	pH2	ORP1	ORP2
0	NO	NO	NO	NO
1	YES	NO	NO	NO
2	NO	NO	YES	NO
3	YES	NO	YES	NO
4	YES	YES	NO	NO
5	NO	NO	YES	YES

Refer to the figures on page 14 for the location of the terminal strips for connecting the sensors. The Terminal strips are 4 pin connections. The sensors connect to pins 2 and 3. The shield wire of the sensor connects to pin 3 and the signal wire connect to pin 2. To set a channel for pH, the 2 jumpers in the channel must be in the UPPER position. To set a channel for ORP, the 2 jumpers in the channel must be in the DOWN position. To calibrate the sensors, refer to the calibration section of the manual.

B. Calibration

Pressure Calibration

The pressure sensors have no calibration adjustments. Minor adjustments to zero and span can be made using the offset and span setpoints.

Flow Calibration

The flow sensors have no calibration adjustments. Adjustments to the span can be made using the span setpoint.

Conductivity Calibration

Each conductivity channel has an onboard span adjustment. The span adjustment is located adjacent to the connector for the cell for each channel. The C1 adjustment is R130 and the C2 adjustment is R131. Refer to page 6 for the location of the adjustments for each sensor.

Note: You will need to move the J5 jumper on the back of our boards to the C pin before calibrating the unit. Once it is calibrated, return the jumper to its previous position between the C and O pin.

The conductivity can be calibrated by measuring the conductivity with a known good meter and adjusting the span adjustment for the channel to display the same reading.

pH Calibration

- **To calibrate pH1** - Place the pH cell in a pH 4 buffer and allow the cell to stabilize for several minutes. Press Function, 5 and Enter to calibrate the system to the pH 4 buffer. Remove the pH cell and rinse in distilled water and place in a pH 7 buffer and allow to stabilize for several minutes. Press Function, 6 and Enter to calibrate the system to the pH 7 buffer and complete the calibration procedure.
- **To calibrate pH2** - Place the pH cell in a pH 4 buffer and allow the cell to stabilize for several minutes. Press Function, 7 and Enter to calibrate the system to the pH 4 buffer. Remove the pH cell and rinse in distilled water and place in a pH 7 buffer and allow to stabilize for several minutes. Press Function, 8 and Enter to calibrate the system to the pH 7 buffer and complete the calibration procedure.

ORP Calibration

To calibrate the ORP sensor, connect a voltage source supplying 750mV to the terminals of the ORP sensor to be calibrated. If there is only 1 ORP sensor, Press Function, 7 and Enter to calibrate ORP1. If there are 2 sensors, press Function, 5 and Enter to calibrate ORP1 or press Function, 7 and Enter to calibrate ORP2 . Disconnect the voltage reference and connect the ORP cell.

C. Control Functions

Function 1 - TANK FULL OVERRIDE - Allows the RO unit to run for a timed period during a tank full condition by pressing the Function key, 1 and the Enter key.

Function 2 - MANUAL FLUSH - If flush is enabled, allows a flush cycle to be manually initiated by pressing the Function key, 2 and the Enter key. If flush is already active, pressing the Function key, 2 and the Enter key will end the flush.

Function 4 - CLOCK PROGRAMMING - The clock time is programmed by pressing the Function key, 4 and then entering the current time, date and then pressing the Enter key. The time is entered in military format HHMM and the date is entered as MMDDYY.

Function 5 - pH1 4 BUFFER/ ORP1 CALIBRATE - If pH1 is enabled, Function 5 is used to calibrate the pH sensor to a pH 4 buffer. For further details, refer to the pH section of the manual. If ORP1 and ORP2 are enabled, Function 5 is used to calibrate the ORP1 sensor. For further details, refer to the ORP section of the manual.

Function 6 - pH1 7 BUFFER - If pH 1 is enabled, Function 6 is used to calibrate the pH sensor to a pH 7 buffer. For further details, refer to the pH section of the manual.

Function 7 - pH2 4 BUFFER/ ORP1 CALIBRATE/ ORP2 CALIBRATE - If pH2 is enabled, Function 7 is used to calibrate the pH sensor to a pH 4 buffer. For further details, refer to the pH section of the manual. If only ORP1 is enabled, Function 7 is used to calibrate the ORP sensor. If ORP1 and ORP2 are enabled, Function 7 is used to calibrate the ORP2 sensor. For further details, refer to the ORP section of the manual.

Function 8 - pH2 7 BUFFER - If pH 2 is enabled, Function 8 is used to calibrate the pH sensor to a pH 7 buffer. For further details, refer to the pH section of the manual.

V. Setpoints

A. Set Standard Setpoints

SETPOINT	DESCRIPTION	RANGE	DEFAULT
001	PS1 LO	0000-9999	0000
002	PS1 HI	0000-9999	0000
003	PS1 DELAY	000-999	005
004	PS1 WARNING/SHUTDOWN	0-3	0
005	PS1 OFFSET	00-99	50
006	PS1 SPAN	0000-9999	0307
007	PS2 LO	0000-9999	0000
008	PS2 HI	0000-9999	0000
009	PS2 DELAY	000-999	005
010	PS2 WARNING/SHUTDOWN	0-3	0
011	PS2 OFFSET	00-99	50

SETPOINT	DESCRIPTION	RANGE	DEFAULT
012	PS2 SPAN	0000-9999	0307
013	PS3 LO	0000-9999	0000
014	PS3 HI	0000-9999	0000
015	PS3 DELAY	000-999	005
016	PS3 WARNING/SHUTDOWN	0-3	0
017	PS3 OFFSET	00-99	50
018	PS3 SPAN	0000-9999	0615
019	PS4 LO	0000-9999	0000
020	PS4 HI	0000-9999	0000
021	PS4 DELAY	00-999	005
022	PS4 WARNING/SHUTDOWN	0-3	0
023	PS4 OFFSET	00-99	50
024	PS4 SPAN	0000-9999	0615
025	PS5 LO	0000-9999	0000
026	PS5 HI	0000-9999	0000
027	PS5 DELAY	000-999	005
028	PS5 WARNING/SHUTDOWN	0-3	0
029	PS5 OFFSET	00-99	50
030	PS5 SPAN	0000-9999	0615

B. Differential Pressure Setpoints

A differential pressure warning is enabled when the limit is programmed to a value other than 0000. DP1 is P1-P2. DP2 is P3-P4. A warning will be generated when the pressure exceeds the limit for the number of seconds programmed in the delay.

SETPOINT	DESCRIPTION	RANGE	DEFAULT
035	DP1 LIMIT	0000-9999	0000
036	DP1 DELAY	0000-9999	0030
037	DP2 LIMIT	0000-9999	0000
038	DP2 DELAY	0000-9999	0030

C. Conductivity Setpoints

There are 5 setpoints for each conductivity input. The limit setpoint sets the value of the high conductivity alarm for the input. If set to 0000, the limit is disabled. When the limit is enabled, the delay setpoint is the time in seconds before a warning is generated. The shutdown limit is the delay in seconds before a conductivity shutdown occurs. If set to 000, the conductivity shutdown is disabled. The offset setpoint allows the O level of the input to be adjusted. Setting the offset to 00 or 50 provides no offset to the reading. A setting above 50 adds an offset to the reading and a setting below 50 subtracts an offset from the reading. The exact offset is determined by the span setting. The span setpoint sets the full scale reading of the input. The span is calculated by dividing the full scale range of the sensor by 1.024 and entering the whole number as the setpoint. For example, a setpoint of 2441 would be entered for a 2500uS range ($2500/1.024 = 2441$).

SETPOINT	DESCRIPTION	RANGE	DEFAULT
041	CS1 LIMIT	0000-9999	0000
042	CS1 DELAY	0000-999	030
043	CS1 SHUTDOWN	000-999	000
044	CS1 OFFSET	00-99	50
045	CS1 SPAN	0000-9999	2441
046	CS2 LIMIT	0000-9999	0000
047	CS2 DELAY	000-999	030
048	CS2 SHUTDOWN	000-999	000
049	CS2 OFFSET	00-99	50
050	CS2 SPAN	0000-9999	0244
051	CS2 HIGH RANGE	0-1	0

D. Flow Setpoints

There are 4 setpoints for each flow input. The LO and HI limit setpoints set the value of the flow alarms for the input. The limits are 4 digits with the fourth digit being tenths. If 1234 is entered as the setpoint, the limit is set to 123.4. If set to 0000, the limit is disabled. When a limit is enabled, the delay setpoint is the time in seconds before a warning is generated. The span setpoint is a 6 digit number that sets the full scale reading of the input. The 5th and 6th digits of the span are tenths and hundredths. The span is the K-factor as supplied from the flow sensor manufacturer.

SETPOINT	DESCRIPTION	RANGE	DEFAULT
056	FS1 LO LIMIT	0000-9999	0000
057	FS1 HI LIMIT	0000-9999	0000
058	FS1 DELAY	000-999	030
059	FS1 SPAN	000000-999999	100000

SETPOINT	DESCRIPTION	RANGE	DEFAULT
060	FS2 LO LIMIT	0000-9999	0000
061	FS2 HI LIMIT	0000-9999	0000
062	FS2 DELAY	000-999	030
063	FS2 SPAN	000000-999999	100000
064	FS3 LO LIMIT	0000-9999	0000
065	FS3 HI LIMIT	0000-9999	0000
066	FS3 DELAY	000-999	030
067	FS3 SPAN	000000-999999	100000
068	FS4 LO LIMIT	0000-9999	0000
069	FS4 HI LIMIT	0000-9999	0000
070	FS4 DELAY	000-999	030
071	FS4 SPAN	000000-999999	100000
072	TOTALIZER 1	00000000-99999999	00000000
073	TOTALIZER 2	00000000-99999999	00000000

E. Temperature Setpoints

A temperature alarm is enabled when the limit is programmed to a value other than 000. An alarm will be generated when the temperature exceeds the limit for the number of seconds programmed in the delay. The temperature offset setpoint allows the temperature reading to be adjusted a few degrees up or down. Programming the setpoint to 5 gives no adjustment. Lowering the offset decreases the temperature reading. Increasing the offset increases the temperature reading.

SETPOINT	DESCRIPTION	RANGE	DEFAULT
081	TEMP LIMIT	000-999	000
082	TEMP DELAY	00-99	010
083	TEMP OFFSET	0-9	5
084	TEMP U OM	0-F / 1-C	0

F. pH/ORP Setpoints

SETPOINT	DESCRIPTION	RANGE	DEFAULT
086	pH/ORP SELECT - Enables display of the installed pH/ORP sensors. If set to 0, all displays are disabled.	0-5	0
087	pH1 LO WARNING - Sets limit for pH1 low warning. If set to 0, warning is disabled.	00.00-14.00	0000
088	pH1 HI WARNING - Sets limit for pH1 high warning. If set to 0, warning is disabled.	00.00-14.00	0000
089	pH1 LO SHUTDOWN - Sets limit for pH1 low alarm. If set to 0, alarm is disabled.	00.000-14.00	0000
090	pH1 HI SHUTDOWN - Sets limit for pH1 high alarm. If set to 0, warning is disabled.	00.00-14.00	0000
091	pH1 DELAY - pH must exceed limit for this delay before alarm is activated.	00-99 sec.	10
094	pH2 LO WARNING - Sets limit for pH2 low warning. If set to 0, warning is disabled.	00.00-14.00	0000
095	pH2 HI WARNING - Sets limit for pH2 high warning. If set to 0, warning is disabled.	00.00-14.00	0000
096	pH2 LO SHUTDOWN - Sets limit for pH2 low alarm. If set to 0, alarm is disabled.	00.00-14.00	0000
097	pH2 HI SHUTDOWN - Sets limit for pH2 high alarm. If set to 0, warning is disabled.	00.00-14.00	0000
098	pH2 DELAY - pH must exceed limit for this delay before alarm is activated.	00-99 sec.	10
100	ORP1 HI WARNING - Sets limit for ORP high warning. If set to 0, warning is disabled.	000-999 mV	000
101	ORP1 HI SHUTDOWN - Sets limit for ORP high alarm. If set to 0, warning is disabled.	000-999 mV	000
102	ORP1 DELAY - ORP must exceed limit for this delay before alarm is activated.	0-99 sec.	10
103	ORP2 HI WARNING - Sets limit for ORP high warning. If set to 0, warning is disabled.	000-999 mV	000
104	ORP2 HI SHUTDOWN - Sets limit for ORP high alarm. If set to 0, warning is disabled.	000-999 mV	000
105	ORP2 DELAY - ORP must exceed limit for this delay before alarm is activated.	0-99 sec.	10

G. Misc. Setpoints

SETPOINT	DESCRIPTION	RANGE	DEFAULT
106	RO RELAY - When start signal is received delay before RO pump starts.	0000-9999 sec.	0005
107	TANK FULL DELAY - Delay before the RO shuts down due to a tank full condition.	00-99 sec.	05
108	TANK FULL RESTART - Delay before RO starts after a tank full condition clears.	0000-9999 sec.	0005
109	TANK FULL OVERRIDE - Time system will run when tank full override is initiated.	0-9 min.	5
110	TANK LOW DELAY - Delay before a tank low signal is valid.	00-99 sec.	05
111	TANK LOW RESTART - Delay before system restarts after a tank low condition clears.	0-99 min.	15
112	PRETREAT LOCKDOWN DELAY - When the pretreat in put is active, the delay before the RO shuts down.	00-99 sec.	05
113	DIVERT DELAY - Sets time divert will remain active after a high conductivity condition has cleared.	00-99 sec.	05
114	AUTO RESET - When a shutdown condition occurs, delay before system automatically resets. When set to 00, Auto Reset is disabled.	00-99 sec.	05
115	ALARM SILENCE - When the Alarm Silence button is pressed, the alarm will resound after this delay. If set to 000, the alarm will remain silenced.	000-999 sec.	300
116	MAX HOURS - If the current hours exceed this value, an Op Hours Exceeded warning is generated. If set to 00000, this warning is disabled.	00000-99999	00000
117	CURRENT HOURS - The current operating hours.	00000-99999	00000
118	LOG INTERVAL - Selects data logging interval. If set to 0, logging is disabled.	00-99 hrs.	00
119	SWITCH SELECT 1 - Programs switch inputs on main board as N.O. or N.C. Default is all normally open.	000-225	000
120	UNIT NUMBER - Sets unit number to identify unit logging data.	00-99	01
121	FLUSH TYPE - Selects the type of flush for the RO unit. If set to 0, flush is disabled.	0-8	0

SETPOINT	DESCRIPTION	RANGE	DEFAULT
122	FLUSH MODE - Determines the operation of the inlet valve and RO pump during flush.	0-4	0
123	FLUSH TIME - Length of flush cycle.	00-99 min.	05
124	FLUSH INTERVAL - Selects the interval between flushes when an interval type of flush is selected.	00-99 hrs.	24
125	LO PSI DELAY - Delay before an active low pressure switch will cause a shutdown.	00-99 sec.	05
126	HI PSI SW DELAY - Delay before an active high pressure switch will cause a shutdown.	00-99 sec.	05
127	AUX MODE - If set to 0, relay 4 operates as auxiliary pump control. If set to 1, relay 4 operates as a boost pump control.	0-1	0
128	SA1 - Selects active sensors for data logging.	000-255	000
129	SA2 - Selects active sensors for data logging.	000-255	000
130	SA3 - Selects active sensors for data logging.	000-255	000
131	SA4 - Selects active sensors for data logging.	000-255	000
132	UOM - Selects unit of measure for data logging. warning. If set to 0, warning is disabled.	000-255	000

VI. MODBUS Options / Settings

Baud Rate: 38400, 8, N, 1

Node Name: Mb_Srv

Node ID:10

Default IP: 192.168.1.24

The module is defaulted to Node 10 and a baud rate of 38400,8, N, 1.

The node address can be changed by changing the position of the switches on the 8 switch dipswitch. The switches have the following values.

SWITCH	VALUE
1	1
2	2
3	4
4	8
5	16
6	32
7	64
8	128

Turn on the switches whose values total the desired node address. The default value of node 10 has switch 2 and 4 on ($2 + 8 = 10$).

The 4 position dip switch allows the baud rate to be selected. The following table shows the baud rate values.

BAUD	SW4	SW3	SW2	SW1
NOT USED	OFF	OFF	OFF	OFF
110	OFF	OFF	OFF	OFF
300	OFF	OFF	ON	OFF
600	OFF	OFF	ON	ON
1,200	OFF	ON	OFF	OFF
2,400	OFF	ON	OFF	ON
4,800	OFF	ON	ON	OFF
9,600	OFF	ON	ON	ON
19,200	ON	OFF	OFF	OFF
20,833	ON	OFF	OFF	ON
28,800	ON	OFF	ON	OFF
38,400	ON	OFF	ON	ON
57,600	ON	ON	OFF	OFF
76,800	ON	ON	OFF	ON
115,200	ON	ON	ON	OFF

NOTE: If any of the DIP switches are changed, power to the module must be cycled for the changes to be implemented.

NOTE: Not all objects are used on all units. All values are float.

Object Name	Description	Address	Object Type	Units*
PS01	Pressure Sensor 1	40001	AV	PSI
PS02	Pressure Sensor 2	40003	AV	PSI
PS03	Pressure Sensor 3	40005	AV	PSI
PS04	Pressure Sensor 4	40007	AV	PSI
PS05	Pressure Sensor 5	40009	AV	PSI
CS01	TDS/Cond Sensor 1	40011	AV	uS/PPM
CS02	TDS/Cond Sensor 2	40013	AV	uS/PPM
TS01	Temperature Sensor 1	40015	AV	F
TS02	Temperature Sensor 2	40017	AV	F
FS01	Flow Sensor 1	40019	AV	GPM/LPM
FS02	Flow Sensor 2	40021	AV	GPM/LPM
FS03	Flow Sensor 3	40023	AV	GPM/LPM
FS04	Flow Sensor 4	40025	AV	GPM/LPM
PH01	pH Sensor 1	40027	AV	pH
PH02	pH Sensor 2	40029	AV	pH
DP01	Differential Pressure 1	40031	AV	PSI
DP02	Differential Pressure 2	40033	AV	PSI
FT01	Flow Total 1	40035	AV	GAL/LTR
FT02	Flow Total 2	40037	AV	GAL/LTR
HR01	Operating Hours	40039	AV	HRS
ORP1	ORP Sensor 1	40041	AV	mV
ORP2	ORP Sensor 2	40043	AV	mV
STAT1	System Status	40045	AV	Table
WRN1	Warnings	40047	AV	Table

*The unit of measure for some objects is based on the programming of the span setpoint or calibration for the sensor.

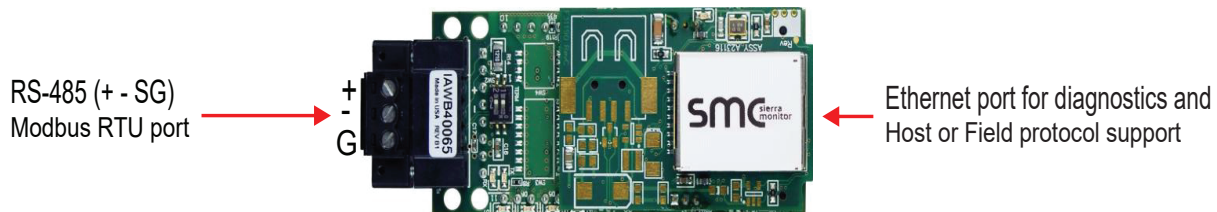

Status Table

VALUE	DESCRIPTION	VALUE	DESCRIPTION
0	RO OFF	35	CS1 HI
1	RO ON	36	CS2 HI
2	TANK FULL	39	PH1 LO
3	FLUSH	40	PH1 HI
4	PRETREAT	41	PH2 LO
5	CIP	42	PH2 HI
6	TANDBY	43	TANK LOW
11	PS1 LO	48	LO PRESS SWITCH
12	PS1 HI	49	HIGH TEMP
13	PS2 LO	57	ORP1 HI
14	PS2 HI	58	HI PRESS SWITCH
15	PS3 LO	59	
16	PS3 HI		
17	PS4 LO		
18	PS4 HI		
19	PS5 LO		
20	PS5 HI		

Warning Table

VALUE	DESCRIPTION	VALUE	DESCRIPTION
0	NO WARNINGS	33	F21 LO
1	PS1 LO	34	FS1 HI
2	PS1 HI	35	FS2 LO
3	PS2 LO	36	FS2 HI
4	PS2 HI	37	FS3 LO
5	PS3 LO	38	FS3 HI
6	PS3 HI	39	FS4 LO
7	PS4 LO	40	FS4 HI
8	PS4 HI	45	OP HOURS HI
9	PS5 LO	46	TANK LOW
10	PS5 HI	52	LOW % REJECTION
25	CS1 HI	53	ORP HI
26	PH1 LO	54	DP1 HI
29	PH1 HI	56	
31	PH2 LO		
32	PH2 HI		

- Notes -

Get the Advantage in Water Treatment Equipment

Crystal Quest can give you the *Advantage* in products, knowledge and support on all of your water treatment equipment needs.

- Cooling Tower Controllers
- Boiler Blow Down Controllers
- Blow Down Valve Packages
- Bleed Valves
- Water Meters
- Metering Pumps
- Corrosion Coupon Racks
- Solution Tanks
- Solid Feed Systems
- Bypass Feeders
- Filter Equipment
- Glycol Feed Systems
- Pre-Fabricated Systems

