



Water Softener System

SPECIFICATIONS

Approx. Capacity	450,000 Grains
Tank Material	Fiberglass
Backwash	Automatic
Media Type	Cation Resin
Media Amount	1,275 lbs.
Gravel (Quartz)	250 lbs.
Shipping Weight	1,597 lbs.
Space Required	L 85" x W 41" x H 95"

SYSTEM FLOWRATES

GALLONS PER MINUTE*

Service Flow	75 GPM
Peak Flow	140 GPM
Backwash Flow	25 GPM

STANDARD LINE/PORT SIZES

Inlet/Outlet	2"
Drain Port	1"
Brine Port	3/8"
Neck Opening	4"

COMPONENT LIST

1	2900 Control Head	CQE-CV-02900
2	Top Distributor	CQE-PT-03105
3	Water Softener Tank	CQE-CO-02047
4	Eaglesorb Media	CQE-RM-05002
5	Bottom Distributor	CQE-PT-03417
6	Center Riser Tube	CQE-PT-03417A
7	Bottom Distributor	CQE-PT-03417B
8	Quartz Support Bed	CQE-RM-05004
9	---	---
10	---	---

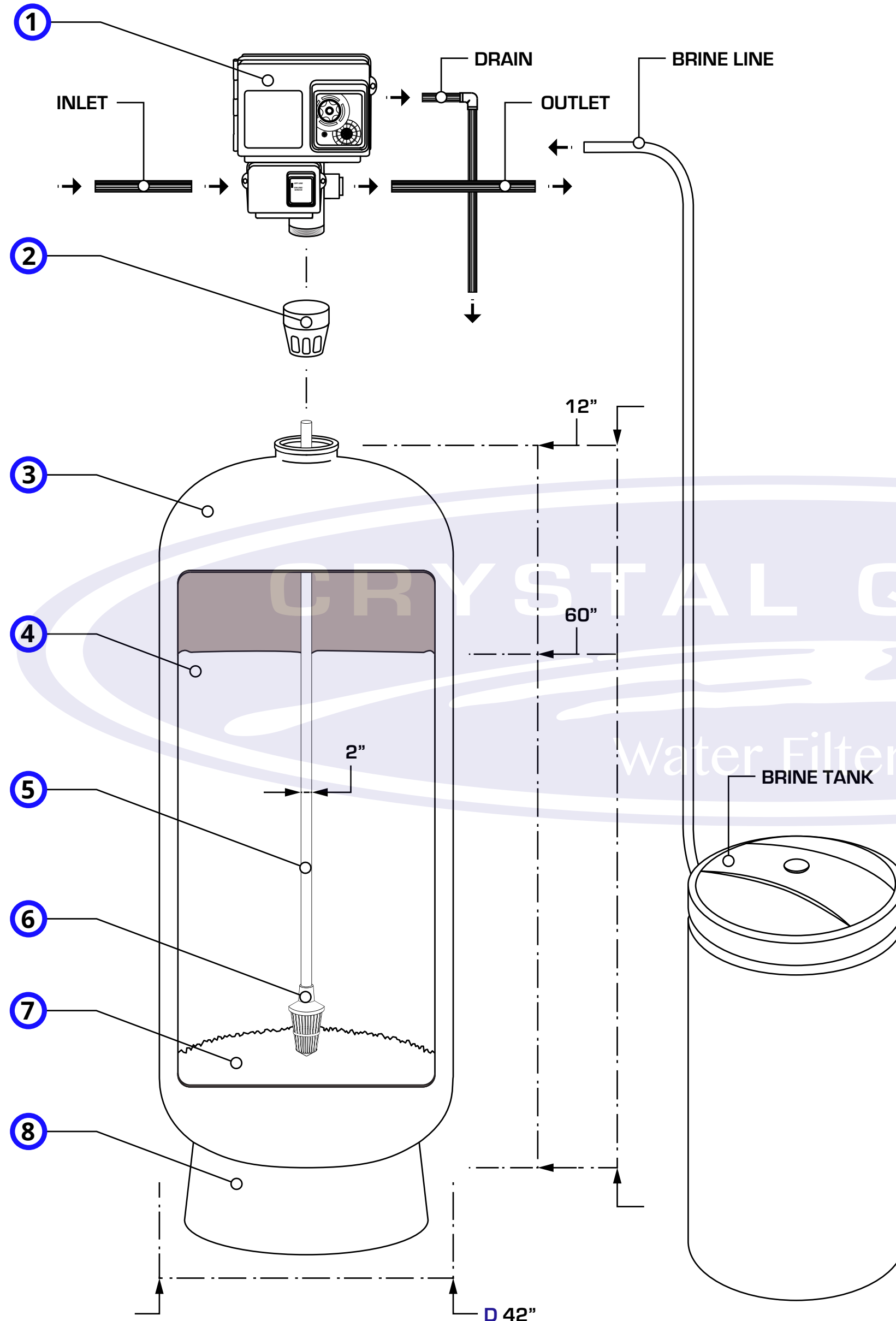

FLOW KEY

Influent Water Flow	
Filtered Water Flow	
Waste Water Flow	
Backwash Flow	

EXAMPLE FLOW DIAGRAM

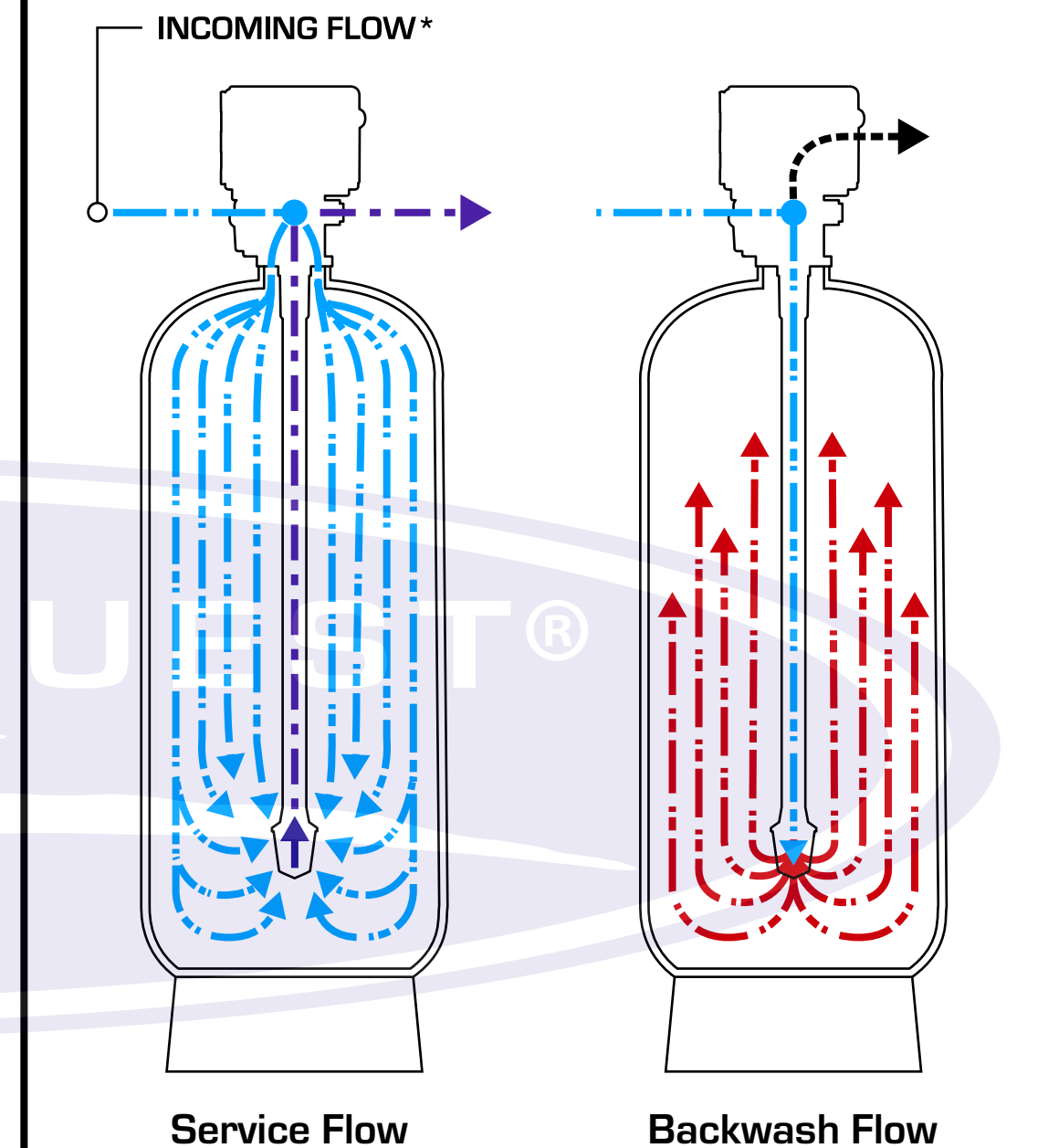

MEDIA SPECIFICATIONS

	Name	Eaglesorb Softener
	SKU	CQE-RM-05002
	Density	30 lbs per cu. ft.

CERTIFICATIONS



PHYSICAL CHARACTERISTICS

Approx. Color	Brown/Gold
Density Per Cu Ft.	85 lbs.
Granular Surface Area	12 x 40 Mesh

ORDER OF OPERATION: PRODUCT SKU: DIMENSIONS: COMMENTS:

75 GPM WATER SOFTENER	CQE-CO-02047	D 30" x H 72"	<ul style="list-style-type: none"> FLOOR DRAIN IS OPTIONAL. CONNECTIONS ARE 1" STANDARD UNLESS REQUESTED OTHERWISE.
COMMERCIAL BRINE TANK	CQE-CO-03376	D 30" x H 50"	
---	---	---	<p>THE INFORMATION CONTAINED IN THIS DRAWING IS THE SOLE PROPERTY OF CRYSTAL QUEST. ANY REPRODUCTION IN PART OR AS A WHOLE WITHOUT THE WRITTEN PERMISSION OF CRYSTAL QUEST IS STRICTLY PROHIBITED.</p>
---	---	---	
---	---	---	
---	---	---	

UNLESS OTHERWISE SPECIFIED: DATE: 12/13/2018 DRAWN BY: DUSTIN

TITLE: NOBIE WATKINS 15 CUBE/75 GPM HIGH FLOW WATER SOFTENER SYSTEM

DIMENSION KEY:		SIZE	DWG. NO.	REV #
L	→ LENGTH	C	1	A
W	→ WIDTH	SCALE: 1:20		WEIGHT:
H	→ HEIGHT	SHEET 1 OF 1		
D	→ DIAMETER			

