



Fire Your Imagination

Studio Duplex

Balanced Flue with Thermostatic Remote Control



IMPORTANT:
FOR EASY TO FOLLOW,
STEP BY STEP VIDEO
INSTRUCTIONS ON HOW TO
OPERATE AND MAINTAIN YOUR
GAZCO REMOTE SYSTEM GO TO
WWW.GAZCO.TV

Instructions for Use, Installation & Servicing

For use in GB & IE (Great Britain & Republic of Ireland).

IMPORTANT

THE OUTER CASING, FRONT AND GLASS PANEL BECOME EXTREMELY HOT DURING OPERATION AND WILL RESULT IN SERIOUS INJURY AND BURNS IF TOUCHED. IT IS THEREFORE RECOMMENDED THAT A FIREGUARD COMPLYING WITH BS 8423 (LATEST EDITION) IS USED IN THE PRESENCE OF YOUNG CHILDREN, THE ELDERLY OR INFIRM.

This product contains a heat resistant glass panel. This panel should be checked during Installation and at each servicing interval. If any damage is observed on the front face of the glass panel (scratches, scores, cracks or other surface defects), the glass panel must be replaced and the appliance must not be used until a replacement is installed. Under no circumstances should the appliance be used if any damage is observed, the glass panel is removed or broken.

These Instructions must be left with the appliance for future reference and for consultation when servicing the appliance. Please make the customer aware of the correct operation of the appliance before leaving these instructions with them.

The commissioning sheet found on Page 3 of this Instruction manual must be completed by the Installer prior to leaving the premises.

Contents

Studio Duplex Balanced Flue

Covering the following models:

	Nat Gas	LPG
Log Effect	123-364	123-411

Appliance Commissioning Checklist3

User Instructions4

Installation Instructions12

Technical Specifications 12

Site Requirements 15

Installation 19

Commissioning31

Servicing Instructions.....32

Fault Finding32

How to Replace Parts34

Spare Parts List40

Service Records42

Information Requirements.....43



If you have purchased your stove or fire from an authorised stockist within our Expert Retailer Network, then automatically your product will carry a 2 year warranty as standard. The 2 year warranty can be further extended to a total warranty period of 5 years by registering your Gazco Stove or Fireplace within one month of the latter of the purchase date or installation date. Accordingly, the start date for the warranty period is the date of purchase. During the registration process, the Expert Retailer details will be required for your Extended Warranty to be activated. Any product purchased outside of our Expert Retailer Network will carry a standard 12 month, non-extendable warranty.

It is a condition of the Extended Warranty that the installation complies with the relevant Building Regulations and is carried out by a suitably trained and qualified individual (GasSafe in the UK or equivalent in other countries) with the certificate of installation and the Commissioning Report on Page 3 completed and retained by the end user.

Full terms and conditions are detailed in the Warranty Statement on the Gazco website www.gazco.com. In the event of any conflict of information the wording on the website shall prevail.

Important Note: Should any problems be experienced with your product, claims must first be submitted to the Expert Retailer where the appliance was purchased from who will offer immediate assistance or contact Gazco on your behalf.



It is a requirement of the Building Regulations 2010 that the installation of this appliance is notified to the Local Authority. It is the responsibility of the GasSafe registered installer to carry out this notification to the Local Authority via the GasSafe register Competent Persons Scheme in England and Wales (different rules apply in Scotland and Northern Ireland).

When the installation has been notified, GasSafe will send a Building Regulations Compliance Certificate to you containing details of the work completed. Please ensure that the person responsible for the installation of this appliance completes this notification and records it in the Appliance Commissioning Checklist on page 3.

IT IS YOUR RESPONSIBILITY TO COMPLY WITH THE BUILDING REGULATIONS AND BE ABLE TO PRODUCE THIS CERTIFICATE SHOULD IT BE REQUIRED IN THE FUTURE.

Appliance Commissioning Checklist

To assist us in any guarantee claim please complete the following information:-

IMPORTANT NOTICE

Explain the operation of the appliance to the end user, hand the completed instructions to them for safe keeping, as the information will be required when making any guaranteed claims.

FLUE CHECK	PASS	FAIL
1. Flue Is correct for appliance		
2. Flue flow Test N/A		
3. Spillage Test N/A		
GAS CHECK	PASS	FAIL
1. Gas soundness & let by test		
2. Standing gas pressure	mb	
3. Appliance working pressure (on High Setting) Minimum Pressure Requirement: NG - 17.5mbar LPG - 34.5mbar NB All other gas appliances must be operating on full	mb	
4. Gas rate	m ³ /h	
5. Does Ventilation meet appliance requirements N/A		
SAFETY CHECK		
1. Check soundness of the Thermocouple connections - including tightness and lead integrity		
2. Glass checked to ensure no damage, scratches, scores or cracks		
BUILDING CONTROL NOTIFICATION	YES	NO
1. Installer notified GasSafe/Local Authority of installation via Competent Persons Scheme?		

RETAILER AND INSTALLER INFORMATION

Retailer	Installation Company
.....
.....
Contact No.	Engineer
.....
Date of Purchase	Contact No.
.....
Model No.	GasSafe Reg No.
.....
Serial No.	Date of Installation
.....
Gas Type	

User Instructions

Welcome

Congratulations on purchasing your Studio Duplex fire, if installed correctly Gazco hope it will give you many years of warmth and pleasure for which it was designed.

The purpose of this manual is to familiarise you with your appliance, and give guidelines for its installation, operation and maintenance. If, after reading, you need further information, please do not hesitate to contact your Gazco retailer.

WARNING



In the event of a gas escape or if you can smell gas, please take the following steps:

- **Immediately turn off the gas supply at the meter/emergency control valve**
- **Extinguish all sources of ignition**
- **Do not smoke**
- **Do not operate any electrical light or power switches (On or Off)**
- **Ventilate the building(s) by opening doors and windows**
- **Ensure access to the premises can be made**

Please report the incident immediately to the National Gas Emergency Service Call Centre on 0800 111 999 (England, Scotland and Wales) , 0800 002 001 (N. Ireland) or in the case of LPG, the gas supplier whose details can be found on the bulk storage vessel or cylinder.

The gas supply must not be used until remedial action has been taken to correct the defect and the installation has been recommissioned by a competent person.

1. General

- 1.1 Installation and servicing must only be carried out by a competent person whose name appears on the GasSafe register. To ensure the engineer is registered with GasSafe they should possess an ID Card carrying the following logo:



- 1.2 In all correspondence, please quote the appliance type and serial number, which can be found on the data badge located on a plate under the Main Burner.
- 1.3 **Do not** place curtains above the appliance: You must have 300mm clearance between the appliance and any curtains at either side.
- 1.4 No furnishings or other objects should be placed within 1 metre of the front of the appliance.
- 1.5 If a shelf is fitted, a distance of 400mm above the appliance is required.
- 1.6 If any cracks appear in the glass panels do not use the appliance until the panels have been replaced.
- 1.7 Do not obstruct the flue terminal in any way, i.e. by planting flowers, trees, shrubs etc. in the near vicinity, or by leaning objects against the terminal guard.
- 1.8 Do not put any objects on the terminal guard; it will lose its shape.
- 1.9 If you use a garden sprinkler, do not let quantities of water into the flue terminal.
- 1.10 This product is guaranteed for 5 years from the date of installation, as set out in the terms and conditions of sale between Gazco and your local Gazco retailer. Please consult with your local Gazco retailer if you have any questions. In all correspondence always quote the Model Number and Serial Number.



IMPORTANT: NEVER position a television or screen above this appliance.

User Instructions

2. Operating the Appliance

The appliance is operated by thermostatic remote control.

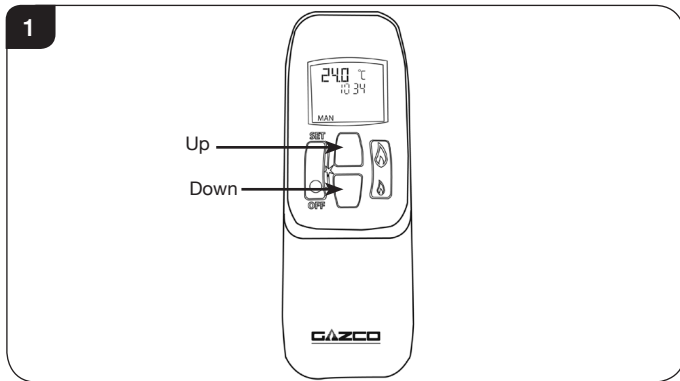

2.1 Turning the appliance On

Your remote can control the gas fire from pilot ignition through to shut down.

To turn the fire on press the OFF button and the UP button simultaneously. You hear several short signals.

The pilot and main burner ignite and the remote is now in Manual Mode.

i **IMPORTANT: YELLOW FLAMES TYPICALLY APPEAR WHEN THE APPLIANCE HAS REACHED NORMAL OPERATING TEMPERATURE. THIS CAN TAKE UP TO 30 MINUTES.**

! WARNING: IF THE APPLIANCE FAILS TO LIGHT OR BECOMES EXTINGUISHED IN USE, WAIT 3 MINUTES BEFORE ATTEMPTING TO RELIGHT.

2.2 There are 3 different modes available for controlling and operating the appliance:

1. Manual Mode
2. Temp Mode (Automatic)
3. Timer Mode (Automatic)

2.3 In **MANUAL MODE** you can:

- turn on the main burner using the UP button
- regulate the flame from high to low and back
- turn off the burner leaving just the pilot burning

In **TEMP MODE (Automatic)** you can:

- set the room temperature so the thermostat in the remote automatically maintains that temperature

In **TIMER MODE (Automatic)** the fire:

- turns on and off according to the set time periods
- automatically regulates the room temperature during the set periods

i **NOTE: When operating the fire in Temp or Timer mode, the pilot remains lit and the fire then automatically switches on at programmed times to bring the room to the set temperature whether or not you are in the room. NEVER LEAVE ANY COMBUSTIBLE MATERIALS WITHIN 1 METRE OF THE FRONT OF THE APPLIANCE.**

Switching Between Modes

- 2.4 Press the SET button to change to Temperature Mode. Press again to change to Timer Mode. Keep pressing to run through all operating modes. These are:
- MAN
 - DAY TEMP
 - NIGHT TEMP
 - TIMER
- and back to MAN
- NOTE: MAN mode can also be reached by pressing either the UP or DOWN button.**

Manual Mode

- 2.5 Press the OFF button and the UP button simultaneously. You hear several clicks and audible beeps as the fire begins the ignition process, (up to 30 seconds).

Turning the appliance Off:

Press the OFF button to turn the appliance off.

FOR SAFETY, YOU MUST WAIT 30 SECONDS BEFORE LIGHTING THE FIRE AGAIN.

Increasing the Flame Height:

Press the UP button once to increase flame height one stage. Press and hold the UP button to increase to maximum.

Decreasing the Flame Height:

Press the DOWN button once to decrease flame height one stage. Press and hold the DOWN button to decrease to minimum. At the lowest point the fire goes to 'Standby Mode' (Only Pilot lit).

i **NOTE: While pressing a button a symbol indicating transmission appears on the display. The receiver confirms transmission with a sound signal.**

Temp Mode (Automatic)

- 2.6 The display shows the current **room** temperature.

To increase or decrease the fire's output:

Press the SET button to select either the DAY TEMP or the NIGHT TEMP mode by briefly pressing the SET button.

Hold the SET button until the TEMP display flashes and then let go.

Set the desired temperature with the UP and DOWN arrows. (Minimum temperature 5C, maximum 40C or 40F to 99F when Fahrenheit is the preferred option).

Press the OFF button to stop the display flashing or wait to return to TEMP mode.

User Instructions

i **NOTE: If you set a temperature that is beneath the current room temperature, the fire automatically switches to PILOT (Stand by).**

If you would like the **Night** temperature control to turn off then decrease the temperature until [--] is displayed.

Timer Mode (Automatic)

2.7 There are two programmable settings you can make over a 24 hour period, P1 and P2. These are normally used to provide an early morning and evening setting for each working week:

- P1 + ● = Start Timed Setting 1
- P1 + ☾ = End of Timed Setting 1
- P2 + ● = Start Timed Setting 2
- P2 + ☾ = End of Timed Setting 2

2.8 P1 - Program 1 for a Timed Setting

Press the SET button until the TIMER mode is displayed.

Hold the SET button. The displays flashes the current time for P1. **While the time displayed is flashing you can alter the hours and minutes set.**

To set the time your fire first lights, change P1 ● .

- Press the UP button to alter the hour.
- Press the DOWN button to alter the minutes in 10 minute increments.

Press SET again to move to the end setting for P1 ☾ .

This is the time your Studio first shuts down:

- Press the UP button to alter the hour.
- Press the DOWN button to alter the minutes.

2.9 P2 - Program 2 for a Timed Setting

Use the same steps outlined in 2.8 to change the setting for P2.

If you have already set P1 and want to alter the setting for P2 only:

- Press the SET button until TIMER mode is displayed.
- Hold the SET button **until the display flashes the current time** for P1 ● .
- Press the SET button once again to scroll past the settings for P1 ● and P1.

With the time still flashing:

- Press the UP button to alter the hour.
- Press the DOWN button to alter the minutes.

Once all four times are set press the OFF button.

2.10 To view existing settings:

- Select Timer Mode.
- Press and briefly hold the SET button you see the start time for P1.
- Repeat the above step for the start and end of each program.

Low Battery

“BATT” is displayed on the remote when its batteries need replacement.

Setting the time

Simultaneously press the up and down buttons.

Press the up button to set the hour and the down button to set the minutes.

Press OFF to return to the manual mode or simply wait.

Setting the °C/24 Hour or °F/12 Hour clock

Press OFF and the down arrow until the display changes from °C/24 hour clock to °F/12 hour clock and vice versa.

i **If the remote is removed, lost or damaged, signals transmitted to the receiver cease. Your fire will go to standby (pilot) mode after 6 hours.**

Troubleshooting

! **IMPORTANT: In the unlikely event that the handset fails to communicate correctly with the appliance it may be necessary to turn off the gas supply at the isolation valve until any problems can be resolved.**

The gas meter and isolation valve can be located outside in a meter box, under the stairs, beneath the kitchen sink or in the garage. Whilst this list is not exhaustive, it is important to be able to identify the location of the valve in case of any gas emergency.

To turn off the gas supply, simply turn the handle so the lever is at 90 degrees to the upright gas pipe.

If you smell gas, open doors and windows and never operate any electrical switches. Immediately call the Gas Emergency Services on 0800 111 999.

User Instructions

3. Changing the Appliance Batteries

The appliance batteries are located behind the wall plate.

- 3.1 Undo the two screws securing the wall plate and remove, see Diagram 2.

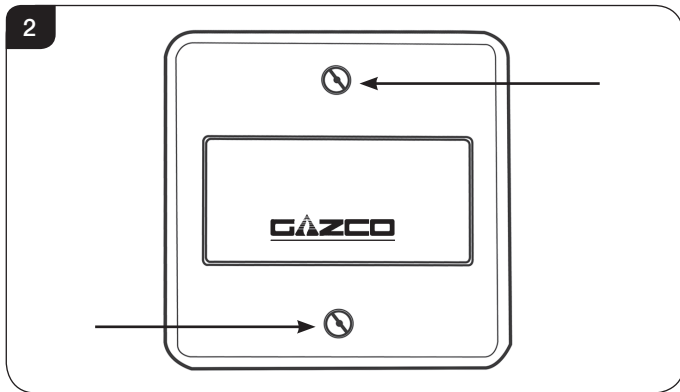

- 3.2 Unclip the battery holder from the wall plate and remove the old batteries.

i It is essential to use high quality batteries (Duracell or equivalent) when replacing batteries in the handset or control box.

- 3.3 Correctly position the four new AA size batteries into the battery holder. Re-assemble the battery holder as shown in Diagram 3.

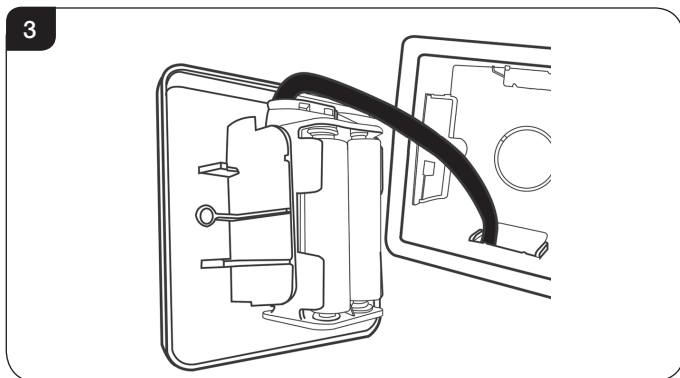

! PLEASE ENSURE NO WIRES ARE TRAPPED BEFORE REPLACING THE WALL PLATE. THE TOUCH PAD LEAD IS EASILY DAMAGED.

4. Cleaning the Appliance

- 4.1 Make sure the appliance and surrounds are cool before cleaning.
- 4.2 Use:
- A damp cloth for the painted frame.
 - A damp cloth to clean the granite/enamelled inner panels.
 - Soap and water to clean the glass.

Opening the Glass Window:

4.3 Decorative Front

If fitted with a decorative front, this needs to be removed first.

- 4.4 Lift the frame upwards off its four support brackets, see Diagram 4.

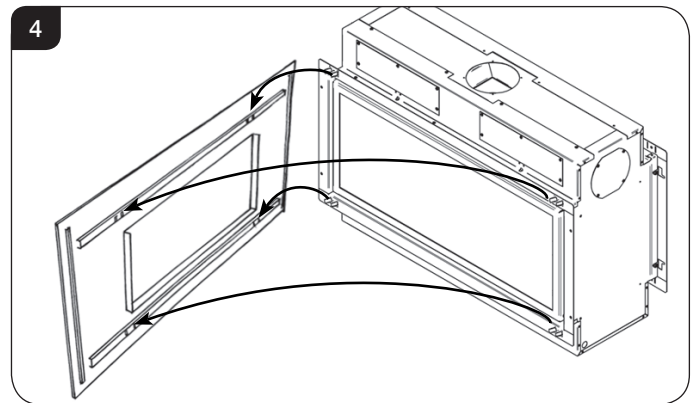

All models

- 4.5 To open the glass door use the hexagon key provided.
- 4.6 Release the window locks by moving them from shut to open towards the outer edges, see Diagram 3.

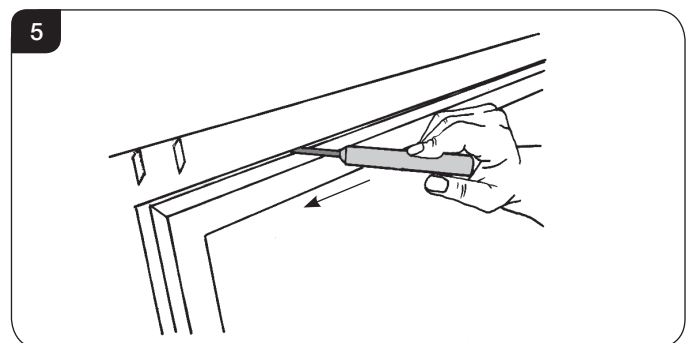

User Instructions

- 4.7 To completely remove the glass front:
- 4.8 Support the frame and lower it gently forward down to its natural stop position, see Diagram 6.
DO NOT EXERT PRESSURE ON THE DOOR ONCE THERE IS RESISTANCE.

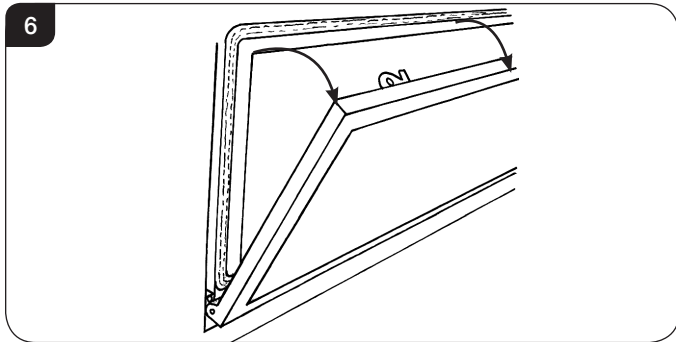

- 4.9 Remove the securing spring clip from the bottom-right of the window frame, see Diagram 7.

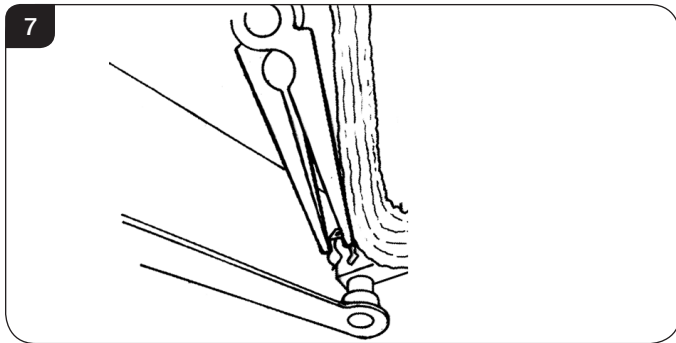

- 4.10 With the window frame in an upright position slide the frame to the left so that it comes off the left hinge pin, see Diagram 8 (1).
- 4.11 Still keeping the frame upright drop the left side down and forward slightly, see Diagram 8 (2).

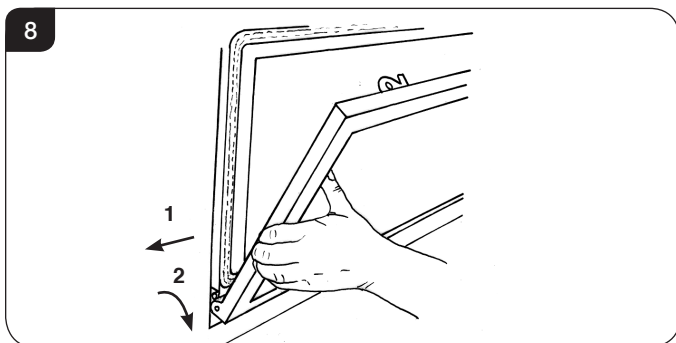

- 4.12 Slide the frame to the right so it comes off the right hinge pin. The window frame should now be free.
- 4.13 Refit the Window Frame Assembly in reverse order.

When closing the door ensure the door catches are fully engaged.

! UNDER NO CIRCUMSTANCES SHOULD THE APPLIANCE BE USED WITHOUT THE CATCHES HOLDING THE DOOR IN PLACE.

5. Arrangement of the fuel bed

Advice on handling and disposal of fire ceramics



The black reeded liners are made from Refractory Ceramic Fibre (RCF), a material which is commonly used for this application.

Protective clothing is not required when handling these articles, but we recommend you follow normal hygiene rules of not smoking, eating or drinking in the work area and always wash your hands before eating or drinking.

To ensure that the release of RCF fibres are kept to a minimum, during installation and servicing a HEPA filtered vacuum is recommended to remove any dust accumulated in and around the appliance before and after working on it. When servicing the appliance it is recommended that the replaced items are not broken up, but are sealed within heavy duty polythene bags and labelled as RCF waste.

RCF waste is classed as stable, non-reactive hazardous waste and may be disposed of at a licensed landfill site.

Excessive exposure to these materials may cause temporary irritation to eyes, skin and respiratory tract; wash hands thoroughly after handling the material.

- 5.1 **Vermiculite for Log Layout:** Use the entire bag of supplied Vermiculite.

TAKE CARE NOT TO SPILL VERMICULITE INTO THE PILOT AREA. ONLY USE THE FUEL EFFECT SUPPLIED BY GAZCO IN THIS APPLIANCE.

User Instructions

6. Log Layout

LOGS MUST BE POSITIONED ACCORDING TO THE FOLLOWING INSTRUCTIONS TO GIVE THE CORRECT FLAME EFFECT.

- 6.1 In order to install the correct log layout the pilot burner must be situated on the bottom right hand side of the appliance, see Diagram 9.

All logs can be identified by a letter (A - I) on their underside. The first 2 logs, A and B, also have holes to locate each onto a burner stud.

- 6.2 Working from left to right place logs A and B onto their studs on the burner tray, see Diagram 9.

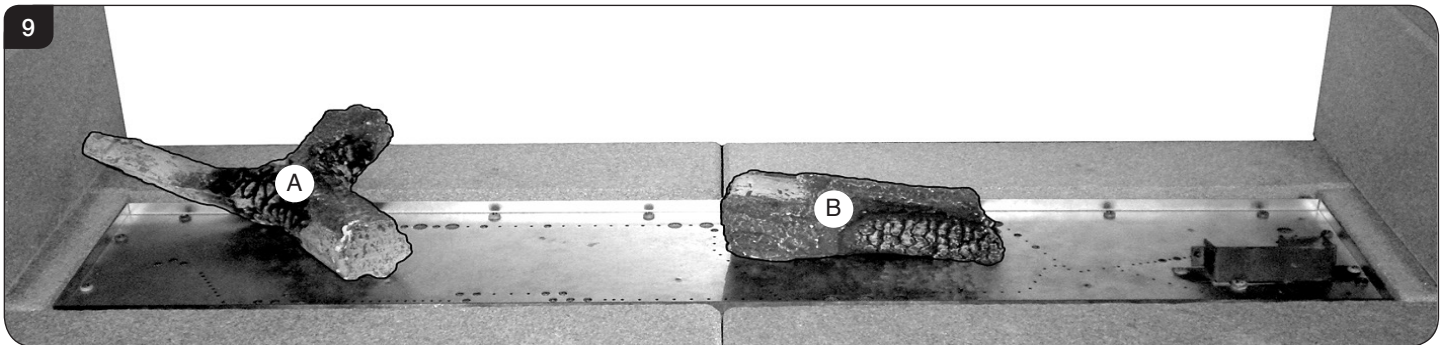

- 6.3 Use all the vermiculite to fill the burner tray between Logs A and B. Spread evenly across between the logs, so the whole burner is covered, see Diagram 10.

Ensure not to drop vermiculite down the edges of the burner tray.

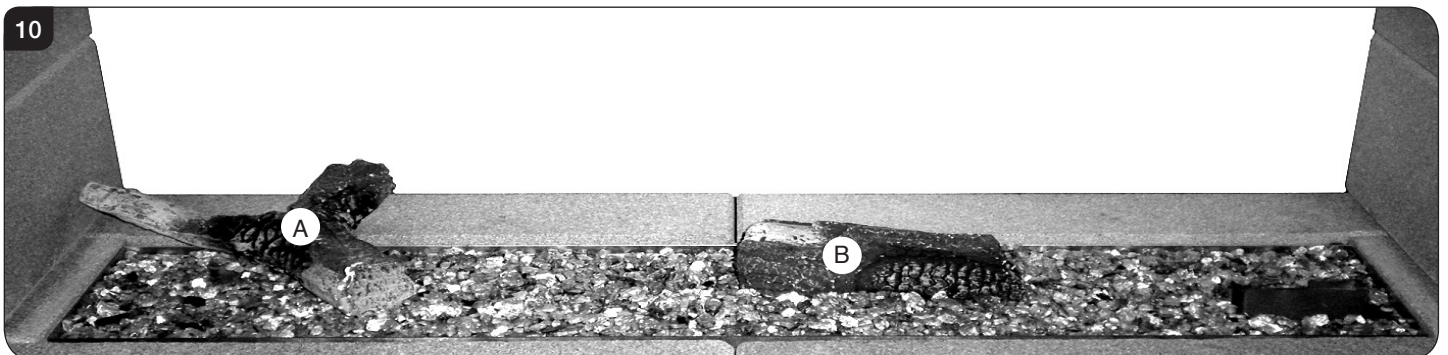
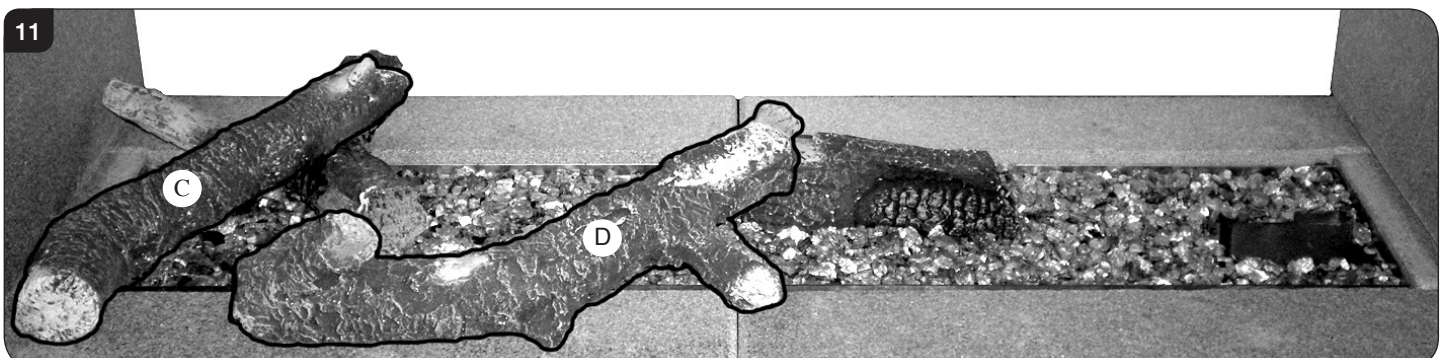

Diagram 11 shows the layout of logs C and D.

- 6.4 Place the front end of Log C on the front left panel and rest the rear end across Log A.
- 6.5 Place the front end of Log D along the front panel with the bend curving backwards with the rear end resting on Log B.



User Instructions

Diagram 12 shows the layout of logs E and F.

- 6.6 Place the back end of Log E on the back panel and rest the front end across Log D.
- 6.7 Place the front end of Log F onto the front right panel and rest the back end across Log B.

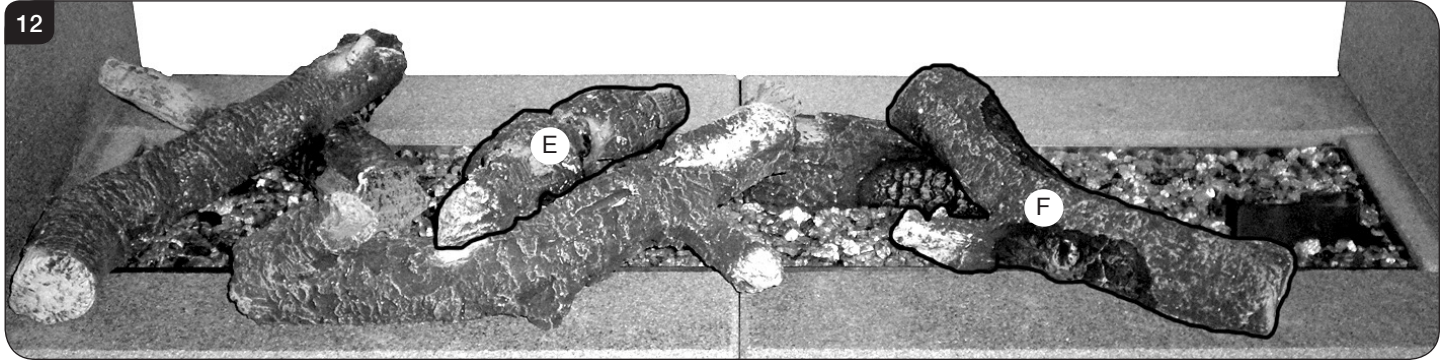

Diagram 13 shows the layout of log G.

- 6.8 Place the back end of Log G on the back right hand panel and rest the front end onto Log F.

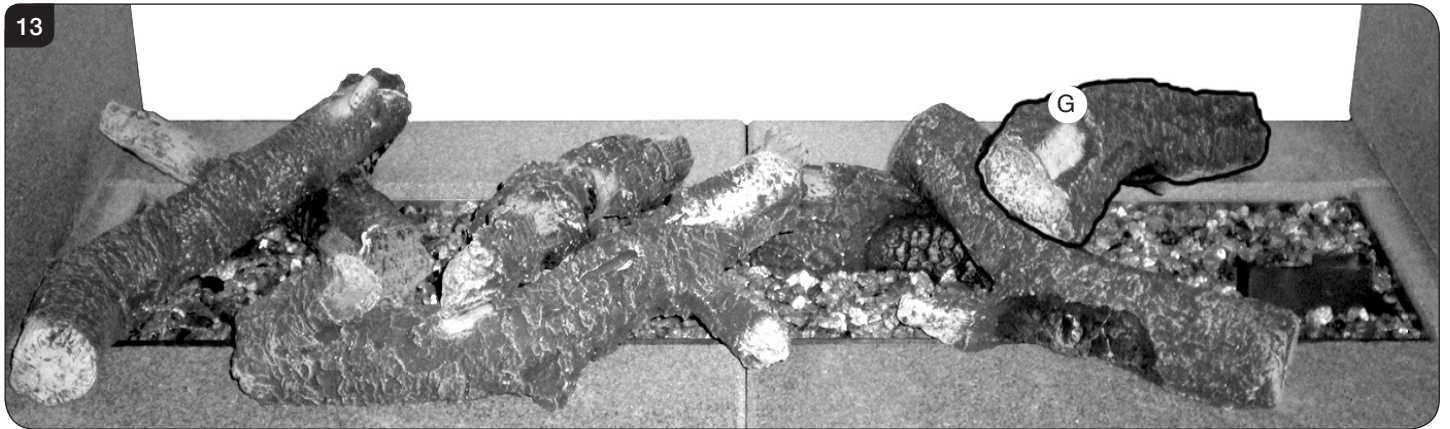
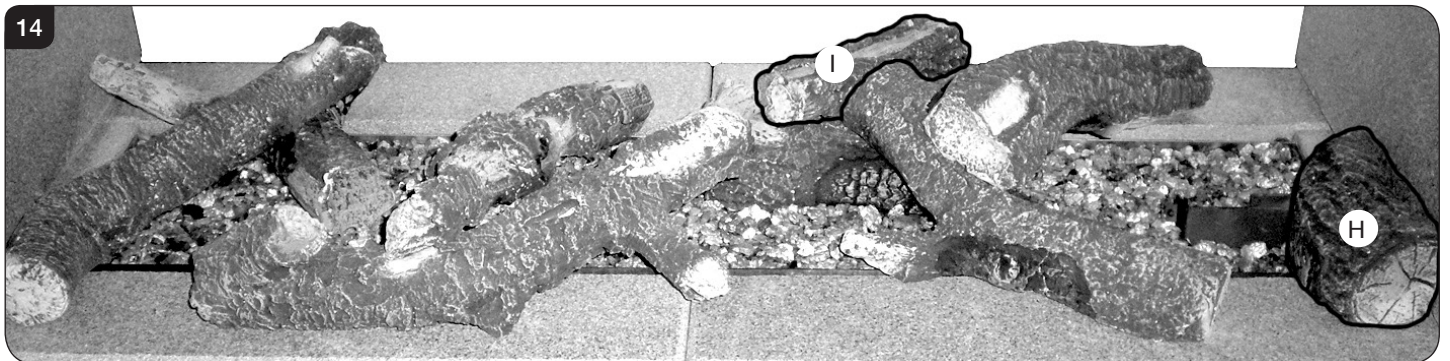

Diagram 14 shows the layout of logs H and I.

- 6.9 Place the front end of Log H onto the front right panel and against the right side panel.
- 6.10 Place the back end of Log I on the back right hand panel and rest the front end onto Log B.



User Instructions

- 6.11 Separate the Embaglow material into smaller pieces and pull into shape to create a fine layer.
- 6.12 Sprayingly spread an amount of the Embaglow fibres provided, covering the ports in the burner tray, see Diagram 15.
Ensure the material is placed loosely to create a random glow.
Take care not to use more than half a packet per application.
WARNING - DO NOT PLACE NEAR THE PILOT AREA.

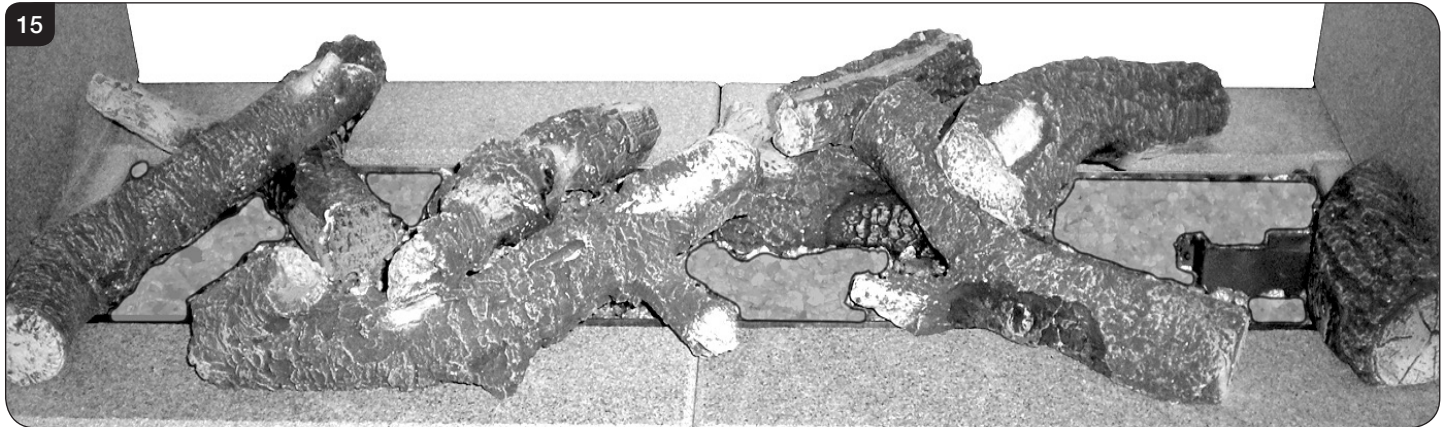

7. Flame Failure Device

- 7.1 This is a safety feature incorporated on this appliance which automatically switches off the gas supply if the pilot goes out and fails to heat the thermocouple.

IF THIS OCCURS DO NOT ATTEMPT TO RELIGHT THE APPLIANCE FOR 3 MINUTES.

8. Running In

- 8.1 During initial use of a new GAZCO appliance a strong odour will be encountered as various surface coatings become hot for the first time. Although these odours are harmless it is recommended that the appliance is operated on maximum for 4 to 8 hours in order to fully burn off these coatings. After this period the odours should then disappear.
- If the odours persists, please contact your installer for advice.
- 8.2 During the first few hours of burning there may be discolouration of the flames. This will also disappear after a short period of use.

9. Servicing

- 9.1 The appliance must be serviced every 12 months by a qualified GasSafe Engineer. In all correspondence always quote the Model number and the Serial number which may be found on the Commissioning Checklist (Page 3).

10. Ventilation

- 10.1 This appliance requires no additional ventilation.

11. Installation Details

- 11.1 Your installer should have completed the commissioning sheet at the front of this book. This records the essential installation details of the appliance. In all correspondence always quote the Model number and Serial number.

12. Hot Surfaces

- 12.1 Parts of this appliance become hot during normal use.
- 12.2 Regard all parts of the appliance as a working surface.
- 12.3 Provide a suitable fire guard to protect young children and the infirm.

13. Appliance will not light

If you cannot light the appliance:

- 13.1 Check and change the batteries in the remote handset.
- 13.2 Check and change the wall plate batteries (see Section 3).
- 13.3 Consult your Gazco retailer or installer if the appliance still does not light.

Installation Instructions

Technical Specification

Covering the following models:

	Nat Gas	LPG
Log Effect	123-364	123-411

Log Versions

Model	Gas CAT.	Gas Type	Working Pressure	Aeration	Injector	Gas Rate m ³ /h	Input kW (Gross)		Country
							High	Low	
Studio 2 Duplex	I ₂ H	Natural (G20)	20mbar	14mm x 15mm	700	0.908	9.6	4.0	GB, IE
	I ₃ P	Propane (G31)	37mbar	14mm x 15mm	161	0.361	9.3	4.5	GB, IE
				16mm x 23mm					
Efficiency Class 1 - 92% / NO_x Class 4									
Flue Outlet Size Ø 100mm									
Flue Inlet Size Ø 150mm									
Gas Inlet Connection Size Ø 8mm									

i The net efficiency of this appliance has been measured as specified in EN613:2001 and the result after conversion to gross using the appropriate factor from Table E4 of SAP 2012 is 83%. The test data has been certified by Kiwa Nederland BV. The gross efficiency value may be used in the UK Government's Standard Assessment Procedure (SAP) for energy rating of dwellings.

RESTRICTOR REQUIREMENT

VERTICAL & HORIZONTAL FLUE			TOP EXIT - VERTICAL ONLY INCLUDING OFFSET	
Vertical Flue Height	Horizontal Length	Restrictor Size	Vertical Flue Height	Restrictor Size
Nat Gas			Nat Gas	
1000mm - 1499mm	Up to 1000mm	No restrictor	3000 - 5999mm	Ø 70mm
1500mm - 1999mm	Up to 3000mm	No restrictor	6000mm - 10,000mm	Ø 60mm
2000mm - 3000mm	Up to 5000mm	No restrictor		
LPG			LPG	
1000mm - 1499mm	Up to 1000mm	No restrictor	3000 - 5999mm	Ø 60mm
1500mm - 1999mm	Up to 3000mm	No restrictor	6000mm - 10,000mm	Ø 52mm
2000mm - 2499mm	Up to 4000mm	No restrictor		
2500mm - 3000mm	Up to 5000mm	No restrictor		

Installation Instructions

Technical Specification

This appliance has been certified for use in countries other than those stated. To install this appliance in these countries, it is essential to obtain the translated instructions and in some cases the appliance will require modification. Contact Gazco for further information.

PACKING CHECKLIST

Qty	Description	Fixing Kit containing:
	Log Version:	1 x Instruction Manual
1	x Log Set	1 x Quick Star Guide
1	x Vermiculite	12 x Wood Screws
1	x Bag Embaglow material	12 x Wall Plugs
		2 x Countersunk Screws
		1 x Handset
		4 x AA cell batteries
		1 x 9v cell batteries
		1 x Wall box
		1 x Wall plate
		1 x Battery holder
		2 x Foam seal
		Door Tool

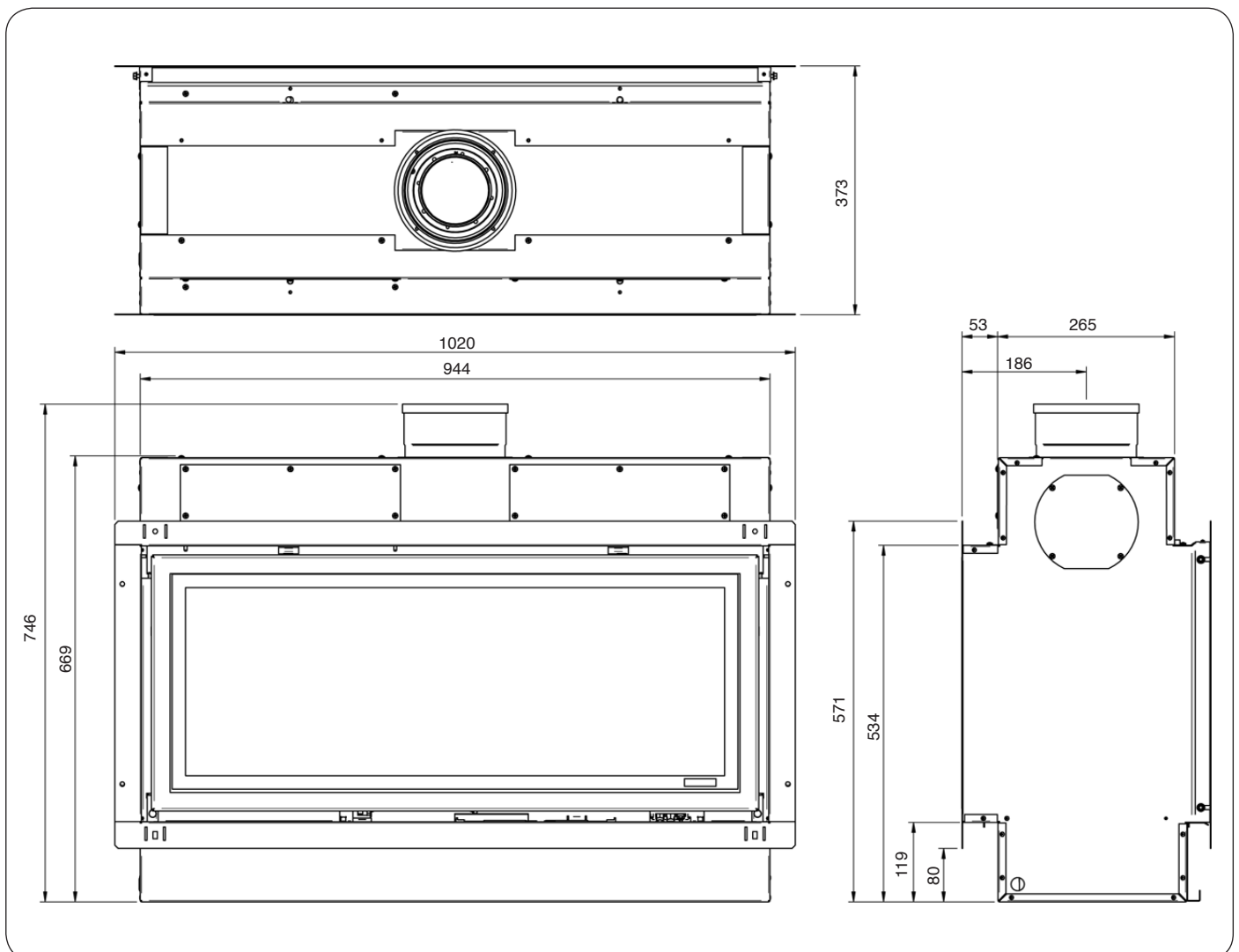

Installation Instructions

Technical Specification

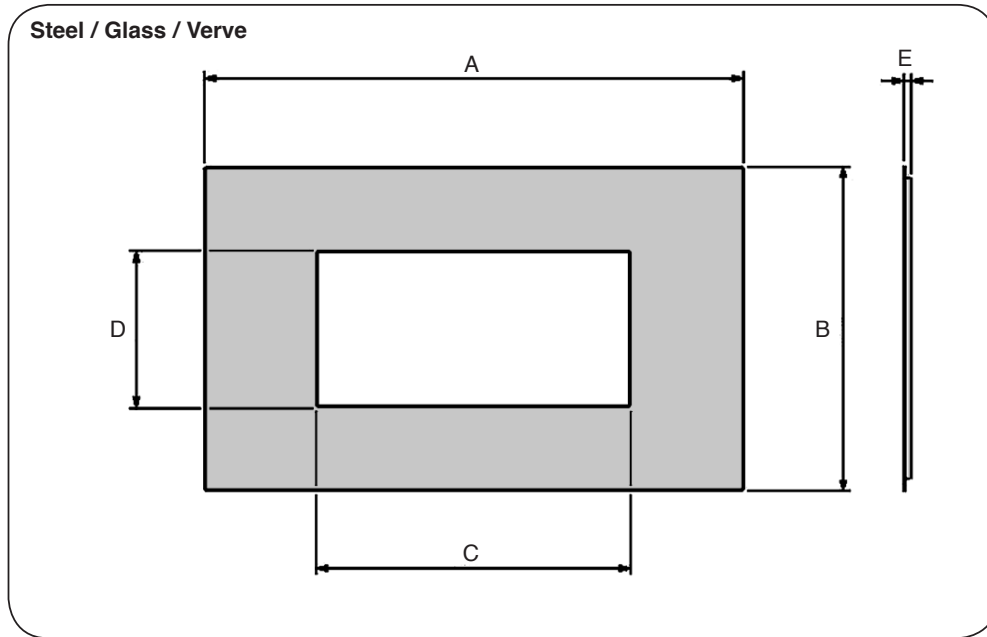

Steel / Glass / Verve Fronts					
Front	A	B	C	D	E
Steel	1500	528	846	320	27
Glass	1500	528	852	324	29
Verve	1500	528	850	324	53

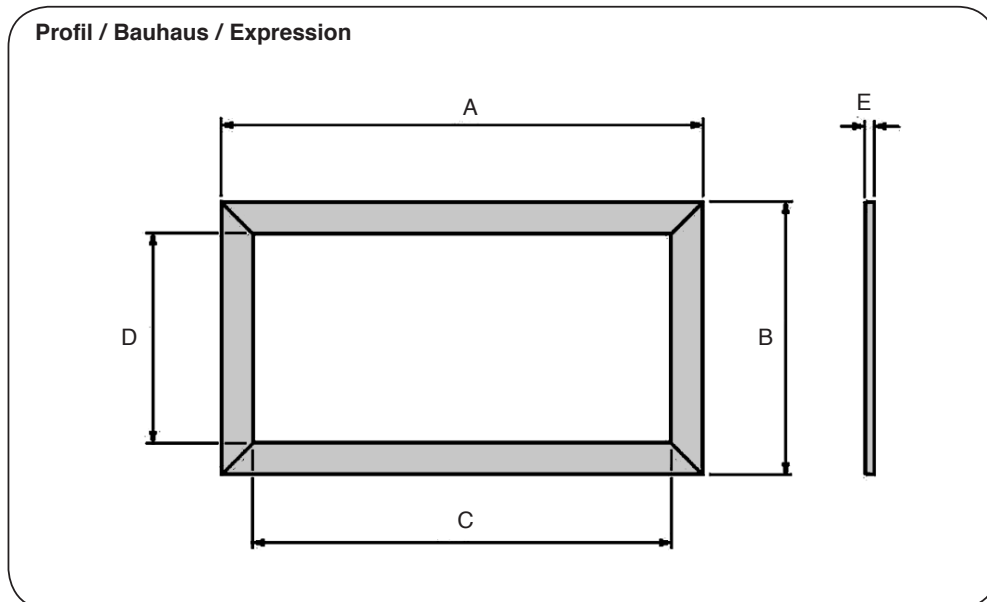

Profil / Bauhaus / Expression Frames					
Frame	A	B	C	D	E
Profil	1036	510	940	414	12.5
Bauhaus	1050	524	940	414	28
Expression	1140	614	940	414	40

Installation Instructions

Site Requirements

1. Flue & Chimney Requirements

Note: This appliance must only be installed with the flue supplied.

You must adhere to the following:

- 1.1 The flue must be sited in accordance with BS5440: Part 1 (latest edition), see Diagram 1.
- 1.2 Fit a guard to protect people from any terminal less than 2 metres above any access such as level ground, a balcony or above a flat roof.
- 1.3 All vertical and horizontal flues must be securely fixed and fire precautions followed in accordance with local and national codes of practice.
- 1.4 A restrictor may be required, see Technical Specifications on page 12.

- 1.5 Two types of flue terminals are available, horizontal and vertical.
- 1.6 To measure for a horizontal terminal decide on the terminal position.
- 1.7 Measure the height from the top of the appliance to the centre of the required outlet.
- 1.8 For minimum and maximum flue dimensions see Diagrams 2A/2B.
- 1.9 Allow enough room either above or to the side of the appliance to assemble the flue on top.
- 1.10 Assemble a horizontal flue in the following order:
 - Vertical section
 - 90° elbow
 - Horizontal plus terminal
- 1.11 Support the opening of a masonry installation with a lintel.
- 1.12 Only the horizontal terminal section can be reduced in size.

1 UK Dimensions

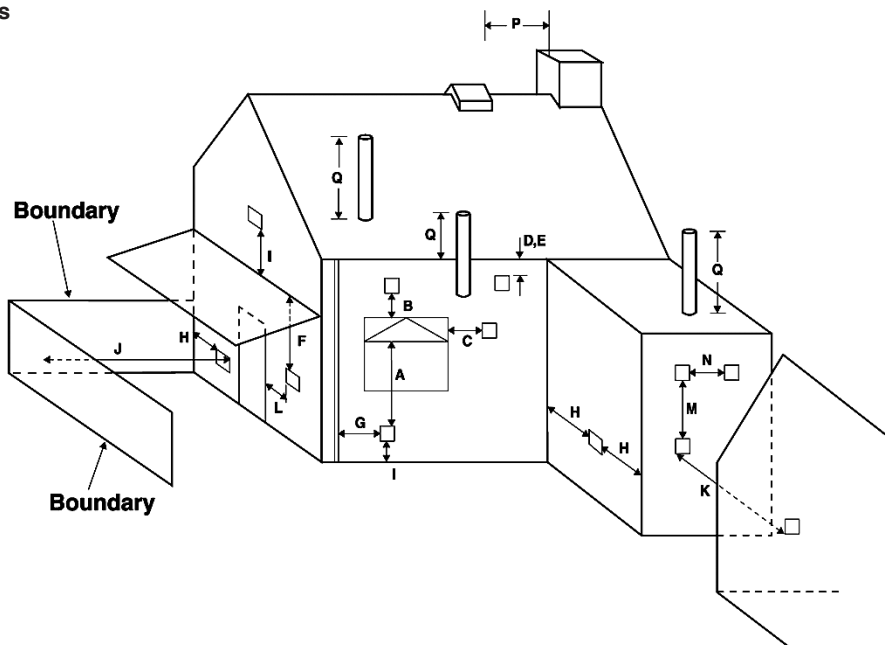

Dimension	Terminal Position	Minimum Distance
A*	Directly below an opening	600mm
B*	Above an opening	300mm
C*	Horizontally next to an opening	400mm
D	Below gutters, soil pipes or drain pipe	300mm
E	Below eaves	300mm
F	Below balcony or car port roof	600mm
G	From a vertical drain pipe or soil pipe	300mm
H	From an internal or external corner or to a boundary alongside the terminal	600mm
I	Above ground, roof or balcony level	300mm

Dimension	Terminal Position	Minimum Distance
J	From a surface or boundary facing the terminal	600mm
K	From a terminal facing the terminal	600mm
L	From an opening in the car port (e.g. door, window) into the dwelling	1200mm
M	Vertically from a terminal on the same wall	1200mm
N	Horizontally from a terminal on the same wall	300mm
P	From a structure on the roof	600mm
Q	Above the highest point of intersection with the roof	300mm

* In addition, the terminal should not be nearer than 300mm to an opening in the building fabric formed for the purpose of accommodating a built-in element such as a window frame.

Installation Instructions

Site Requirements

2. Flue Options

STUDIO DUPLEX BF - Nat Gas

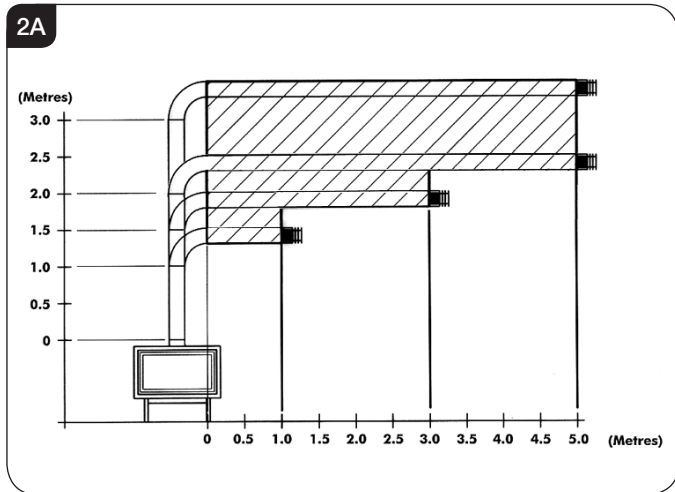

STUDIO DUPLEX BF - LPG

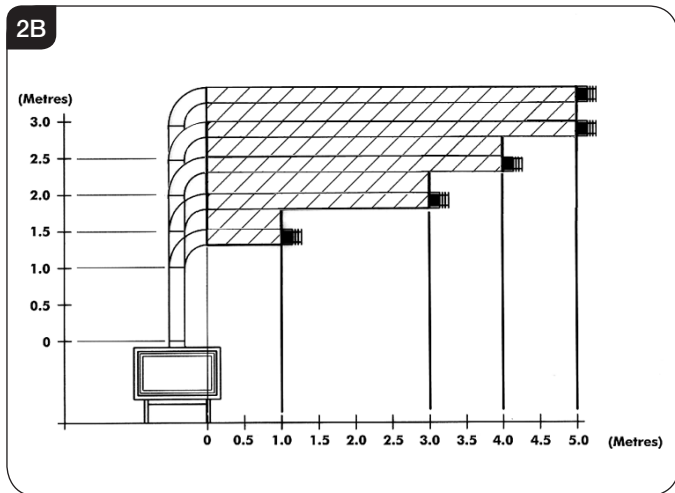

Start of bend to centre line of horizontal flue 170mm. Centre line of vertical flue to end of bend 220mm.

2B. Top Flue Up and Out with Additional Bend

2.2 Any additional bend may be used on the horizontal section (either 45° or 90°), but the overall horizontal flue run will be reduced. Refer to Diagram 2C.

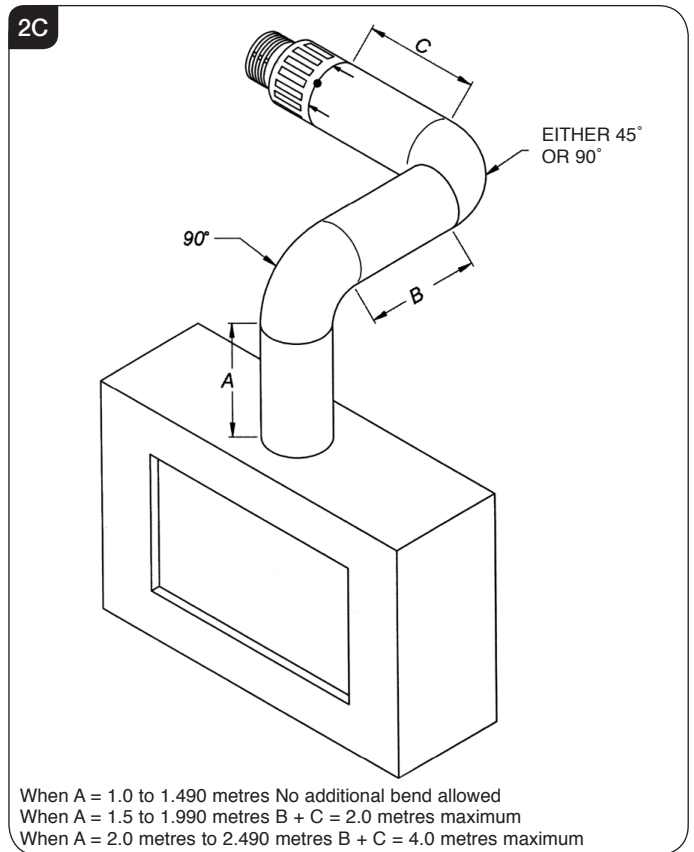

2A. Top Flue Up and Out Kit

2.1 Vertical from the top of the appliance then horizontally out, see Diagram 2A. The basic kit comprises:

STUDIO DUPLEX BF (8567/8567AN)

- 1 x 1000mm vertical length
- 1 x 500mm terminal length (cut to length on site)
- 1 x 90° elbow
- 1 x wall plate

The kit may be used on its own. Extra lengths may be added to the vertical and horizontal, see Section 3.

Installation Instructions

Site Requirements

2C. Top Flue Vertical Kit (8524/8524AN)

- 2.3 Vertical from the top of the appliance, see Diagram 2D. A minimum vertical rise 3m (9'10") to a maximum 10m (32'10"). The basic kit comprises:
- 2 x 1m lengths
 - 1 x 1m terminal length
 - 1 x 52mm restrictor
 - 1 x 47mm restrictor
 - 1 x 60mm restrictor
 - 1 x 70mm restrictor
- Extra lengths may be added from the table, see Section 3.

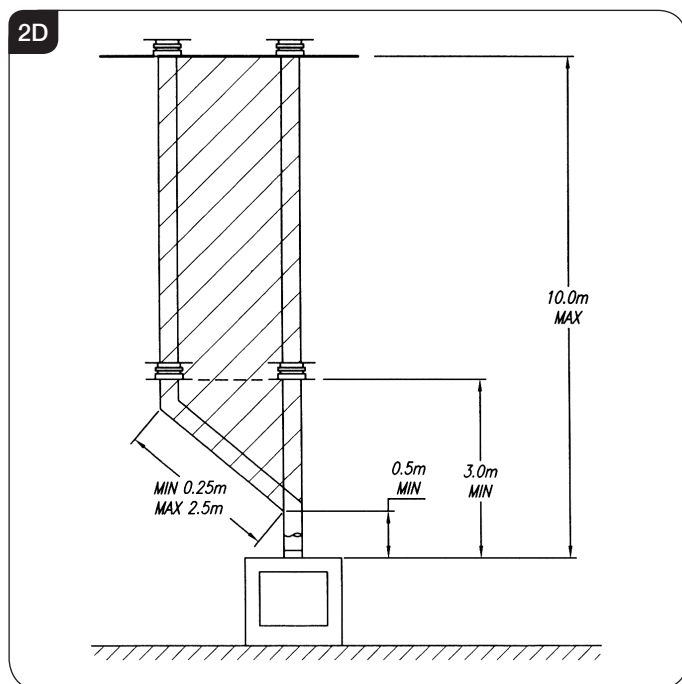

i This Gazco balanced flue system is designed to run internally with only the terminal projecting from the building.

2D. Top Flue Vertical Offset Kit (8530/8530AN)

- 2.4 Used with kit 8524. A minimum rise of 500mm (19½") is required to the first bend, see Diagram 2D.

3. Optional Extra Flue Lengths and Bends

All flue components are 150mm diameter (6").

Nominal Length	Actual Length	Stainless Finish	Anthracite Finish
200mm	140mm	8527	8527AN
500mm	440mm	8528	8528AN
1000mm	940mm	8529	8529AN
40° Bend	N/A	8507	8507AN
90° Bend	N/A	8508	8508AN

NOTE - Carefully consider:

- a) Terminal positions
- b) Flue supports
- c) Weatherproofing
- d) Fire precautions

For all the above options, you must conform to local and national codes of practice.



IMPORTANT:
1M VERTICAL, TERMINAL AND STRAIGHT FLUE LENGTHS MUST NOT BE CUT!

4. Gas Supply

This appliance is intended for use on a gas installation with a governed meter.

- 4.1 Before installation, ensure that the local distribution conditions (identification of the type of gas and pressure) and the adjustment of the appliance are compatible.
- 4.2 Ensure the gas supply delivers the required amount of gas and is in accordance with the rules in force.
- 4.3 Soft copper tubing can be used on the installation and soft soldered joints outside the appliance and below the firebed.
- 4.4 A factory fitted isolation device is part of the inlet connection; no further isolation device is required.
- 4.5 All supply gas pipes must be purged of any debris that may have entered prior to connection to the appliance.
- 4.6 The gas supply enters through the silicone panel located on the LEFT-HAND side of the outer box. Slit with a sharp knife before passing the supply pipe through.
- 4.7 The gas supply must be installed in a way that does not restrict the removal of the appliance for servicing and inspection.

Installation Instructions

Site Requirements

5. Ventilation

- 5.1 This appliance requires no additional ventilation.

6. Appliance Location

- 6.1 Please note this appliance has been designed for studwork installations. There are three decorative finishing options that can be used on both sides or in a combination with another depending on individual preference.
IMPORTANT: These finishing methods will effect the construction of the studwork so the relevant sections must be consulted before beginning the installation.

The three decorative finishing options are:

Frame (see Installation Instructions, Section 4).
Edge (see Installation Instructions, Section 5).
Cool Wall (see Installation Instructions, Section 6).

- 6.2 This appliance must stand on a non-combustible platform that is at least 12mm thick.

NOTE: If you intend to construct the fascia of the fireplace opening from natural materials it is recommended you cut this into three or more sections to prevent cracking. Resin-based materials may not be suitable. This appliance is an effective heat producer and attention must be paid to the construction and finish of the fireplace.

- 6.3 A combustible shelf must be:
- Maximum 150mm in depth.
 - Minimum 400mm high above the appliance.

A combustible side wall must be a minimum of 150mm from the appliance.

- 6.4 This appliance can be installed with an up and out flue (vertical wall - horizontal flue) or with a vertical flue with roof termination (see Site Requirements, Section 2, Flue Options).
- 6.5 This appliance is not suitable for installation onto a combustible wall. Remove all combustible material from the area shown, see Installation, Section 3.1.

Installation Instructions

1. Safety Precautions

- 1.1 For your own and other's safety, you must install this appliance according to local and national codes of practice. Failure to install the appliance correctly could lead to prosecution. **Read these instructions before installing and using this appliance.**
- 1.2 These instructions must be left intact with the user.
- 1.3 Do not attempt to burn rubbish on this appliance.
- 1.4 Keep all plastic bags away from young children.
- 1.5 Do not place any object on or near to the appliance and allow adequate clearance above the appliance.

IF THE APPLIANCE IS EXTINGUISHED OR GOES OUT IN USE, WAIT 3 MINUTES BEFORE ATTEMPTING TO RELIGHT THE APPLIANCE.



IMPORTANT: REFER TO DATA BADGE AND TECHNICAL SPECIFICATION AT THE FRONT OF THE MANUAL TO ENSURE THE APPLIANCE IS CORRECTLY ADJUSTED FOR THE GAS TYPE AND CATEGORY APPLICABLE IN THE COUNTRY OF USE.

FOR DETAILS OF CHANGING BETWEEN GAS TYPES REFER TO SERVICING, SECTION 15, REPLACING PARTS.

Unpacking

- 1.6 Remove the appliance from its packaging, and check that it is complete and undamaged.

Put the loose ceramic parts to one side so that they are not damaged during installation.

2. Installation of the Appliance

GAZCO RECOMMENDS THIS APPLIANCE IS INSTALLED INTO A STUDWORK CONSTRUCTION.

This method of installation will require the attachment of frame fixing brackets prior to the installation of the outer box see Section 4.8.



THERE IS AN OPTIONAL DUCT KIT, CODE No. 8572 WHICH CAN BE FITTED AT THE SAME TIME AS THE APPLIANCE INSTALLATION.

- 2.1 To open the glass door use the hexagon key provided.
- 2.2 Release the window locks by moving them from shut to open towards the outer edges, see Diagram 1.

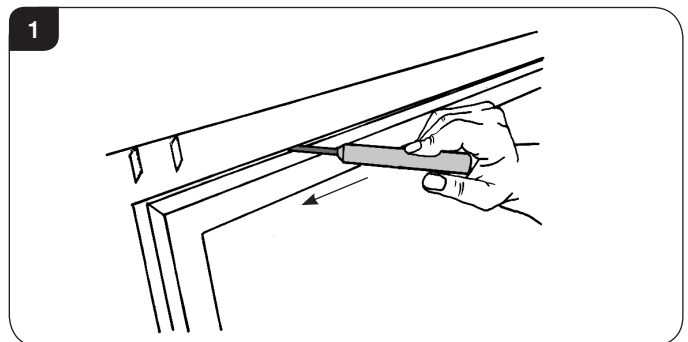

- 2.3 To completely remove the glass front:
- 2.4 Support the frame and lower it gently forward down to its natural stop position, see Diagram 2.
DO NOT EXERT PRESSURE ON THE DOOR ONCE THERE IS RESISTANCE.

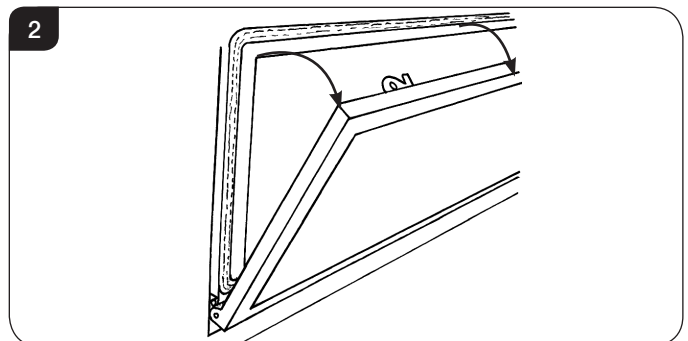

- 2.5 Remove the securing spring clip from the bottom-right of the window frame, see Diagram 3.

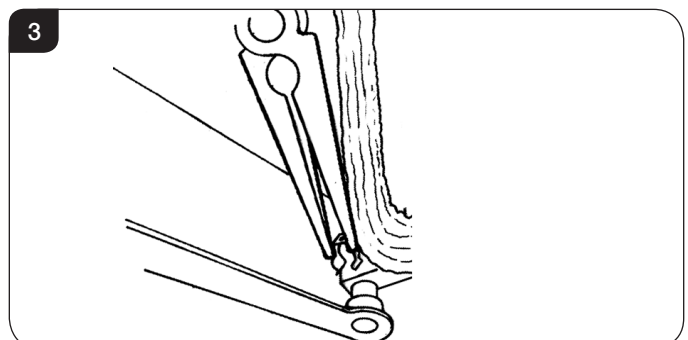

Installation Instructions

- 2.6 With the window frame in an upright position slide the frame to the left so that it comes off the left hinge pin, see Diagram 4 (1).
- 2.7 Still keeping the frame upright drop the left side down and forward slightly, see Diagram 4 (2).

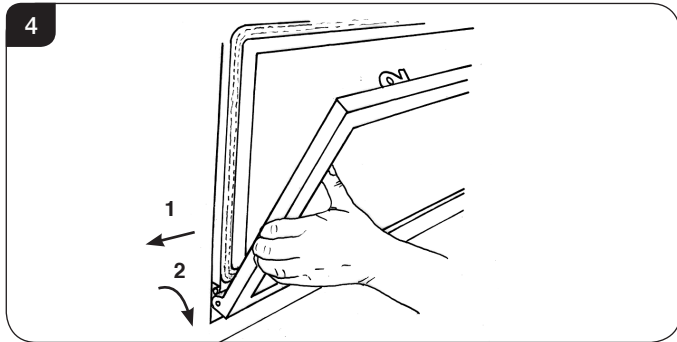

- 2.8 Slide the frame to the right so it comes off the right hinge pin. The window frame should now be free.
- 2.9 Refit the Window Frame Assembly in reverse order.

When closing the door ensure the door catches are fully engaged.

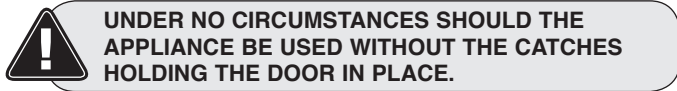

UNDER NO CIRCUMSTANCES SHOULD THE APPLIANCE BE USED WITHOUT THE CATCHES HOLDING THE DOOR IN PLACE.

- 2.10 Remove all the liners where necessary, see Replacing Parts, Section 5.
- 2.11 Remove the Main Burner, see Replacing Parts, Section 6.
- 2.12 The gas supply enters the appliance through a silicon panel on the floor under the access panel, see Diagram 5.

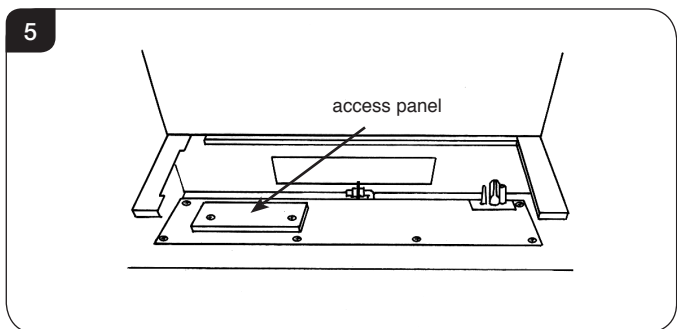

- 2.13 Slit with a sharp knife before bringing through the supply pipe, see Diagram 6.

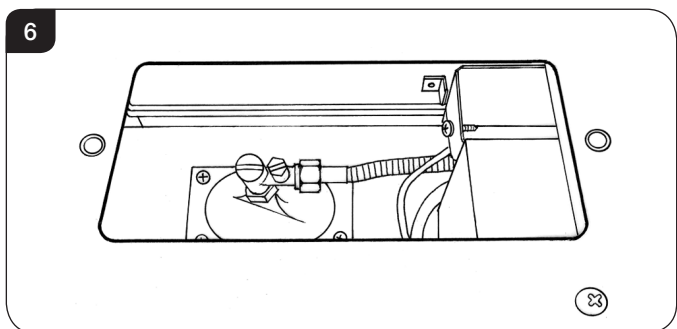

3. Studwork Installation

THERE ARE THREE TYPES OF INSTALLATION INTO STUDWORK DESCRIBED IN THE FOLLOWING PAGES:

- 1) **FOR DUPLEX WITH A DECORATIVE FRONT, SEE SECTION 4.**
- 2) **FOR AN INSTALLATION WHERE THE DUPLEX SITS FLUSH TO THE FINISHED 'EDGE' OF THE WALL, SEE SECTION 5.**
- 3) **FOR A FURTHER 'EDGE' INSTALLATION PROVIDING A COOL WALL ABOVE THE APPLIANCE TO ALLOW CUSTOMERS TO HANG PICTURES ETC, SEE SECTION 6.**

3.1 DISTANCE TO COMBUSTIBLE MATERIAL

COMBUSTIBLE PARTS OF THE STUDWORK MUST BE KEPT BEYOND THE MINIMUM DIMENSIONS SHOWN IN DIAGRAM 7. EVEN IF THE FRAMEWORK IS PROTECTED BY NON-COMBUSTIBLE MATERIAL, YOU MUST MAINTAIN THESE DIMENSIONS, SEE DIAGRAM 7.

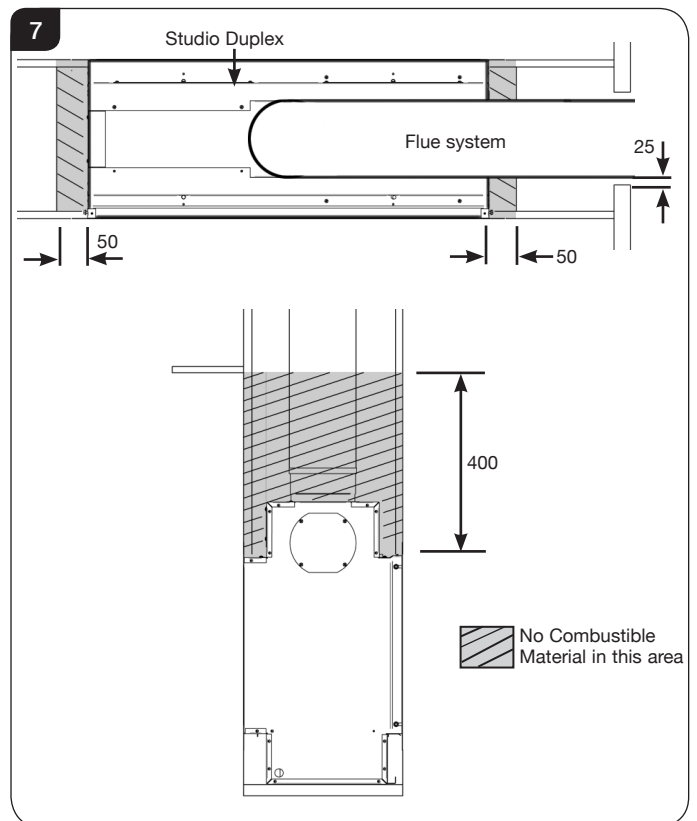

- 3.2 **DO NOT PACK THE VOID AROUND OR ABOVE THE APPLIANCE WITH INSULATION MATERIALS SUCH AS MINERAL WOOL.**

Installation Instructions

- 3.3 **THE VOID BUILT FOR THE CASSETTE MUST BE VENTILATED TO PREVENT A BUILD-UP OF HEAT. IF THE VOID IS SEALED, THEN YOU MUST FIT VENTS AT BOTH LOW AND HIGH LEVELS OF APPROXIMATELY 50CM² EACH. THESE VENTS MUST TAKE COLD AIR FROM THE ROOM AND RETURN WARM AIR BACK INTO THE ROOM.**
- 3.4 **AN ACCESS HATCH MUST BE LEFT IN THE SIDE OF THE CHIMNEY BREAST FOR FUTURE SERVICING AND INSPECTION OF THE FLUE AND APPLIANCE.**

4. Studwork Installation for Studio with frames

- 4.1 Build the studwork chimney breast and enclosures to the desired size to include the protected platform at the required height.
- 4.2 Line the aperture for the appliance with 12mm thick non-combustible material as shown, see Diagram 8.

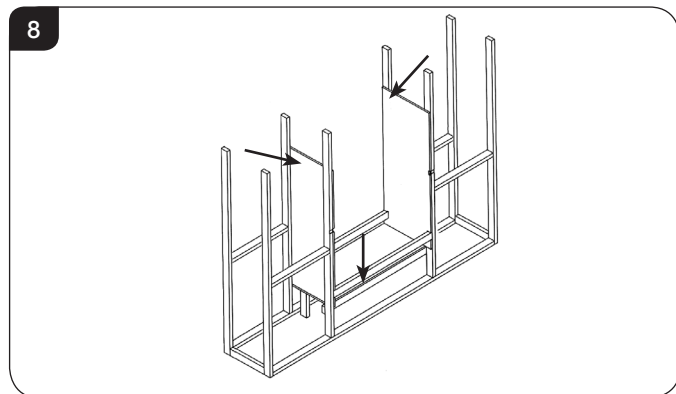

- 4.3 Ensure the clearances are maintained, see Diagram 4.
- 4.4 Site the appliance and decide on flue requirements.
- 4.5 Provide gas and electric services into the cassette void on the left-hand side.

Because no combustible material can be used above the appliance, we provide a support bar:

- 4.6 **Mark out the position to fit the supplied top support bar into the studwork at the correct height. This bar needs to be recessed into the studwork, see Diagram 9.**

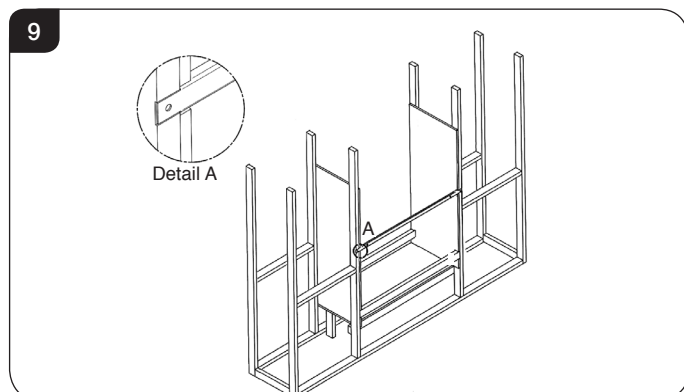

- 4.7 Fit the support bar into the studwork at the correct height, see Diagram 10.

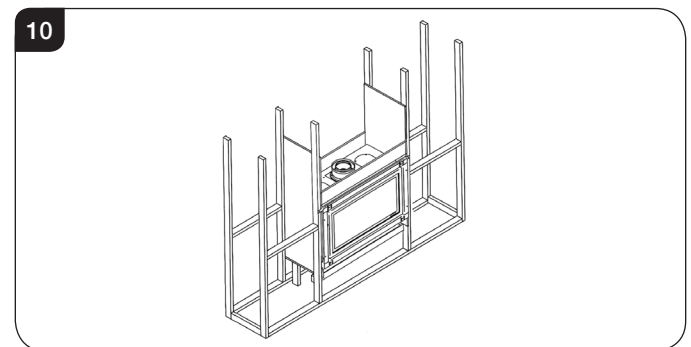

- 4.8 Attach the 4 x frame fixing brackets to the appliance, see Diagram 11.

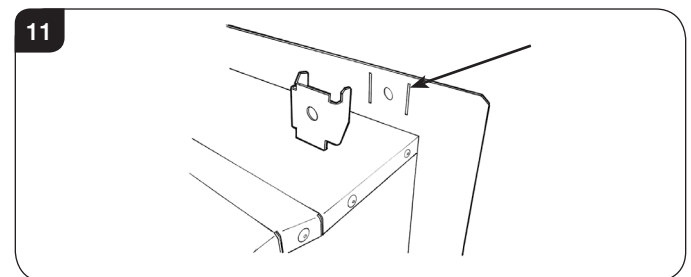

- 4.9 Fix foam seal to the rear of the outer flange of the appliance, see Diagram 12.

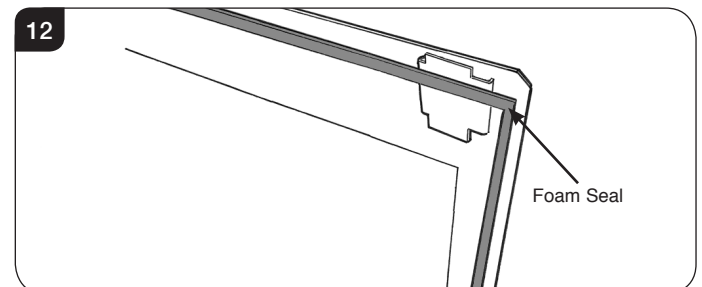

- 4.10 Position the appliance in the studwork.
- 4.11 There is an adjustable flange on one side of the appliance that allows the depth to be adjusted up to an extra 8mm to aid with the installation.
- 4.12 Fit non-combustible board to the studwork on the opposite side to the adjustable flange. This should extend a minimum of 400mm above the appliance and at least 50mm to the sides of the appliance (from the outer box, not the flanges).
- 4.13 Apply plasterboard to the remainder of the studwork.
- 4.14 Secure the back of the appliance to the studwork using four screws through flange, bracket and support bar.
- 4.15 Apply a plaster finish to the chimney breast.
- 4.16 Connect the flue system from the open side of the studwork, see Installation Section 8.
- 4.17 Apply plasterboard to the open side of the chimney breast and use the adjustable flange to ensure that there are no gaps in the installation.

Installation Instructions

Slips

Because of the high temperatures this appliance achieves, it is advisable to use marble slips or similar material between the appliance and the plasterboard.

Never use a one-piece slip as expansion (even cracking) can occur.

Note: If a slip is used, longer screws are needed to secure the appliance.

To finish this installation:

- 4.18 Connect the wall box and batteries following the instructions in Section 7 below.
 - 4.19 Connect:
 - Gas services, see Installation, Section 2, using the opening in the side of the chimney breast for access.
- After commissioning:
- 4.20 Finish the sides of the chimney breast, see Diagram 13.

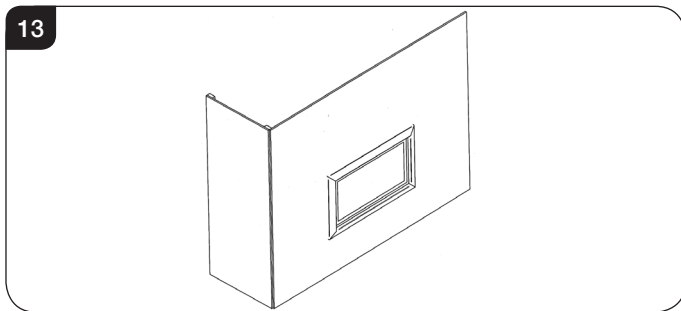

5. Studwork for Studio Edge installation kit

There is an optional Studio Edge Installation Kit available for installing the appliance without a frame.

Using the installation kit:

- 5.1 Fit the four metal brackets of the kit to the appliance, see Diagram 14.

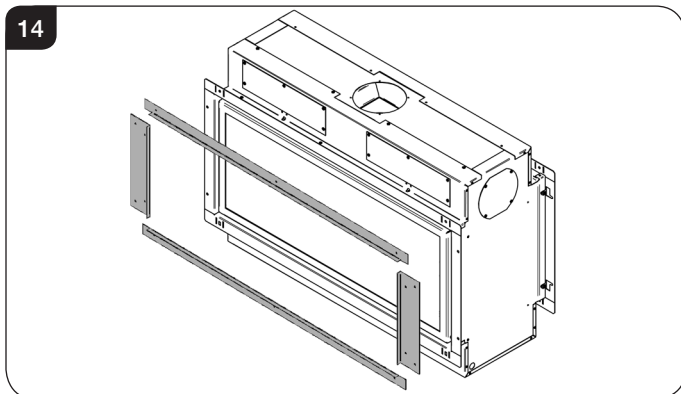

- 5.2 Fix foam seal to the rear of the outer flange of the appliance, see Diagram 15.

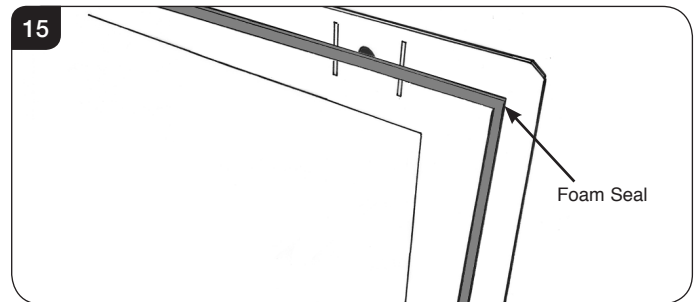

- 5.3 Put vertical studwork at minimum clearance to the side of the appliance (50mm).
- 5.4 Secure to the vertical studwork through the holes in the metal brackets fitted to the appliance.
- 5.5 The kit has been designed so that non-combustible board can be taken right up to the edge of the four brackets, see Diagrams 16 & 17.

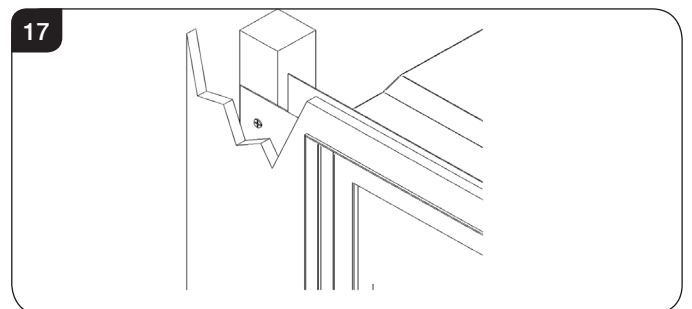
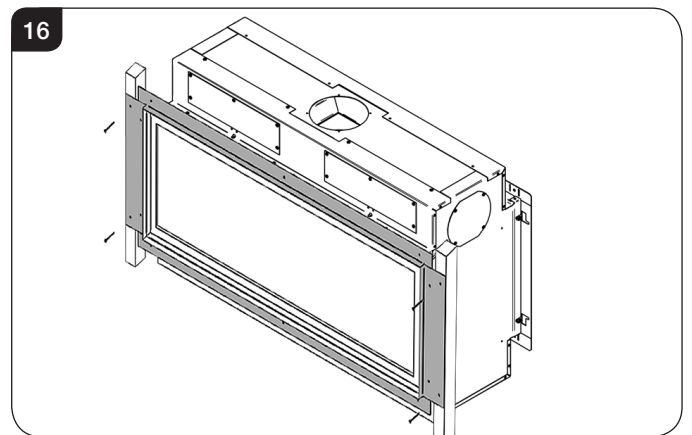

- 5.6 Build the studwork chimney breast to the desired size.
- 5.7 Ensure all clearances to combustible material are maintained (see Section 3.1 above).
- 5.8 Decide on flue requirements.
- 5.9 Fit non-combustible board to the studwork above the appliance. This should extend a minimum of 400m above the appliance.
- 5.10 Fit plasterboard to the remaining chimney breast front.

Installation Instructions

- 5.11 Connect the flue system and gas services using the opening in the side of the chimney breast for access.
- 5.12 After commissioning, finish the sides of the chimney breast, see Diagram 18.

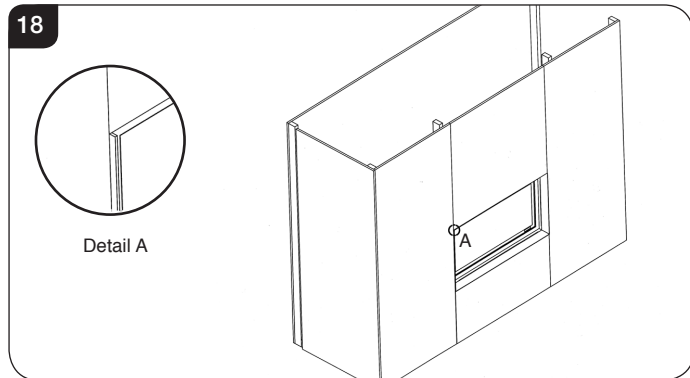

- 5.13 Apply a plaster finish to the chimney breast using heat resistant plaster in the area directly above the appliance.

Edge+ Frame

- 5.14 The Edge+ is an optional extra which consists of a decorative frame that is fitted after the studwork or chimney breast has been finished to the Edge frame.
- 5.15 Offer the base of the frame to the finished edge around the appliance. The raised magnetic holders on the Edge+ frame locate at the bottom of the opening, see Diagram 19.

Push the base of the frame half way onto the edge.

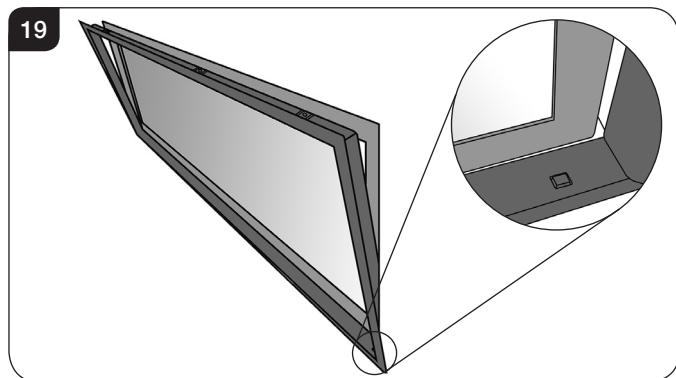

- 5.16 Push the top into place within the opening, taking care not to damage the frame or the wall finish, see Diagram 20.

Push the frame all the way onto the edge around the appliance.

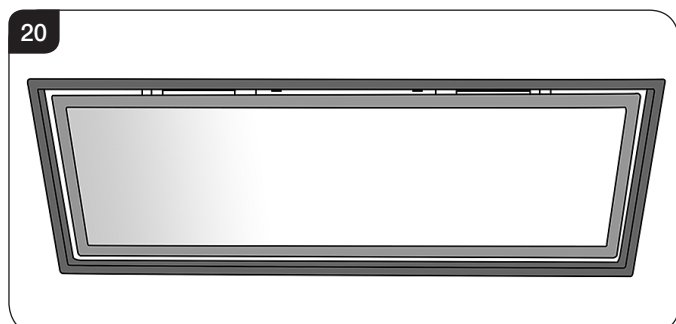

- 5.17 The installation is now complete.
- 5.18 If there is difficulty fitting the Edge+ frame it can be adjusted to suit the installation.

On the top edge of the frame are three adjustable tabs, see Diagram 21.

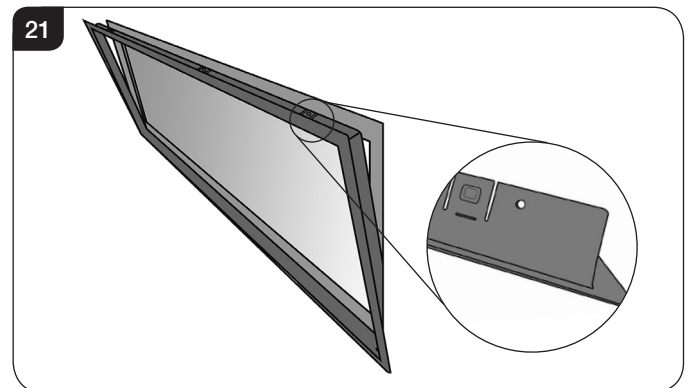

- 5.19 If the Edge+ is too loose the tabs can be bent up to gain better purchase on the edge of the appliance box. If the Edge+ is too tight the tabs can be bent downwards to give more clearance.

6. Studwork for Cool Wall installation kit

For this cool-wall installation, the convected heat produced by the appliance is channelled into the chimney cavity and vented at the top.

The cool wall installation kit is provided unfinished. This allows the kit to be finished to match the front face decor.

There is an optional Studio Cool Wall Installation Kit available for installing the appliance without a frame.

Using the fixing kit:

- 6.1 Fit the four metal brackets of the kit to the appliance, see Diagram 22. There is a deliberate gap at the top for convected heat.

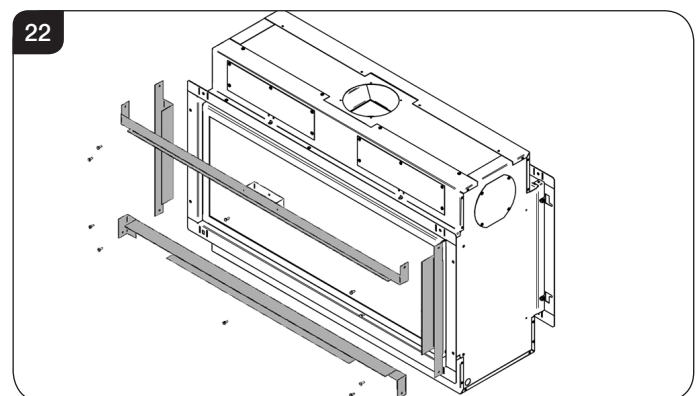

Installation Instructions

- 6.2 This now determines the width of your two vertical studwork supports. The kit has been designed so that non-combustible board can be taken right up to the edge of the four brackets, see Diagrams 23 & 24.

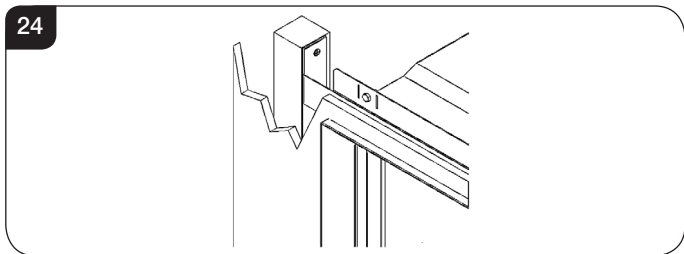
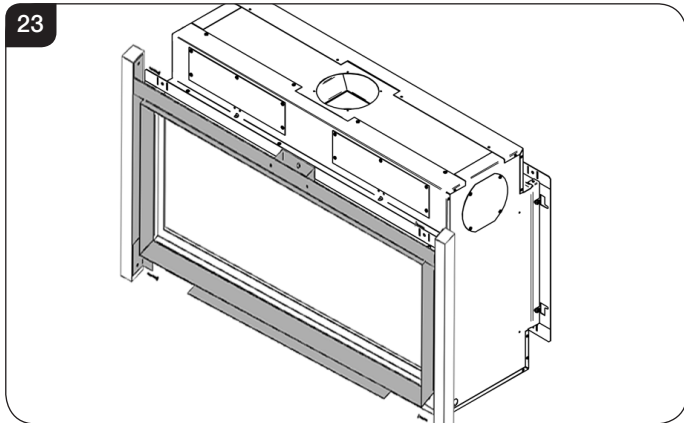

- 6.3 Fix the left and right metal brackets into the studwork. Build the studwork chimney breast to the desired size.
- 6.4 Ensure all clearances to combustible material are maintained, see Section 3.1.
- 6.5 Decide on flue requirements.
- 6.6 Fit non-combustible board to the studwork above the appliance. This should extend a minimum of 400mm above the appliance.
- 6.7 Fit plasterboard to the remaining chimney breast front.
- 6.8 Connect the flue system and gas services using the opening in the side of the chimney breast for access.
- 6.9 After commissioning, finish the sides of the chimney breast, see Diagram 25.

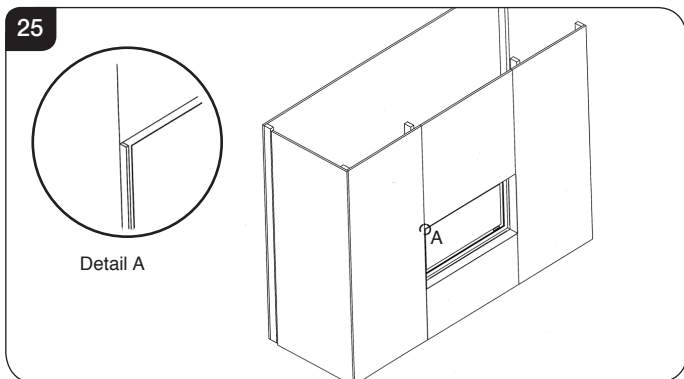

- 6.10 The top of the chimney breast must have a minimum 200cm² vent.
- 6.11 Apply a plaster finish to the chimney breast.

7. All types of Installation - Wall Box & Batteries

i Please note: As an optional extra Gazco can provide a mains adapter to supply constant power to the appliance control box instead of the battery pack.

If installing an appliance with the adapter make provision for a mains power socket within 1.5m of the control box and follow the instructions provided.

When installing the wall box allow at least 100mm of slack wire in the battery lead where it enters the appliance on the right hand side. This allows the removal of the control assembly during servicing.

- 7.1 Decide on the position for the wall box containing the batteries and wall plate and cut the necessary hole.

A battery power supply cable is supplied and pre-fitted to the appliance control. Provision is made for the cable to exit either the left or right of the appliance through the grommet. The cable is 3 metres long.

- 7.2 Connect the wire from the appliance to the battery pack, see Diagram 26.

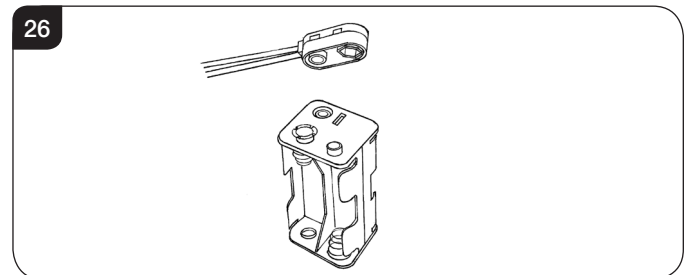

- 7.3 Correctly position the four new AA size batteries and re-assemble the battery holder as shown, see Diagram 27.

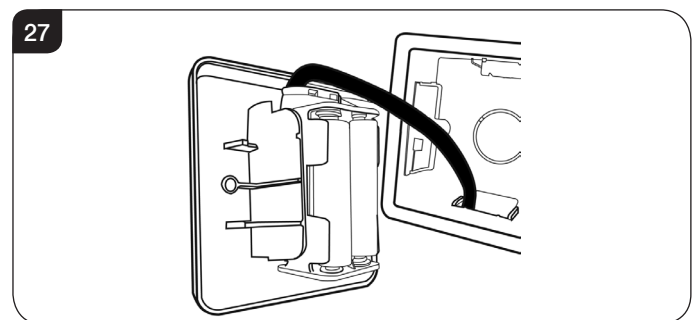

i It is essential to use high quality batteries (Duracell or equivalent) when replacing batteries in the handset or control box.

Installation Instructions

- 7.4 Secure the wall plate to the wall box using the two fixing screws, see Diagram 28.

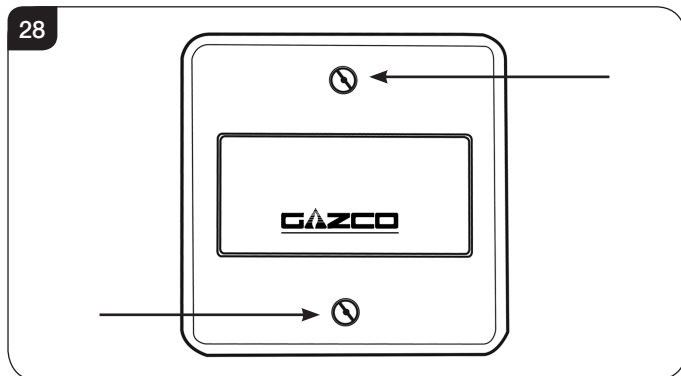

IMPORTANT
The wall plate must be installed using a non-metallic mounting box, please ensure that the plastic dry lining box is used wherever possible. If it is intended to install the wall plate into masonry it is possible to drill through the rear of this box and secure in position using wall plugs and screws although a small amount of finishing work will be required to cover the plastic side securing tags. Alternatively a standard 47mm deep pattress box can be used to surface mount the wall plate.

PLEASE ENSURE NO WIRES ARE TRAPPED BEFORE REPLACING THE WALL PLATE. THE LEAD IS EASILY DAMAGED.

8. Flue Assembly

- 8.1 See Site Requirements, Section 2, Flue Options.

TAKE CARE WHEN MARKING OUT FOR THE FLUE AS IT IS DIFFICULT TO MOVE AFTER INSTALLATION. IF A RESTRICTOR IS REQUIRED FIT THIS BETWEEN THE SMALL OUTLET SPIGOT AND THE AIR DUCT, SEE DIAGRAM 29. REFER TO TECHNICAL SPECIFICATIONS FOR RESTRICTOR SIZE.

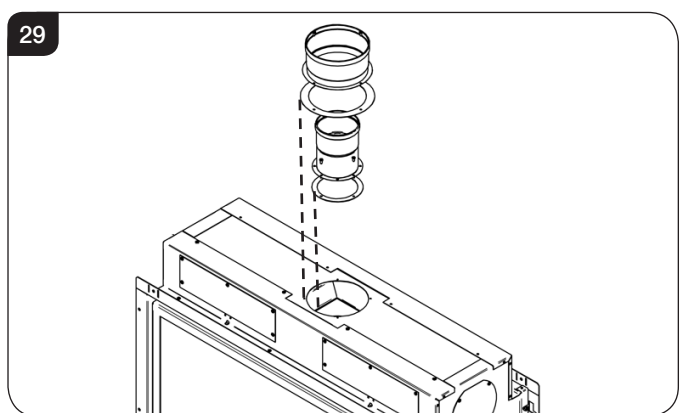

- 8.2 A 152mm (6") diameter hole in the wall is required to install the flue. This can be achieved by using either:
- a) Core drill
 - b) Hammer and chisel

- 8.3 Drill small holes around the circumference when using method b). Make good both ends of the hole.
- 8.4 Allow enough room either above or to the side of the appliance to assemble the flue on top.
- 8.5 Assemble a horizontal flue in the following order:
- Vertical section
 - 90° elbow
 - Horizontal plus terminal
- 8.6 Support the opening of a masonry installation with a lintel.
- 8.7 Only the horizontal terminal section can be reduced in size.
- To find the length:
- 8.8 Measure from the outside of the wall to the stop on the 90° elbow.
- 8.9 **Add 10mm to the outlet end.**
- 8.10 Measure from the edge of the slots closest to the wall.
- 8.11 Mark around the flue, see Diagram 30.

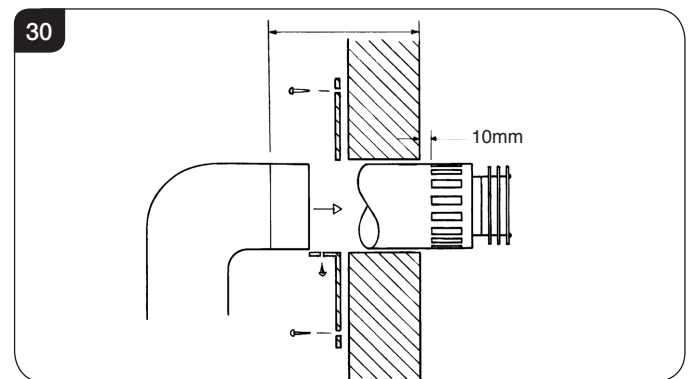

A wall plate is supplied to fix the flue to the wall:

- 8.12 Bend the tab to 90°.
- 8.13 Assemble the plate onto the flue but do not secure to wall until the flue is fully assembled, see Diagram 30.
- 8.14 The cardboard fitment in the terminal is used to support the flue whilst it is cut to length. **ONCE CUT TO SIZE REMOVE THE CARDBOARD REMNANT**, see Diagram 31.

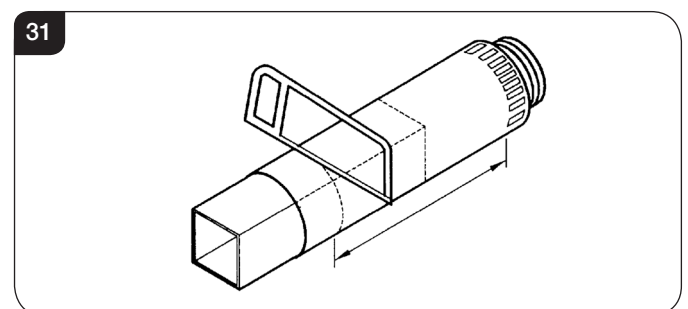

- 8.15 Remove the compression elbow from the appliance and connect it to the gas supply pipe.

Installation Instructions

As the appliance is fitted into the enclosure:

- 8.16 Pass the elbow and supply pipe through the silicone panel on the LEFT HAND side.
- 8.17 **PURGE THE SUPPLY PIPE.** This is essential to expel any debris that may block the gas controls.
- 8.18 Connect the elbow to the appliance inlet pipe, see Diagram 32.

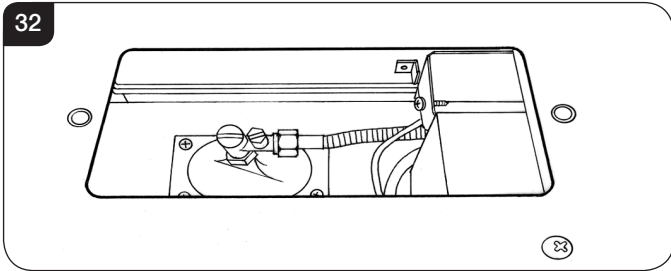

- 8.19 Connect a suitable pressure gauge to the test point located on the inlet fitting.
- 8.20 Turn on the gas.
- 8.21 Light the appliance and check for leaks.
- 8.22 Turn the appliance to maximum and check that the supply pressure is as stated on the data badge.
- 8.23 Turn off the gas and replace the test point screw.
- 8.24 Turn the gas back on and check the test point for leaks.

9. Assembling the Appliance

The Log Effect Studio Duplex has the option of two different liner finishes:

Vermiculite
Black Reeded

- 9.1 Fit the lower liners around the burner tray, see Diagram 33.

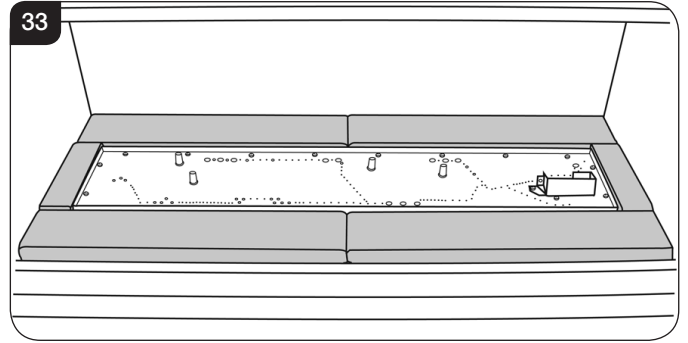

- 9.2 Fit the side liners, see Diagram 34.

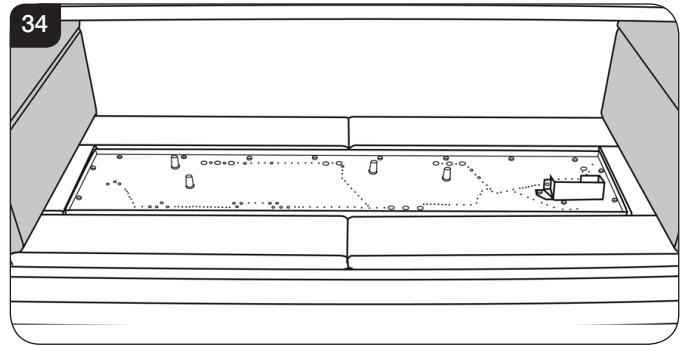

Installation Instructions

10. Arrangement of the fuel bed

Advice on handling and disposal of fire ceramics



The black reeded liners are made from Refractory Ceramic Fibre (RCF), a material which is commonly used for this application.

Protective clothing is not required when handling these articles, but we recommend you follow normal hygiene rules of not smoking, eating or drinking in the work area and always wash your hands before eating or drinking.

To ensure that the release of RCF fibres are kept to a minimum, during installation and servicing a HEPA filtered vacuum is recommended to remove any dust accumulated in and around the appliance before and after working on it. When servicing the appliance it is recommended that the replaced items are not broken up, but are sealed within heavy duty polythene bags and labelled as RCF waste.

RCF waste is classed as stable, non-reactive hazardous waste and may be disposed of at a licensed landfill site.

Excessive exposure to these materials may cause temporary irritation to eyes, skin and respiratory tract; wash hands thoroughly after handling the material.

10.1 **Vermiculite for Log Layout:** Use the entire bag of supplied Vermiculite.

TAKE CARE NOT TO SPILL VERMICULITE INTO THE PILOT AREA. ONLY USE THE FUEL EFFECT SUPPLIED BY GAZCO IN THIS APPLIANCE.

11. Log Layout

LOGS MUST BE POSITIONED ACCORDING TO THE FOLLOWING INSTRUCTIONS TO GIVE THE CORRECT FLAME EFFECT.

11.1 In order to install the correct log layout the pilot burner must be situated on the bottom right hand side of the appliance, see Diagram 35.

All logs can be identified by a letter (A - I) on their underside. The first 2 logs, A and B, also have holes to locate each onto a burner stud.

11.2 Working from left to right place logs A and B onto their studs on the burner tray, see Diagram 35.

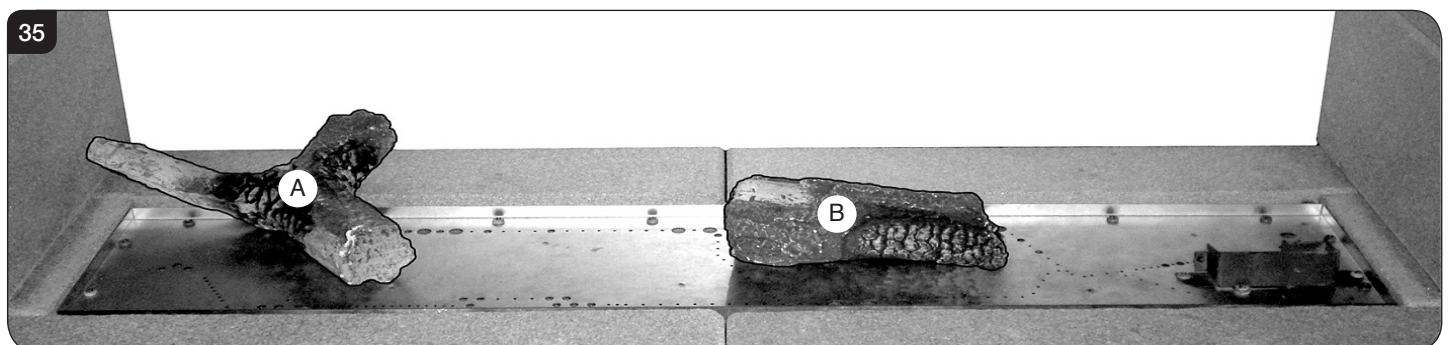

11.3 Use all the vermiculite to fill the burner tray between Logs A and B. Spread evenly across between the logs, so the whole burner is covered, see Diagram 36.

Ensure not to drop vermiculite down the edges of the burner tray.

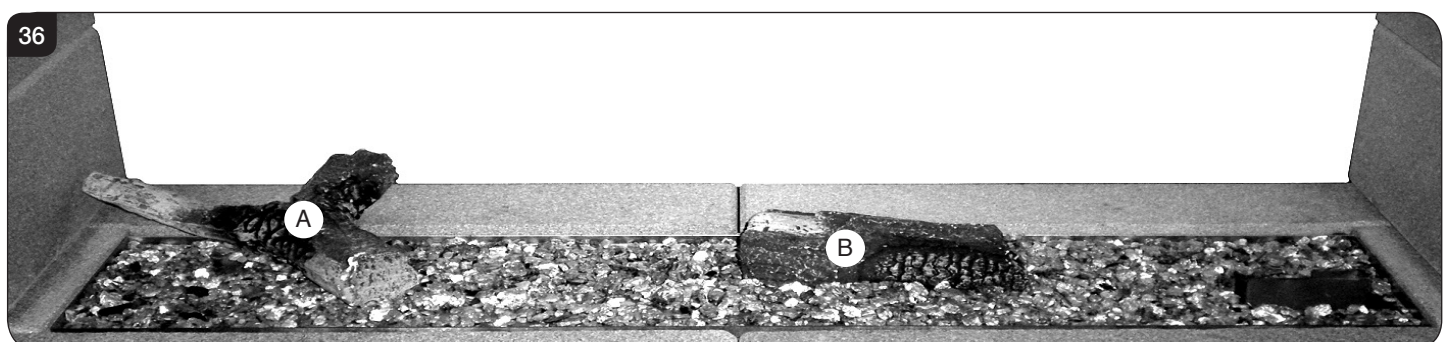

Installation Instructions

Diagram 37 shows the layout of logs C and D.

- 11.4 Place the front end of Log C on the front left panel and rest the rear end across Log A.
- 11.5 Place the front end of Log D along the front panel with the bend curving backwards with the rear end resting on Log B.

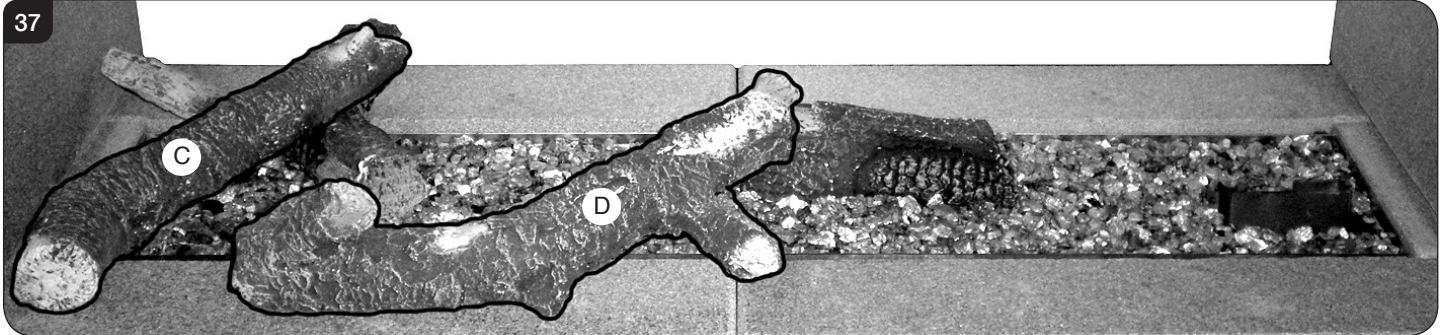

Diagram 38 shows the layout of logs E and F.

- 11.6 Place the back end of Log E on the back panel and rest the front end across Log D.
- 11.7 Place the front end of Log F onto the front right panel and rest the back end across Log B.

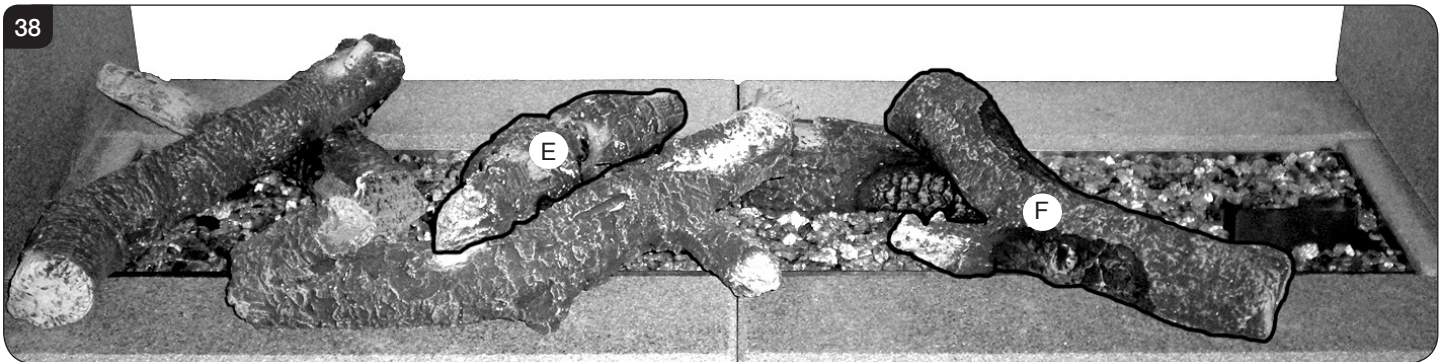

Diagram 39 shows the layout of log G.

- 11.8 Place the back end of Log G on the back right hand panel and rest the front end onto Log F.



Installation Instructions

Diagram 40 shows the layout of logs H and I.

- 11.9 Place the front end of Log H onto the front right panel and against the right side panel.
- 11.10 Place the back end of Log I on the back right hand panel and rest the front end onto Log B.

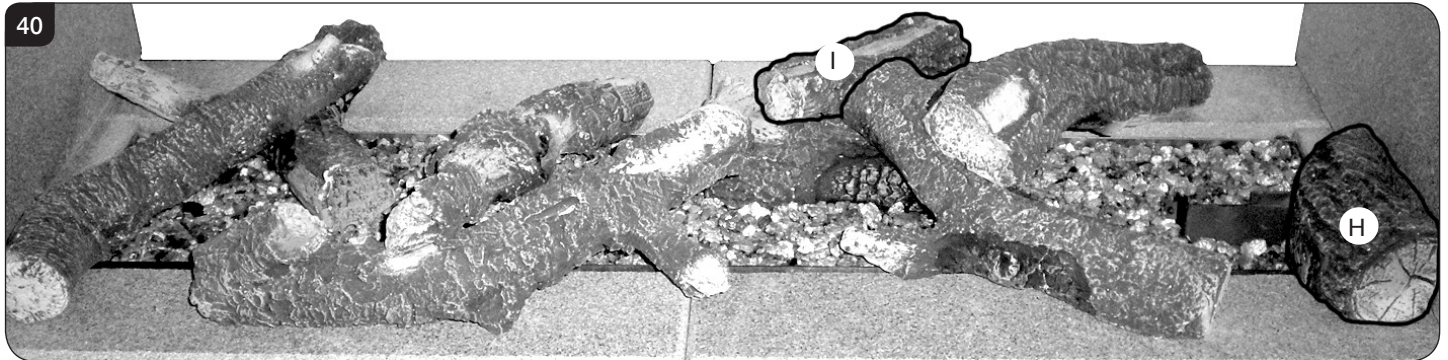

- 11.11 Separate the Embaglow material into smaller pieces and pull into shape to create a fine layer.
- 11.12 Sparingly spread an amount of the Embaglow fibres provided, covering the ports in the burner tray, see Diagram 41. Ensure the material is placed loosely to create a random glow. Take care not to use more than half a packet per application.
WARNING - DO NOT PLACE NEAR THE PILOT AREA.

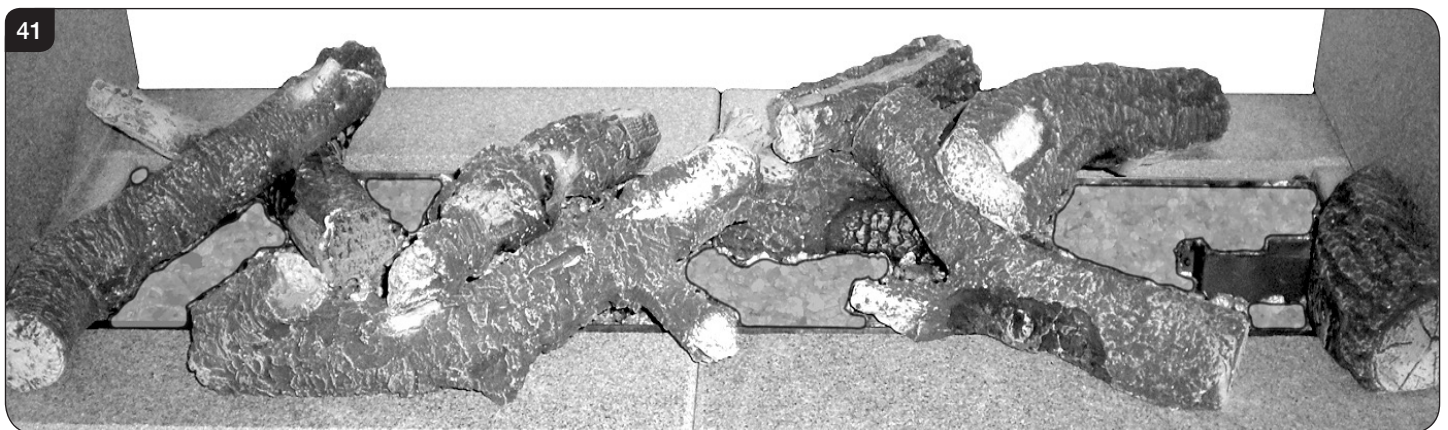

12. Completion of assembly

- 12.1 To fit the window frame keep the frame in the upright position with the locks uppermost.
- 12.2 Offer the frame to the foot of the opening.
- 12.3 Slide the frame to the right to locate the right hinge pin.

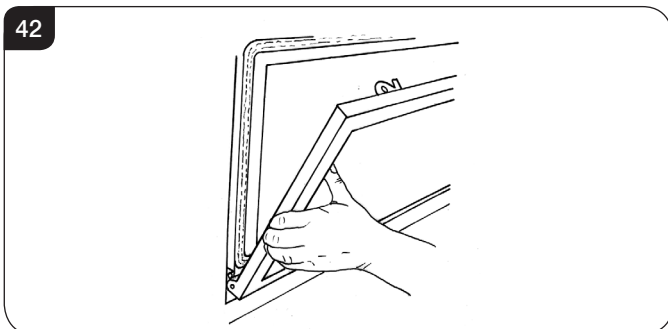

- 12.4 Manoeuvre the frame up towards the left side to locate the left hinge pin.

- 12.5 Slide onto the hinge with a right movement.

- 12.6 Secure in place with a spring clip at the right hinge pin, see Diagram 43.

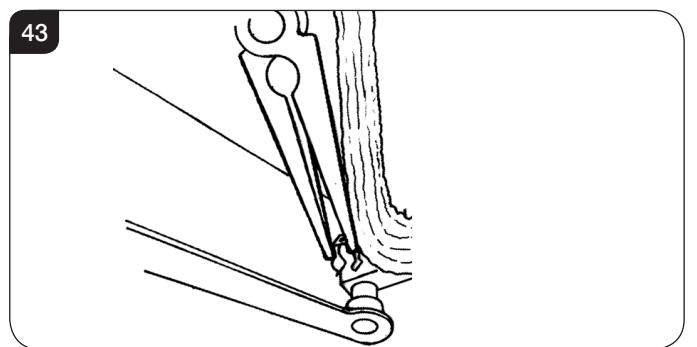

- 12.7 Close the window.

Installation Instructions

12.8 Using the hexagon key provided close the window locks by moving from open to shut towards the window centre, see Diagram 44.

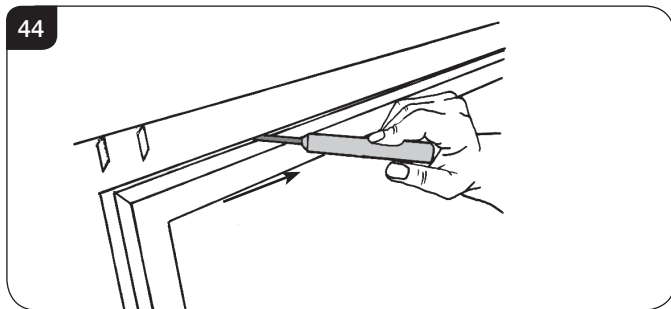

12.9 When closing the door ensure the door catches are fully engaged.

! UNDER NO CIRCUMSTANCES SHOULD THE APPLIANCE BE USED WITHOUT THE CATCHES HOLDING THE DOOR IN PLACE.

13. Decorative Frame

The fitting of the frame requires 2 people

To attach the frame:

13.1 Rest the lower fixing angle of the frame onto the bottom brackets attached to the appliance flange.

13.2 Lift the upper angle onto the top brackets and lower, see Diagram 45.

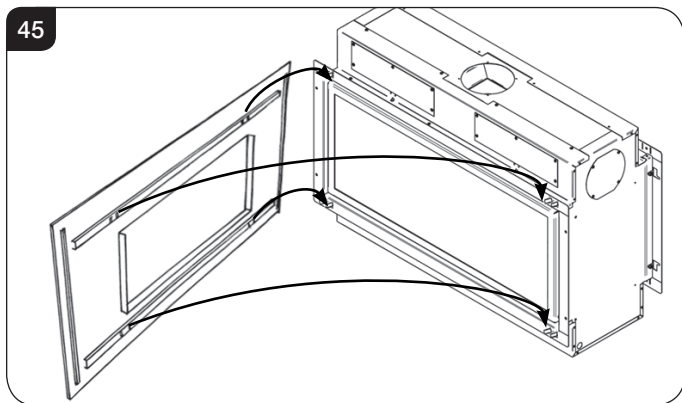

14. Lighting the Appliance

The appliance is operated by thermostatic remote control.

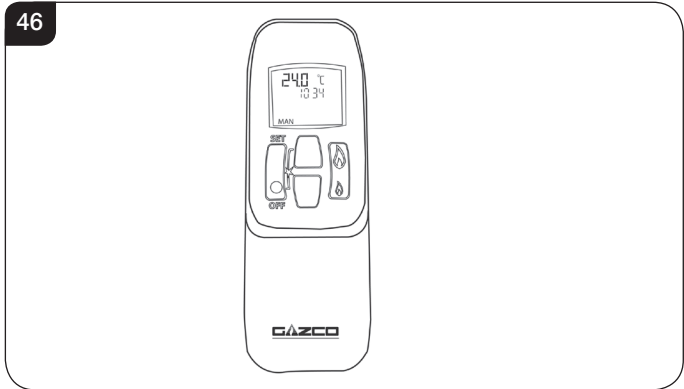

This remote controls the appliance from pilot ignition through to shut down.

In 'MANUAL MODE' you can:

- light the pilot
- turn on the main burner
- regulate the flame from low to high and back
- turn off the burner leaving just the pilot burning

In 'TEMP MODE' you can:

- set the room temperature so the stove automatically maintains that temperature

In 'TIMER MODE' the fire:

- turns on and off according to the set time periods
- automatically regulates the room temperature during the set periods

14.1 Turning the appliance On

Your remote can control the gas fire from pilot ignition through to shut down.

To turn the fire on press the OFF button and the UP button simultaneously. You hear several short signals.

The pilot and main burner ignite and the remote is now in Manual Mode:

Turning the appliance Off:

Press the OFF button to turn the appliance off.

FOR SAFETY, YOU MUST WAIT 30 SECONDS BEFORE LIGHTING THE FIRE AGAIN.

i IMPORTANT: YELLOW FLAMES TYPICALLY APPEAR WHEN THE APPLIANCE HAS REACHED NORMAL OPERATING TEMPERATURE. THIS CAN TAKE UP TO 30 MINUTES.

! WARNING: IF THE APPLIANCE FAILS TO LIGHT OR BECOMES EXTINGUISHED IN USE, WAIT 3 MINUTES BEFORE ATTEMPTING TO RELIGHT.

FOR FULL OPERATING INSTRUCTIONS AND TROUBLESHOOTING SEE USER SECTION.

Installation Instructions / Commissioning

Troubleshooting



IMPORTANT: In the unlikely event that the handset fails to communicate correctly with the appliance it may be necessary to turn off the gas supply at the isolation valve until any problems can be resolved.

The gas meter and isolation valve can be located outside in a meter box, under the stairs, beneath the kitchen sink or in the garage. Whilst this list is not exhaustive, it is important to be able to identify the location of the valve in case of any gas emergency.

To turn off the gas supply, simply turn the handle so the lever is at 90 degrees to the upright gas pipe.

If you smell gas, open doors and windows and never operate any electrical switches. Immediately call the Gas Emergency Services on 0800 111 999.

1. Commissioning

- 1.1 Complete the Commissioning Checklist at the front of this manual covering:
 - Thermocouple soundness checks.
This is to include ensuring the thermocouple is secure on the pilot bracket assembly, lead connection and integrity.
 - Flue checks
 - Gas checks
 - Log layout - flame picture

For working pressure test, use the access panel at the gas connection ensuring the burner is in position. Refer to Replacement Parts, Section 16.
- 1.2 Ensure all safety checks listed in the Commissioning Section are completed, paying particular attention to the glass panel checks and securing of the glass frame.
- 1.3 Upon completion of the commissioning and testing of the installation and correct operation of the appliance, the installer must instruct the user how to operate the appliance.
- 1.4 Guide the user through the User Instructions paying particular attention to:
 - a) Regular servicing (Section 9 of the User Instructions).
 - b) Ventilation (Section 10 of the User Instructions) - point out the ventilation positions where applicable.
 - c) Hot surfaces (Section 12 of the User Instructions).
 - d) How the appliance works with the remote control handset and the modes of operation (Section 2 of the User Instructions).
 - e) How to change settings in the auto mode and program modes of operation.
 - f) What to do if the appliance fails to operate (Section 13 of the User Instructions).

Reprogramming handset/Control box

To access the control box see Servicing Instructions, Section 7 - Main Control Assembly.

- Press and hold the reset button on the control box until you hear two signals. After the second longer signal:
- Release the reset button and within 20 seconds:
- Press the DOWN button on the handset until you hear two additional short signals confirming the new code is set.
If there is a single long signal the code learning sequence has failed or the wiring is incorrect.

Servicing Instructions

Servicing/Fault Finding Charts

1. Servicing Requirements

IMPORTANT – The glass panel on this appliance should be checked for any signs of damage on the front face of the glass panel (scratches, scores, cracks or other surface defects). If damage is observed, the glass panel must be replaced and the appliance must not be used until a replacement is installed. Under no circumstances should the appliance be used if any damage is observed. Please isolate the appliance until a replacement glass panel has been obtained and installed. Replacement glass panels can be purchased from Gazco via the retailer from which the appliance was purchased or any other Gazco distributor.

This appliance must be serviced at least once a year by a competent person.

All tests must be carried out in accordance with the current GasSafe recommendations.

1.1 Before Testing:

- Conduct a gas soundness test for the property ensuring there are no leaks before servicing.
- Check the operation of the appliance before testing.

1.2 Special checks:

- Clean the burner using a vacuum cleaner with a soft brush attachment. Ensure all debris is removed from the burner ports.

- Clean away lint or fluff from the pilot.
- Clean away lint or fluff from under the burner.
- Check the spark gap on the pilot is correct.

1.3 Correct any faults found during the initial test.

1.4 Re-commission the appliance in accordance with Commissioning Procedures of these instructions.

1.5 Advise the customer of any remedial work undertaken.

REPLACE BATTERIES BEFORE ATTEMPTING TO RECTIFY ANY FAULTS.

ELECTRONIC CONTROL VALVE FAULT ANALYSIS

Symptom	Cause	Remedy
Frequent beeps for 3 seconds after operation request	Batteries low in appliance	Replace appliance batteries
No ignition, 5 second continuous tone (there may be several short beeps before)	Loose/damaged wire	Check interrupter block and wires
No ignition, no tone, motor turns slightly when operated	Receiver board damaged	Replace receiver
No pilot flame and control continues to spark	Thermocouple circuit wired incorrectly	Correct wiring
Pilot lights, control continues to spark, valve shuts down after 10 - 30 seconds	1. No spark at pilot burner 2. Loose/damaged wire	1. Rectify spark at pilot burner 2. Check interrupter and wires

IGNITION FUNCTIONAL CHECK 1

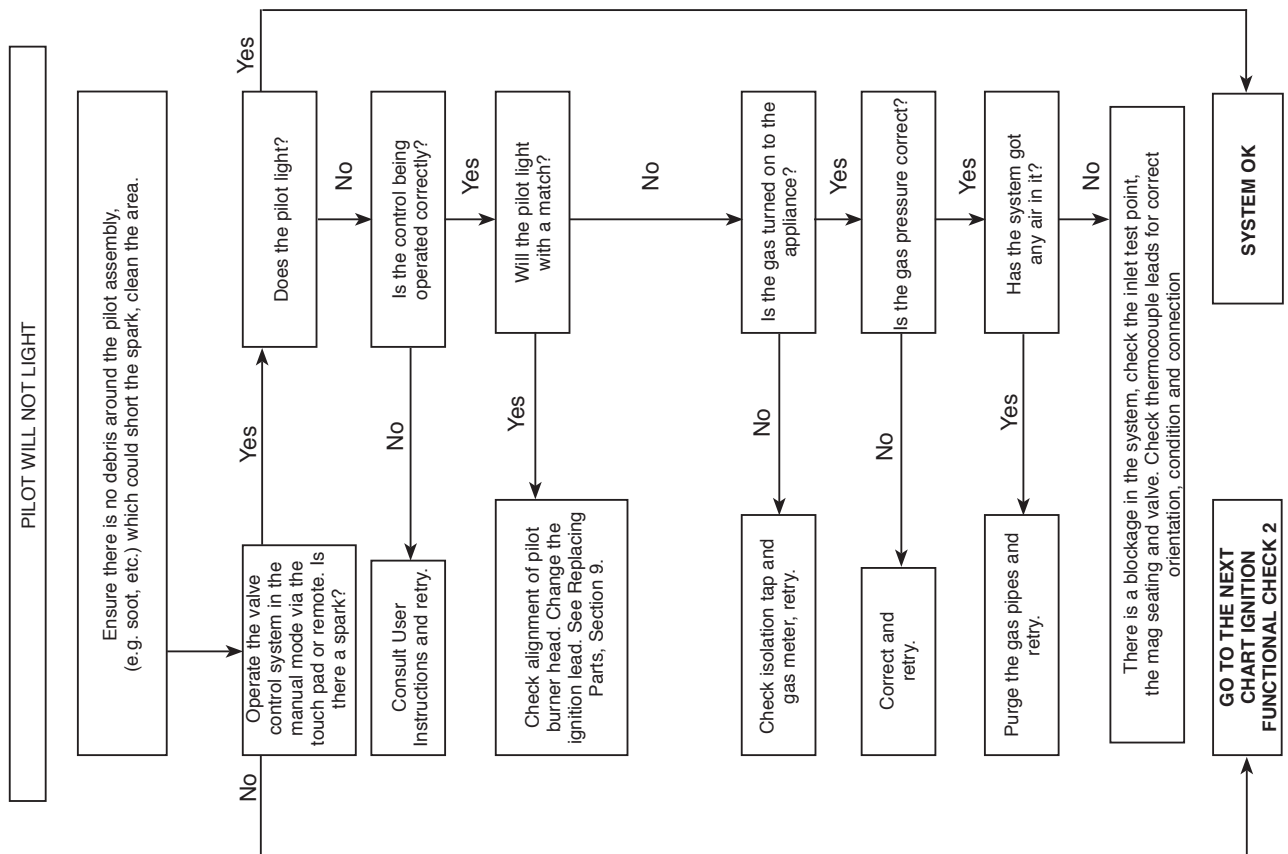

Servicing Instructions

Fault Finding Charts

FLAME FAILURE FUNCTIONAL CHECK 3

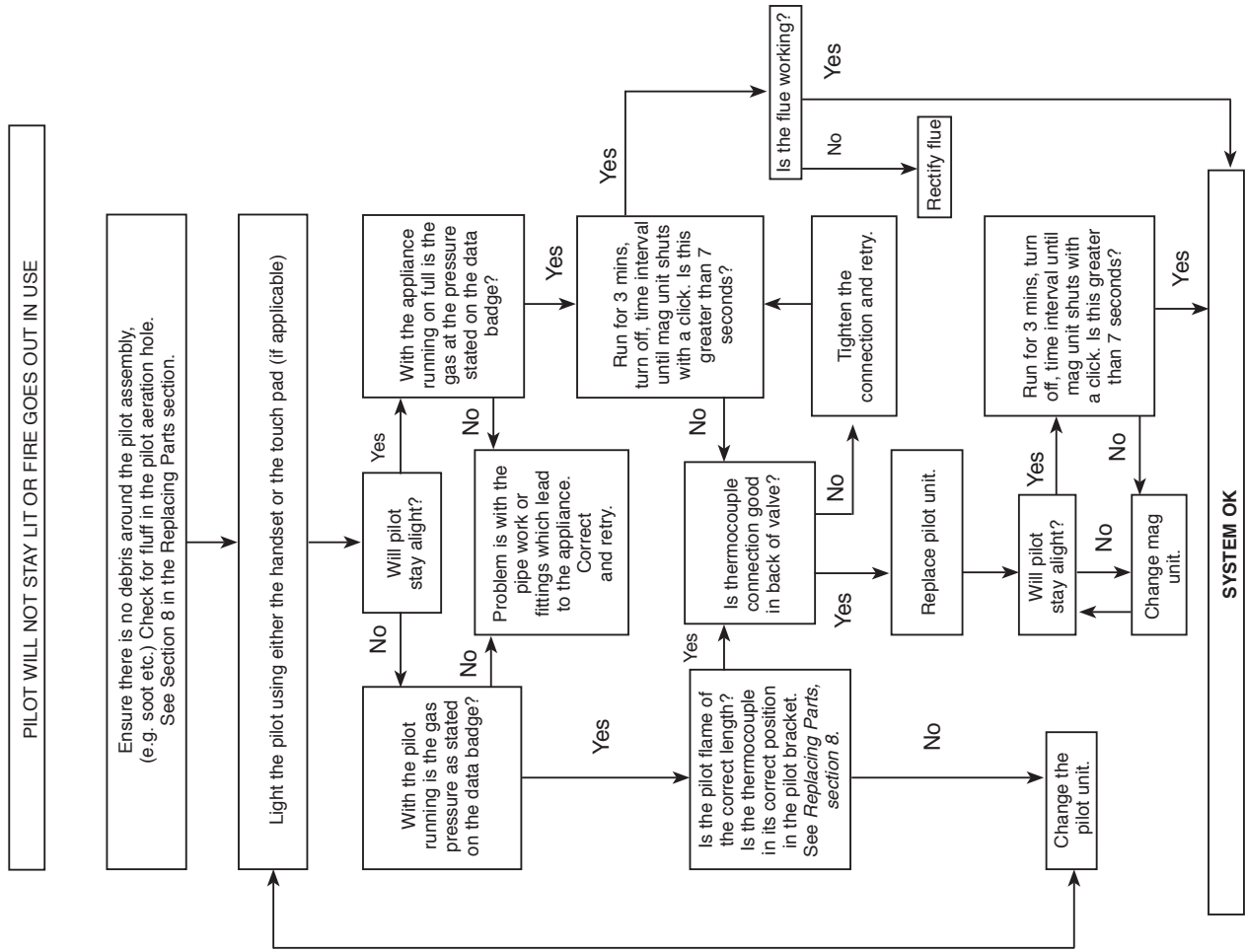

IGNITION FUNCTIONAL CHECK 2

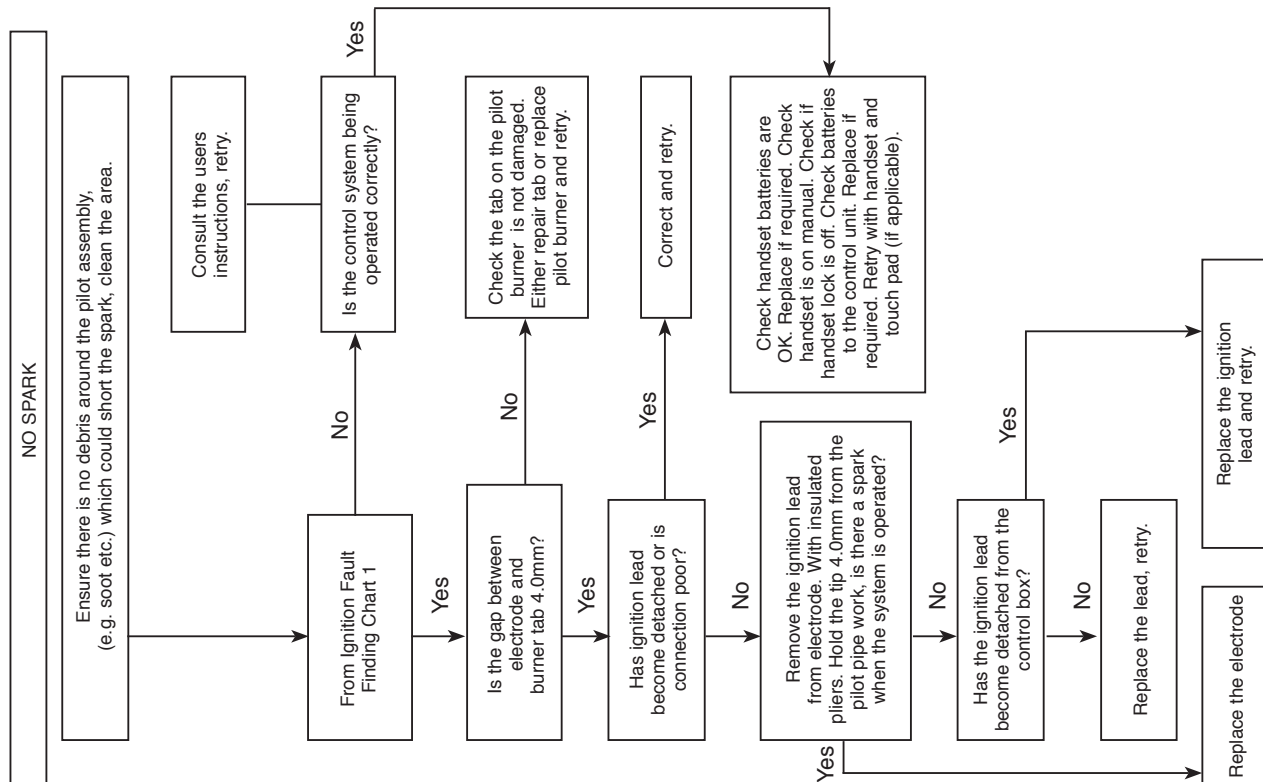

Servicing Instructions - Replacing Parts

1. General

- 1.1 All main components can be replaced without removing the appliance from its installation.

IT IS ESSENTIAL THAT THE GAS SUPPLY TO THE APPLIANCE IS TURNED OFF AT THE ISOLATION DEVICE BEFORE PROCEEDING FURTHER.

- 1.2 **DISCONNECT BATTERIES BEFORE SERVICING THE APPLIANCE.**

Removal of Flue

- 1.3 **If, for any reason, the flue has to be removed from the appliance, the seal must be replaced in the inner spigot.**
- 1.4 Access to the controls is restricted and the whole control assembly must be removed as one unit, see Section 7.

2. Decorative Frame

The same method is used to remove each frame.

- 2.1 Lift the frame upwards off the four support brackets, see Diagram 1.

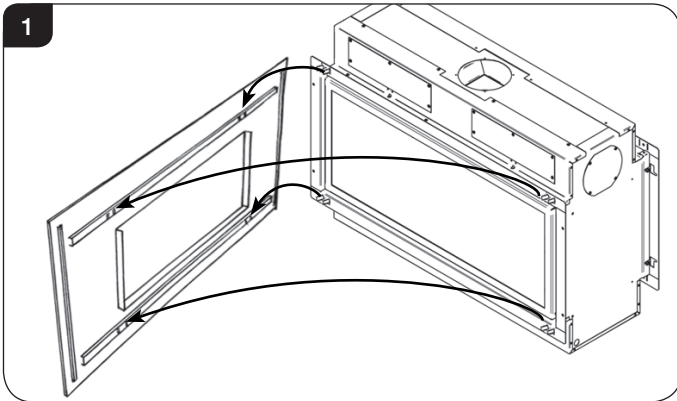

NOTE: THE STEEL FRAME IS HEAVY. TAKE CARE WHEN LIFTING.

3. Window Frame Assembly

- 3.1 To open the glass door use the hexagon key provided.
- 3.2 Release the window locks by moving them from shut to open towards the outer edges, see Diagram 2.

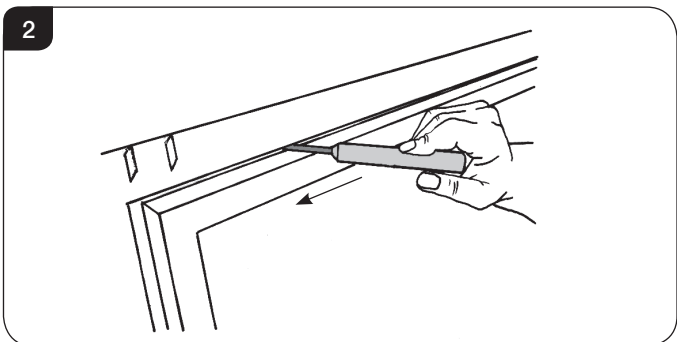

- 3.3 To completely remove the glass front:
- 3.4 Support the frame and lower it gently forward down to its natural stop position, see Diagram 3.
DO NOT EXERT PRESSURE ON THE DOOR ONCE THERE IS RESISTANCE.

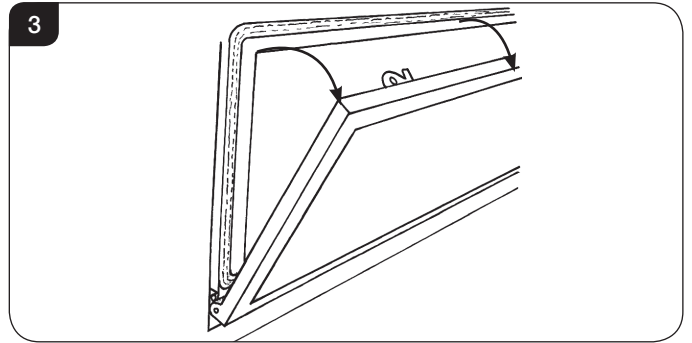

- 3.5 Remove the securing spring clip from the bottom-right of the window frame, see Diagram 4.

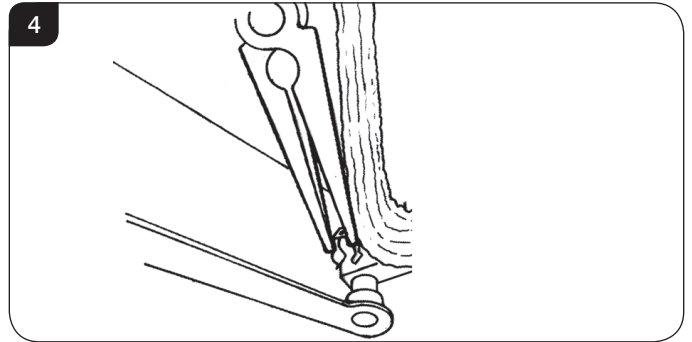

- 3.6 With the window frame in an upright position slide the frame to the left so that it comes off the left hinge pin, see Diagram 5 (1).
- 3.7 Still keeping the frame upright drop the left side down and forward slightly, see Diagram 5 (2).

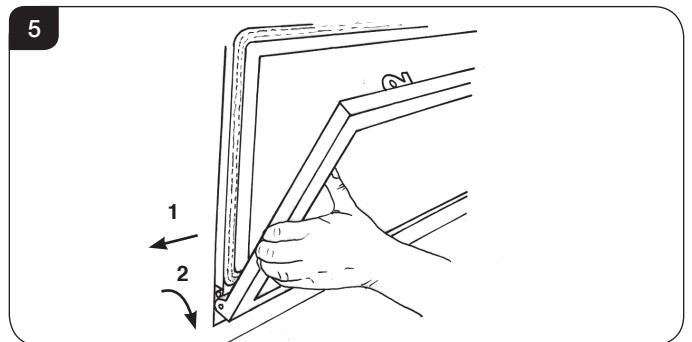

- 3.8 Slide the frame to the right so it comes off the right hinge pin. The window frame should now be free.
- 3.9 Refit the Window Frame Assembly in reverse order.

When closing the door ensure the door catches are fully engaged.



UNDER NO CIRCUMSTANCES SHOULD THE APPLIANCE BE USED WITHOUT THE CATCHES HOLDING THE DOOR IN PLACE.

Servicing Instructions - Replacing Parts

4. Glass Window

- 4.1 Remove the two clips and brackets from either side of the frame, see Diagram 6.

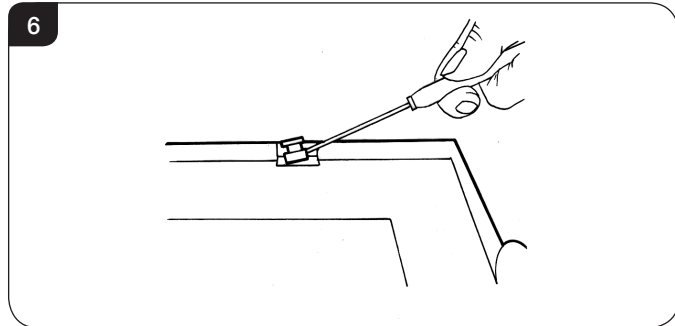

- 4.2 Lift the glass clear from the lock bracket at the top of the frame and slide out.

5. Liners for Studio Duplex

5.1 Removing of the Liners

The Log Effect Studio Duplex has the option of two different liner finishes:

Vermiculite
Black Reeded

- 5.2 Remove the side liners, see Diagram 7.

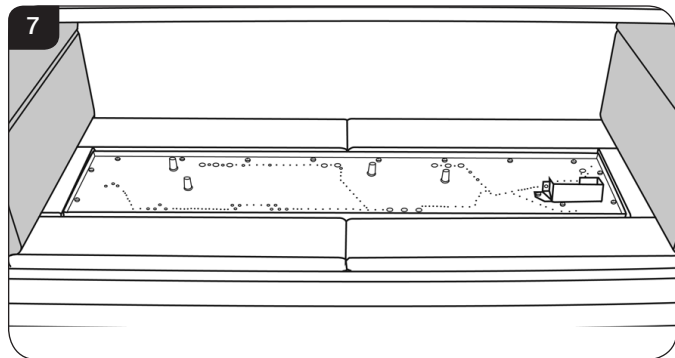

- 5.3 Remove the lower liners around the burner tray, see Diagram 8.

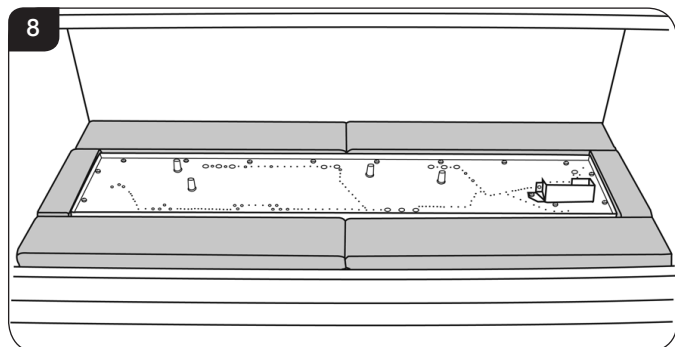

- 5.4 This allows access to the main burner, see Diagram 9.

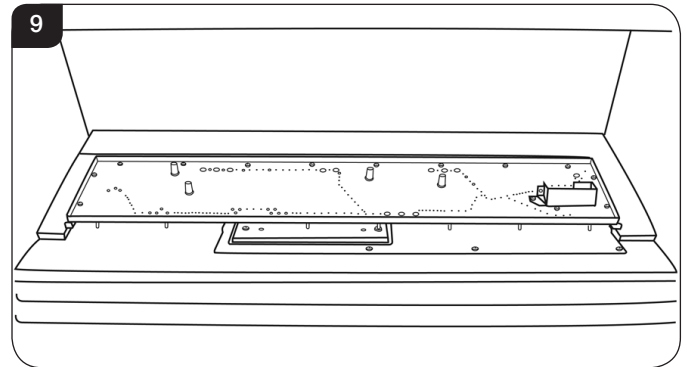

- 5.5 Replace in reverse order.

6. Main Burner

To replace the main burner:

- 6.1 Remove the fuel effect from the burner (optional).
6.2 Remove the liners/panels.
6.3 Remove the burner securing screw from the left side of the burner, see Diagram 10.

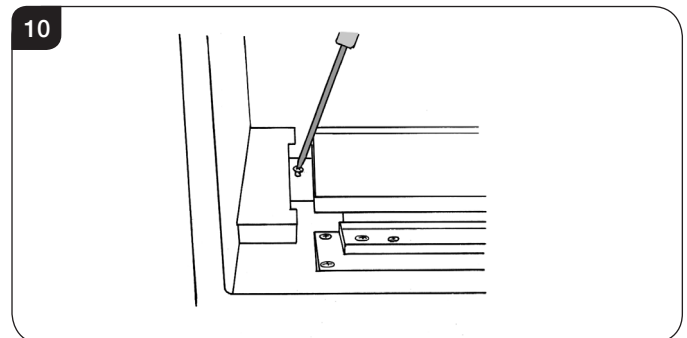

- 6.4 Slide the burner fully to the left and lift the right side clear of the pilot, see Diagram 11.

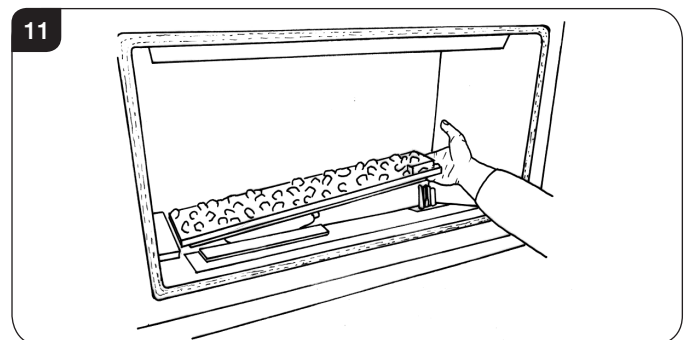

- 6.5 Slide the burner to the right and out of its location.
6.6 Refit in reverse order.
Ensure no fuel effect falls into the pilot area.

Servicing Instructions - Replacing Parts

7. Main Control Assembly

7.1 To access the main control assembly first remove:

- The decorative frame.
- Window frame.
- Fuel Effect.
- Liner panels.
- Main burner.

To remove the access panel:

7.2 Undo the two screws, see Diagram 12.

7.3 **Note the orientation of the access panel with the return edges facing forward.**

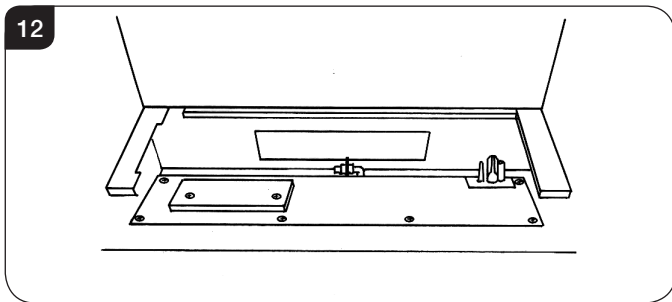

7.4 Isolate the gas supply at the isolation device and disconnect the gas inlet, see Diagram 13.

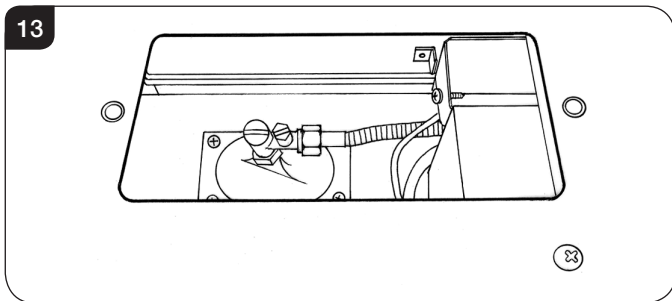

7.5 Remove the six screws securing the control assembly, see Diagram 14.

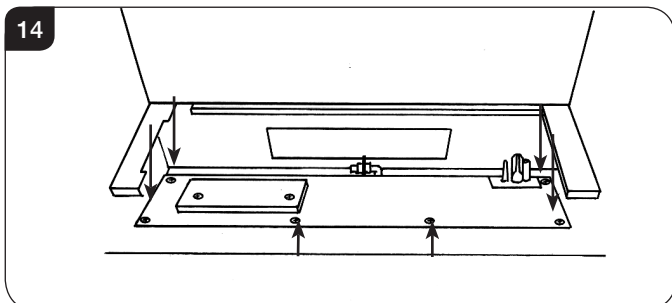

7.6 The control panel can now be tilted back to reveal the controls, see Diagram 15.

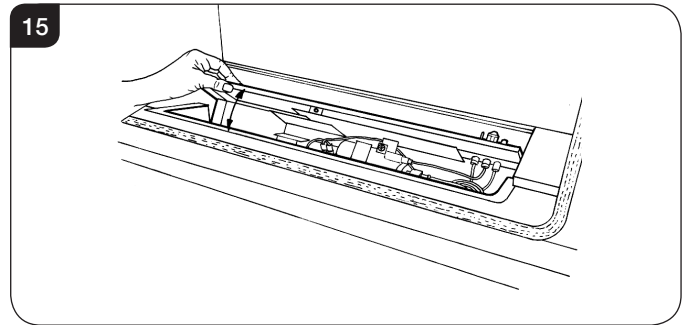

7.7 Disconnect the two cables marked 'A' in Diagram 16.

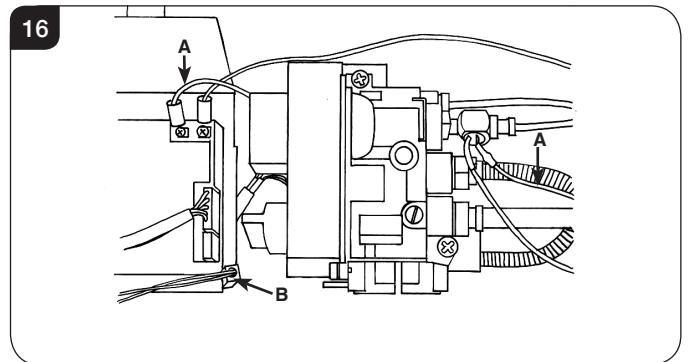

7.8 Disconnect the battery extension lead, Diagram 16, B.

The control assembly can now be lifted up and removed.

7.9 Reassemble in reverse order.

8. Pilot Unit



IMPORTANT: UNDER THE TERMS OF THE EXTENDED WARRANTY IT WILL BE COMPULSORY TO CHANGE THE COMPLETE PILOT UNIT ON THIS APPLIANCE IN YEARS 2 AND 4.

The pilot assembly consists of four components which can be individually changed:

- 8a) Pilot burner bracket.
- 8b) Electrode.
- 8c) Pilot Injector.
- 8d) Thermocouple.

8.1 Before commencing work on the pilot the Main Control Assembly must be removed, see Section 7.

8a. Pilot Burner Bracket

To remove the Pilot Burner Bracket:

- 8.2 **First remove the electrode, pilot pipe and thermocouple, see 8b and 8d.**
- 8.3 Remove the two screws securing the bracket. The pilot burner bracket can now be removed.
- 8.4 Check the pilot gasket and if damaged, replace with a new one.

Servicing Instructions - Replacing Parts

8.5 Replace in reverse order.

8b. Electrode

8.6 Pull the ignition lead off the electrode and undo the retaining nut, see Diagram 17.

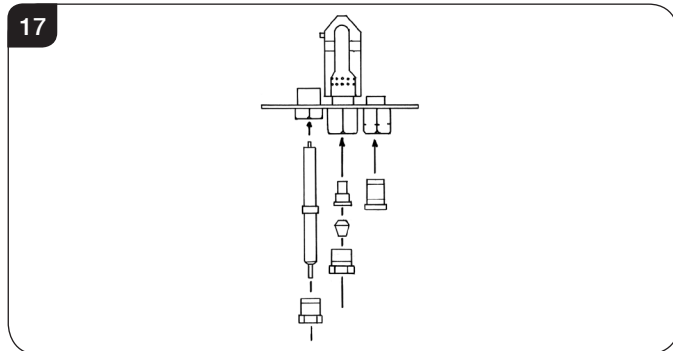

8.7 Replace with a new electrode. Do not over-tighten the nut; this could break the component.

8.8 Replace the ignition lead.

8c. Pilot Injector

8.9 Undo the pilot pipe from the gas valve and from the underside of the pilot burner, see Diagram 18, Pilot Connections.

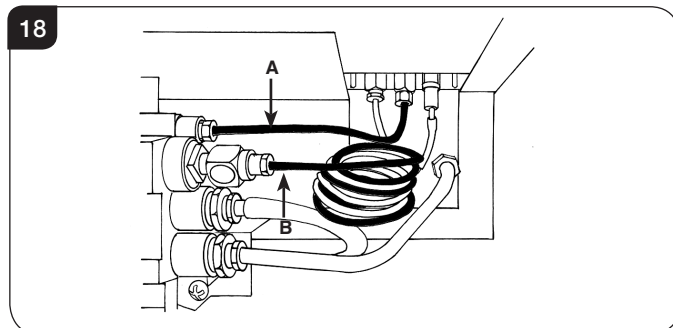

8.10 Remove the pipe and the injector drops out from the burner.

8d. Thermocouple

8.11 Disconnect the thermocouple from the gas valve/interrupter, see Diagram 18.

8.12 Undo the thermocouple nut in the back of the pilot bracket half a turn. This releases the thermocouple.

8.13 When replacing with a new thermocouple, take care to bend the new component to the same shape as the thermocouple just removed.

8.14 To refit the thermocouple into the pilot bracket, ensure it is pushed fully into the hole. There is a stop on the thermocouple to set the height.

8.15 Lock the retaining nut just enough to grip the thermocouple.

8.16 Connect the thermocouple to the valve/interrupter **taking care not to over-tighten.**

9. Ignition Lead

To replace the ignition lead:

9.1 Release the Main Control Assembly and tilt backwards, see Section 7.

9.2 Remove the ignition lead from the control box, see Diagram 19.

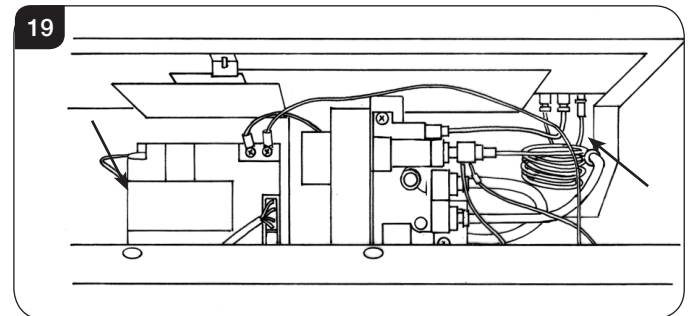

9.3 Remove the ignition lead from the electrode, see Diagram 19, removing cable ties where necessary.

9.4 **Note the direction of the lead. The new lead must follow exactly the same route. Replace cable ties where necessary.**

NOTE: THE IGNITION LEAD MUST NOT PASS IN FRONT OF THE CONTROL BOX AS THIS CAN DAMAGE THE SENSITIVE ELECTRONICS.

10. Gas Valve

To change the gas valve:

10.1 Remove the control assembly, see Section 7.

10.2 Release the gas inlet pipe, see Diagram 20 Arrow A.

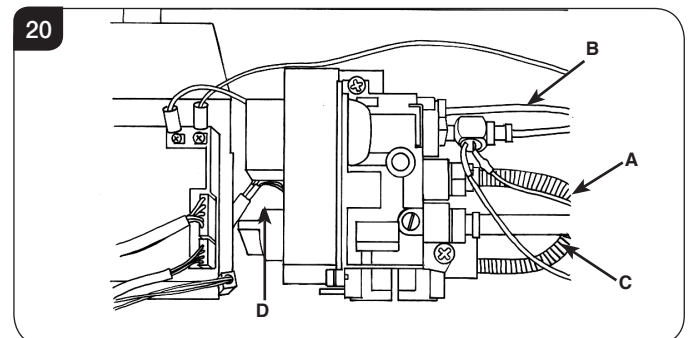

10.3 Remove the thermocouple from the interrupter block and release the second thermocurrent cables.

10.4 Release the pilot pipe, see Diagram 20, Arrow B.

10.5 Release the gas outlet pipe, see Diagram 20 Arrow C.

10.6 Remove the eight wire loom, see Diagram 20, Arrow D.

10.7 Remove the two screws securing the valve to the support bracket and withdraw the valve.

10.8 Replace in reverse order.

Servicing Instructions - Replacing Parts

11. Magnetic Safety Valve

To replace the magnetic safety valve:

- 11.1 Undo the thermocouple from the interrupter block and remove the two interrupter leads.
- 11.2 Unscrew the interrupter block from the back of the valve.
- 11.3 Undo the silver magnetic valve retaining nut on the back of the valve.
- 11.4 Gently tap out the mag valve.
- 11.5 Replace with a new unit.
- 11.6 Reassemble in reverse order ensuring that the interrupter leads are connected correctly with the blue tag lead furthest away from the gas valve body.

12. Control Box

- 12.1 To replace the control box first remove the main control assembly, See Section 7.
- 12.2 Remove the two thermocurrent cables by removing the two screws, Diagram 21.
- 12.3 Remove the ignition lead, Diagram 21.
- 12.4 Remove the eight wire loom from the control box.
- 12.5 Remove the battery extension cable, Diagram 21.

The control box can now be replaced.

When replacing the sealing plate on the rear of the control cover use a suitable silicone sealant.

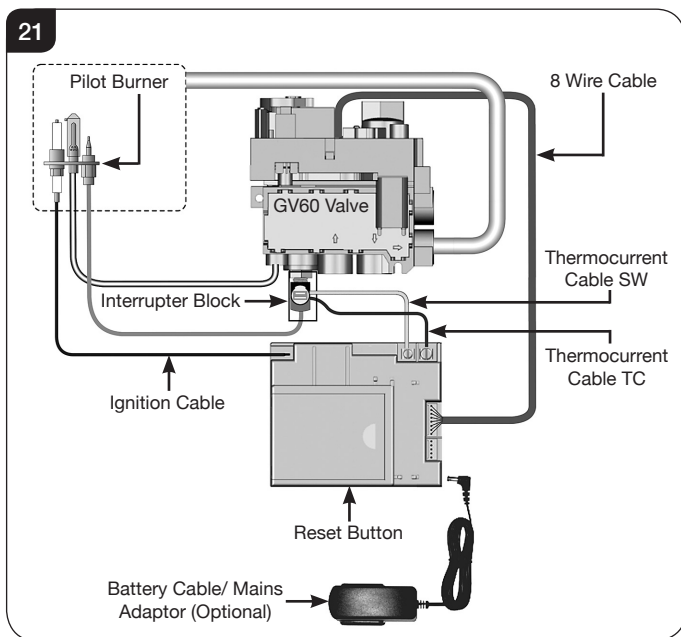

- 12.6 After replacing the control box you may need to reprogram the handset.
 - Press and hold the reset button on the control box until you hear two signals. After the second longer signal:
 - Release the reset button and within 20 seconds:
 - Press the DOWN button on the handset until you hear two additional short signals confirming the new code is set.
If there is a single long signal the code learning sequence has failed or the wiring is incorrect.

13. Main Injector

To change the main injector:

- 13.1 Undo the injector fee pipe.
- 13.2 Undo the lock nut from the injector.
- 13.3 Replace with the correct size injector.

14. Primary Aeration Plate

NOT ALL MODELS HAVE AERATION PLATES. REFER TO TECHNICAL SPECIFICATIONS, PAGE 12.

- 14.1 Remove the burner module as described in Servicing, Section 6.
- 14.2 Remove the fixing screw and slide the plate off the venturi.
- 14.3 Replace with the correct size plate and secure with the screw. Ensure the lower edge of the plate is located over the venturi flange, see Diagram 22.

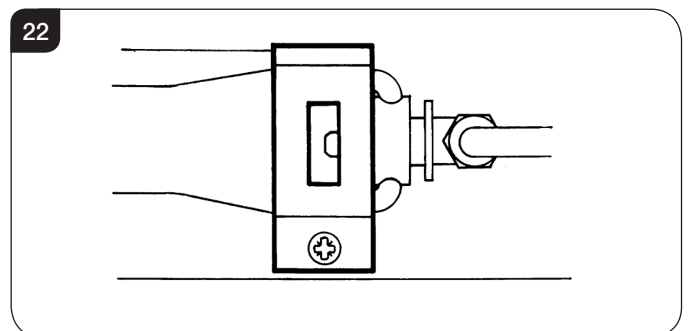

Servicing Instructions - Replacing Parts

15. Changing Between Gas Types

In order to change between gas types it will be necessary to change both the burner assembly and the complete control assembly.

Contact your Gazco retailer for further information.

A kit of parts is available for this. Always quote the Model number and Serial number when ordering any spare parts.

16. Pressure and leak testing the appliance

- 16.1 To gain access to the pressure test point, see Diagram 23 and Section 7, Main Control Assembly.

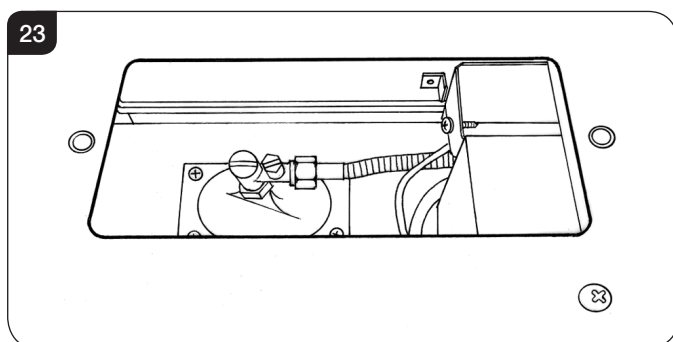

- 16.2 To leak test any gas joints on the appliance the control assembly must be undone and tilted backwards, see Section 7.6, Diagram 15.
- 16.3 Because there is now no burner fitted to perform a leak test, place a manometer tube over the injector tip.
- 16.4 Light the appliance and spray any joints with leak detector fluid.
- 16.5 Tighten joints or replace as required.
- 16.6 To check the inlet working pressure, replace the control assembly and connect a manometer to the pressure test point, see Diagram 23.
- 16.7 Replace the burner and relight the appliance.
- 16.8 Operate the appliance at highest flame setting and check that the inlet pressure is in accordance with specifications detailed on page 12.

Servicing Instructions - Replacing Parts

17. Short Spares List

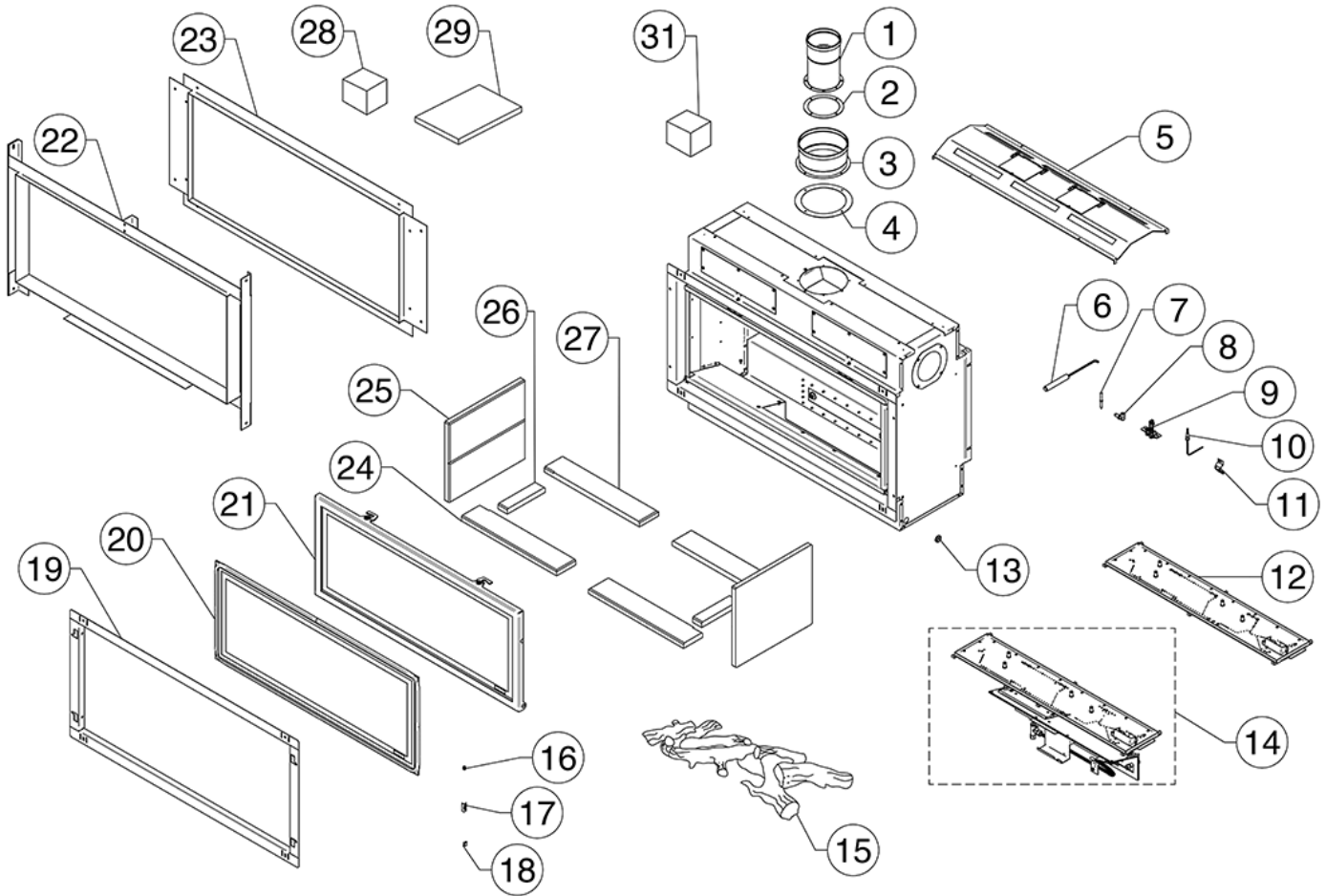

No.	Component	Part Code		Quantity
		Natural Gas	LPG	
1	Inner Spigot	MEC0285		1
2	Inner Flue Gasket	CE0210		1
3	Outer Spigot	MEC0232		1
4	Outer Flue Gasket	CE0211		1
5	Top Baffle Assembly	GZ10592		1
6	Door Tool	GZ6690		1
7	Electrode	PI0075		1
8	Injector	IN0072	IN0073	1
9	Pilot Burner	PI0069	PI0070	1
10	Thermocouple	PI0077		1
11	Aeration Cover	ID Letter E GZ2025		1
12	Burner Assembly	GZ10487	GZ10544	1
13	Grommet	EL0022		2
14	Engine Control Assembly	GZ11905N	GZ11905P	1
15	Log Set	CE1208		1
16	1/4" Tool Clip	FA0522		1
17	Glass Clip Bracket	GZ6361		2
18	Black Steel Edge Clip	FA0523		2

No.	Component	Part Code		Quantity
		Natural Gas	LPG	
19	Installation Frame Assembly	GZ9550		2
20	Glass & Rope Seal Assembly	GZ7353		2
21	Door Assembly	GZ6408		2
22	Cool Wall Installation Kit	8727BFCW02		Kit
23	Edge Installation Kit	8727BF EK02		Kit
24	LH Front & RH Rear Base Lining Vermiculite	CE0689		2
	LH Front & RH Rear Base Lining Black Reed	CE1201		2
25	Side Panel Lining Vermiculite	CE1003		2
	Side Panel Lining Black Reed	CE1203		2
26	Side Piece Lining Vermiculite	CE1206		2
	Side Piece Lining Black Reed	CE1200		2
27	RH Front & LH Rear Base Lining Vermiculite	CE0707		2
	RH Front & LH Rear Base Lining Black Reed	CE1202		2
28	Log Vermiculite	CE0746		1
29	Instruction/ Fixing Kit	GZ11924		Kit
30	N/A	N/A		-
31	Embaglow	GZ8471		1



Due to continual technical improvements please check online or with your Gazco retailer for the most up to date parts lists.

Only use Genuine Gazco spares when servicing your appliance.

All of our essential spare parts and consumable items are available to purchase from our webshop at www.gazcospares.com.

Servicing Instructions - Replacing Parts

17. Short Spares List - Control Assembly

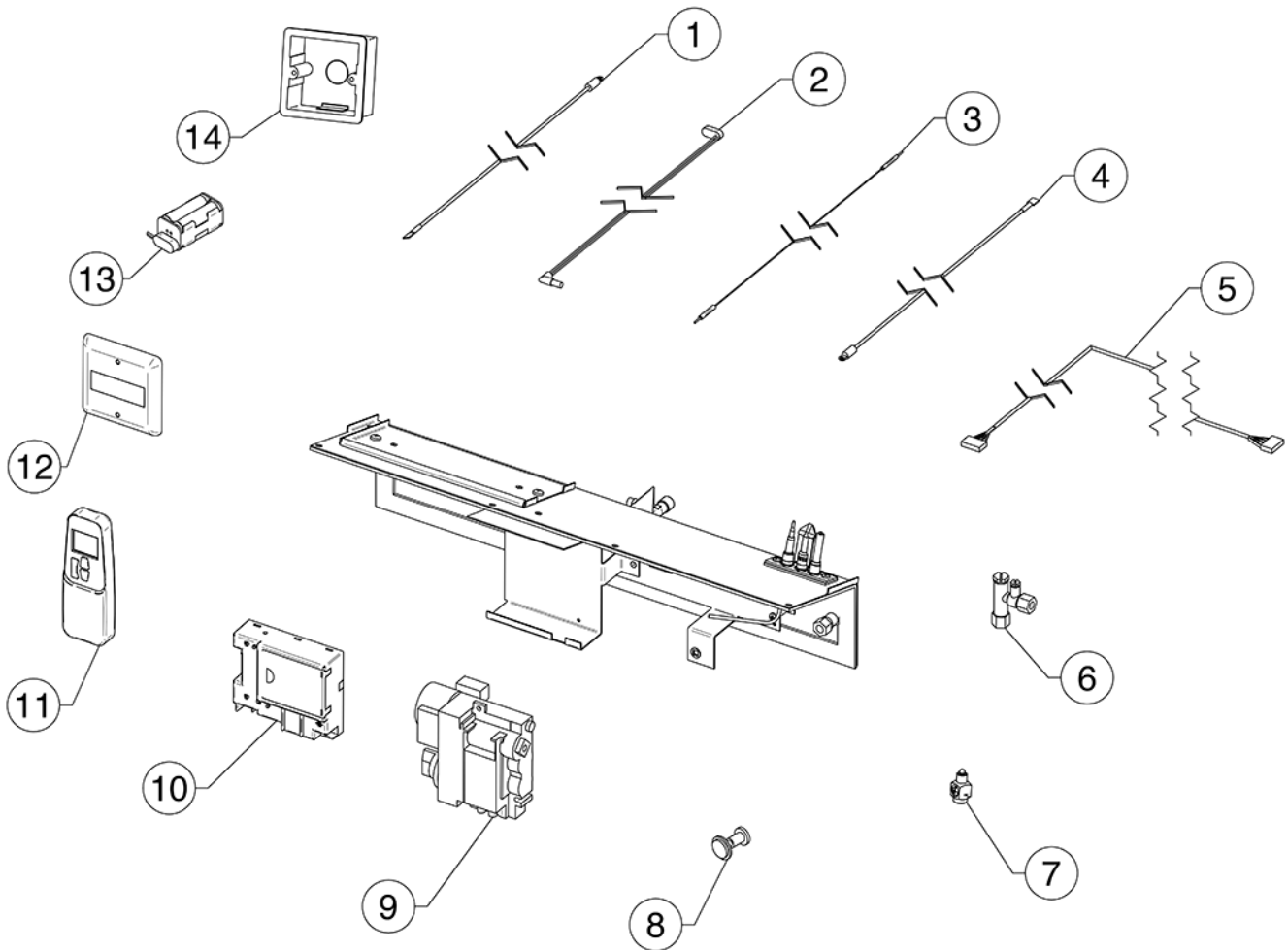

No.	Component	Part Code	Quantity
1	Thermocurrent Cable	EL0590	1
2	3m Cable for Battery	GC0138	1
3	Ignition Cable	GC0125	1
4	Thermocurrent Cable	GC0126	1
5	360mm Connection Cable	GC0133	1
6	Pressure Test Restrictor Elbow	GC0095	1
7	Interrupter	GC0124	1
8	Magnetic Unit	GC0166	1
9	Gas Valve	GC0123K	1
10	Receiver	EL0589	1
11	Handset	EL0571	1
12	Battery Access Cover	EL0591	1
13	Battery Holder	EL0410	1
14	Dry Lining Box	EL0409	1



Due to continual technical improvements please check online or with your Gazco retailer for the most up to date parts lists.

Only use Genuine Gazco spares when servicing your appliance.

All of our essential spare parts and consumable items are available to purchase from our webshop at www.gazcospares.com.

Service Records

1ST SERVICE

Date of Service:.....
Next Service Due:.....
Signed:.....
Retailer's Stamp/GasSafe Registration Number

3RD SERVICE

Date of Service:.....
Next Service Due:.....
Signed:.....
Retailer's Stamp/GasSafe Registration Number

5TH SERVICE

Date of Service:.....
Next Service Due:.....
Signed:.....
Retailer's Stamp/GasSafe Registration Number

7TH SERVICE

Date of Service:.....
Next Service Due:.....
Signed:.....
Retailer's Stamp/GasSafe Registration Number

9TH SERVICE

Date of Service:.....
Next Service Due:.....
Signed:.....
Retailer's Stamp/GasSafe Registration Number

2ND SERVICE

Date of Service:.....
Next Service Due:.....
Signed:.....
Retailer's Stamp/GasSafe Registration Number

4TH SERVICE

Date of Service:.....
Next Service Due:.....
Signed:.....
Retailer's Stamp/GasSafe Registration Number

6TH SERVICE

Date of Service:.....
Next Service Due:.....
Signed:.....
Retailer's Stamp/GasSafe Registration Number

8TH SERVICE

Date of Service:.....
Next Service Due:.....
Signed:.....
Retailer's Stamp/GasSafe Registration Number

10TH SERVICE

Date of Service:.....
Next Service Due:.....
Signed:.....
Retailer's Stamp/GasSafe Registration Number

Information Requirement - Gas Heaters

Information Requirement for Gaseous Fuel Local Space Heater

Model	Studio Duplex NG	Studio Duplex LPG	
Fuel	Space Heating Emissions (NOx) - mg / kWh _{input} (GCV)	130	130
Heat Output	Nominal Heat Output - P_{nom}	7.9kW	7.9kW
	Minimum Heat Output (indicative) - P_{min}	3.0kW	3.3W
Auxiliary Electricity Consumption	At Nominal Heat Output - e_{lmax}	N/A	N/A
	At Minimum Heat Output - e_{lmin}	N/A	N/A
	In Standby Mode - $e_{l_{sb}}$	N/A	N/A
Useful Efficiency (NCV)	Useful Efficiency at nominal heat output - $\eta_{th,nom}$	92%	92%
	Useful Efficiency at minimum heat output (indicative) - $\eta_{th,min}$	82%	82%
Permanent Pilot Flame Power requirement	Permanent Pilot Flame Power requirement (if applicable) - P_{pilot}	N/A	N/A
Type of heat output/room temperature control			
	Electronic room temperature control + day timer	Yes	Yes
Other control options (multiple selections possible)			
	Room temperature control, with presence detection	No	No
	Room temperature control, with open window detection	No	No
	With distance control option	No	No
	With adaptive start control	No	No
	With working time limitation	No	No
	With black bulb sensor	No	No
Energy Efficiency Index	88%	88%	
Energy Efficiency Class	A	A	
Contact:	Gazco Ltd, Osprey Road, Sowton Industrial Estate, Exeter, EX2 7JG		

Gazco Limited, Osprey Road, Sowton Industrial Estate, Exeter, Devon, England EX2 7JG
Technical Customer Services: (01392) 261950 Fax: (01392) 261951
E-mail: technicalservices@gazco.com

A member of the Stovax Group
E & O E